

(19) World Intellectual Property Organization
International Bureau



(43) International Publication Date
14 June 2007 (14.06.2007)

PCT

(10) International Publication Number
WO 2007/066317 A2

(51) International Patent Classification:
A61B 17/322 (2006.01)

(21) International Application Number:
PCT/IL2006/000923

(22) International Filing Date: 10 August 2006 (10.08.2006)

(25) Filing Language: English

(26) Publication Language: English

(71) Applicant (for all designated States except US): HDH
MEDICAL LTD. [IL/IL]; 7 Shlomo Ben Yosef Street,
31254 Haifa (IL).

(72) Inventors; and

(75) Inventors/Applicants (for US only): WAYSBEYN, Igor
[IL/IL]; 107 Aba Hillel Silver Street, Apt. 61, 32696 Haifa
(IL). URIN, Yuri [IL/IL]; 3a/1 Leib Shimoni Street, 32588
Haifa (IL). VAYSBEYN, Irina [IL/IL]; 107 Aba Hillel Sil-
ver Street, Apt. 61, 32696 Haifa (IL).

(74) Agent: PEARL COHEN ZEDEK LATZER; P.O. Box
12704, 46733 Herzelia (IL).

(81) Designated States (unless otherwise indicated, for every
kind of national protection available): AE, AG, AL, AM,
AT, AU, AZ, BA, BB, BG, BR, BW, BY, BZ, CA, CH, CN,
CO, CR, CU, CZ, DE, DK, DM, DZ, EC, EE, EG, ES, FI,

GB, GD, GE, GH, GM, HN, HR, HU, ID, IL, IN, IS, JP,
KE, KG, KM, KN, KP, KR, KZ, LA, LC, LK, LR, LS, LT,
LU, LV, LY, MA, MD, MG, MK, MN, MW, MX, MZ, NA,
NG, NI, NO, NZ, OM, PG, PH, PL, PT, RO, RS, RU, SC,
SD, SE, SG, SK, SL, SM, SY, TJ, TM, TN, TR, TT, TZ,
UA, UG, US, UZ, VC, VN, ZA, ZM, ZW.

(84) Designated States (unless otherwise indicated, for every
kind of regional protection available): ARIPO (BW, GH,
GM, KE, LS, MW, MZ, NA, SD, SL, SZ, TZ, UG, ZM,
ZW), Eurasian (AM, AZ, BY, KG, KZ, MD, RU, TJ, TM),
European (AT, BE, BG, CH, CY, CZ, DE, DK, EE, ES, FI,
FR, GB, GR, HU, IE, IS, IT, LT, LU, LV, MC, NL, PL, PT,
RO, SE, SI, SK, TR), OAPI (BF, BJ, CF, CG, CI, CM, GA,
GN, GQ, GW, ML, MR, NE, SN, TD, TG).

Published:

- upon request of the applicant, before the expiration of the
time limit referred to in Article 21(2)(a)
- without international search report and to be republished
upon receipt of that report
- without classification; title and abstract not checked by the
International Searching Authority
- with an indication in relation to a priority claim considered
not to have been made

For two-letter codes and other abbreviations, refer to the "Guid-
ance Notes on Codes and Abbreviations" appearing at the begin-
ning of each regular issue of the PCT Gazette.

(54) Title: DEVICE AND METHOD FOR PREPARING GRAFT AND FASTENER FOR COUPLING TO VESSEL

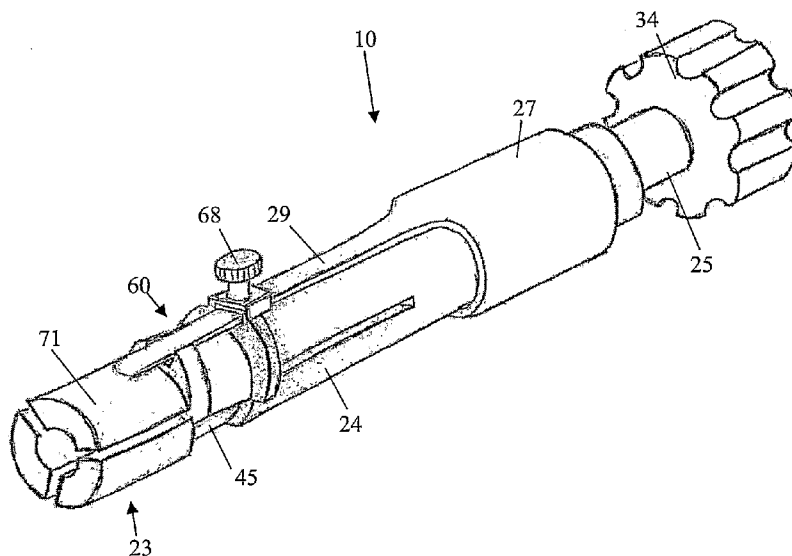

(57) Abstract: The present invention provides device and method for preparation of a graft and a fastener for coupling to a vessel, the device comprising a tubular body with a gripping head at a distal end to grip a graft and a fastener, wherein the graft is threaded through the fastener and wherein an edge of the graft emerges out of the fastener. The gripping head comprises at least three segments arranged around the axis of the head, wherein the segments can be brought closer or pushed away from each other to modify the external diameter of the gripping head and to provide for firm gripping of the fastener and the graft. The device further comprises a pliant tongue which may rotate around the tubular body of the device, wherein radial position of the pliant tongue may be controlled and wherein the pliant tongue may slide axially towards the gripping head or away from the gripping head.

WO 2007/066317 A2

DEVICE AND METHOD FOR PREPARING GRAFT AND FASTENER FOR COUPLING TO VESSEL

BACKGROUND OF THE INVENTION

5 Devices and methods for everting tubular objects inside out are known. In some examples, the material of the object is pierced by hooks that hold the material and enable everting of the material. In these examples the material and the quality of the final outcome may be damaged as a result of the several holes pierced in it. In other examples, an end of a fabric tube is clamped between grips and pulled out to evert the material. In
10 further other examples, tissue in the human body is everted using piercing prongs in a process which may cause damage to the tissue. Some of the known devices and methods are complicated and difficult for use and are not suitable for quick, easy and clean actions as required, for example, in operating rooms. Some of the known devices and methods are not safe and unreliable. Some of the known devices and methods do not
15 enable full everting. US Patent No. 2,156,339 relates to a mechanism for reversing material in tubular form and, more specifically, to attaching means for use in connection therewith. US Patent No. 2,626,090 relates to a device for turning or reversing elongated tubular fabric articles such as belts, or the like. US Patent No. 3,945,542 discloses a device and method for manually everting a cloth or fabric tube where all manipulations
20 may be visually monitored. US Patent No. 4,281,781 discloses a method of everting a knitted sleeve-like portion of wearing apparel, or the like. US Patent Application Publication No. 2003/0032968 discloses a device and method for securing the urethra to the bladder in surgery by means of one or more everting prongs, which risks the intactness of the urethra and bladder. Some of these devices and methods are
25 complicated and difficult for use and are not suitable for quick, easy and clean actions as required, for example, in operating rooms. Some of these devices and methods are not safe enough because damage may be caused to the everted materials.

Devices and methods for coupling grafts to vessels are known. US Patent Application Publication No. 2003/0130671 discloses a method for coupling a first vessel and a
30 second vessel in an anastomosis. US Patent Application Publication No. 2003/0135227 discloses an anastomosis device for use in coupling an end of a graft vessel to a side of a target vessel. US Patent No. 6,740,101 discloses anastomosis systems which include fittings and compression mechanisms for affecting end-end or end-side couplings of

biological or synthetic bypass grafts to vessel locations. Some of these devices and methods are difficult to use and time consuming, especially for small graft diameters. Some of these devices and methods expose foreign material to the blood flow path within the vessels, which increases the risks of hemolysis and thrombosis.

- 5 The known devices and methods are, as described above, based on the simultaneous everting of all the perimeter of an expandable tube end. These devices and methods require especially high elasticity of the material. In each of these methods and devices the everting becomes more difficult and unreliable as the diameter of the tube gets smaller.
- 10 US Patent Application Publication No. 2005/0038502 discloses docking heads to be mounted on a graft so as to establish a vascular device that is coupled to a blood vessel with aneurysm, and dedicated delivery devices as well as methods of coupling. The vascular device comprises a graft having docking head at the proximal portion and another docking head at its distal portion, or two docking heads if the graft is bifurcated.
- 15 The docking heads comprises a hollow truncated cone having a passage adapted to correspond to the outer diameter of the graft and is provided with a plurality of outwardly pointing and inclined barbs. The vascular device is coupled to the blood vessel on both sides of the aneurysm while the docking heads act as guiding, anchoring and sealing means in a suture-less and rapid manner. The vascular device is modular and
- 20 can be prepared according to the condition of the aneurysm and the dimensions of the blood vessels during operation.

SUMMARY OF THE PRESENT INVENTION

- Some embodiments of the present invention may include a device and/or method to
- 25 enable easy and quick preparation of a graft and a fastener such as, for example, the docking heads described in US 2005/0038502, for coupling to a vessel. Preparation of a graft and a fastener by gradually everting an edge of the graft over the fastener provides minimum stretching of the elastic graft, so that no damage to the graft may be caused and no extreme requirements on the elasticity of the graft are needed. Embodiments of
- 30 the present invention may not require or cause piercing of the graft and therefore avoid possible damage to the graft. The easiness and quickness of the preparation of a fastener and graft according to embodiments of the present invention are especially important

when used in operating rooms. The preparation according to embodiments of the present invention remains easy, quick and safe when the diameter of the graft gets smaller.

According to an embodiment of the present invention, a device for preparation of a graft and a fastener for coupling to a vessel may include a tubular body with a gripping head at a distal end to grip a tubular elastic object and a tubular inelastic object, wherein the elastic object may be threadable through the inelastic object, wherein an edge of the elastic object may emerge out of the inelastic object and wherein the external diameter of the head may be modifiable. The head of a device according to embodiment of the present invention may include, for example, at least three segments arranged around the axis of the head, wherein the segments can be brought closer or pushed away from each other to modify the external diameter of the head. A device according to an embodiment of the present invention may further include a pliant tongue which may be rotatable around the tubular body, wherein radial position of the tongue may be controllable, wherein the tongue may be axially slidable towards the grip head or away from the grip head.

A device according to an embodiment of the present invention may further include a collet mandrel which may be insertable to the tubular body, wherein insertion of the collet mandrel into the tubular body may push the segments away from each other thus enlarging the external diameter of the head.

A device according to an embodiment of the present invention may further include a springy cam which may be rotatable around the tubular body to limit at least one of lateral movement and radial movement of the tongue. The springy cam may position the tongue in a prescribed radial position. The springy cam may further include a first shoulder to limit insertion of the inelastic object on the head. The springy cam may further include a second shoulder to indicate proper insertion of the elastic object to enable everting of the edge on the inelastic object. The springy cam may further include a regulator to control radial position of the tongue.

A device according to an embodiment of the present invention may further include a conical section, wherein the tongue may be slidable on the conical section. The conical section may include a shoulder to limit insertion of the inelastic object on the head.

According to an embodiment of the present invention, a method for preparation of a graft and a fastener for coupling to a vessel may include the step of threading a tubular elastic object through a tubular inelastic object, wherein an edge of the elastic object may emerge out of the inelastic object. A method according to an embodiment of the present

invention may further include the steps of inserting the inelastic object together with the threaded elastic object on a grip head a part of the edge being pushed by, for example, the distal edge of a pliant tongue, which is in contact with the tongue, folding the part of the edge over the inelastic object, for example by further sliding the tongue over the
5 inelastic object or sliding the edge over the tongue, and rotating the tongue around the inelastic object to gradually evert the edge over the inelastic object.

A method according to an embodiment of the present invention may further include the step of modifying the external diameter of the grip head to reach firm gripping of the inelastic object and the threaded elastic object.

10 A method according to an embodiment of the present invention may further include the step of sliding the tongue under the edge of the elastic object.

A method according to an embodiment of the present invention may further include the step of regulating the radial position of the tongue.

15 **BRIEF DESCRIPTION OF THE DRAWINGS**

The subject matter regarded as the invention is particularly pointed out and distinctly claimed in the concluding portion of the specification. The invention, however, both as to organization and method of operation, together with objects, features, and advantages thereof, may best be understood by reference to the following detailed description when
20 read with the accompanying drawings in which:

Fig. 1 is a schematic isometric illustration of an everting device according to one embodiment the present invention;

Fig. 2 is a schematic isometric illustration of an everting device according to another embodiment the present invention;

25 Fig. 3 is a schematic isometric illustration of an everting device according to yet another embodiment the present invention;

Fig. 4 is a schematic isometric illustration of an everting device according to yet another embodiment the present invention;

30 Fig. 5 is a schematic cross section illustration of fastener and graft which may be everted on the fastener;

Figs 6A and 6B are partial schematic cross section illustrations of two conditions of a collet mandrel according to one embodiment of the invention;

Fig. 7 is a detailed schematic isometric illustration of a springy cam according to one embodiment of the invention;

Figs. 8A to 8E are partial schematic cross section illustrations of an everting device according to one embodiment of the invention;

5 Figs. 9A and 9B are partial schematic illustrations of an everting device according to one embodiment of the invention.

Figs. 10A to 10C are partial schematic cross-sectional illustrations of everting devices according to embodiments of the invention.

10 Fig.11 is a flowchart describing a method according to one embodiment of the invention.

It will be appreciated that for simplicity and clarity of illustration, elements shown in the figures have not necessarily been drawn to scale. For example, the dimensions of some of the elements may be exaggerated relative to other elements for clarity. Further, where considered appropriate, reference numerals may be repeated among the figures to
15 indicate corresponding or analogous elements.

DETAILED DESCRIPTION OF THE PRESENT INVENTION

In the following detailed description, numerous specific details are set forth in order to provide a thorough understanding of the invention. However, it will be understood by those skilled in the art that the present invention may be practiced without these specific details. In other instances, well-known methods, procedures, and components have not
5 been described in detail so as not to obscure the present invention.

The device and method according to embodiments of the present invention may enable gradual everting of an edge of a tubular elastic graft over a fastener, for example in order to prepare the graft and the fastener for coupling, e.g., in an easy and or quick manner.

10 This may be especially important, for example, when used in operating rooms. The device and method according to embodiments of the present invention may reduce, e.g., minimize stretching of the elastic graft, so that substantially no damage to the graft may be caused, and/or no substantially extreme requirements on the elasticity of the graft may be needed, e.g. even when the diameter of the graft decreases.

15 Reference is made to Fig. 1, which is a schematic illustration of an everting device 11 according to an embodiment of the invention. Everting device 11 may include everter 27, which may include a pliant tongue 29. Everter 27 may rotate around cylindrical member 22. Everter 27 may further slide axially on cylindrical member 22. Everting device 11 may also include a grip head 23. Grip head 23 may include an assembly
20 having several segments 71 arranged around an axis of head 23. Segments 71 may be brought closer or pushed away from each other to modify an external diameter of grip head 23. The external diameter of grip head 23 may be modified when radial pressure is activated on grip head 23. For demonstration only, Fig. 1 shows three segments 71, but the number of segments 71 may vary. More segments 71 will provide more freedom in
25 modifying the outer diameter of grip head 23, and may allow narrower slits between segments 71. Narrower slits may prevent obstructions to the movement of pliant tongue 29 when it rotates around grip head 23. Everting device 11 may also include a conical section 51. Conical section 51 may function, for example, as a limiter to axial movement of a fastener (not shown in Fig.1), as described below. Conical section 51 may facilitate
30 sliding of pliant tongue 29 under a tubular member (not shown in Fig. 1) laid on grip head 23 and extending over conical section 51, as described below. Everting device 11 may further include a flexibility section 24 which may provide flexibility to everting device 11 and may facilitate modifying of the external diameter of everting device 11

and grip head 23. The slits between segments 71 may extend through conical section 51 and flexibility section 24, e.g., to allow further freedom in modifying the external diameter of grip head 23. Everting device 11 may also include a collet mandrel 25. Insertion of collet mandrel 25 into cylindrical member 22 may expand the diameter of flexibility section 24 and grip head 23 as described below. Insertion of collet mandrel 25 into cylindrical member 22 may be performed by, for example, mechanical force, hydraulic force, pneumatic force or a combination thereof. Collet mandrel 25 may include a knob 34 to facilitate rotation and thereby easy insertion and elicitation of collet mandrel 25 into cylindrical member 22, by, for example, a worm (not shown).

Reference is made to Fig. 2, which is a schematic illustration of an everting device 10 according to another embodiment of the invention. Although the invention is not limited in this respect, everting device 10 may have the same functionality as everting device 11 (shown in Figs. 1, 8A-8E and 9A-9C). Everting device 10 may include a grooved section 45 between flexibility section 24 and grip head 23, the slits extending through grooved section 45. Grooved section 45 may be used, for example, to hold means controlling the movement of pliant tongue 29, as described in detail below.

Reference is made to Fig. 3, which is a schematic illustration of everting device 10 according to yet another embodiment of the invention. Springy cam 60 may be inserted on everting device 10. Springy cam 60 may limit lateral and/or radial movement of pliant tongue 29. Springy cam 60 may also position pliant tongue 29 in a desired radial position. Springy cam 60 may be rotatably supported on grooved section 45.

Reference is made to Fig. 4, which is a schematic illustration of everting device 10 according to yet another embodiment of the invention. Springy cam 60 may further include a regulator 68 to limit radial movement outwardly of pliant tongue 29, thus to control radial position of pliant tongue 29, to enable proper folding and everting of a tubular member as described below.

Reference is made to Fig. 5, which is a schematic cross section illustration of a fastener 12 and a graft 13 which may be everted on fastener 12 using the device and method according to embodiments of the present invention.. Fastener 12 may have a conical portion 12a and a cylindrical portion 12b. Inner diameters of cylindrical portion 12b and of conical portion 12a may coincide. Graft 13 may be inserted through conical portion 12a and cylindrical portion 12b, e.g. such that some portion of graft 13 may emerge out of cylindrical portion 12b, so as to be foldable over cylindrical portion 12b. Conical portion 12a may be provided with a plurality of inclined barbs, as shown in Figs. 9A and

9B. After fastener 12 and graft 13 are coupled using the device and method according to embodiments of the present invention, e.g., as described below, fastener 12 may be anchored to a blood vessel without sutures and/or in a quick manner. Fastener 12 may be formed of, for example, polymers, metals, special types of glass and other biocompatible materials. Graft 13 may be, for example, an artificial vascular graft or a natural graft made of a biological tissue.

Reference is made to Figs. 6A and 6B, which are partial schematic cross section illustrations of two conditions of collet mandrel 25 in everting device 10, according to one embodiment of the invention. Collet mandrel 25 may have a conical end 31. Collet mandrel 25 may be inserted into a cavity 21. When inserting collet mandrel 25 into cavity 21, conical end 31 may be pushed between internal supports 96 of segments 71 (Fig. 4), thus pushing internal supports 96 away from each other and expanding the external diameter of grip head 23. When the diameter of grip head 23 has expanded to reach firm gripping of fastener 12 and graft 13, insertion of collet mandrel 25 may be stopped and the axial movement of collet mandrel 25 may be locked, e.g. due to the mechanical arrangement of the worm of collet mandrel 25 or any other suitable locking arrangement (not shown). The portion of graft 13 that emerges out of cylindrical portion 12b may then be stretched out, and pliant tongue 29 may be positioned in a required radial position to enable pliant tongue 29 to slide on cylindrical portion 12b, as seen in Fig 6A. Springy cam 60 may be rotatably supported on grooved section 45 and may support pliant tongue 29, as described above. Pliant tongue 29 may slide axially towards fastener 12. A part of graft 13 which is in contact with pliant tongue 29 may be pushed up by pliant tongue 29 and may be folded over cylindrical portion 12b, as seen in Fig. 6B. Pliant tongue 29 may then be rotated to encircle cylindrical portion 12b. By rotation of pliant tongue 29, the portion of graft 13 that emerges out of cylindrical portion 12b may be gradually everted over cylindrical portion 12b. When the eversion is completed, pliant tongue 29 may slide away from fastener 12. Collet mandrel 25 may then be pulled away from internal supports 96, e.g. by turning knob 34 backwards, thus enabling the external diameter of grip head 23 to be reduced. When the external diameter of grip head 23 is reduced, the gripping of fastener 12 and graft 13 on grip head 23 may be released, and fastener 12 together with graft 13 may be removed from grip head 23.

Reference is made to Fig. 7, which is a detailed schematic illustration of springy cam 50 according to one embodiment of the invention. Although the invention is not limited in this respect, springy cam 50 may have the same functionality as springy cam 60 (shown

in Figs. 3, 4, 6A-6B and 10A-10C). Springy cam 50 may include a first shoulder 62. First shoulder 62 may include a socket 63 to laterally support pliant tongue 29 (Figs. 6A and 6B). First shoulder 62 may position pliant tongue 29 in a prescribed radial position. First shoulder 62 may provide barrier to limit insertion of fastener 12 (Figs. 6A and 6B) onto grip head 23 (Figs. 6A and 6B). According to some embodiments springy cam 50 may include a second shoulder 61. Second shoulder 61 may include a passage 64 to support pliant tongue 29 radially and/or axially. Passage 66 may further include a regulator 68 to limit radial position of pliant tongue 29 to enable proper folding and everting of an edge of graft 13 over cylindrical portion 12b. Second shoulder 61 may indicate proper length of the portion of graft 13 (Figs. 6A and 6B) inserted onto grip head 23 (Figs. 6A and 6B). The size of springy cam 50 may be chosen to match a diameter of a specific fastener 12. Springy cam 50 may include an arch 67. Arch 67 may be elastic. An internal diameter of arch 67 may be slightly smaller than an outer diameter of grooved section 45 (not shown). Springy cam 50 may be installed on grooved section 45 by pushing arch 67, e.g. forcefully, onto grooved section 45. A portion of the perimeter of grooved section 45 may be unoccupied by arch 67, thus preventing overstretching of graft 13.

Reference is made to Figs. 8A-8E, which are partial schematic cross section illustration of everting device 11 illustrating different stages of everting graft 13 onto fastener 12 according to an embodiment of the invention. Figs. 9A and 9B are additional partial schematic illustrations of these stages. Graft 13 may be inserted on everting device 11 so that the end of graft 13 may rest upon a shoulder of conical section 51. Fastener 12 may be inserted on graft 13 until the outer edge of cylindrical portion 12b meets the shoulder of conical section 51. In the embodiment illustrated in Figs. 6A and 6B graft 13 may be inserted on everting device 11 until the end of graft 13 meets second shoulder 61 and fastener 12 may be inserted until the edge of cylindrical portion 12b meets first shoulder 62. The diameter of grip head 23 may then be adjusted to firmly hold fastener 12 and graft 13 together, for example by inserting collet mandrel 25 into cylindrical member 22, as described above with reference to Figs 6A and 6B. When inserting fastener 12 with graft 13 on device 11, pliant tongue 29 may slide on conical section 51 under the portion of graft 13 that emerges out of cylindrical portion 12b (Fig. 8A). The part of graft 13 that is in contact with pliant tongue 29 may be pushed up and inversely by pliant tongue 29 (Fig. 8B) and may be folded over the edge of fastener 12 by further sliding pliant tongue 29 axially over cylindrical portion 12b and turning pliant tongue 29 in a rotary motion

(Fig. 8C). Pliant tongue 29 may then be further rotated to encircle cylindrical portion 12b. By rotation of pliant tongue 29, the portion of graft 13 that emerges out of cylindrical portion 12b may be gradually folded and everted over the edge of fastener 12 (Figs. 8D and 8E). When pliant tongue 29 completes a substantially full circle around cylindrical portion 12b, the portion of graft 13 that emerges out of fastener 12 may be fully everted (Fig. 8E).

Reference is now made to Figs. 10A to 10C, which are partial schematic cross-sectional illustrations of everting devices 101, 102, 103 according to some embodiments of the invention. Although the invention is not limited in this respect, everting devices 101, 102, 103 may have the same functionality as everting device 10 (shown in Figs. 2-4 and 6A-6B) and/or everting device 11 (shown in Figs. 1, 8A-8E and 9A-9C). Devices according to embodiments of the present invention may vary in shape and/or size to fit to different diameters or diameter ranges of graft 13 and/or fastener 12. The shape and size of head 23 may vary in different embodiments of devices of the present invention to match different shapes and/or sizes of graft 13 and/or fastener 12. The shape and/or size of pliant tongue 29 may vary in different embodiments of devices of the present invention to match different shapes and/or sizes of graft 13 and/or fastener 12. Figs. 10A to 10C show, for example, different shapes and different relative sizes of head 23, pliant tongue 29, collet mandrel 25, conical end 31 and springy cam 60, so as to fit different diameters and/or ranges of diameters of graft 13 and/or fastener 12, e.g. while maintaining the functionalities of gripping of fastener 12 with graft 13, everting of the end of graft 13 and releasing fastener 12 with everted graft 13 substantially, as described above.

Reference is made to Fig. 11, which is a flowchart describing a method for everting an edge of graft 13 over the edge of fastener 12 according to one embodiment of the invention. As indicated in block 110, the method may include threading graft 13 through fastener 12. As indicated in block 112, the method may include inserting graft 13 and fastener 12 on grip head 23. As indicated in block 114, the method may include modifying the external diameter of grip head 23 thereby reaching firm gripping of fastener 12 and graft 13. As indicated in block 116, the method may include regulating the radial position of pliant tongue 29, for example by regulator 68. As indicated in block 118, the method may include sliding pliant tongue 29 under the portion of graft 13 that emerges out of cylindrical portion 12b. As indicated in block 120, the method may include pushing, for example by pliant tongue 29, the part of graft 13 that is in contact with

pliant tongue 29. As indicated in block 122, the method may include The method of Fig. 11 may further include folding the part of graft 13 that is in contact with pliant tongue 29 over cylindrical portion 12b, for example by further sliding pliant tongue 29 over cylindrical portion 12b. As indicated in block 124, the method may include rotating
5 pliant tongue 29 around cylindrical portion 12b thereby gradually everting the portion of graft 13 that emerges out of cylindrical portion 12b.

While certain features of the invention have been illustrated and described herein, many modifications, substitutions, changes, and equivalents will now occur to those of ordinary skill in the art. It is, therefore, to be understood that the appended claims are
10 intended to cover all such modifications and changes as fall within the true spirit of the invention.

CLAIMS

What is claimed is:

1. An everting device comprising:
a tubular body comprising a grip head at a distal end wherein an external diameter of said head is modifiable; and
a pliant tongue rotatable around said tubular body and springy with respect to the axis of said tubular body, wherein radial position of said tongue is adjustable, wherein said tongue is axially slidable towards said grip head or away from said grip head.
2. A device according to claim 1, wherein said grip head to grip a tubular elastic object and a tubular inelastic object, wherein an edge of said elastic object is emergable out of said inelastic object.
3. A device according to claim 1, wherein said grip head comprises at least three segments, said segments can be brought closer or pushed away from each other to modify the external diameter of said grip head.
4. A device according to claim 3, further comprising a collet mandrel insertable into said tubular body to push away said segments thus to enlarge the external diameter of said grip head.
5. A device according to claim 1, further comprising a springy cam rotatable around said tubular body to limit at least one of lateral movement and radial movement of said tongue.
6. A device according to claim 5, wherein said springy cam is adapted to firmly position said tongue in a prescribed radial position.
7. A device according to claims 2 and 5, wherein said springy cam further comprising a first shoulder to limit insertion of said inelastic object on said grip head.
8. A device according to claims 2 and 7, wherein said springy cam further comprises a second shoulder to indicate proper insertion of said elastic object.

9. A device according to claim 5, wherein said springy cam further comprising a regulator to control radial position of said tongue.
10. A device according to claim 1, further comprising a conical section, wherein said tongue is slidable on said conical section.
11. A device according to claims 2 and 10, wherein said conical section further comprising a shoulder to limit insertion of said inelastic object on said grip head.
12. A device according to claim 2, wherein said elastic object is a vessel graft.
13. A device according to claim 12, wherein said inelastic object is a fastener adapted to couple said graft to a vessel.
14. A method comprising the steps of:
threading a tubular elastic object through a tubular inelastic object until a leading edge of said elastic object emerges out of said inelastic object substantially longer than the length of said inelastic object;
gripping said inelastic object together with said threaded elastic object by a grip head installed at a first end of an everting device;
pushing by a pliant tongue part of said edge which is in contact with said tongue;
folding said part of said edge over an edge of said inelastic object by further sliding said tongue over said inelastic object together with said edge of said elastic object;
gradually everting said edge over said inelastic object by rotating said tongue around said inelastic object and sliding said pliant tongue axially toward said grip head.
15. A method according to claim 14, further comprising the step of pushing said tubular inelastic object with said tubular elastic object onto said grip head until the leading edge of said tubular inelastic object reaches a stopping means.

16. A method according to claim 14, wherein said gripping comprising the steps of inserting said inelastic object together with said threaded elastic object onto a grip head and modifying the external diameter of said grip head to reach firm gripping of said inelastic object and said threaded elastic object.
17. A method according to claim 14, further comprising, before the step of pushing, a step of sliding said tongue under said edge of said elastic object.
18. A method according to claim 14, further comprising a step of regulating the radial position of said tongue.
19. A method according to claim 14, further comprising at least one of the steps comprising sliding said pliant tongue away from said inelastic object, reducing external diameter of said grip head and removing said elastic object and said inelastic object from said grip head.

1/11

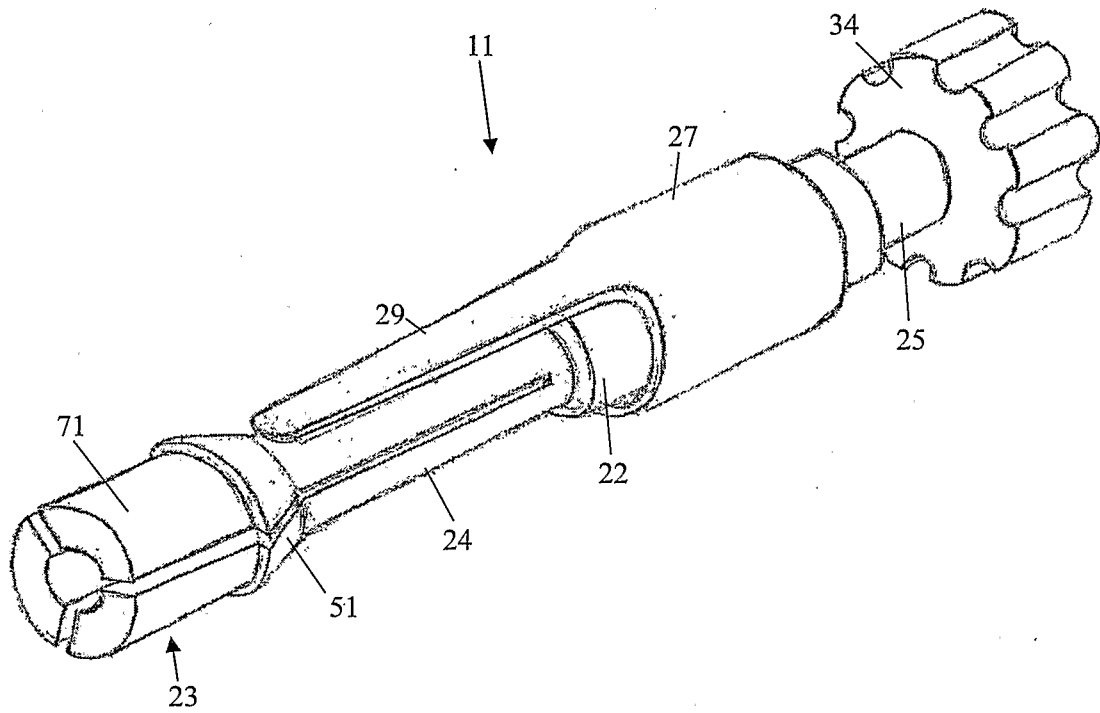

Fig. 1

2/11

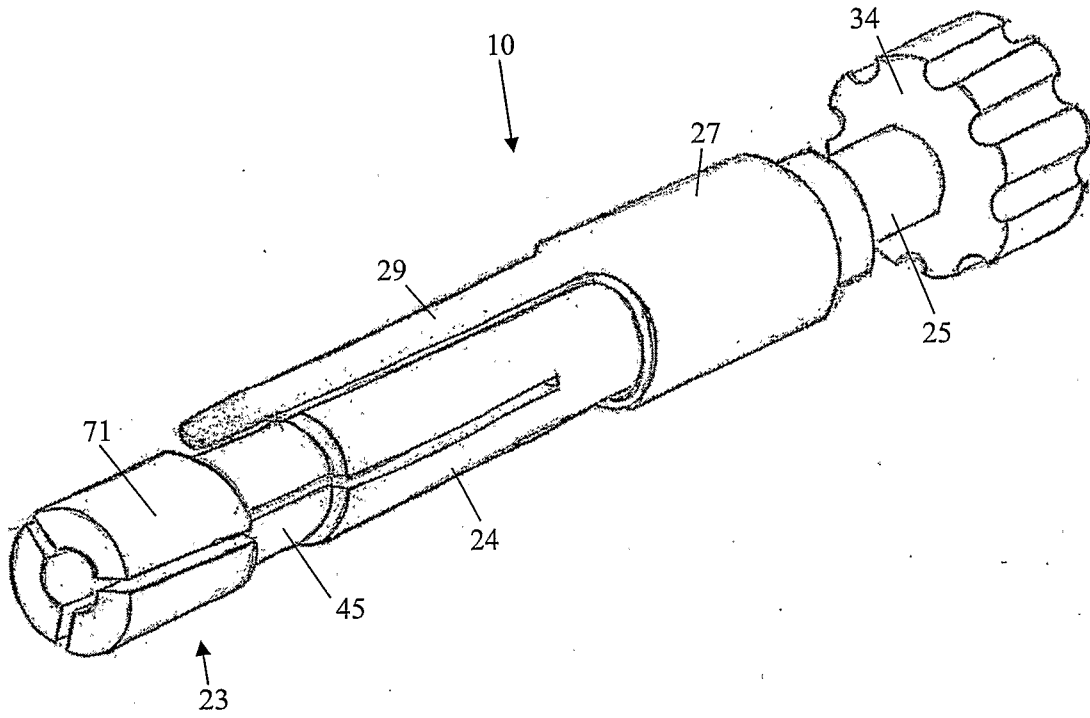

Fig. 2

3/11

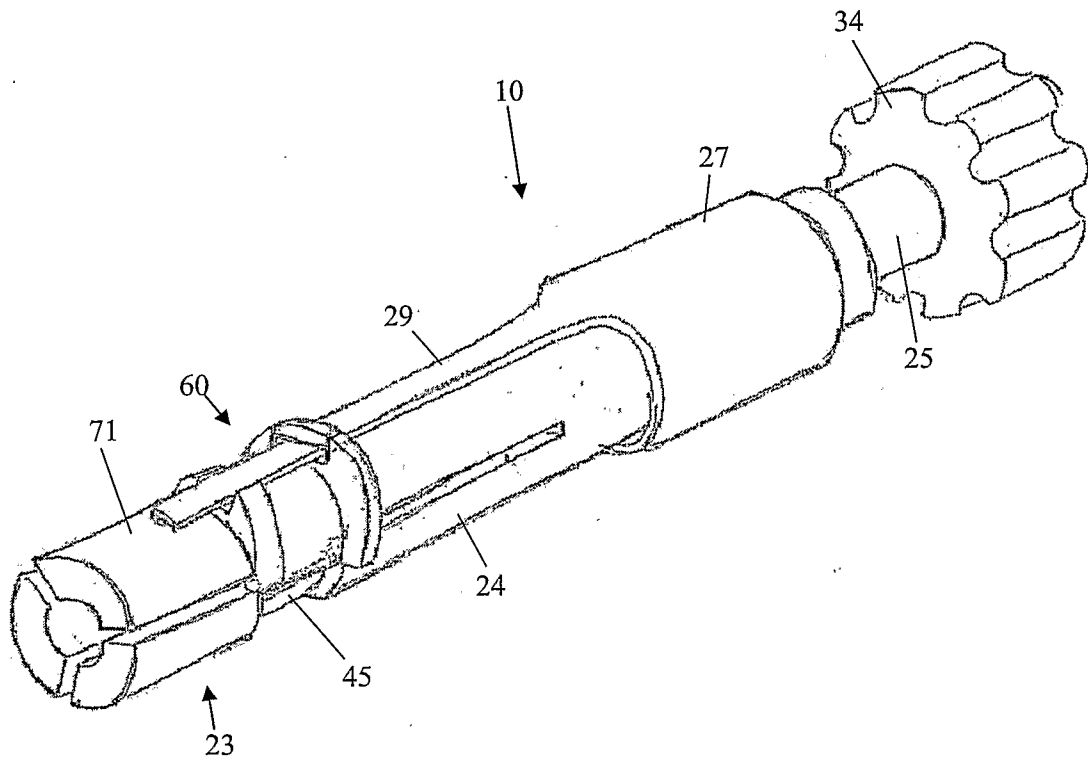

Fig. 3

4/11

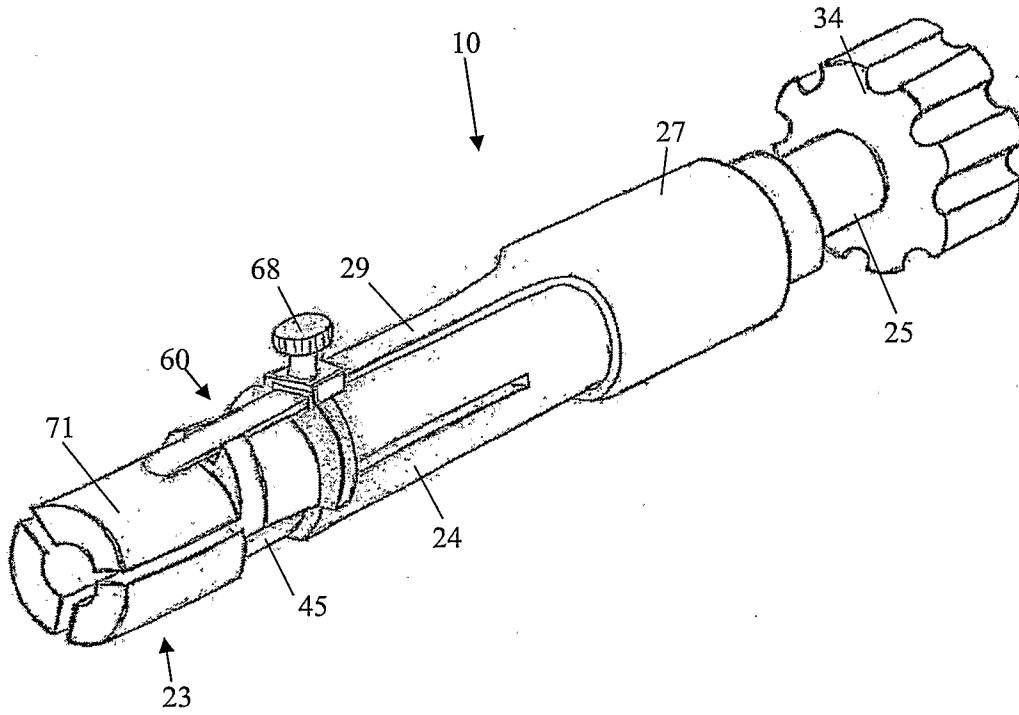

Fig. 4

5/11

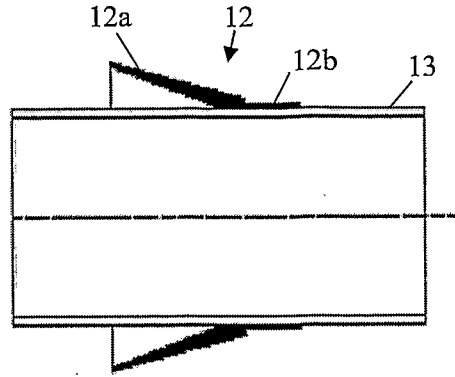

Fig. 5

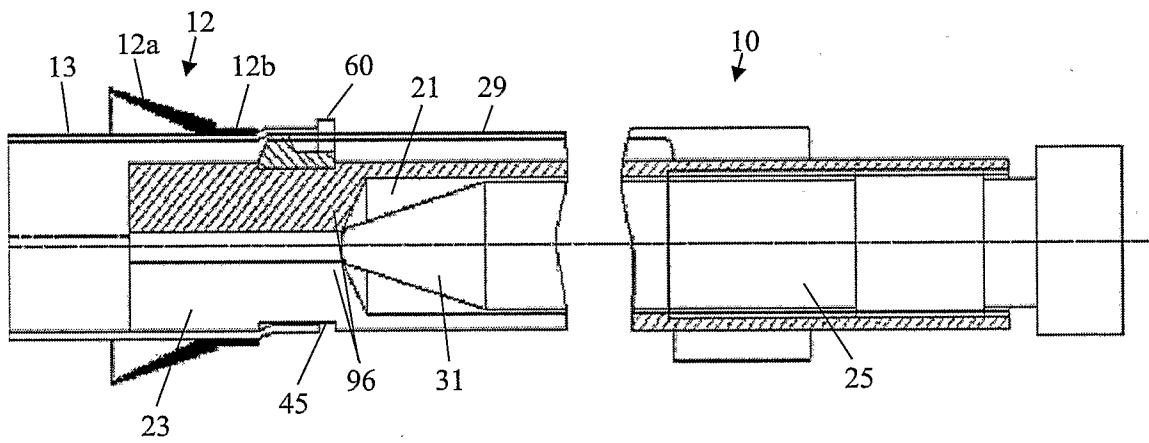

Fig. 6A

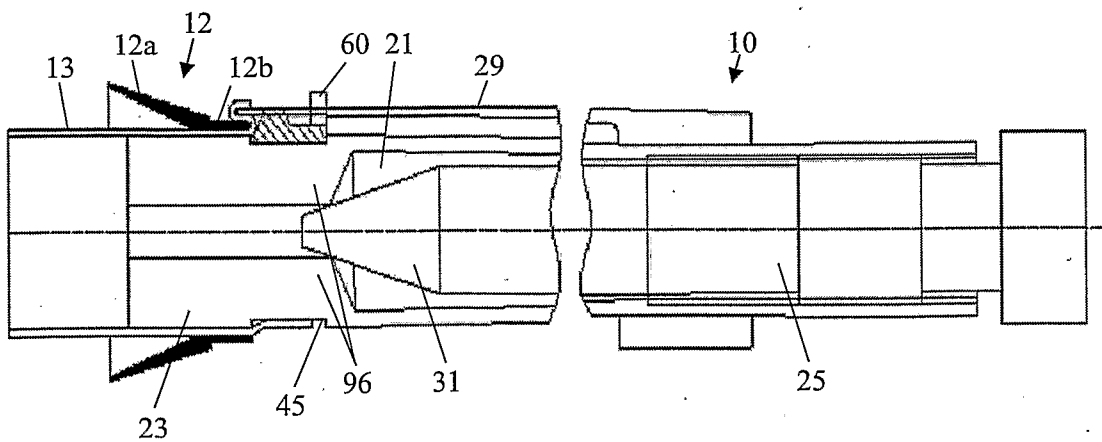

Fig. 6B

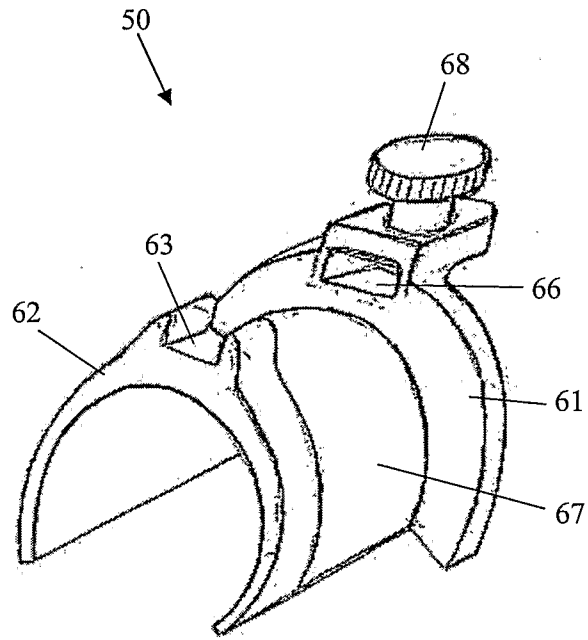

Fig. 7

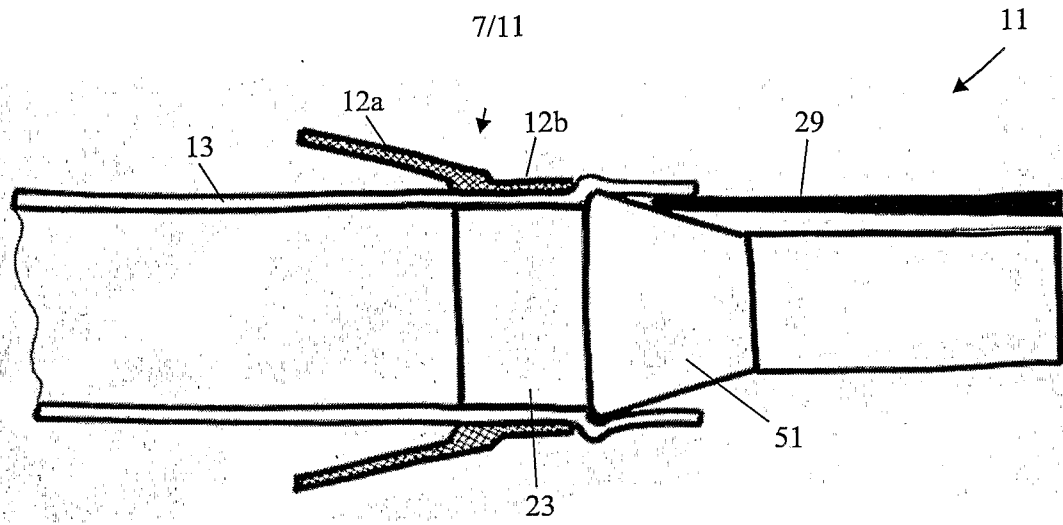

Fig. 8A

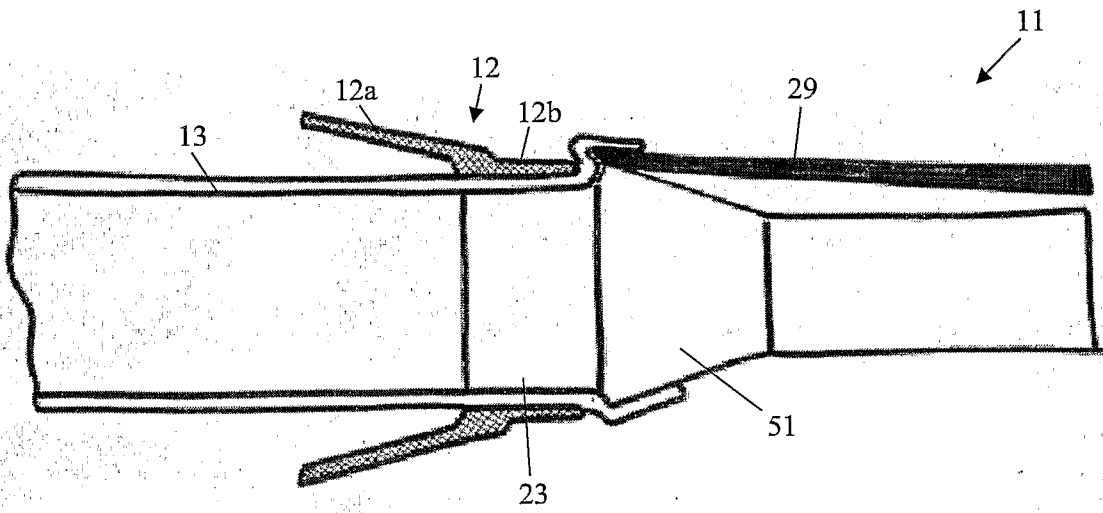

Fig. 8B

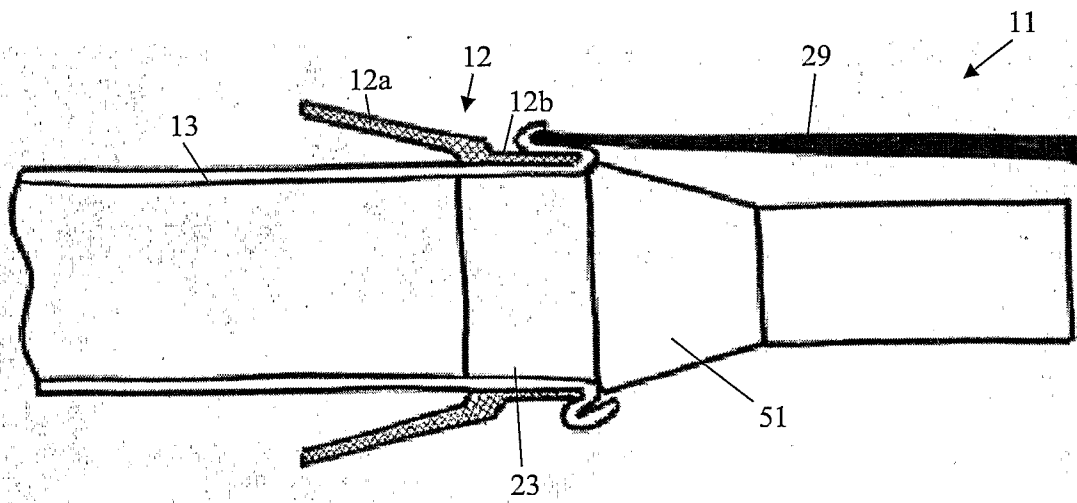

Fig. 8C

8/11

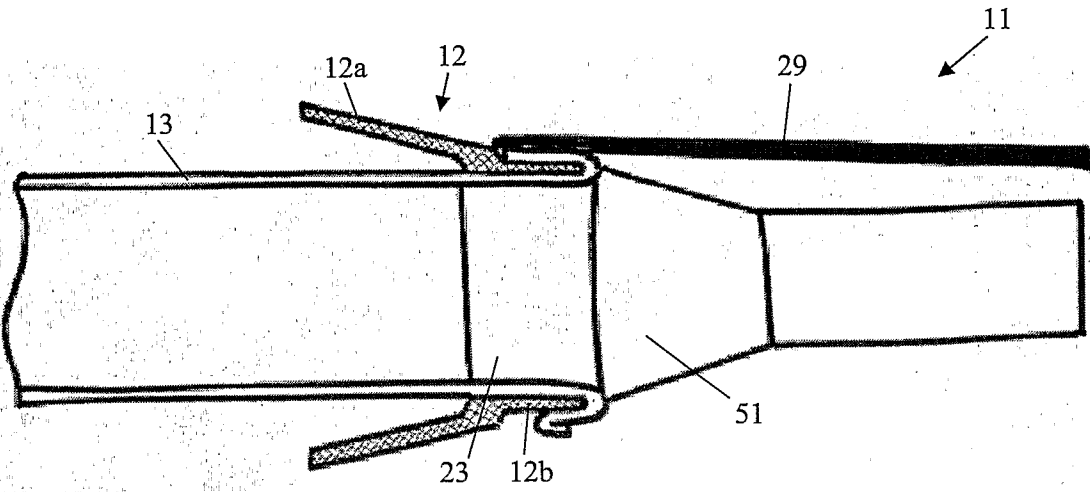

Fig. 8D

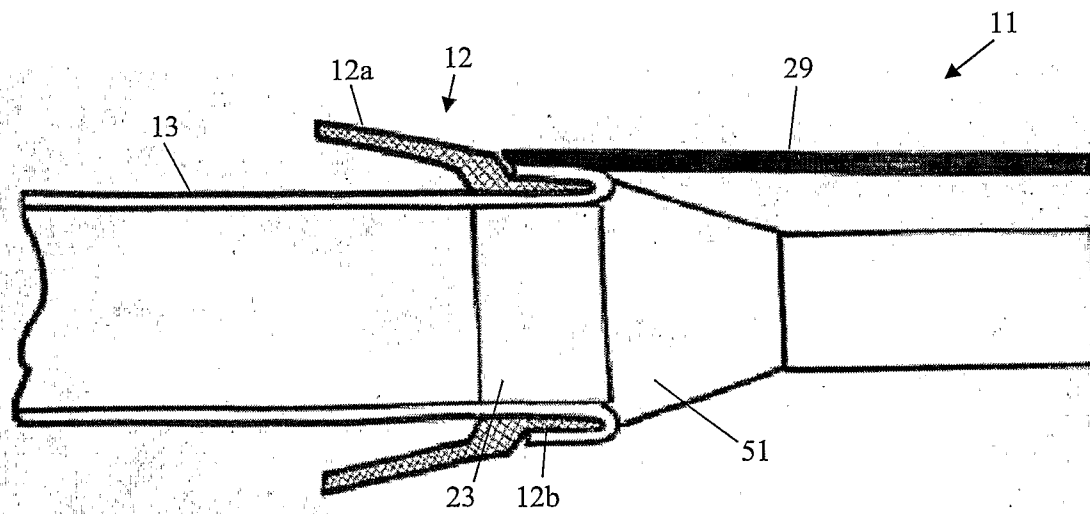

Fig. 8E

9/11

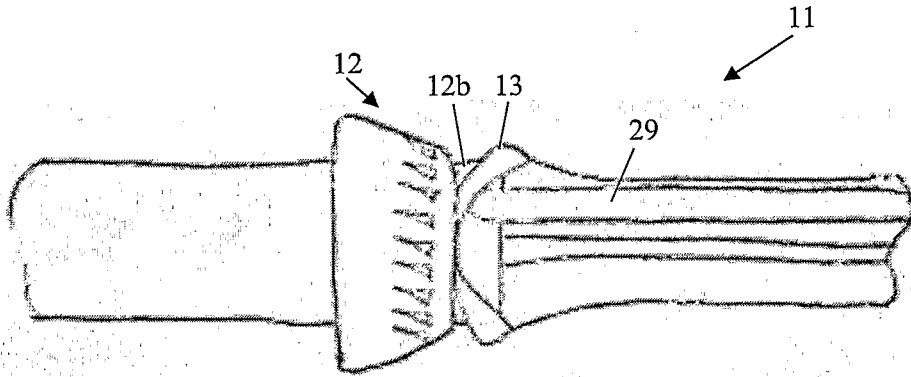

Fig. 9A

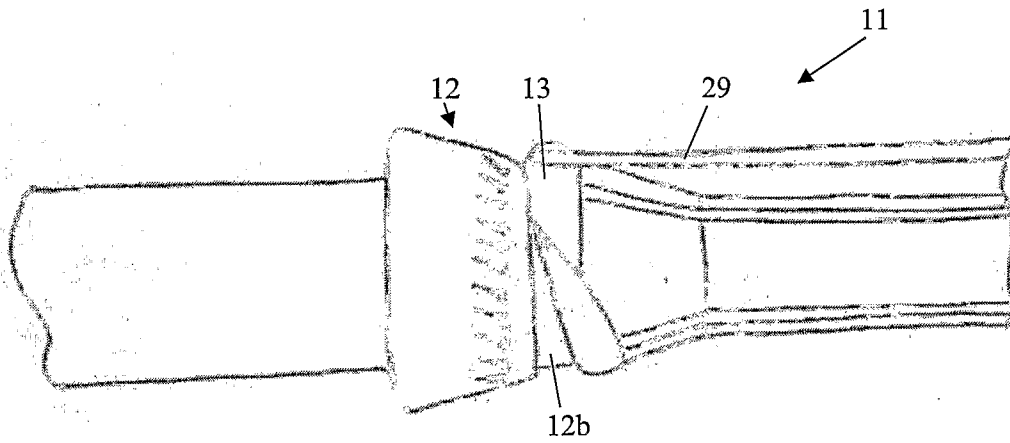

Fig. 9B

10/11

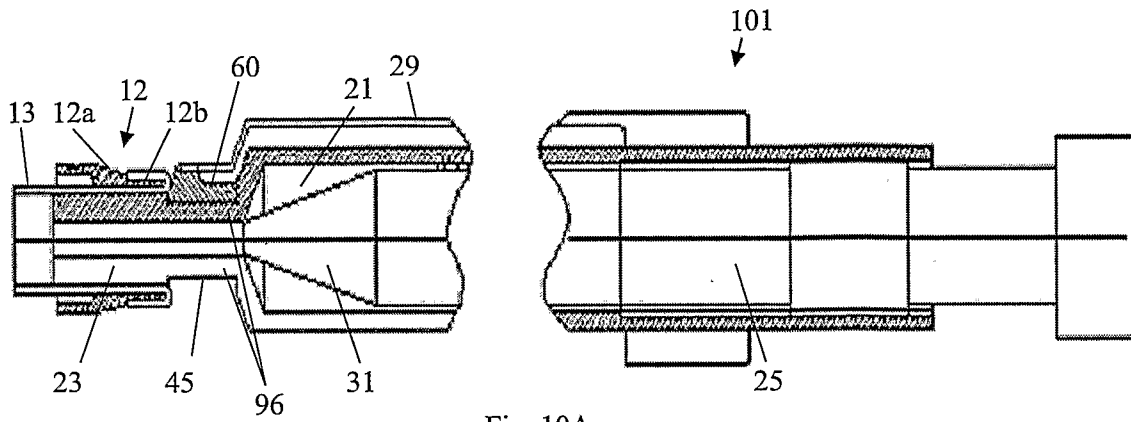

Fig. 10A

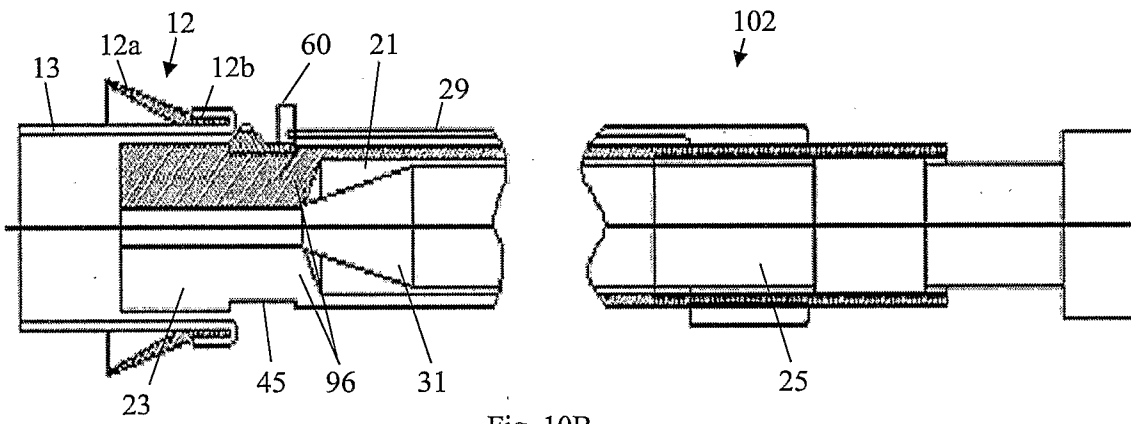

Fig. 10B

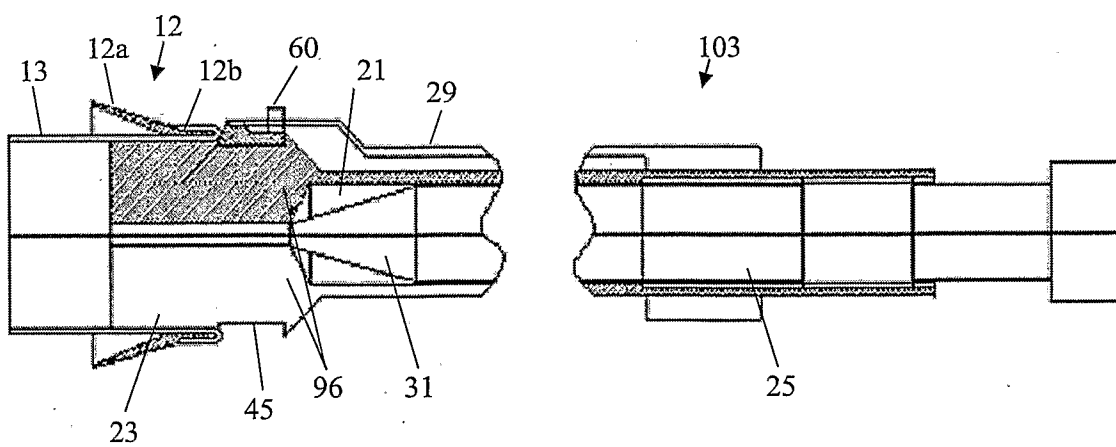

Fig. 10C

11/11

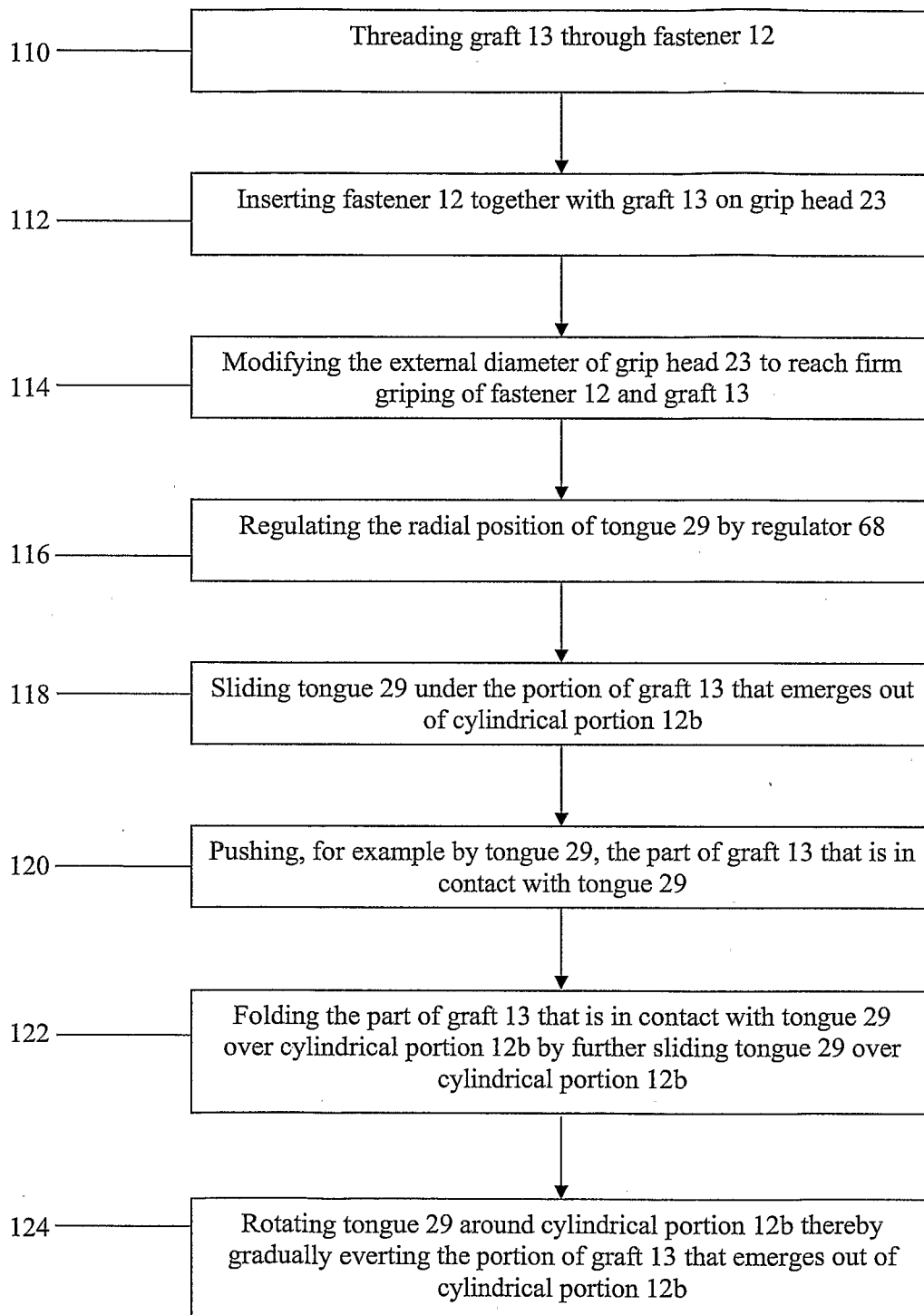

Fig. 11

APPLICANTS: HDH MEDICAL LTD, et al.
INTERNATIONAL APPLICATION NO.: PCT/IL2006/000923
INTERNATIONAL FILING DATE: 10 August 2006
TITLE: DEVICE AND METHOD FOR PREPARING GRAFT AND FASTENER FOR COUPLING TO VESSEL

2 Pages via Facsimile
Confirmation copy via mail
Facsimile Number: +41 22 338 71 30 / +41 22 338 82 70

ATTN: Suarez Javier
The International Bureau of WIPO
34, Chemin des Colombettes
1211 Geneva 20
Switzerland

Dear Sirs:

In accordance with Article 21(2)(b), and Rules 48.2 (g) and (h), and 48.4, we hereby request the early publication of the above referenced International Application, as soon as possible, so that publication occurs as close to the 18-month publication deadline of February 4, 2007 (as calculated from the purported priority date).

Additionally, in accordance with PCT Rule 26bis2(c), we hereby request publication of information concerning the priority claim considered not to have been made. The respective fee of 250 Swiss Francs, the total amount for both requests, was paid by bank transfer to WIPO on February 19, 2007.

Kindly send us a notification when the International Application has been published so that we may download a copy for our records.

Respectfully submitted,

Yosi Barkai
Agent for Applicants

Date: 20 February 2007

Pearl Cohen Zedek Latzer
Shenkar 5
PO Box 12704
Herzlia 46733
Israel
Tel: +972 9 972 8000
Fax: +972 9 972 8001

Cc:
Israel Patent Office (Attention: Irena Grabe) - Via Fax: - 02-565-1616
PCT Division
4 Hasadna Street
Talpiot Industrial Area
Champion Motors Building
Jerusalem 93420
Israel