

June 11, 1940.

P. H. TRAVIS

2,204,331

DOOR CHECK

Original Filed Sept. 15, 1939

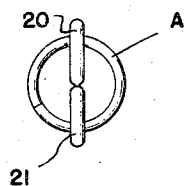
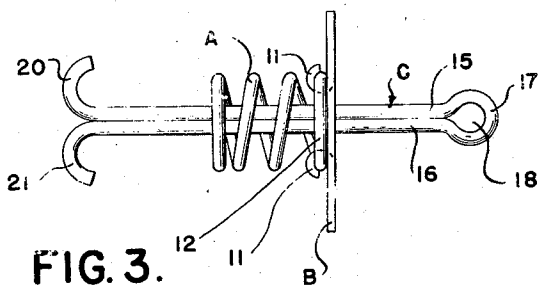
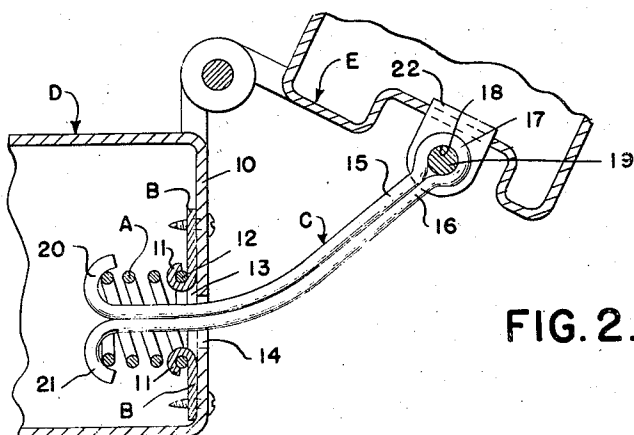
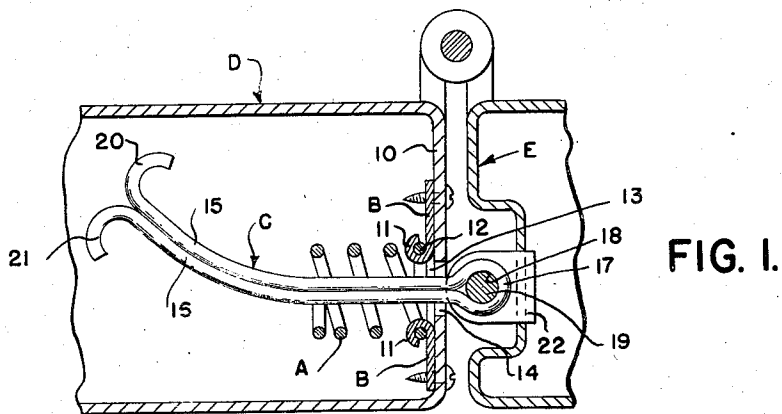

INVENTOR.

PAUL H. TRAVIS

BY *William H. Fuller & Silkeup*
ATTORNEYS

UNITED STATES PATENT OFFICE

2,204,331

DOOR CHECK

Paul H. Travis, Detroit, Mich.

Original application September 15, 1939, Serial
No. 295,136. Divided and this application
February 5, 1940, Serial No. 317,406

6 Claims. (Cl. 16-85)

This invention relates generally to door checks and constitutes a division of my application filed September 15, 1939, bearing Serial No. 295,136, which has become Patent No. 2,193,990, dated March 19, 1940.

One of the essential objects of the invention is to provide a device of this kind wherein provision is made for effectively absorbing or cushioning shocks resulting from checking the outward swinging movements of a door.

Another object is to provide a structure wherein the shank is separate from and movable freely relative to the cushioning element which preferably is anchored to the hinge pillar for the door.

Another object is to provide a strong and durable device that is simple in construction, economical to manufacture, and easy to install.

Other objects, advantages and novel details of construction of this invention will be made more apparent as this description proceeds, especially when considered in connection with the accompanying drawing, wherein:

Figure 1 is a fragmentary horizontal sectional view through a swinging door, supporting hinge pillar therefor, and door check embodying my invention, and showing the arrangement of parts when the door is in closed position;

Figure 2 is a view similar to Figure 1, but showing the door in open position;

Figure 3 is a detail side elevation of the door check structure;

Figure 4 is an end view of the door check structure illustrated in Figure 3, with the attaching plate removed.

Referring now to the drawing, A is the cushioning element, B is the attaching plate therefor, and C is the shank of a door check structure embodying my invention.

As shown, the cushioning element A is a coil of spring wire separate from and substantially concentric with the shank C. One end of this cushioning element A is fixed to the attaching plate B, while the other end is free. In the present instance the attaching plate B is secured to a wall 10 of the pillar D and has curled portions 11 embracing the wire of the adjacent convolution 12 of the cushioning element.

The shank C extends through the cushioning element A and through aligned openings 13 and 14, respectively, in the attaching plate B and wall 10 of the pillar. Preferably this shank comprises elongated return-bent portions 15 and 16, respectively, of spring wire. Actually the wire is return-bent upon itself in such a way

that the elongated portions 15 and 16 contact each other throughout substantially their entire length. The return-bend 17 of the wire at one end of the shank is preferably opened slightly to provide an eye 18 for the reception of a suitable anchorage member such as 19. The end portions 20 and 21, respectively, of the wire at the other end of the shank are preferably C-shaped and extend laterally relative to the shank for engagement with the free end of the cushioning element A.

In use, the door check extends substantially horizontally between the door E and its supporting hinge pillar D. Preferably the anchorage member 19 is in the form of a pin and is carried by two spaced angle plates 22 fixed to the door E. The hinge pillar D is hollow and forms a housing for the attaching plate B, cushioning element A and C-shaped end portions 20 and 21 of the wire forming the shank. When the door E is opened, the C-shaped portions 20 and 21 of the wire forming the shank will abut the free end of the coil A constituting the cushioning element and will not only check the opening movement of the door but will cushion and absorb any shocks resulting from the checking action. The cushioning element A is, of course, compressible longitudinally of the shank C and is limited in such movement by the attaching plate B.

Thus, from the foregoing, it will be apparent that the door check shown and described herein is simple yet strong and durable in construction and can be manufactured at a comparatively low cost. It will also be apparent that the structure shown includes means for effectively cushioning or absorbing shocks resulting from checking the swinging movement of the door to which it is applied.

What I claim as my invention is:

1. A door check having a shank and a cushioning element, the shank being formed from a single strand of wire return-bent upon itself, the return-bend of the wire being enlarged to form an eye, the free ends of the wire being bent laterally into substantially C-configuration, and the cushioning element being formed from another strand of wire and being sleeved in substantially concentric relation upon the shank between the eye and C-shaped end portions aforesaid.

2. A door check having a shank and a cushioning element, the shank being elongated in configuration and formed from a single strand of wire, the cushioning element being a coil formed from another strand of wire and en-

circling the shank intermediate its ends, said coil being anchored at one end, and the shank being movable freely lengthwise of the coil and having a laterally extending portion engageable with the free end of the coil.

5 3. A door check having an attaching plate, a shank, and a cushioning element, the shank extending through the attaching plate and being formed from a single strand of wire return-bent upon itself, the return-bend of the wire being enlarged to form an eye for an anchorage member, the free ends of the wire being bent laterally into substantially C-configuration, and the cushioning element being formed from another strand of wire and being sleeved in substantially concentric relation upon the shank between the attaching plate and C-shaped end portions aforesaid.

10 4. A door check having an attaching plate, a shank, and a cushioning element, the shank extending freely through the attaching plate and being formed from a single strand of wire, said shank being provided at one end with an eye for an anchorage member and provided at its other end with a laterally extending portion, said shank being movable longitudinally through the attaching plate, the cushioning element being a coil formed from another strand of wire and being sleeved in substantially concentric relation upon the shank between the attaching plate and laterally extending portion aforesaid, one end of said coil being fixed to the attaching plate, the other end of said coil being free in the path of and serving as a yieldable buffer for the laterally extending portion of the shank.

5. A door check having an attaching plate, a shank and a cushioning element, the attaching plate having an opening therein, the shank extending freely through the opening in the attaching plate and being formed from a single strand of wire return-bent upon itself, the return-bend of the wire being upon one side of the attaching plate and enlarged to form an eye for an anchorage pin, the free ends of the return-bent wire being upon the other side of the attaching plate and bent laterally into substantially C-configuration, said shank being movable longitudinally through the opening in the attaching plate, the cushioning element being a coil of wire sleeved in substantially concentric relation upon the shank between the attaching plate and C-shaped end portions of the shank, one end of the coil being fixed to the attaching plate, the other end of said coil being free in the path of and serving as a yieldable buffer for the C-shaped portions of the shank.

15 6. A door check having an attaching plate, a shank, and a cushioning element, the shank extending freely through the attaching plate and being formed from a single strand of wire, said shank being provided at one end with an eye for an anchorage member and provided at its other end with a laterally extending portion, said shank being movable longitudinally through the attaching plate, the cushioning element being a coil formed from another strand of wire and being sleeved in substantially concentric relation upon the shank between the attaching plate and laterally extending portion aforesaid.

PAUL H. TRAVIS.