

J. J. RYAN & T. DIEM.
 APPARATUS FOR CLEANING BEER PIPES.
 APPLICATION FILED JULY 28, 1910.

988,899.

Patented Apr. 4, 1911.

2 SHEETS—SHEET 1.

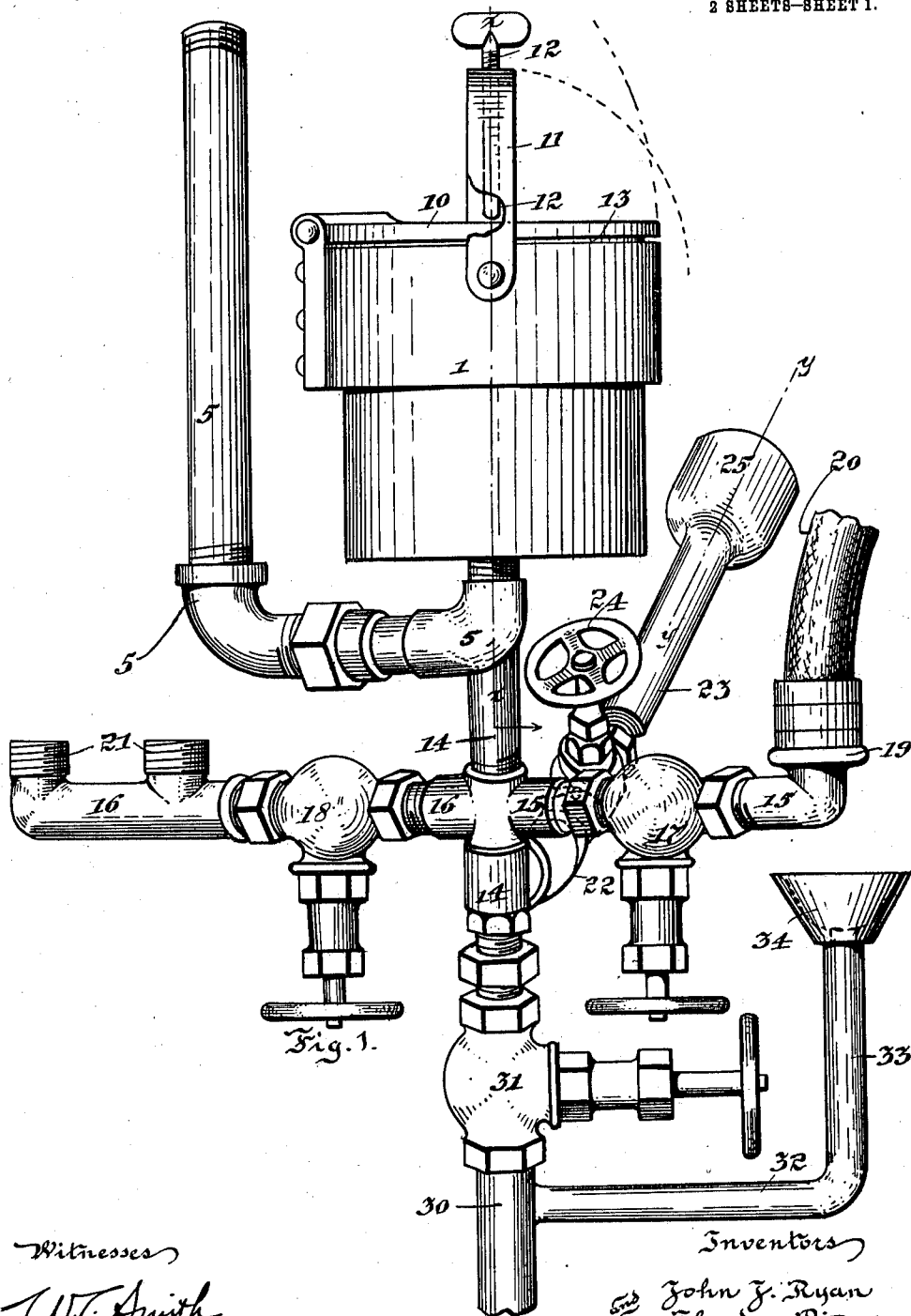

Witnesses
W. B. Smith
B. G. Richards

Inventors
 John J. Ryan
 Theodore Diem
 by *Joshua H. Felle*
 their Attorney.

J. J. RYAN & T. DIEM.
 APPARATUS FOR CLEANING BEER PIPES.
 APPLICATION FILED JULY 28, 1910.

988,899.

Patented Apr. 4, 1911.

2 SHEETS-SHEET 2.

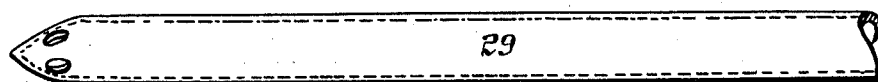

Fig. 2.

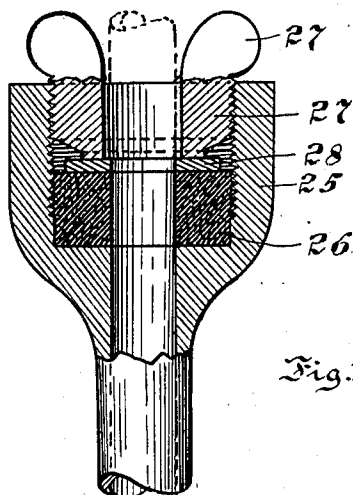

Fig. 3.

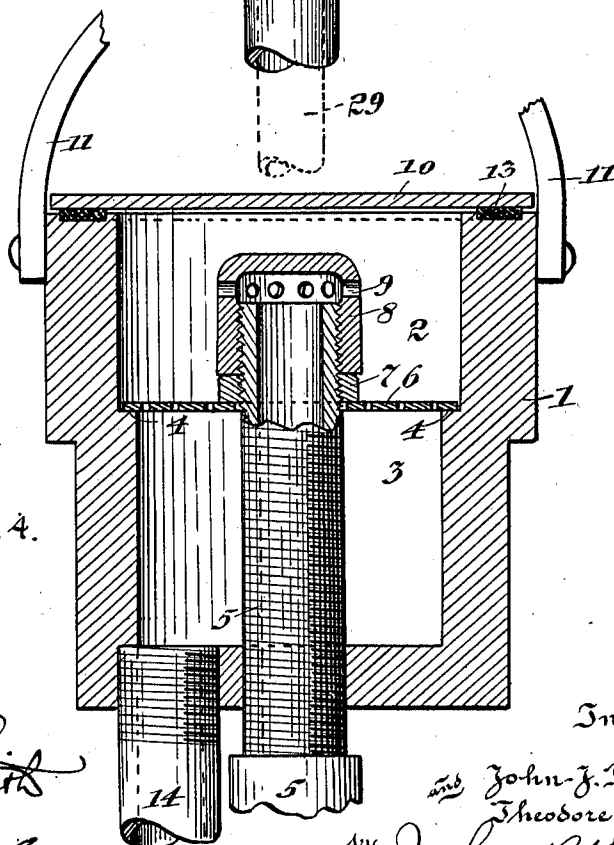

Fig. 4.

Witnesses
W. B. Smith
B. G. Richards

Inventors
John J. Ryan
Theodore Diem
 by *Joshua R. K. Foster*
 their Attorney

UNITED STATES PATENT OFFICE.

JOHN J. RYAN AND THEODORE DIEM, OF CHICAGO, ILLINOIS; SAID DIEM ASSIGNOR TO SAID RYAN.

APPARATUS FOR CLEANING BEER-PIPES.

988,899.

Specification of Letters Patent.

Patented Apr. 4, 1911.

Application filed July 28, 1910. Serial No. 574,340.

To all whom it may concern:

Be it known that we, JOHN J. RYAN and THEODORE DIEM, citizens of the United States, residing at Chicago, county of Cook, and State of Illinois, have invented certain new and useful Improvements in Apparatus for Cleaning Beer-Pipes, of which the following is a specification.

Our invention relates to improvements in apparatus for cleaning beer pipes and has for its object the provision of such an apparatus which shall be of simple construction and efficient in operation.

The invention consists in the combination and arrangement of parts hereinafter described and claimed.

The invention will be best understood by reference to the accompanying drawings forming a part of this specification, and in which,

Figure 1 is a perspective view of an apparatus embodying our invention, Fig. 2 is a partial elevation of a tapping stem employed in connection with the apparatus, Fig. 3 is an enlarged section on line $y-y$ of Fig. 1, and Fig. 4 is an enlarged section on line $x-x$ of Fig. 1.

The preferred form of construction as illustrated in the drawings comprises a receptacle 1 having an upper larger cylindrical compartment 2 and a lower smaller cylindrical compartment 3 therein, an annular shoulder 4 being formed between said compartments, as shown in Fig. 4. Threaded in a central opening in the bottom of compartment 3 is a pipe 5 extending upwardly into compartment 2. A perforated plate 6 is provided with a central opening adapted to fit over the upper end of pipe 5 and rests upon shoulder 4. Plate 6 is secured in position on shoulder 4 by means of a nut 7 threaded onto pipe 5. A cap 8 is threaded over the upper end of pipe 5 and is provided with discharge openings 9 in its sides. Receptacle 1 is provided with a hinged lid 10 and a hinged strap or bail 11 carrying a set-screw 12 arranged to contact with the top of lid 10 and holding the same in closed position. A packing ring 13 is inserted in an annular groove in the upper edge of receptacle 1 and serves to seal said receptacle when said lid is closed. A discharge pipe 14 is threaded into the bottom of compartment 3 and serves to permit the escape of fluid therefrom. A cleansing compound is placed

in compartment 2 around cap 3, and pipe 5 is connected with the usual water supply pipes or other source of water under pressure. By this arrangement it will be observed that water may be admitted to compartment 2 through pipe 5, passed through the compound in said compartment absorbing a portion of the same and discharged through pipe 14. Pipe 14 is provided with branches 15 and 16 each in turn provided with valves 17 and 18 by means of which the communication with discharge pipe 14 may be opened or closed as desired. Branch pipe 15 carries at its outer end an upwardly projecting threaded nipple 19 to which a flexible tube 20 may be removably secured. Branch pipe 16 is provided with two similar threaded nipples 21 to which other flexible tubes may be secured if desired. Another branch pipe 22 is connected with pipe 14 and carries at its outer end an upwardly inclined tube 23, a valve 24 being interposed in tube 22 for the purpose of opening or closing the connection between pipe 14 and tube 23. At its upper end tube 23 is provided with an enlargement or cup 25 which contains a centrally perforated packing ring 26 of rubber or other suitable material. A centrally perforated packing nut 27 is threaded into cup 25 and serves to compress packing ring 26 through the medium of a washer 28 interposed between the two. By this construction it will be observed that one or more flexible tubes 20 may be placed in communication with discharge tube 14 or that a tapping stem 29 may be readily inserted into tube 23 and placed in communication with pipe 14.

The apparatus is intended to be mounted in a refrigerator in close proximity to the place where the beer is kept. When it is desired to clean the beer faucets and their connections, either the tapping stem 29 may be withdrawn from a keg or barrel and inserted in tube 23 and valve 24 turned to open communication with pipe 14, or the flexible tube 20 which connects the faucet pipes with tapping stem 29 may be removed from tapping stem 29 and connected with one of the threaded nipples 19 or 21 and the corresponding valve opened to place the same in communication with discharge pipe 14. In either case the cleansing fluid will be forced upwardly through the faucet and its connections, discharging through the faucet.

Pipe 14 connects at its lower end with a drain pipe 30 through the medium of a valve 31 and a branch drain pipe 32 is provided with an upwardly turned end 33 carrying a drip funnel 34 located below and adjacent to nipple 19. By this arrangement it will be seen that when the cleansing process is finished a system may be readily drained by manipulation of the valves and that the ends of the different tubes 20 may be placed in funnel 34 to permit any drippings therefrom to run off.

While we have shown what we deem to be the preferable form of our invention, we do not wish to be limited thereto as there might be various changes made in the details of construction and arrangement of parts described without departing from the spirit of the invention. We therefore do not wish to be limited to the exact details set forth but desire to avail ourselves of such variations and modifications as come within the scope of the appended claims.

Having described our invention what we claim as new and desire to secure by Letters Patent is:

1. In a device of the class described, the combination of a closed receptacle for containing a cleaning compound; a water supply for said receptacle; a discharge pipe for said receptacle; means for receiving a tapping stem connected with said discharge pipe; a drain pipe for said discharge pipe; means for connecting a flexible tube with said discharge pipe; a drain funnel arranged adjacent said flexible tube connection; and a branch drain connecting said funnel with said drain pipe, substantially as described.

2. In a device of the class described, the combination of a receptacle comprising a larger upper compartment and a smaller lower compartment with an annular shoulder

between them; a lid for said receptacle; a water supply pipe extending upwardly through the center of said smaller compartment into said larger compartment; a perforated plate having a central opening fitting over said supply pipe and resting upon said shoulder; a nut threaded on said pipe and adapted to hold said plate to position on said shoulder; a cap threaded on the upper end of said supply pipe and provided with discharge openings in its sides; and a discharge pipe leading from said smaller chamber, substantially as described.

3. In a device of the class described, the combination of a receptacle comprising a larger upper compartment and a smaller lower compartment with an annular shoulder between them; a lid for said receptacle; a water supply pipe extending upwardly through the center of said smaller compartment into said larger compartment; a perforated plate having a central opening fitting over said supply pipe and resting upon said shoulder; a nut threaded on said pipe and adapted to hold said plate to position on said shoulder; a cap threaded on the upper end of said supply pipe and provided with discharge openings in its sides; a discharge pipe leading from said smaller chamber; means for receiving a tapping stem connected with said discharge pipe; and means for connecting a flexible tube with said discharge pipe, substantially as described.

In testimony whereof we have signed our names to this specification in the presence of two subscribing witnesses.

JOHN J. RYAN.
THEODORE DIEM.

Witnesses:

HELEN F. LILLIS,
JOSHUA R. H. POTTS.