

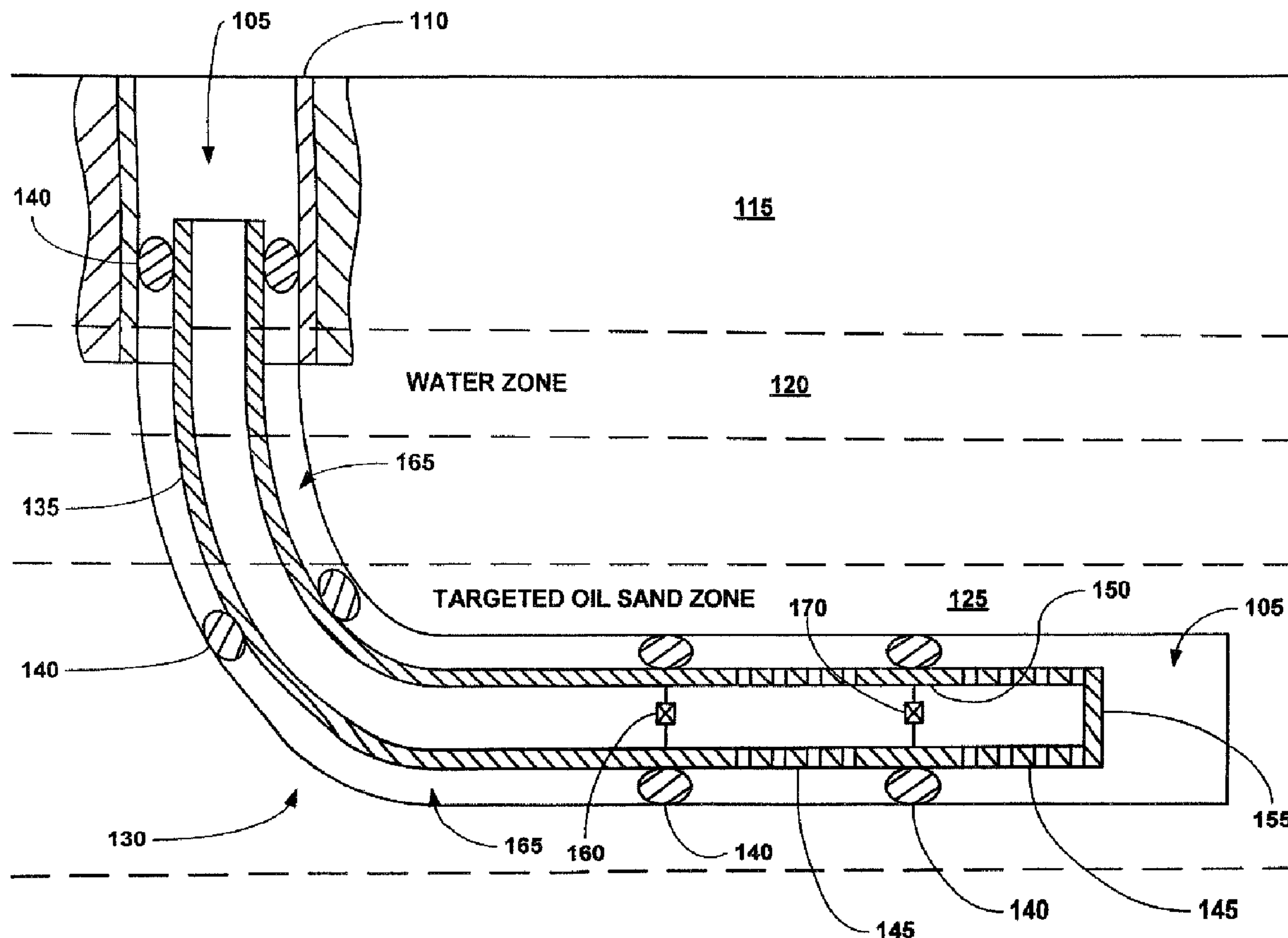

(22) Date de dépôt/Filing Date: 2004/07/12  
(41) Mise à la disp. pub./Open to Public Insp.: 2005/01/14  
(30) Priorité/Priority: 2003/07/14 (10/619,285) US

(51) Cl.Int.<sup>7</sup>/Int.Cl.<sup>7</sup> E21B 33/12, E21B 43/16  
(71) Demandeur/Applicant:  
ENVENTURE GLOBAL TECHNOLOGY, US  
(72) Inventeurs/Inventors:  
COOK, ROBERT LANCE, US;  
WADDELL, KEVIN KARL, US;  
BRISCO, DAVID PAUL, US;  
RAO, VIKRAM, US;  
RING, LEV, US  
(74) Agent: KIRBY EADES GALE BAKER

(54) Titre : ISOLEMENT DE ZONES SOUTERRAINES  
(54) Title: ISOLATION OF SUBTERRANEAN ZONES



(57) Abrégé/Abstract:  
One or more subterranean zones are isolated from one or more other subterranean zones using a combination of solid tubulars and perforated tubulars.

25791.292

**Abstract of the Disclosure**

**[0141]** One or more subterranean zones are isolated from one or more other subterranean zones using a combination of solid tubulars and perforated tubulars.

25791.292

**ISOLATION OF SUBTERRANEAN ZONES****Cross Reference to Related Applications**

**[0001]** This application is a continuation-in-part of U.S. patent application serial number 09/969,922, attorney docket number 25791.69, filed on 10/3/2001, which issued as U.S. Patent No. 6,634,431, which was a continuation-in-part of U.S. patent application serial number 09/440,338, attorney docket number 25791.9.02, filed on 11/15/1999, which issued as U.S. Patent No. 6,328,113, which claimed the benefit of the filing date of U.S. provisional patent application serial number 60/108,558, attorney docket number 25791.9, filed on 11/16/1998, the disclosures of which are incorporated herein by reference.

**[0002]** The present application is related to the following: (1) U.S. patent application serial no. 09/454,139, attorney docket no. 25791.03.02, filed on 12/3/1999, (2) U.S. patent application serial no. 09/510,913, attorney docket no. 25791.7.02, filed on 2/23/2000, (3) U.S. patent application serial no. 09/502,350, attorney docket no. 25791.8.02, filed on 2/10/2000, (4) U.S. patent application serial no. 09/440,338, attorney docket no. 25791.9.02, filed on 11/15/1999, (5) U.S. patent application serial no. 09/523,460, attorney docket no. 25791.11.02, filed on 3/10/2000, (6) U.S. patent application serial no. 09/512,895, attorney docket no. 25791.12.02, filed on 2/24/2000, (7) U.S. patent application serial no. 09/511,941, attorney docket no. 25791.16.02, filed on 2/24/2000, (8) U.S. patent application serial no. 09/588,946, attorney docket no. 25791.17.02, filed on 6/7/2000, (9) U.S. patent application serial no. 09/559,122, attorney docket no. 25791.23.02, filed on 4/26/2000, (10) PCT patent application serial no. PCT/US00/18635, attorney docket no. 25791.25.02, filed on 7/9/2000, (11) U.S. provisional patent application serial no. 60/162,671, attorney docket no. 25791.27, filed on 11/1/1999, (12) U.S. provisional patent application serial no. 60/154,047, attorney docket no. 25791.29, filed on 9/16/1999, (13) U.S. provisional patent application serial no. 60/159,082, attorney docket no. 25791.34, filed on 10/12/1999, (14) U.S. provisional patent application serial no. 60/159,039, attorney docket no. 25791.36, filed on 10/12/1999, (15) U.S. provisional patent application serial no. 60/159,033, attorney docket no. 25791.37, filed on 10/12/1999, (16) U.S. provisional patent application serial no. 60/212,359, attorney docket no. 25791.38, filed on 6/19/2000, (17) U.S. provisional patent application serial no. 60/165,228, attorney docket no. 25791.39,

25791.292

filed on 11/12/1999, (18) U.S. provisional patent application serial no. 60/221,443, attorney docket no. 25791.45, filed on 7/28/2000, (19) U.S. provisional patent application serial no. 60/221,645, attorney docket no. 25791.46, filed on 7/28/2000, (20) U.S. provisional patent application serial no. 60/233,638, attorney docket no. 25791.47, filed on 9/18/2000, (21) U.S. provisional patent application serial no. 60/237,334, attorney docket no. 25791.48, filed on 10/2/2000, (22) U.S. provisional patent application serial no. 60/270,007, attorney docket no. 25791.50, filed on 2/20/2001; (23) U.S. provisional patent application serial no. 60/262,434, attorney docket no. 25791.51, filed on 1/17/2001; (24) U.S. provisional patent application serial no. 60/259,486, attorney docket no. 25791.52, filed on 1/3/2001; (25) U.S. provisional patent application serial no. 60/303,740, attorney docket no. 25791.61, filed on 7/6/2001; (26) U.S. provisional patent application serial no. 60/313,453, attorney docket no. 25791.59, filed on 8/20/2001; (27) U.S. provisional patent application serial no. 60/317,985, attorney docket no. 25791.67, filed on 9/6/2001; and (28) U.S. provisional patent application serial no. 60/318,386, attorney docket no. 25791.67.02, filed on 9/10/2001, the disclosures of which are incorporated herein by reference.

#### **Background of the Invention**

[0003] This invention relates generally to oil and gas exploration, and in particular to isolating certain subterranean zones to facilitate oil and gas exploration.

[0004] During oil exploration, a wellbore typically traverses a number of zones within a subterranean formation. Some of these subterranean zones will produce oil and gas, while others will not. Further, it is often necessary to isolate subterranean zones from one another in order to facilitate the exploration for and production of oil and gas. Existing methods for isolating subterranean production zones in order to facilitate the exploration for and production of oil and gas are complex and expensive.

[0005] The present invention is directed to overcoming one or more of the limitations of the existing processes for isolating subterranean zones during oil and gas exploration.

#### **Summary of the Invention**

[0006] According to one aspect of the present invention, an apparatus is provided that includes a zonal isolation assembly including: one or more solid

25791.292

tubular members, each solid tubular member including one or more external seals; and one or more perforated tubular members coupled to the solid tubular members; and a shoe coupled to the zonal isolation assembly. One or more of the perforated tubular members include an elastic sealing member coupled to the perforated tubular member and covering one or more of the perforations of the perforated tubular member.

**[0007]** According to another aspect of the present invention, an apparatus is provided that includes a zonal isolation assembly including one or more primary solid tubulars, each primary solid tubular including one or more external seals;  $n$  perforated tubulars coupled to the primary solid tubulars; and  $n-1$  intermediate solid tubulars coupled to and interleaved among the perforated tubulars, each intermediate solid tubular including one or more external seals; and a shoe coupled to the zonal isolation assembly. One or more of the perforated tubular members include an elastic sealing member coupled to the perforated tubular member and covering one or more of the perforations of the perforated tubular member.

**[0008]** According to another aspect of the present invention, a method of isolating a first subterranean zone from a second subterranean zone in a wellbore is provided that includes positioning one or more primary solid tubulars within the wellbore, the primary solid tubulars traversing the first subterranean zone, positioning one or more perforated tubulars within the wellbore, the perforated tubulars traversing the second subterranean zone, fluidically coupling the perforated tubulars and the primary solid tubulars, preventing the passage of fluids from the first subterranean zone to the second subterranean zone within the wellbore external to the solid and perforated tubulars, and covering one or more of the perforations of one or more of the perforated tubular members using an elastic sealing member.

**[0009]** According to another aspect of the present invention, a method of extracting materials from a producing subterranean zone in a wellbore, at least a portion of the wellbore including a casing is provided that includes positioning one or more primary solid tubulars within the wellbore, fluidically coupling the primary solid tubulars with the casing, positioning one or more perforated tubulars within the wellbore, the perforated tubulars traversing the producing subterranean zone, fluidically coupling the perforated tubulars with the primary solid tubulars, fluidically isolating the producing subterranean zone from at least one other subterranean

25791.292

zone within the wellbore, fluidically coupling at least one of the perforated tubulars with the producing subterranean zone, and covering one or more of the perforations of one or more of the perforated tubular members using an elastic sealing member.

**[0010]** According to another aspect of the present invention, an apparatus is provided that includes a subterranean formation including a wellbore, a zonal isolation assembly at least partially positioned within the wellbore including: one or more solid tubular members, each solid tubular member including one or more external seals, and one or more perforated tubular members coupled to the solid tubular members, and a shoe positioned within the wellbore coupled to the zonal isolation assembly. At least one of the solid tubular members and the perforated tubular members are formed by a radial expansion process performed within the wellbore, and one or more of the perforated tubular members include an elastic sealing member coupled to the perforated tubular member and covering one or more of the perforations of the perforated tubular member.

**[0011]** According to another aspect of the present invention, an apparatus is provided that includes a subterranean formation including a wellbore, a zonal isolation assembly positioned within the wellbore including: one or more primary solid tubulars, each primary solid tubular including one or more external seals,  $n$  perforated tubulars positioned coupled to the primary solid tubulars, and  $n-1$  intermediate solid tubulars coupled to and interleaved among the perforated tubulars, each intermediate solid tubular including one or more external seals, and a shoe coupled to the zonal isolation assembly. At least one of the primary solid tubulars, the perforated tubulars, and the intermediate solid tubulars are formed by a radial expansion process performed within the wellbore, and one or more of the perforated tubular members include an elastic sealing member coupled to the perforated tubular member and covering one or more of the perforations of the perforated tubular member.

**[0012]** According to another aspect of the present invention, a method of isolating a first subterranean zone from a second subterranean zone in a wellbore is provided that includes positioning one or more primary solid tubulars within the wellbore, the primary solid tubulars traversing the first subterranean zone, positioning one or more perforated tubulars within the wellbore, the perforated tubulars traversing the second subterranean zone, radially expanding at least one

25791.292

of the primary solid tubulars and perforated tubulars within the wellbore, fluidically coupling the perforated tubulars and the primary solid tubulars, preventing the passage of fluids from the first subterranean zone to the second subterranean zone within the wellbore external to the primary solid tubulars and perforated tubulars, and covering one or more of the perforations of one or more of the perforated tubular members using an elastic sealing member.

**[0013]** According to another aspect of the present invention, a method of extracting materials from a producing subterranean zone in a wellbore, at least a portion of the wellbore including a casing, is provided that includes positioning one or more primary solid tubulars within the wellbore, positioning one or more perforated tubulars within the wellbore, the perforated tubulars traversing the producing subterranean zone, radially expanding at least one of the primary solid tubulars and the perforated tubulars within the wellbore, fluidically coupling the primary solid tubulars with the casing, fluidically coupling the perforated tubulars with the primary solid tubulars, fluidically isolating the producing subterranean zone from at least one other subterranean zone within the wellbore, fluidically coupling at least one of the perforated tubulars with the producing subterranean zone, and covering one or more of the perforations of one or more of the perforated tubular members using an elastic sealing member.

**[0014]** According to another aspect of the present invention, an apparatus is provided that includes a subterranean formation including a wellbore, a zonal isolation assembly positioned within the wellbore including:  $n$  solid tubular members positioned within the wellbore, each solid tubular member including one or more external seals, and  $n-1$  perforated tubular members positioned within the wellbore coupled to and interleaved among the solid tubular members, and a shoe positioned within the wellbore coupled to the zonal isolation assembly. One or more of the perforated tubular members include a tubular elastic sealing member coupled to the perforated tubular member and covering one or more of the perforations of the perforated tubular member.

**[0015]** According to another aspect of the present invention, a system for isolating a first subterranean zone from a second subterranean zone in a wellbore is provided that includes means for positioning one or more primary solid tubulars within the wellbore, the primary solid tubulars traversing the first subterranean zone, means for positioning one or more perforated tubulars within the wellbore,

25791.292

the perforated tubulars traversing the second subterranean zone, means for fluidicly coupling the perforated tubulars and the primary solid tubulars, means for preventing the passage of fluids from the first subterranean zone to the second subterranean zone within the wellbore external to the primary solid tubulars and the perforated tubulars, and means for sealing one or more of the perforations of one or more of the perforated tubular members.

**[0016]** According to another aspect of the present invention, a system for extracting materials from a producing subterranean zone in a wellbore, at least a portion of the wellbore including a casing, is provided that includes means for positioning one or more primary solid tubulars within the wellbore, means for fluidicly coupling the primary solid tubulars with the casing, means for positioning one or more perforated tubulars within the wellbore, the perforated tubulars traversing the producing subterranean zone, means for fluidicly coupling the perforated tubulars with the primary solid tubulars, means for fluidicly isolating the producing subterranean zone from at least one other subterranean zone within the wellbore, means for fluidicly coupling at least one of the perforated tubulars with the producing subterranean zone, and means for sealing one or more of the perforations of one or more of the perforated tubular members using an elastic sealing member.

**[0017]** According to another aspect of the present invention, a system for isolating a first subterranean zone from a second subterranean zone in a wellbore is provided that includes means for positioning one or more primary solid tubulars within the wellbore, the primary solid tubulars traversing the first subterranean zone, means for positioning one or more perforated tubulars within the wellbore, the perforated tubulars traversing the second subterranean zone, means for radially expanding at least one of the primary solid tubulars and perforated tubulars within the wellbore, means for fluidicly coupling the perforated tubulars and the primary solid tubulars, means for preventing the passage of fluids from the first subterranean zone to the second subterranean zone within the wellbore external to the primary solid tubulars and perforated tubulars, and means for sealing one or more of the perforations of one or more of the perforated tubular members using an elastic sealing member.

**[0018]** According to another aspect of the present invention, a system for extracting materials from a producing subterranean zone in a wellbore, at least a

25791.292

portion of the wellbore including a casing, is provided that includes means for positioning one or more primary solid tubulars within the wellbore, means for positioning one or more perforated tubulars within the wellbore, the perforated tubulars traversing the producing subterranean zone, means for radially expanding at least one of the primary solid tubulars and the perforated tubulars within the wellbore, means for fluidicly coupling the primary solid tubulars with the casing, means for fluidicly coupling the perforated tubulars with the solid tubulars, means for fluidicly isolating the producing subterranean zone from at least one other subterranean zone within the wellbore, means for fluidicly coupling at least one of the perforated tubulars with the producing subterranean zone, and means for sealing one or more of the perforations of one or more of the perforated tubular members using an elastic sealing member.

**[0019]** According to another aspect of the present invention, a system for isolating subterranean zones traversed by a wellbore is provided that includes a tubular support member defining a first passage, a tubular expansion cone defining a second passage fluidicly coupled to the first passage coupled to an end of the tubular support member and comprising a tapered end, a tubular liner coupled to and supported by the tapered end of the tubular expansion cone, and a shoe defining a valveable passage coupled to an end of the tubular liner. The tubular liner includes one or more expandable tubular members that each include: a tubular body comprising an intermediate portion and first and second expanded end portions coupled to opposing ends of the intermediate portion, and a sealing member coupled to the exterior surface of the intermediate portion, and one or more perforated tubular members coupled to the expandable tubular members. The inside diameters of the perforated tubular members are greater than or equal to the outside diameter of the tubular expansion cone.

**[0020]** According to another aspect of the present invention, a method of isolating subterranean zones traversed by a wellbore is provided that includes positioning a tubular liner within the wellbore, and radially expanding one or more discrete portions of the tubular liner into engagement with the wellbore. The tubular liner includes a plurality of tubular members, and one or more of the tubular members are radially expanded into engagement with the wellbore and one or more of the tubular members are not radially expanded into engagement with the wellbore. The tubular liner includes one or more expandable tubular members that

25791.292

each include: a tubular body comprising an intermediate portion and first and second expanded end portions coupled to opposing ends of the intermediate portion, and a sealing member coupled to the exterior surface of the intermediate portion, and one or more perforated tubular members coupled to the expandable tubular members. The inside diameters of the perforated tubular members are greater than or equal to the maximum inside diameters of the expandable tubular members.

**[0021]** According to another aspect of the present invention, an apparatus for isolating subterranean zones is provided that includes a subterranean formation defining a borehole, and a tubular liner positioned in and coupled to the borehole at one or more discrete locations. The tubular liner includes a plurality of tubular members, and one or more of the tubular members are radially expanded into engagement with the borehole and one or more of the tubular members are not radially expanded into engagement with the borehole. The tubular liner is coupled to the borehole by a process that includes positioning the tubular liner within the borehole, and radially expanding one or more discrete portions of the tubular liner into engagement with the borehole.

**[0022]** According to another aspect of the present invention, a method of sealing an annulus between a wellbore and a tubular member positioned within the wellbore is provided that includes coupling a swellable elastomeric material to the exterior of the tubular member that swells in the presence of fluidic materials to sealingly engage the wellbore.

#### **Brief Description of the Drawings**

**[0023]** FIG. 1 is a fragmentary cross-sectional view illustrating the isolation of subterranean zones.

**[0024]** Fig. 2a is a cross sectional illustration of the placement of an illustrative embodiment of a system for isolating subterranean zones within a borehole.

**[0025]** Fig. 2b is a cross sectional illustration of the system of Fig. 2a during the injection of a fluidic material into the tubular support member.

**[0026]** Fig. 2c is a cross sectional illustration of the system of Fig. 2b while pulling the tubular expansion cone out of the wellbore.

**[0027]** Fig. 2d is a cross sectional illustration of the system of Fig. 2c after the tubular expansion cone has been completely pulled out of the wellbore.

25791.292

[0028] Fig. 3 is a cross sectional illustration of an illustrative embodiment of the expandable tubular members of the system of Fig. 2a.

[0029] Fig. 4 is a flow chart illustration of an illustrative embodiment of a method for manufacturing the expandable tubular member of Fig. 3.

[0030] Fig. 5a is a cross sectional illustration of an illustrative embodiment of the upsetting of the ends of a tubular member.

[0031] Fig. 5b is a cross sectional illustration of the expandable tubular member of Fig. 5a after radially expanding and plastically deforming the ends of the expandable tubular member.

[0032] Fig. 5c is a cross sectional illustration of the expandable tubular member of Fig. 5b after forming threaded connections on the ends of the expandable tubular member.

[0033] Fig. 5d is a cross sectional illustration of the expandable tubular member of Fig. 5c after coupling sealing members to the exterior surface of the intermediate unexpanded portion of the expandable tubular member.

[0034] Fig. 6 is a cross-sectional illustration of an exemplary embodiment of a tubular expansion cone.

[0035] Fig. 7 is a cross-sectional illustration of an exemplary embodiment of a tubular expansion cone.

[0036] Fig. 8a is a fragmentary cross-sectional illustration of an exemplary embodiment of a perforated tubular member that includes an elastic tubular sealing member coupled to the perforated tubular member.

[0037] Fig. 8b is a fragmentary cross-sectional illustration of the perforated tubular member of Fig. 8a after the swelling of the sealing member.

#### **Detailed Description of the Illustrative Embodiments**

[0038] An apparatus and method for isolating one or more subterranean zones from one or more other subterranean zones is provided. The apparatus and method permits a producing zone to be isolated from a nonproducing zone using a combination of solid and slotted tubulars. In the production mode, the teachings of the present disclosure may be used in combination with conventional, well known, production completion equipment and methods using a series of packers, solid tubing, perforated tubing, and sliding sleeves, which will be inserted into the disclosed apparatus to permit the commingling and/or isolation of the subterranean zones from each other.

25791.292

**[0039]** Referring to Fig. 1, a wellbore 105 including a casing 110 are positioned in a subterranean formation 115. The subterranean formation 115 includes a number of productive and non-productive zones, including a water zone 120 and a targeted oil sand zone 125. During exploration of the subterranean formation 115, the wellbore 105 may be extended in a well known manner to traverse the various productive and non-productive zones, including the water zone 120 and the targeted oil sand zone 125.

**[0040]** In a preferred embodiment, in order to fluidically isolate the water zone 120 from the targeted oil sand zone 125, an apparatus 130 is provided that includes one or more sections of solid casing 135, one or more external seals 140, one or more sections of slotted casing 145, one or more intermediate sections of solid casing 150, and a solid shoe 155.

**[0041]** The solid casing 135 may provide a fluid conduit that transmits fluids and other materials from one end of the solid casing 135 to the other end of the solid casing 135. The solid casing 135 may comprise any number of conventional commercially available sections of solid tubular casing such as, for example, oilfield tubulars fabricated from chromium steel or fiberglass. In a preferred embodiment, the solid casing 135 comprises oilfield tubulars available from various foreign and domestic steel mills.

**[0042]** The solid casing 135 is preferably coupled to the casing 110. The solid casing 135 may be coupled to the casing 110 using any number of conventional commercially available processes such as, for example, welding, slotted and expandable connectors, or expandable solid connectors. In a preferred embodiment, the solid casing 135 is coupled to the casing 110 by using expandable solid connectors. The solid casing 135 may comprise a plurality of such solid casing 135.

**[0043]** The solid casing 135 is preferably coupled to one more of the slotted casings 145. The solid casing 135 may be coupled to the slotted casing 145 using any number of conventional commercially available processes such as, for example, welding, or slotted and expandable connectors. In a preferred embodiment, the solid casing 135 is coupled to the slotted casing 145 by expandable solid connectors.

**[0044]** In a preferred embodiment, the casing 135 includes one more valve members 160 for controlling the flow of fluids and other materials within the interior

25791.292

region of the casing 135. In an alternative embodiment, during the production mode of operation, an internal tubular string with various arrangements of packers, perforated tubing, sliding sleeves, and valves may be employed within the apparatus to provide various options for commingling and isolating subterranean zones from each other while providing a fluid path to the surface.

**[0045]** In a particularly preferred embodiment, the casing 135 is placed into the wellbore 105 by expanding the casing 135 in the radial direction into intimate contact with the interior walls of the wellbore 105. The casing 135 may be expanded in the radial direction using any number of conventional commercially available methods.

**[0046]** The seals 140 prevent the passage of fluids and other materials within the annular region 165 between the solid casings 135 and 150 and the wellbore 105. The seals 140 may comprise any number of conventional commercially available sealing materials suitable for sealing a casing in a wellbore such as, for example, lead, rubber or epoxy. In a preferred embodiment, the seals 140 comprise Stratalok epoxy material available from Halliburton Energy Services. The slotted casing 145 permits fluids and other materials to pass into and out of the interior of the slotted casing 145 from and to the annular region 165. In this manner, oil and gas may be produced from a producing subterranean zone within a subterranean formation. The slotted casing 145 may comprise any number of conventional commercially available sections of slotted tubular casing. In a preferred embodiment, the slotted casing 145 comprises expandable slotted tubular casing available from Petrolin in Aberdeen, Scotland. In a particularly preferred embodiment, the slotted casing 145 comprises expandable slotted sandscreen tubular casing available from Petrolin in Aberdeen, Scotland.

**[0047]** The slotted casing 145 is preferably coupled to one or more solid casing 135. The slotted casing 145 may be coupled to the solid casing 135 using any number of conventional commercially available processes such as, for example, welding, or slotted or solid expandable connectors. In a preferred embodiment, the slotted casing 145 is coupled to the solid casing 135 by expandable solid connectors.

**[0048]** The slotted casing 145 is preferably coupled to one or more intermediate solid casings 150. The slotted casing 145 may be coupled to the intermediate solid casing 150 using any number of conventional commercially available processes

25791.292

such as, for example, welding or expandable solid or slotted connectors. In a preferred embodiment, the slotted casing 145 is coupled to the intermediate solid casing 150 by expandable solid connectors.

**[0049]** The last slotted casing 145 is preferably coupled to the shoe 155. The last slotted casing 145 may be coupled to the shoe 155 using any number of conventional commercially available processes such as, for example, welding or expandable solid or slotted connectors. In a preferred embodiment, the last slotted casing 145 is coupled to the shoe 155 by an expandable solid connector.

**[0050]** In an alternative embodiment, the shoe 155 is coupled directly to the last one of the intermediate solid casings 150.

**[0051]** In a preferred embodiment, the slotted casings 145 are positioned within the wellbore 105 by expanding the slotted casings 145 in a radial direction into intimate contact with the interior walls of the wellbore 105. The slotted casings 145 may be expanded in a radial direction using any number of conventional commercially available processes.

**[0052]** The intermediate solid casing 150 permits fluids and other materials to pass between adjacent slotted casings 145. The intermediate solid casing 150 may comprise any number of conventional commercially available sections of solid tubular casing such as, for example, oilfield tubulars fabricated from chromium steel or fiberglass. In a preferred embodiment, the intermediate solid casing 150 comprises oilfield tubulars available from foreign and domestic steel mills.

**[0053]** The intermediate solid casing 150 is preferably coupled to one or more sections of the slotted casing 145. The intermediate solid casing 150 may be coupled to the slotted casing 145 using any number of conventional commercially available processes such as, for example, welding, or solid or slotted expandable connectors. In a preferred embodiment, the intermediate solid casing 150 is coupled to the slotted casing 145 by expandable solid connectors. The intermediate solid casing 150 may comprise a plurality of such intermediate solid casing 150.

**[0054]** In a preferred embodiment, the each intermediate solid casing 150 includes one more valve members 170 for controlling the flow of fluids and other materials within the interior region of the intermediate casing 150. In an alternative embodiment, as will be recognized by persons having ordinary skill in the art and the benefit of the present disclosure, during the production mode of operation, an

25791.292

internal tubular string with various arrangements of packers, perforated tubing, sliding sleeves, and valves may be employed within the apparatus to provide various options for commingling and isolating subterranean zones from each other while providing a fluid path to the surface.

**[0055]** In a particularly preferred embodiment, the intermediate casing 150 is placed into the wellbore 105 by expanding the intermediate casing 150 in the radial direction into intimate contact with the interior walls of the wellbore 105. The intermediate casing 150 may be expanded in the radial direction using any number of conventional commercially available methods.

**[0056]** In an alternative embodiment, one or more of the intermediate solid casings 150 may be omitted. In an alternative preferred embodiment, one or more of the slotted casings 145 are provided with one or more seals 140.

**[0057]** The shoe 155 provides a support member for the apparatus 130. In this manner, various production and exploration tools may be supported by the shoe 150. The shoe 150 may comprise any number of conventional commercially available shoes suitable for use in a wellbore such as, for example, cement filled shoe, or an aluminum or composite shoe. In a preferred embodiment, the shoe 150 comprises an aluminum shoe available from Halliburton. In a preferred embodiment, the shoe 155 is selected to provide sufficient strength in compression and tension to permit the use of high capacity production and exploration tools.

**[0058]** In a particularly preferred embodiment, the apparatus 130 includes a plurality of solid casings 135, a plurality of seals 140, a plurality of slotted casings 145, a plurality of intermediate solid casings 150, and a shoe 155. More generally, the apparatus 130 may comprise one or more solid casings 135, each with one or more valve members 160, n slotted casings 145, n-1 intermediate solid casings 150, each with one or more valve members 170, and a shoe 155.

**[0059]** During operation of the apparatus 130, oil and gas may be controllably produced from the targeted oil sand zone 125 using the slotted casings 145. The oil and gas may then be transported to a surface location using the solid casing 135. The use of intermediate solid casings 150 with valve members 170 permits isolated sections of the zone 125 to be selectively isolated for production. The seals 140 permit the zone 125 to be fluidically isolated from the zone 120. The seals 140 further permits isolated sections of the zone 125 to be fluidically isolated from

25791.292

each other. In this manner, the apparatus 130 permits unwanted and/or non-productive subterranean zones to be fluidically isolated.

**[0060]** In an alternative embodiment, as will be recognized by persons having ordinary skill in the art and also having the benefit of the present disclosure, during the production mode of operation, an internal tubular string with various arrangements of packers, perforated tubing, sliding sleeves, and valves may be employed within the apparatus to provide various options for commingling and isolating subterranean zones from each other while providing a fluid path to the surface.

**[0061]** Referring to Figs. 2a-2d, an illustrative embodiment of a system 200 for isolating subterranean formations includes a tubular support member 202 that defines a passage 202a. A tubular expansion cone 204 that defines a passage 204a is coupled to an end of the tubular support member 202. In an exemplary embodiment, the tubular expansion cone 204 includes a tapered outer surface 204b for reasons to be described.

**[0062]** A pre-expanded end 206a of a first expandable tubular member 206 that defines a passage 206b is adapted to mate with and be supported by the tapered outer surface 204b of the tubular expansion cone 204. The first expandable tubular member 206 further includes an unexpanded intermediate portion 206c, another pre-expanded end 206d, and a sealing member 206e coupled to the exterior surface of the unexpanded intermediate portion. In an exemplary embodiment, the inside and outside diameters of the pre-expanded ends, 206a and 206d, of the first expandable tubular member 206 are greater than the inside and outside diameters of the unexpanded intermediate portion 206c. An end 208a of a shoe 208 is coupled to the pre-expanded end 206a of the first expandable tubular member 206 by a conventional threaded connection.

**[0063]** An end 210a of a slotted tubular member 210 that defines a passage 210b is coupled to the other pre-expanded end 206d of the first expandable tubular member 206 by a conventional threaded connection. Another end 210c of the slotted tubular member 210 is coupled to an end 212a of a slotted tubular member 212 that defines a passage 212b by a conventional threaded connection. A pre-expanded end 214a of a second expandable tubular member 214 that defines a passage 214b is coupled to the other end 212c of the tubular member 212. The second expandable tubular member 214 further includes an unexpanded

25791.292

intermediate portion 214c, another pre-expanded end 214d, and a sealing member 214e coupled to the exterior surface of the unexpanded intermediate portion. In an exemplary embodiment, the inside and outside diameters of the pre-expanded ends, 214a and 214d, of the second expandable tubular member 214 are greater than the inside and outside diameters of the unexpanded intermediate portion 214c.

**[0064]** An end 216a of a slotted tubular member 216 that defines a passage 216b is coupled to the other pre-expanded end 214d of the second expandable tubular member 214 by a conventional threaded connection. Another end 216c of the slotted tubular member 216 is coupled to an end 218a of a slotted tubular member 218 that defines a passage 218b by a conventional threaded connection. A pre-expanded end 220a of a third expandable tubular member 220 that defines a passage 220b is coupled to the other end 218c of the slotted tubular member 218. The third expandable tubular member 220 further includes an unexpanded intermediate portion 220c, another pre-expanded end 220d, and a sealing member 220e coupled to the exterior surface of the unexpanded intermediate portion. In an exemplary embodiment, the inside and outside diameters of the pre-expanded ends, 220a and 220d, of the third expandable tubular member 220 are greater than the inside and outside diameters of the unexpanded intermediate portion 220c.

**[0065]** An end 222a of a tubular member 222 is threadably coupled to the end 30d of the third expandable tubular member 220.

**[0066]** In an exemplary embodiment, the inside and outside diameters of the pre-expanded ends, 206a, 206d, 214a, 214d, 220a and 220d, of the expandable tubular members, 206, 214, and 220, and the slotted tubular members 210, 212, 216, and 218, are substantially equal. In several exemplary embodiments, the sealing members, 206e, 214e, and 220e, of the expandable tubular members, 206, 214, and 220, respectively, further include anchoring elements for engaging the wellbore casing 104. In several exemplary embodiments, the slotted tubular members, 210, 212, 216, and 218, are conventional slotted tubular members having threaded end connections suitable for use in an oil or gas well, an underground pipeline, or as a structural support. In several alternative embodiments, the slotted tubular members, 210, 212, 216, and 218 are conventional slotted tubular members for recovering or introducing fluidic materials such as, for example, oil, gas and/or water from or into a subterranean formation.

25791.292

**[0067]** In an exemplary embodiment, as illustrated in Fig. 2a, the system 200 is initially positioned in a borehole 224 formed in a subterranean formation 226 that includes a water zone 226a and a targeted oil sand zone 226b. The borehole 224 may be positioned in any orientation from vertical to horizontal. In an exemplary embodiment, the upper end of the tubular support member 202 may be supported in a conventional manner using, for example, a slip joint, or equivalent device in order to permit upward movement of the tubular support member and tubular expansion cone 204 relative to one or more of the expandable tubular members, 206, 214, and 220, and tubular members, 210, 212, 216, and 218.

**[0068]** In an exemplary embodiment, as illustrated in Fig. 2b, a fluidic material 228 is then injected into the system 200, through the passages, 202a and 204a, of the tubular support member 202 and tubular expansion cone 204, respectively.

**[0069]** In an exemplary embodiment, as illustrated in Fig. 2c, the continued injection of the fluidic material 228 through the passages, 202a and 204a, of the tubular support member 202 and the tubular expansion cone 204, respectively, pressurizes the passage 18b of the shoe 18 below the tubular expansion cone thereby radially expanding and plastically deforming the expandable tubular member 206 off of the tapered external surface 204b of the tubular expansion cone 204. In particular, the intermediate non pre-expanded portion 206c of the expandable tubular member 206 is radially expanded and plastically deformed off of the tapered external surface 204b of the tubular expansion cone 204. As a result, the sealing member 206e engages the interior surface of the wellbore casing 104. Consequently, the radially expanded intermediate portion 206c of the expandable tubular member 206 is thereby coupled to the wellbore casing 104. In an exemplary embodiment, the radially expanded intermediate portion 206c of the expandable tubular member 206 is also thereby anchored to the wellbore casing 104.

**[0070]** In an exemplary embodiment, as illustrated in Fig. 2d, after the expandable tubular member 206 has been plastically deformed and radially expanded off of the tapered external surface 204b of the tubular expansion cone 204, the tubular expansion cone is pulled out of the borehole 224 by applying an upward force to the tubular support member 202. As a result, the second and third expandable tubular members, 214 and 220, are radially expanded and plastically deformed off of the tapered external surface 204b of the tubular expansion cone

25791.292

204. In particular, the intermediate non pre-expanded portion 214c of the second expandable tubular member 214 is radially expanded and plastically deformed off of the tapered external surface 204b of the tubular expansion cone 204. As a result, the sealing member 214e engages the interior surface of the wellbore 224. Consequently, the radially expanded intermediate portion 214c of the second expandable tubular member 214 is thereby coupled to the wellbore 224. In an exemplary embodiment, the radially expanded intermediate portion 214c of the second expandable tubular member 214 is also thereby anchored to the wellbore 104. Furthermore, the continued application of the upward force to the tubular member 202 will then displace the tubular expansion cone 204 upwardly into engagement with the pre-expanded end 220a of the third expandable tubular member 220. Finally, the continued application of the upward force to the tubular member 202 will then radially expand and plastically deform the third expandable tubular member 220 off of the tapered external surface 204b of the tubular expansion cone 204. In particular, the intermediate non pre-expanded portion 220c of the third expandable tubular member 220 is radially expanded and plastically deformed off of the tapered external surface 204b of the tubular expansion cone 204. As a result, the sealing member 220e engages the interior surface of the wellbore 224. Consequently, the radially expanded intermediate portion 220c of the third expandable tubular member 220 is thereby coupled to the wellbore 224. In an exemplary embodiment, the radially expanded intermediate portion 220c of the third expandable tubular member 220 is also thereby anchored to the wellbore 224. As a result, the water zone 226a and fluidically isolated from the targeted oil sand zone 226b.

**[0071]** After completing the radial expansion and plastic deformation of the third expandable tubular member 220, the tubular support member 202 and the tubular expansion cone 204 are removed from the wellbore 224.

**[0072]** Thus, during the operation of the system 10, the intermediate non pre-expanded portions, 206c, 214c, and 220c, of the expandable tubular members, 206, 214, and 220, respectively, are radially expanded and plastically deformed by the upward displacement of the tubular expansion cone 204. As a result, the sealing members, 206e, 214e, and 220e, are displaced in the radial direction into engagement with the wellbore 224 thereby coupling the shoe 208, the expandable tubular member 206, the slotted tubular members, 210 and 212, the expandable

25791.292

tubular member 214, the slotted tubular members, 216 and 218, and the expandable tubular member 220 to the wellbore. Furthermore, as a result, the connections between the expandable tubular members, 206, 214, and 220, the shoe 208, and the slotted tubular members, 210, 212, 216, and 218, do not have to be expandable connections thereby providing significant cost savings. In addition, the inside diameters of the expandable tubular members, 206, 214, and 220, and the slotted tubular members, 210, 212, 216, and 218, after the radial expansion process, are substantially equal. In this manner, additional conventional tools and other conventional equipment may be easily positioned within, and moved through, the expandable and slotted tubular members. In several alternative embodiments, the conventional tools and equipment include conventional valving and other conventional flow control devices for controlling the flow of fluidic materials within and between the expandable tubular members, 206, 214, and 220, and the slotted tubular members, 210, 212, 216, and 218.

**[0073]** Furthermore, in the system 200, the slotted tubular members 210, 212, 216, and 218 are interleaved among the expandable tubular members, 206, 214, and 220. As a result, because only the intermediate non pre-expanded portions, 206c, 214c, and 220c, of the expandable tubular members, 206, 214, and 220, respectively, are radially expanded and plastically deformed, the slotted tubular members, 210, 212, 216, and 218 can be conventional slotted tubular members thereby significantly reducing the cost and complexity of the system 10. Moreover, because only the intermediate non pre-expanded portions, 206c, 214c, and 220c, of the expandable tubular members, 206, 214, and 220, respectively, are radially expanded and plastically deformed, the number and length of the interleaved slotted tubular members, 210, 212, 216, and 218 can be much greater than the number and length of the expandable tubular members. In an exemplary embodiment, the total length of the intermediate non pre-expanded portions, 206c, 214c, and 220c, of the expandable tubular members, 206, 214, and 220, is approximately 200 feet, and the total length of the slotted tubular members, 210, 212, 216, and 218, is approximately 3800 feet. Consequently, in an exemplary embodiment, a system 200 having a total length of approximately 4000 feet is coupled to the wellbore 224 by radially expanding and plastically deforming a total length of only approximately 200 feet.

25791.292

**[0074]** Furthermore, the sealing members 206e, 214e, and 220e, of the expandable tubular members, 206, 214, and 220, respectively, are used to couple the expandable tubular members and the slotted tubular members, 210, 212, 216, and 218 to the wellbore 224, the radial gap between the slotted tubular members, the expandable tubular members, and the wellbore 224 may be large enough to effectively eliminate the possibility of damage to the expandable tubular members and slotted tubular members during the placement of the system 200 within the wellbore.

**[0075]** In an exemplary embodiment, the pre-expanded ends, 206a, 206d, 214a, 214d, 220a, and 220d, of the expandable tubular members, 206, 214, and 220, respectively, and the slotted tubular members, 210, 212, 216, and 218, have outside diameters and wall thicknesses of 8.375 inches and 0.350 inches, respectively; prior to the radial expansion, the intermediate non pre-expanded portions, 206c, 214c, and 220c, of the expandable tubular members, 206, 214, and 220, respectively, have outside diameters of 7.625 inches; the slotted tubular members, 210, 212, 216, and 218, have inside diameters of 7.675 inches; after the radial expansion, the inside diameters of the intermediate portions, 206c, 214c, and 220c, of the expandable tubular members, 206, 214, and 220, are equal to 7.675 inches; and the wellbore 224 has an inside diameter of 8.755 inches.

**[0076]** In an exemplary embodiment, the pre-expanded ends, 206a, 206d, 214a, 214d, 220a, and 220d, of the expandable tubular members, 206, 214, and 220, respectively, and the slotted tubular members, 210, 212, 216, and 218, have outside diameters and wall thicknesses of 4.500 inches and 0.250 inches, respectively; prior to the radial expansion, the intermediate non pre-expanded portions, 206c, 214c, and 220c, of the expandable tubular members, 206, 214, and 220, respectively, have outside diameters of 4.000 inches; the slotted tubular members, 210, 212, 216, and 218, have inside diameters of 4.000 inches; after the radial expansion, the inside diameters of the intermediate portions, 206c, 214c, and 220c, of the expandable tubular members, 206, 214, and 220, are equal to 4.000 inches; and the wellbore 224 has an inside diameter of 4.892 inches.

**[0077]** In an exemplary embodiment, the system 200 is used to inject or extract fluidic materials such as, for example, oil, gas, and/or water into or from the subterranean formation 226b.

25791.292

**[0078]** Referring now to Fig. 3, an exemplary embodiment of an expandable tubular member 300 will now be described. The tubular member 300 defines an interior region 300a and includes a first end 300b including a first threaded connection 300ba, a first tapered portion 300c, an intermediate portion 300d, a second tapered portion 300e, and a second end 300f including a second threaded connection 300fa. The tubular member 300 further preferably includes an intermediate sealing member 300g that is coupled to the exterior surface of the intermediate portion 300d.

**[0079]** In an exemplary embodiment, the tubular member 300 has a substantially annular cross section. The tubular member 300 may be fabricated from any number of conventional commercially available materials such as, for example, Oilfield Country Tubular Goods (OCTG), 13 chromium steel tubing/casing, or L83, J55, or P110 API casing.

**[0080]** In an exemplary embodiment, the interior 300a of the tubular member 300 has a substantially circular cross section. Furthermore, in an exemplary embodiment, the interior region 300a of the tubular member includes a first inside diameter  $D_1$ , an intermediate inside diameter  $D_{INT}$ , and a second inside diameter  $D_2$ . In an exemplary embodiment, the first and second inside diameters,  $D_1$  and  $D_2$ , are substantially equal. In an exemplary embodiment, the first and second inside diameters,  $D_1$  and  $D_2$ , are greater than the intermediate inside diameter  $D_{INT}$ .

**[0081]** The first end 300b of the tubular member 300 is coupled to the intermediate portion 300d by the first tapered portion 300c, and the second end 300f of the tubular member is coupled to the intermediate portion by the second tapered portion 300e. In an exemplary embodiment, the outside diameters of the first and second ends, 300b and 300f, of the tubular member 300 is greater than the outside diameter of the intermediate portion 300d of the tubular member. The first and second ends, 300b and 300f, of the tubular member 300 include wall thicknesses,  $t_1$  and  $t_2$ , respectively. In an exemplary embodiment, the outside diameter of the intermediate portion 300d of the tubular member 300 ranges from about 75% to 98% of the outside diameters of the first and second ends, 300a and 300f. The intermediate portion 300d of the tubular member 300 includes a wall thickness  $t_{INT}$ .

**[0082]** In an exemplary embodiment, the wall thicknesses  $t_1$  and  $t_2$  are substantially equal in order to provide substantially equal burst strength for the first

25791.292

and second ends, 300a and 300f, of the tubular member 300. In an exemplary embodiment, the wall thicknesses,  $t_1$  and  $t_2$ , are both greater than the wall thickness  $t_{INT}$  in order to optimally match the burst strength of the first and second ends, 300a and 300f, of the tubular member 300 with the intermediate portion 300d of the tubular member 300.

**[0083]** In an exemplary embodiment, the first and second tapered portions, 300c and 300e, are inclined at an angle,  $\alpha$ , relative to the longitudinal direction ranging from about 0 to 30 degrees in order to optimally facilitate the radial expansion of the tubular member 300. In an exemplary embodiment, the first and second tapered portions, 300c and 300e, provide a smooth transition between the first and second ends, 300a and 300f, and the intermediate portion 300d, of the tubular member 300 in order to minimize stress concentrations.

**[0084]** The intermediate sealing member 300g is coupled to the outer surface of the intermediate portion 300d of the tubular member 300. In an exemplary embodiment, the intermediate sealing member 300g seals the interface between the intermediate portion 300d of the tubular member 300 and the interior surface of a wellbore casing 305, or other preexisting structure, after the radial expansion and plastic deformation of the intermediate portion 300d of the tubular member 300. In an exemplary embodiment, the intermediate sealing member 300g has a substantially annular cross section. In an exemplary embodiment, the outside diameter of the intermediate sealing member 300g is selected to be less than the outside diameters of the first and second ends, 300a and 300f, of the tubular member 300 in order to optimally protect the intermediate sealing member 300g during placement of the tubular member 300 within the wellbore casings 305. The intermediate sealing member 300g may be fabricated from any number of conventional commercially available materials such as, for example, thermoset or thermoplastic polymers. In an exemplary embodiment, the intermediate sealing member 300g is fabricated from thermoset polymers in order to optimally seal the radially expanded intermediate portion 300d of the tubular member 300 with the wellbore casing 305. In several alternative embodiments, the sealing member 300g includes one or more rigid anchors for engaging the wellbore casing 305 to thereby anchor the radially expanded and plastically deformed intermediate portion 300d of the tubular member 300 to the wellbore casing.

25791.292

**[0085]** In an exemplary embodiment, the intermediate portion 300d of the tubular member 300 includes one or more radial passages, slots, or perforations that are covered by the sealing member 300g. In an exemplary embodiment, the intermediate portion 300d of the tubular member 300 includes one or more radial passages, slots, or perforations that are not covered by the sealing member 300g.

**[0086]** Referring to Figs. 4, and 5a to 5d, in an exemplary embodiment, the tubular member 300 is formed by a process 400 that includes the steps of: (1) upsetting both ends of a tubular member in step 405; (2) expanding both upset ends of the tubular member in step 410; (3) stress relieving both expanded upset ends of the tubular member in step 415; (4) forming threaded connections in both expanded upset ends of the tubular member in step 420; and (5) putting a sealing material on the outside diameter of the non-expanded intermediate portion of the tubular member in step 425.

**[0087]** As illustrated in FIG. 5a, in step 405, both ends, 500a and 500b, of a tubular member 500 are upset using conventional upsetting methods. The upset ends, 500a and 500b, of the tubular member 500 include the wall thicknesses  $t_1$  and  $t_2$ . The intermediate portion 500c of the tubular member 500 includes the wall thickness  $t_{INT}$  and the interior diameter  $D_{INT}$ . In an exemplary embodiment, the wall thicknesses  $t_1$  and  $t_2$  are substantially equal in order to provide burst strength that is substantially equal along the entire length of the tubular member 500. In an exemplary embodiment, the wall thicknesses  $t_1$  and  $t_2$  are both greater than the wall thickness  $t_{INT}$  in order to provide burst strength that is substantially equal along the entire length of the tubular member 500, and also to optimally facilitate the formation of threaded connections in the first and second ends, 500a and 500b.

**[0088]** As illustrated in Fig. 5b, in steps 410 and 415, both ends, 500a and 500b, of the tubular member 500 are radially expanded using conventional radial expansion methods, and then both ends, 500a and 500b, of the tubular member are stress relieved. The radially expanded ends, 500a and 500b, of the tubular member 500 include the interior diameters  $D_1$  and  $D_2$ . In an exemplary embodiment, the interior diameters  $D_1$  and  $D_2$  are substantially equal in order to provide a burst strength that is substantially equal. In an exemplary embodiment, the ratio of the interior diameters  $D_1$  and  $D_2$  to the interior diameter  $D_{INT}$  ranges from about 100% to 120% in order to facilitate the subsequent radial expansion of the tubular member 500.

25791.292

**[0089]** In a preferred embodiment, the relationship between the wall thicknesses  $t_1$ ,  $t_2$ , and  $t_{INT}$  of the tubular member 500; the inside diameters  $D_1$ ,  $D_2$  and  $D_{INT}$  of the tubular member 500; the inside diameter  $D_{wellbore}$  of the wellbore casing, or other structure, that the tubular member 500 will be inserted into; and the outside diameter  $D_{cone}$  of the expansion cone that will be used to radially expand the tubular member 500 within the wellbore casing is given by the following expression:

$$D_{wellbore} - 2 * t_1 \geq D_1 \geq \frac{1}{t_1} [(t_1 - t_{INT}) * D_{cone} + t_{INT} * D_{INT}] \quad (1)$$

where  $t_1 = t_2$ ; and

$$D_1 = D_2.$$

**[0090]** By satisfying the relationship given in equation (1), the expansion forces placed upon the tubular member 500 during the subsequent radial expansion process are substantially equalized. More generally, the relationship given in equation (1) may be used to calculate the optimal geometry for the tubular member 500 for subsequent radial expansion and plastic deformation of the tubular member 500 for fabricating and/or repairing a wellbore casing, a pipeline, or a structural support.

**[0091]** As illustrated in FIG. 5c, in step 420, conventional threaded connections, 500d and 500e, are formed in both expanded ends, 500a and 500b, of the tubular member 500. In an exemplary embodiment, the threaded connections, 500d and 500e, are provided using conventional processes for forming pin and box type threaded connections available from Atlas-Bradford.

**[0092]** As illustrated in Fig. 5d, in step 425, a sealing member 500f is then applied onto the outside diameter of the non-expanded intermediate portion 500c of the tubular member 500. The sealing member 500f may be applied to the outside diameter of the non-expanded intermediate portion 500c of the tubular member 500 using any number of conventional commercially available methods. In a preferred embodiment, the sealing member 500f is applied to the outside diameter of the intermediate portion 500c of the tubular member 500 using commercially available chemical and temperature resistant adhesive bonding.

25791.292

**[0093]** In an exemplary embodiment, the expandable tubular members, 206, 214, and 220, of the system 200 are substantially identical to, and/or incorporate one or more of the teachings of, the tubular members 300 and 500.

**[0094]** Referring to Fig. 6, an exemplary embodiment of tubular expansion cone 600 for radially expanding the tubular members 206, 214, 220, 300 and 500 will now be described. The expansion cone 600 defines a passage 600a and includes a front end 605, a rear end 610, and a radial expansion section 615.

**[0095]** In an exemplary embodiment, the radial expansion section 615 includes a first conical outer surface 620 and a second conical outer surface 625. The first conical outer surface 620 includes an angle of attack  $\alpha_1$  and the second conical outer surface 625 includes an angle of attack  $\alpha_2$ . In an exemplary embodiment, the angle of attack  $\alpha_1$  is greater than the angle of attack  $\alpha_2$ . In this manner, the first conical outer surface 620 optimally radially expands the intermediate portions, 206c, 214c, 220c, 300d, and 500c, of the tubular members, 206, 214, 220, 300, and 500, and the second conical outer surface 525 optimally radially expands the pre-expanded first and second ends, 206a and 206d, 214a and 214d, 220a and 220d, 300b and 300f, and 500a and 500b, of the tubular members, 206, 214, 220, 300 and 500. In an exemplary embodiment, the first conical outer surface 620 includes an angle of attack  $\alpha_1$  ranging from about 8 to 20 degrees, and the second conical outer surface 625 includes an angle of attack  $\alpha_2$  ranging from about 4 to 15 degrees in order to optimally radially expand and plastically deform the tubular members, 206, 214, 220, 300 and 500. More generally, the expansion cone 600 may include 3 or more adjacent conical outer surfaces having angles of attack that decrease from the front end 605 of the expansion cone 600 to the rear end 610 of the expansion cone 600.

**[0096]** Referring to Fig. 7, another exemplary embodiment of a tubular expansion cone 700 defines a passage 700a and includes a front end 705, a rear end 710, and a radial expansion section 715. In an exemplary embodiment, the radial expansion section 715 includes an outer surface having a substantially parabolic outer profile thereby providing a paraboloid shape. In this manner, the outer surface of the radial expansion section 715 provides an angle of attack that constantly decreases from a maximum at the front end 705 of the expansion cone 700 to a minimum at the rear end 710 of the expansion cone. The parabolic outer profile of the outer surface of the radial expansion section 715 may be formed using

25791.292

a plurality of adjacent discrete conical sections and/or using a continuous curved surface. In this manner, the region of the outer surface of the radial expansion section 715 adjacent to the front end 705 of the expansion cone 700 may optimally radially expand the intermediate portions, 206c, 214c, 220c, 300d, and 500c, of the tubular members, 206, 214, 220, 300, and 500, while the region of the outer surface of the radial expansion section 715 adjacent to the rear end 710 of the expansion cone 700 may optimally radially expand the pre-expanded first and second ends, 206a and 206d, 214a and 214d, 220a and 220d, 300b and 300f, and 500a and 500b, of the tubular members, 206, 214, 220, 300 and 500. In an exemplary embodiment, the parabolic profile of the outer surface of the radial expansion section 715 is selected to provide an angle of attack that ranges from about 8 to 20 degrees in the vicinity of the front end 705 of the expansion cone 700 and an angle of attack in the vicinity of the rear end 710 of the expansion cone 700 from about 4 to 15 degrees.

**[0097]** In an exemplary embodiment, the tubular expansion cone 204 of the system 200 is substantially identical to the expansion cones 600 or 700, and/or incorporates one or more of the teachings of the expansion cones 600 and/or 700.

**[0098]** In several alternative embodiments, the teachings of the apparatus 130, the system 200, the expandable tubular member 300, the method 400, and/or the expandable tubular member 500 are at least partially combined.

Referring to Figs. 8a and 8b, in an exemplary embodiment, one or more of the slotted tubular members 145, 210, 212, 216, 218, and 300d include slotted tubular assemblies 800 that include a slotted tubular 802 that defines one or more radial passages 802a-802l and an elastic tubular sealing member 804 that is coupled to the slotted tubular 802. In an exemplary embodiment, the elastic tubular sealing member 804 is coupled to the exterior surface of the slotted tubular 802 and covers one or more of the radial passages 802a-802l. In this manner, the flow of fluidic materials through the covered radial passages of the slotted tubular 802 may be prevented by the elastic tubular sealing member 804 prior to and/or after the radial expansion and plastic deformation of the slotted tubular 802 within a wellbore 806. Alternatively, the elastic tubular sealing member 804 may be coupled to the interior surface of the slotted tubular member 802.

**[0100]** In an exemplary embodiment, the elastic tubular sealing member 804 comprises a swellable elastomeric material that swells in the presence of a fluidic

25791.292

material such as, for example, water. In this manner, as illustrated in Fig. 8b, the elastic tubular sealing member 804, either before or after radial expansion of the slotted tubular 802, will swell and expand radially into sealing contact with the interior surface of the wellbore 806. In this manner, the annulus between the slotted tubular 802 and the wellbore 806 may be fluidically sealed off. In several exemplary embodiments, the elastic tubular sealing member 804 is fabricated from conventional commercially available swellable elastomeric materials such as, for example, the swellable elastomeric materials commercially available from Ruma Rubber B.V. in the Netherlands and/or the Aquaprene™ swellable elastomeric products available from Sanyo Chemical Industries, Ltd. in Japan. In several exemplary embodiments, the composition of the swellable elastomeric material is provided substantially as disclosed in U.S. 4,590,227, the disclosure of which is incorporated herein by reference.

**[0101]** In several alternative embodiments, the slotted tubular members 145, 210, 212, 216, 218, 300d, and 802 include radial passages that permit fluidic materials to pass therethrough of any number of geometric shapes including, for example, circular holes and/or slotted holes and/or serpentine openings and/or irregularly shaped holes.

**[0102]** In several alternative embodiments, one or more of the sealing members 140, 206e, 214e, 220e, and 300g are fabricated from swellable elastomeric materials in order to provide sealing engagement with the wellbores 105 and/or 224.

**[0103]** An apparatus has been described that includes a zonal isolation assembly including one or more solid tubular members, each solid tubular member including one or more external seals, and one or more perforated tubular members coupled to the solid tubular members, and a shoe coupled to the zonal isolation assembly. In an exemplary embodiment, the zonal isolation assembly further includes one or more intermediate solid tubular members coupled to and interleaved among the perforated tubular members, each intermediate solid tubular member including one or more external seals. In an exemplary embodiment, the zonal isolation assembly further includes one or more valve members for controlling the flow of fluidic materials between the tubular members. In an exemplary embodiment, one or more of the intermediate solid tubular members include one or more valve members.

25791.292

**[0104]** An apparatus has also been described that includes a zonal isolation assembly that includes one or more primary solid tubulars, each primary solid tubular including one or more external annular seals,  $n$  perforated tubulars coupled to the primary solid tubulars, and  $n-1$  intermediate solid tubulars coupled to and interleaved among the perforated tubulars, each intermediate solid tubular including one or more external annular seals, and a shoe coupled to the zonal isolation assembly.

**[0105]** A method of isolating a first subterranean zone from a second subterranean zone in a wellbore has also been described that includes positioning one or more primary solid tubulars within the wellbore, the primary solid tubulars traversing the first subterranean zone, positioning one or more perforated tubulars within the wellbore, the perforated tubulars traversing the second subterranean zone, fluidically coupling the perforated tubulars and the primary solid tubulars, and preventing the passage of fluids from the first subterranean zone to the second subterranean zone within the wellbore external to the solid and perforated tubulars.

**[0106]** A method of extracting materials from a producing subterranean zone in a wellbore, at least a portion of the wellbore including a casing, has also been described that includes positioning one or more primary solid tubulars within the wellbore, fluidically coupling the primary solid tubulars with the casing, positioning one or more perforated tubulars within the wellbore, the perforated tubulars traversing the producing subterranean zone, fluidically coupling the perforated tubulars with the primary solid tubulars, fluidically isolating the producing subterranean zone from at least one other subterranean zone within the wellbore, and fluidically coupling at least one of the perforated tubulars with the producing subterranean zone. In an exemplary embodiment, the method further includes controllably fluidically decoupling at least one of the perforated tubulars from at least one other of the perforated tubulars.

**[0107]** An apparatus has also been described that includes a subterranean formation including a wellbore, a zonal isolation assembly at least partially positioned within the wellbore that includes one or more solid tubular members, each solid tubular member including one or more external seals, and one or more perforated tubular members coupled to the solid tubular members, and a shoe positioned within the wellbore coupled to the zonal isolation assembly, wherein at least one of the solid tubular members and the perforated tubular members are

25791.292

formed by a radial expansion process performed within the wellbore. In an exemplary embodiment, the zonal isolation assembly further includes one or more intermediate solid tubular members coupled to and interleaved among the perforated tubular members, each intermediate solid tubular member including one or more external seals, wherein at least one of the solid tubular members, the perforated tubular members, and the intermediate solid tubular members are formed by a radial expansion process performed within the wellbore. In an exemplary embodiment, the zonal isolation assembly further comprises one or more valve members for controlling the flow of fluids between the solid tubular members and the perforated tubular members. In an exemplary embodiment, one or more of the intermediate solid tubular members include one or more valve members for controlling the flow of fluids between the solid tubular members and the perforated tubular members.

**[0108]** An apparatus has also been described that includes a subterranean formation including a wellbore, a zonal isolation assembly positioned within the wellbore that includes one or more primary solid tubulars, each primary solid tubular including one or more external annular seals,  $n$  perforated tubulars positioned coupled to the primary solid tubulars, and  $n-1$  intermediate solid tubulars coupled to and interleaved among the perforated tubulars, each intermediate solid tubular including one or more external annular seals, and a shoe coupled to the zonal isolation assembly, wherein at least one of the primary solid tubulars, the perforated tubulars, and the intermediate solid tubulars are formed by a radial expansion process performed within the wellbore.

**[0109]** A method of isolating a first subterranean zone from a second subterranean zone in a wellbore has also been described that includes positioning one or more primary solid tubulars within the wellbore, the primary solid tubulars traversing the first subterranean zone, positioning one or more perforated tubulars within the wellbore, the perforated tubulars traversing the second subterranean zone, radially expanding at least one of the primary solid tubulars and perforated tubulars within the wellbore, fluidically coupling the perforated tubulars and the primary solid tubulars, and preventing the passage of fluids from the first subterranean zone to the second subterranean zone within the wellbore external to the primary solid tubulars and perforated tubulars.

25791.292

**[0110]** A method of extracting materials from a producing subterranean zone in a wellbore, at least a portion of the wellbore including a casing, has also been described that includes positioning one or more primary solid tubulars within the wellbore, positioning one or more perforated tubulars within the wellbore, the perforated tubulars traversing the producing subterranean zone, radially expanding at least one of the primary solid tubulars and the perforated tubulars within the wellbore, fluidicly coupling the primary solid tubulars with the casing, fluidicly coupling the perforated tubulars with the primary solid tubulars, fluidicly isolating the producing subterranean zone from at least one other subterranean zone within the wellbore, and fluidicly coupling at least one of the perforated tubulars with the producing subterranean zone. In an exemplary embodiment, the method further includes controllably fluidicly decoupling at least one of the perforated tubulars from at least one other of the perforated tubulars.

**[0111]** An apparatus has also been described that includes a subterranean formation including a wellbore, a zonal isolation assembly positioned within the wellbore that includes  $n$  solid tubular members positioned within the wellbore, each solid tubular member including one or more external seals, and  $n-1$  perforated tubular members positioned within the wellbore coupled to and interleaved among the solid tubular members, and a shoe positioned within the wellbore coupled to the zonal isolation assembly. In an exemplary embodiment, the zonal isolation assembly further comprises one or more valve members for controlling the flow of fluids between the solid tubular members and the perforated tubular members. In an exemplary embodiment, one or more of the solid tubular members include one or more valve members for controlling the flow of fluids between the solid tubular members and the perforated tubular members.

**[0112]** A system for isolating a first subterranean zone from a second subterranean zone in a wellbore has also been described that includes means for positioning one or more primary solid tubulars within the wellbore, the primary solid tubulars traversing the first subterranean zone, means for positioning one or more perforated tubulars within the wellbore, the perforated tubulars traversing the second subterranean zone, means for fluidicly coupling the perforated tubulars and the primary solid tubulars, and means for preventing the passage of fluids from the first subterranean zone to the second subterranean zone within the wellbore external to the primary solid tubulars and the perforated tubulars.

25791.292

**[0113]** A system for extracting materials from a producing subterranean zone in a wellbore, at least a portion of the wellbore including a casing, has also been described that includes means for positioning one or more primary solid tubulars within the wellbore, means for fluidically coupling the primary solid tubulars with the casing, means for positioning one or more perforated tubulars within the wellbore, the perforated tubulars traversing the producing subterranean zone, means for fluidically coupling the perforated tubulars with the primary solid tubulars, means for fluidically isolating the producing subterranean zone from at least one other subterranean zone within the wellbore, and means for fluidically coupling at least one of the perforated tubulars with the producing subterranean zone. In an exemplary embodiment, the system further includes means for controllably fluidically decoupling at least one of the perforated tubulars from at least one other of the perforated tubulars.

**[0114]** A system for isolating a first subterranean zone from a second subterranean zone in a wellbore has also been described that includes means for positioning one or more primary solid tubulars within the wellbore, the primary solid tubulars traversing the first subterranean zone, means for positioning one or more perforated tubulars within the wellbore, the perforated tubulars traversing the second subterranean zone, means for radially expanding at least one of the primary solid tubulars and perforated tubulars within the wellbore, means for fluidically coupling the perforated tubulars and the primary solid tubulars, and means for preventing the passage of fluids from the first subterranean zone to the second subterranean zone within the wellbore external to the primary solid tubulars and perforated tubulars.

**[0115]** A system for extracting materials from a producing subterranean zone in a wellbore, at least a portion of the wellbore including a casing, has also been described that includes means for positioning one or more primary solid tubulars within the wellbore, means for positioning one or more perforated tubulars within the wellbore, the perforated tubulars traversing the producing subterranean zone, means for radially expanding at least one of the primary solid tubulars and the perforated tubulars within the wellbore, means for fluidically coupling the primary solid tubulars with the casing, means for fluidically coupling the perforated tubulars with the solid tubulars, means for fluidically isolating the producing subterranean zone from at least one other subterranean zone within the wellbore, and means for

25791.292

fluidicly coupling at least one of the perforated tubulars with the producing subterranean zone. In an exemplary embodiment, the system further includes means for controllably fluidicly decoupling at least one of the perforated tubulars from at least one other of the perforated tubulars.

**[0116]** A system for isolating subterranean zones traversed by a wellbore has also been described that includes a tubular support member defining a first passage, a tubular expansion cone defining a second passage fluidicly coupled to the first passage coupled to an end of the tubular support member and comprising a tapered end, a tubular liner coupled to and supported by the tapered end of the tubular expansion cone, and a shoe defining a valveable passage coupled to an end of the tubular liner, wherein the tubular liner includes one or more expandable tubular members that each include a tubular body comprising an intermediate portion and first and second expanded end portions coupled to opposing ends of the intermediate portion, and a sealing member coupled to the exterior surface of the intermediate portion, and one or more slotted tubular members coupled to the expandable tubular members, wherein the inside diameters of the other tubular members are greater than or equal to the outside diameter of the tubular expansion cone. In an exemplary embodiment, the wall thicknesses of the first and second expanded end portions are greater than the wall thickness of the intermediate portion. In an exemplary embodiment, each expandable tubular member further includes a first tubular transitional member coupled between the first expanded end portion and the intermediate portion, and a second tubular transitional member coupled between the second expanded end portion and the intermediate portion, wherein the angles of inclination of the first and second tubular transitional members relative to the intermediate portion ranges from about 0 to 30 degrees. In an exemplary embodiment, the outside diameter of the intermediate portion ranges from about 75 percent to about 98 percent of the outside diameters of the first and second expanded end portions. In an exemplary embodiment, the burst strength of the first and second expanded end portions is substantially equal to the burst strength of the intermediate tubular section. In an exemplary embodiment, the ratio of the inside diameters of the first and second expanded end portions to the interior diameter of the intermediate portion ranges from about 100 to 120 percent. In an exemplary embodiment, the relationship between the wall thicknesses  $t_1$ ,  $t_2$ , and  $t_{INT}$  of the first expanded end portion, the second expanded

25791.292

end portion, and the intermediate portion, respectively, of the expandable tubular members, the inside diameters  $D_1$ ,  $D_2$  and  $D_{INT}$  of the first expanded end portion, the second expanded end portion, and the intermediate portion, respectively, of the expandable tubular members, and the inside diameter  $D_{wellbore}$  of the wellbore casing that the expandable tubular member will be inserted into, and the outside diameter  $D_{cone}$  of the expansion cone that will be used to radially expand the expandable tubular member within the wellbore is given by the following expression:

$$D_{wellbore} - 2 * t_1 \geq D_1 \geq \frac{1}{t_1} [(t_1 - t_{INT}) * D_{cone} + t_{INT} * D_{INT}];$$

wherein  $t_1 = t_2$ ; and wherein  $D_1 = D_2$ .

**[0117]** In an exemplary embodiment, the tapered end of the tubular expansion cone includes a plurality of adjacent discrete tapered sections. In an exemplary embodiment, the angle of attack of the adjacent discrete tapered sections increases in a continuous manner from one end of the tubular expansion cone to the opposite end of the tubular expansion cone. In an exemplary embodiment, the tapered end of the tubular expansion cone includes a paraboloid body. In an exemplary embodiment, the angle of attack of the outer surface of the paraboloid body increases in a continuous manner from one end of the paraboloid body to the opposite end of the paraboloid body. In an exemplary embodiment, the tubular liner comprises a plurality of expandable tubular members; and wherein the other tubular members are interleaved among the expandable tubular members.

**[0118]** A method of isolating subterranean zones traversed by a wellbore has also been described that includes positioning a tubular liner within the wellbore, and radially expanding one or more discrete portions of the tubular liner into engagement with the wellbore. In an exemplary embodiment, a plurality of discrete portions of the tubular liner are radially expanded into engagement with the wellbore. In an exemplary embodiment, the remaining portions of the tubular liner are not radially expanded. In an exemplary embodiment, one of the discrete portions of the tubular liner is radially expanded by injecting a fluidic material into the tubular liner; and wherein the remaining ones of the discrete portions of the

25791.292

tubular liner are radially expanded by pulling an expansion cone through the remaining ones of the discrete portions of the tubular liner. In an exemplary embodiment, the tubular liner comprises a plurality of tubular members; and wherein one or more of the tubular members are radially expanded into engagement with the wellbore and one or more of the tubular members are not radially expanded into engagement with the wellbore. In an exemplary embodiment, the tubular members that are radially expanded into engagement with the wellbore comprise a portion that is radially expanded into engagement with the wellbore and a portion that is not radially expanded into engagement with the wellbore. In an exemplary embodiment, the tubular liner includes one or more expandable tubular members that each include a tubular body comprising an intermediate portion and first and second expanded end portions coupled to opposing ends of the intermediate portion, and a sealing member coupled to the exterior surface of the intermediate portion, and one or more slotted tubular members coupled to the expandable tubular members, wherein the inside diameters of the slotted tubular members are greater than or equal to the maximum inside diameters of the expandable tubular members. In an exemplary embodiment, the tubular liner includes a plurality of expandable tubular members; and wherein the slotted tubular members are interleaved among the expandable tubular members.

**[0119]** A system for isolating subterranean zones traversed by a wellbore has also been described that includes means for positioning a tubular liner within the wellbore, and means for radially expanding one or more discrete portions of the tubular liner into engagement with the wellbore. In an exemplary embodiment, a plurality of discrete portions of the tubular liner are radially expanded into engagement with the wellbore. In an exemplary embodiment, the remaining portions of the tubular liner are not radially expanded. In an exemplary embodiment, one discrete portion of the tubular liner is radially expanded by injecting a fluidic material into the tubular liner; and wherein the other discrete portions of the tubular liner are radially expanded by pulling an expansion cone through the other discrete portions of the tubular liner. In an exemplary embodiment, the tubular liner includes a plurality of tubular members; and wherein one or more of the tubular members are radially expanded into engagement with the wellbore and one or more of the tubular members are not radially expanded into

25791.292

engagement with the wellbore. In an exemplary embodiment, the tubular members that are radially expanded into engagement with the wellbore include a portion that is radially expanded into engagement with the wellbore and a portion that is not radially expanded into engagement with the wellbore.

**[0120]** An apparatus for isolating subterranean zones has also been described that includes a subterranean formation defining a borehole, and a tubular liner positioned in and coupled to the borehole at one or more discrete locations. In an exemplary embodiment, the tubular liner is coupled to the borehole at a plurality of discrete locations. In an exemplary embodiment, the tubular liner is coupled to the borehole by a process that includes positioning the tubular liner within the borehole, and radially expanding one or more discrete portions of the tubular liner into engagement with the borehole. In an exemplary embodiment, a plurality of discrete portions of the tubular liner are radially expanded into engagement with the borehole. In an exemplary embodiment, the remaining portions of the tubular liner are not radially expanded. In an exemplary embodiment, one of the discrete portions of the tubular liner is radially expanded by injecting a fluidic material into the tubular liner; and wherein the other discrete portions of the tubular liner are radially expanded by pulling an expansion cone through the other discrete portions of the tubular liner. In an exemplary embodiment, the tubular liner comprises a plurality of tubular members; and wherein one or more of the tubular members are radially expanded into engagement with the borehole and one or more of the tubular members are not radially expanded into engagement with the borehole. In an exemplary embodiment, the tubular members that are radially expanded into engagement with the borehole include a portion that is radially expanded into engagement with the borehole and a portion that is not radially expanded into engagement with the borehole. In an exemplary embodiment, prior to the radial expansion the tubular liner includes one or more expandable tubular members that each include a tubular body comprising an intermediate portion and first and second expanded end portions coupled to opposing ends of the intermediate portion, and a sealing member coupled to the exterior surface of the intermediate portion, and one or more slotted tubular members coupled to the expandable tubular members, wherein the inside diameters of the slotted tubular members are greater than or equal to the maximum inside diameters of the expandable tubular members. In an exemplary embodiment, the tubular liner includes a plurality of

25791.292

expandable tubular members; and wherein the slotted tubular members are interleaved among the expandable tubular members.

**[0121]** An apparatus has been described that includes a zonal isolation assembly including one or more solid tubular members, each solid tubular member including one or more external seals, and one or more perforated tubular members coupled to the solid tubular members, and a shoe coupled to the zonal isolation assembly. One or more of the perforated tubular members include an elastic sealing member coupled to the perforated tubular member and covering one or more of the perforations of the perforated tubular member. In an exemplary embodiment, the elastic sealing member comprises a tubular elastic sealing member. In an exemplary embodiment, the elastic sealing member comprises a swellable elastomeric sealing member that swells in the presence of fluidic materials. In an exemplary embodiment, one or more of the external seals comprise a swellable elastomeric sealing member that swells in the presence of fluidic materials. In an exemplary embodiment, the zonal isolation assembly further includes one or more intermediate solid tubular members coupled to and interleaved among the perforated tubular members, each intermediate solid tubular member including one or more external seals. In an exemplary embodiment, the zonal isolation assembly further includes one or more valve members for controlling the flow of fluidic materials between the tubular members. In an exemplary embodiment, one or more of the intermediate solid tubular members include one or more valve members.

**[0122]** An apparatus has been described that includes a zonal isolation assembly including one or more primary solid tubulars, each primary solid tubular including one or more external seals,  $n$  perforated tubulars coupled to the primary solid tubulars, and  $n-1$  intermediate solid tubulars coupled to and interleaved among the perforated tubulars, each intermediate solid tubular including one or more external seals, and a shoe coupled to the zonal isolation assembly. One or more of the perforated tubular members include an elastic sealing member coupled to the perforated tubular member and covering one or more of the perforations of the perforated tubular member. In an exemplary embodiment, the elastic sealing member comprises a swellable elastomeric sealing member that swells in the presence of fluidic materials. In an exemplary embodiment, one or more of the

25791.292

external seals comprise a swellable elastomeric sealing member that swells in the presence of fluidic materials.

**[0123]** A method of isolating a first subterranean zone from a second subterranean zone in a wellbore has been described that includes positioning one or more primary solid tubulars within the wellbore, the primary solid tubulars traversing the first subterranean zone, positioning one or more perforated tubulars within the wellbore, the perforated tubulars traversing the second subterranean zone, fluidically coupling the perforated tubulars and the primary solid tubulars, preventing the passage of fluids from the first subterranean zone to the second subterranean zone within the wellbore external to the solid and perforated tubulars, and covering one or more of the perforations of one or more of the perforated tubular members using an elastic sealing member. In an exemplary embodiment, the elastic sealing member comprises a swellable elastomeric sealing member that swells in the presence of fluidic materials.

**[0124]** A method of extracting materials from a producing subterranean zone in a wellbore, at least a portion of the wellbore including a casing, has been described that includes positioning one or more primary solid tubulars within the wellbore, fluidically coupling the primary solid tubulars with the casing, positioning one or more perforated tubulars within the wellbore, the perforated tubulars traversing the producing subterranean zone, fluidically coupling the perforated tubulars with the primary solid tubulars, fluidically isolating the producing subterranean zone from at least one other subterranean zone within the wellbore, fluidically coupling at least one of the perforated tubulars with the producing subterranean zone, and covering one or more of the perforations of one or more of the perforated tubular members using an elastic sealing member. In an exemplary embodiment, the elastic sealing member comprises a swellable elastomeric sealing member that swells in the presence of fluidic materials. In an exemplary embodiment, the method further includes controllably fluidically decoupling at least one of the perforated tubulars from at least one other of the perforated tubulars.

**[0125]** An apparatus has been described that includes a subterranean formation including a wellbore, that includes a zonal isolation assembly at least partially positioned within the wellbore including one or more solid tubular members, each solid tubular member including one or more external seals, and one or more perforated tubular members coupled to the solid tubular members, and a shoe

25791.292

positioned within the wellbore coupled to the zonal isolation assembly. At least one of the solid tubular members and the perforated tubular members are formed by a radial expansion process performed within the wellbore, and one or more of the perforated tubular members include an elastic sealing member coupled to the perforated tubular member and covering one or more of the perforations of the perforated tubular member. In an exemplary embodiment, the elastic sealing member comprises a swellable elastomeric sealing member that swells in the presence of fluidic materials. In an exemplary embodiment, one or more of the external seals comprise a swellable elastomeric sealing member that swells in the presence of fluidic materials. In an exemplary embodiment, the zonal isolation assembly further includes one or more intermediate solid tubular members coupled to and interleaved among the perforated tubular members, each intermediate solid tubular member including one or more external seals, wherein at least one of the solid tubular members, the perforated tubular members, and the intermediate solid tubular members are formed by a radial expansion process performed within the wellbore. In an exemplary embodiment, the zonal isolation assembly further includes one or more valve members for controlling the flow of fluids between the solid tubular members and the perforated tubular members. In an exemplary embodiment, one or more of the intermediate solid tubular members include one or more valve members for controlling the flow of fluids between the solid tubular members and the perforated tubular members.

**[0126]** An apparatus has been described that includes a subterranean formation including a wellbore, a zonal isolation assembly positioned within the wellbore including one or more primary solid tubulars, each primary solid tubular including one or more external seals,  $n$  perforated tubulars positioned coupled to the primary solid tubulars, and  $n-1$  intermediate solid tubulars coupled to and interleaved among the perforated tubulars, each intermediate solid tubular including one or more external seals, and a shoe coupled to the zonal isolation assembly. At least one of the primary solid tubulars, the perforated tubulars, and the intermediate solid tubulars are formed by a radial expansion process performed within the wellbore, and one or more of the perforated tubular members include an elastic sealing member coupled to the perforated tubular member and covering one or more of the perforations of the perforated tubular member. In an exemplary embodiment, the elastic sealing member comprises a swellable elastomeric sealing member that

25791.292

swells in the presence of fluidic materials. In an exemplary embodiment, one or more of the external seals comprise a swellable elastomeric sealing member that swells in the presence of fluidic materials.

**[0127]** A method of isolating a first subterranean zone from a second subterranean zone in a wellbore has been described that includes positioning one or more primary solid tubulars within the wellbore, the primary solid tubulars traversing the first subterranean zone, positioning one or more perforated tubulars within the wellbore, the perforated tubulars traversing the second subterranean zone, radially expanding at least one of the primary solid tubulars and perforated tubulars within the wellbore, fluidically coupling the perforated tubulars and the primary solid tubulars, preventing the passage of fluids from the first subterranean zone to the second subterranean zone within the wellbore external to the primary solid tubulars and perforated tubulars, and covering one or more of the perforations of one or more of the perforated tubular members using an elastic sealing member. In an exemplary embodiment, the elastic sealing member comprises a swellable elastomeric sealing member that swells in the presence of fluidic materials.

**[0128]** A method of extracting materials from a producing subterranean zone in a wellbore, at least a portion of the wellbore including a casing, has been described that includes positioning one or more primary solid tubulars within the wellbore, positioning one or more perforated tubulars within the wellbore, the perforated tubulars traversing the producing subterranean zone, radially expanding at least one of the primary solid tubulars and the perforated tubulars within the wellbore, fluidically coupling the primary solid tubulars with the casing, fluidically coupling the perforated tubulars with the primary solid tubulars, fluidically isolating the producing subterranean zone from at least one other subterranean zone within the wellbore, fluidically coupling at least one of the perforated tubulars with the producing subterranean zone, and covering one or more of the perforations of one or more of the perforated tubular members using an elastic sealing member. In an exemplary embodiment, the elastic sealing member comprises a swellable elastomeric sealing member that swells in the presence of fluidic materials. In an exemplary embodiment, the method further includes controllably fluidically decoupling at least one of the perforated tubulars from at least one other of the perforated tubulars.

**[0129]** An apparatus has been described that includes a subterranean formation including a wellbore, a zonal isolation assembly positioned within the wellbore

25791.292

including: n solid tubular members positioned within the wellbore, each solid tubular member including one or more external seals, and n-1 perforated tubular members positioned within the wellbore coupled to and interleaved among the solid tubular members, and a shoe positioned within the wellbore coupled to the zonal isolation assembly. One or more of the perforated tubular members include a tubular elastic sealing member coupled to the perforated tubular member and covering one or more of the perforations of the perforated tubular member. In an exemplary embodiment, the elastic sealing member comprises a swellable elastomeric sealing member that swells in the presence of fluidic materials. In an exemplary embodiment, one or more of the external seals comprise a swellable elastomeric sealing member that swells in the presence of fluidic materials. In an exemplary embodiment, the zonal isolation assembly further comprises one or more valve members for controlling the flow of fluids between the solid tubular members and the perforated tubular members. In an exemplary embodiment, one or more of the solid tubular members include one or more valve members for controlling the flow of fluids between the solid tubular members and the perforated tubular members.

**[0130]** A system for isolating a first subterranean zone from a second subterranean zone in a wellbore has been described that includes means for positioning one or more primary solid tubulars within the wellbore, the primary solid tubulars traversing the first subterranean zone, means for positioning one or more perforated tubulars within the wellbore, the perforated tubulars traversing the second subterranean zone, means for fluidically coupling the perforated tubulars and the primary solid tubulars, means for preventing the passage of fluids from the first subterranean zone to the second subterranean zone within the wellbore external to the primary solid tubulars and the perforated tubulars, and means for sealing one or more of the perforations of one or more of the perforated tubular members.

**[0131]** A system for extracting materials from a producing subterranean zone in a wellbore, at least a portion of the wellbore including a casing, has been described that includes means for positioning one or more primary solid tubulars within the wellbore, means for fluidically coupling the primary solid tubulars with the casing, means for positioning one or more perforated tubulars within the wellbore, the perforated tubulars traversing the producing subterranean zone, means for fluidically coupling the perforated tubulars with the primary solid tubulars, means for fluidically isolating the producing subterranean zone from at least one other subterranean

25791.292

zone within the wellbore, means for fluidicly coupling at least one of the perforated tubulars with the producing subterranean zone, and means for sealing one or more of the perforations of one or more of the perforated tubular members using an elastic sealing member. In an exemplary embodiment, the system further includes means for controllably fluidicly decoupling at least one of the perforated tubulars from at least one other of the perforated tubulars.

**[0132]** A system for isolating a first subterranean zone from a second subterranean zone in a wellbore has been described that includes means for positioning one or more primary solid tubulars within the wellbore, the primary solid tubulars traversing the first subterranean zone, means for positioning one or more perforated tubulars within the wellbore, the perforated tubulars traversing the second subterranean zone, means for radially expanding at least one of the primary solid tubulars and perforated tubulars within the wellbore, means for fluidicly coupling the perforated tubulars and the primary solid tubulars, means for preventing the passage of fluids from the first subterranean zone to the second subterranean zone within the wellbore external to the primary solid tubulars and perforated tubulars, and means for sealing one or more of the perforations of one or more of the perforated tubular members using an elastic sealing member.

**[0133]** A system for extracting materials from a producing subterranean zone in a wellbore, at least a portion of the wellbore including a casing, has been described that includes means for positioning one or more primary solid tubulars within the wellbore, means for positioning one or more perforated tubulars within the wellbore, the perforated tubulars traversing the producing subterranean zone, means for radially expanding at least one of the primary solid tubulars and the perforated tubulars within the wellbore, means for fluidicly coupling the primary solid tubulars with the casing, means for fluidicly coupling the perforated tubulars with the solid tubulars, means for fluidicly isolating the producing subterranean zone from at least one other subterranean zone within the wellbore, means for fluidicly coupling at least one of the perforated tubulars with the producing subterranean zone, and means for sealing one or more of the perforations of one or more of the perforated tubular members using an elastic sealing member. In an exemplary embodiment, the system further includes means for controllably fluidicly decoupling at least one of the perforated tubulars from at least one other of the perforated tubulars.

25791.292

**[0134]** A system for isolating subterranean zones traversed by a wellbore has been described that includes a tubular support member defining a first passage, a tubular expansion cone defining a second passage fluidically coupled to the first passage coupled to an end of the tubular support member and including a tapered end, a tubular liner coupled to and supported by the tapered end of the tubular expansion cone, and a shoe defining a valveable passage coupled to an end of the tubular liner. The tubular liner includes one or more expandable tubular members that each include: a tubular body comprising an intermediate portion and first and second expanded end portions coupled to opposing ends of the intermediate portion, and a sealing member coupled to the exterior surface of the intermediate portion, and one or more perforated tubular members coupled to the expandable tubular members. The inside diameters of the perforated tubular members are greater than or equal to the outside diameter of the tubular expansion cone. In an exemplary embodiment, the wall thicknesses of the first and second expanded end portions are greater than the wall thickness of the intermediate portion. In an exemplary embodiment, each expandable tubular member further includes: a first tubular transitional member coupled between the first expanded end portion and the intermediate portion, and a second tubular transitional member coupled between the second expanded end portion and the intermediate portion. The angles of inclination of the first and second tubular transitional members relative to the intermediate portion ranges from about 0 to 30 degrees. In an exemplary embodiment, the outside diameter of the intermediate portion ranges from about 75 percent to about 98 percent of the outside diameters of the first and second expanded end portions. In an exemplary embodiment, the burst strength of the first and second expanded end portions is substantially equal to the burst strength of the intermediate tubular section. In an exemplary embodiment, the ratio of the inside diameters of the first and second expanded end portions to the interior diameter of the intermediate portion ranges from about 100 to 120 percent. In an exemplary embodiment, the relationship between the wall thicknesses  $t_1$ ,  $t_2$ , and  $t_{INT}$  of the first expanded end portion, the second expanded end portion, and the intermediate portion, respectively, of the expandable tubular members, the inside diameters  $D_1$ ,  $D_2$  and  $D_{INT}$  of the first expanded end portion, the second expanded end portion, and the intermediate portion, respectively, of the expandable tubular members, and the inside diameter  $D_{wellbore}$  of the wellbore casing that the

25791.292

expandable tubular member will be inserted into, and the outside diameter  $D_{cone}$  of the expansion cone that will be used to radially expand the expandable tubular member within the wellbore is given by the following expression:

$$D_{wellbore} - 2 * t_1 \geq D_1 \geq \frac{1}{t_1} [(t_1 - t_{INT}) * D_{cone} + t_{INT} * D_{INT}]$$

wherein  $t_1 = t_2$ ; and wherein  $D_1 = D_2$ .

**[0135]** In an exemplary embodiment, the tapered end of the tubular expansion cone includes a plurality of adjacent discrete tapered sections. In an exemplary embodiment, the angle of attack of the adjacent discrete tapered sections increases in a continuous manner from one end of the tubular expansion cone to the opposite end of the tubular expansion cone. In an exemplary embodiment, the tapered end of the tubular expansion cone includes a paraboloid body. In an exemplary embodiment, the angle of attack of the outer surface of the paraboloid body increases in a continuous manner from one end of the paraboloid body to the opposite end of the paraboloid body. In an exemplary embodiment, the tubular liner includes a plurality of expandable tubular members, and the other tubular members are interleaved among the expandable tubular members. In an exemplary embodiment, one or more of the perforated tubular members include an elastic sealing member coupled to an exterior surface of the perforated tubular member and covering one or more of the perforations of the perforated tubular member.

**[0136]** A method of isolating subterranean zones traversed by a wellbore has been described that includes positioning a tubular liner within the wellbore, and radially expanding one or more discrete portions of the tubular liner into engagement with the wellbore. The tubular liner includes a plurality of tubular members; and wherein one or more of the tubular members are radially expanded into engagement with the wellbore and one or more of the tubular members are not radially expanded into engagement with the wellbore, and tubular liner includes one or more expandable tubular members that each include: a tubular body comprising an intermediate portion and first and second expanded end portions coupled to opposing ends of the intermediate portion, and a sealing member coupled to the

25791.292

exterior surface of the intermediate portion, and one or more perforated tubular members coupled to the expandable tubular members. The inside diameters of the perforated tubular members are greater than or equal to the maximum inside diameters of the expandable tubular members. In an exemplary embodiment, the tubular liner includes a plurality of expandable tubular members; and wherein the perforated tubular members are interleaved among the expandable tubular members. In an exemplary embodiment, one or more of the perforated tubular members include an elastic sealing member coupled to an exterior surface of the perforated tubular member and covering one or more of the perforations of the perforated tubular member.

**[0137]** An apparatus for isolating subterranean zones has been described that includes a subterranean formation defining a borehole, and a tubular liner positioned in and coupled to the borehole at one or more discrete locations. The tubular liner includes a plurality of tubular members; and one or more of the tubular members are radially expanded into engagement with the borehole and one or more of the tubular members are not radially expanded into engagement with the borehole. The tubular liner is coupled to the borehole by a process that includes positioning the tubular liner within the borehole, and radially expanding one or more discrete portions of the tubular liner into engagement with the borehole. In an exemplary embodiment, prior to the radial expansion the tubular liner includes one or more expandable tubular members that each include a tubular body comprising an intermediate portion and first and second expanded end portions coupled to opposing ends of the intermediate portion, and a sealing member coupled to the exterior surface of the intermediate portion, and one or more perforated tubular members coupled to the expandable tubular members. The inside diameters of the perforated tubular members are greater than or equal to the maximum inside diameters of the expandable tubular members. In an exemplary embodiment, the tubular liner includes a plurality of expandable tubular members, and the perforated tubular members are interleaved among the expandable tubular members. In an exemplary embodiment, one or more of the perforated tubular members include a tubular elastic sealing member coupled to an exterior surface of the perforated tubular member and covering one or more of the perforations of the perforated tubular member.

25791.292

**[0138]** A method of sealing an annulus between a wellbore and a tubular member positioned within the wellbore has been described that includes coupling a swellable elastomeric material to the exterior of the tubular member that swells in the presence of fluidic materials to sealingly engage the wellbore. In an exemplary embodiment, the method further includes radially expanding and plastically deforming the tubular member within the wellbore. In an exemplary embodiment, the tubular member defines one or more radial passages. In an exemplary embodiment, the swellable elastomeric materials covers and seals one or more of the radial passages of the tubular member.

**[0139]** In several alternative embodiments, the teachings of the present disclosure may be applied to, for example, oil and gas exploration and production and/or the extraction of geothermal energy from subterranean formations.

**[0140]** Although illustrative embodiments of the invention have been shown and described, a wide range of modification, changes and substitution is contemplated in the foregoing disclosure. In some instances, some features of the present invention may be employed without a corresponding use of the other features. Accordingly, it is appropriate that the appended claims be construed broadly and in a manner consistent with the scope of the invention.

25791.292

### Claims

What is claimed is:

1. An apparatus, comprising:  
a zonal isolation assembly comprising:  
one or more solid tubular members, each solid tubular member including one or more external seals; and  
one or more perforated tubular members coupled to the solid tubular members; and  
a shoe coupled to the zonal isolation assembly;  
wherein one or more of the perforated tubular members include an elastic sealing member coupled to the perforated tubular member and covering one or more of the perforations of the perforated tubular member.
2. The apparatus of claim 1, wherein the elastic sealing member comprises a tubular elastic sealing member.
3. The apparatus of claim 1, wherein the elastic sealing member comprises a swellable elastomeric sealing member that swells in the presence of fluidic materials.
4. The apparatus of claim 1, wherein one or more of the external seals comprise a swellable elastomeric sealing member that swells in the presence of fluidic materials.
5. The apparatus of claim 1, wherein the zonal isolation assembly further comprises:  
one or more intermediate solid tubular members coupled to and interleaved among the perforated tubular members, each intermediate solid tubular member including one or more external seals.

25791.292

6. The apparatus of claim 1, wherein the zonal isolation assembly further comprises one or more valve members for controlling the flow of fluidic materials between the tubular members.
7. The apparatus of claim 5, wherein one or more of the intermediate solid tubular members include one or more valve members.
8. An apparatus, comprising:  
a zonal isolation assembly comprising:
  - one or more primary solid tubulars, each primary solid tubular including one or more external seals;
  - n perforated tubulars coupled to the primary solid tubulars; and
  - n-1 intermediate solid tubulars coupled to and interleaved among the perforated tubulars, each intermediate solid tubular including one or more external seals; anda shoe coupled to the zonal isolation assembly;  
wherein one or more of the perforated tubular members include an elastic sealing member coupled to the perforated tubular member and covering one or more of the perforations of the perforated tubular member.
9. The apparatus of claim 8, wherein the elastic sealing member comprises a swellable elastomeric sealing member that swells in the presence of fluidic materials.
10. The apparatus of claim 8, wherein one or more of the external seals comprise a swellable elastomeric sealing member that swells in the presence of fluidic materials.
11. A method of isolating a first subterranean zone from a second subterranean zone in a wellbore, comprising:
  - positioning one or more primary solid tubulars within the wellbore, the primary solid tubulars traversing the first subterranean zone;

25791.292

positioning one or more perforated tubulars within the wellbore, the perforated tubulars traversing the second subterranean zone;  
fluidically coupling the perforated tubulars and the primary solid tubulars;  
preventing the passage of fluids from the first subterranean zone to the second subterranean zone within the wellbore external to the solid and perforated tubulars; and  
covering one or more of the perforations of one or more of the perforated tubular members using an elastic sealing member.

12. The method of claim 11, wherein the elastic sealing member comprises a swellable elastomeric sealing member that swells in the presence of fluidic materials.

13. A method of extracting materials from a producing subterranean zone in a wellbore, at least a portion of the wellbore including a casing, comprising;  
positioning one or more primary solid tubulars within the wellbore;  
fluidically coupling the primary solid tubulars with the casing;  
positioning one or more perforated tubulars within the wellbore, the perforated tubulars traversing the producing subterranean zone;  
fluidically coupling the perforated tubulars with the primary solid tubulars;  
fluidically isolating the producing subterranean zone from at least one other subterranean zone within the wellbore;  
fluidically coupling at least one of the perforated tubulars with the producing subterranean zone; and  
covering one or more of the perforations of one or more of the perforated tubular members using an elastic sealing member.

14. The method of claim 13, wherein the elastic sealing member comprises a swellable elastomeric sealing member that swells in the presence of fluidic materials.

15. The method of claim 13, further comprising:  
controllably fluidically decoupling at least one of the perforated tubulars from at least one other of the perforated tubulars.

25791.292

16. An apparatus, comprising:  
a subterranean formation including a wellbore;  
a zonal isolation assembly at least partially positioned within the wellbore comprising:  
one or more solid tubular members, each solid tubular member including one or more external seals; and  
one or more perforated tubular members coupled to the solid tubular members; and  
a shoe positioned within the wellbore coupled to the zonal isolation assembly;  
wherein at least one of the solid tubular members and the perforated tubular members are formed by a radial expansion process performed within the wellbore; and  
wherein one or more of the perforated tubular members include an elastic sealing member coupled to the perforated tubular member and covering one or more of the perforations of the perforated tubular member.
17. The apparatus of claim 16, wherein the elastic sealing member comprises a swellable elastomeric sealing member that swells in the presence of fluidic materials.
18. The apparatus of claim 16, wherein one or more of the external seals comprise a swellable elastomeric sealing member that swells in the presence of fluidic materials.
19. The apparatus of claim 16, wherein the zonal isolation assembly further comprises:  
one or more intermediate solid tubular members coupled to and interleaved among the perforated tubular members, each intermediate solid tubular member including one or more external seals;

25791.292

wherein at least one of the solid tubular members, the perforated tubular members, and the intermediate solid tubular members are formed by a radial expansion process performed within the wellbore.

20. The apparatus of claim 16, wherein the zonal isolation assembly further comprises one or more valve members for controlling the flow of fluids between the solid tubular members and the perforated tubular members.

21. The apparatus of claim 19, wherein one or more of the intermediate solid tubular members include one or more valve members for controlling the flow of fluids between the solid tubular members and the perforated tubular members.

22. An apparatus, comprising:

a subterranean formation including a wellbore;

a zonal isolation assembly positioned within the wellbore comprising:

one or more primary solid tubulars, each primary solid tubular including one or more external seals;

n perforated tubulars positioned coupled to the primary solid tubulars;

and

n-1 intermediate solid tubulars coupled to and interleaved among the perforated tubulars, each intermediate solid tubular including one or more external seals; and

a shoe coupled to the zonal isolation assembly;

wherein at least one of the primary solid tubulars, the perforated tubulars, and the intermediate solid tubulars are formed by a radial expansion process performed within the wellbore; and

wherein one or more of the perforated tubular members include an elastic sealing member coupled to the perforated tubular member and covering one or more of the perforations of the perforated tubular member.

23. The apparatus of claim 22, wherein the elastic sealing member comprises a swellable elastomeric sealing member that swells in the presence of fluidic materials.

25791.292

24. The apparatus of claim 22, wherein one or more of the external seals comprise a swellable elastomeric sealing member that swells in the presence of fluidic materials.

25. A method of isolating a first subterranean zone from a second subterranean zone in a wellbore, comprising:

positioning one or more primary solid tubulars within the wellbore, the primary solid tubulars traversing the first subterranean zone;  
positioning one or more perforated tubulars within the wellbore, the perforated tubulars traversing the second subterranean zone;  
radially expanding at least one of the primary solid tubulars and perforated tubulars within the wellbore;  
fluidicly coupling the perforated tubulars and the primary solid tubulars;  
preventing the passage of fluids from the first subterranean zone to the second subterranean zone within the wellbore external to the primary solid tubulars and perforated tubulars; and  
covering one or more of the perforations of one or more of the perforated tubular members using an elastic sealing member.

26. The method of claim 25, wherein the elastic sealing member comprises a swellable elastomeric sealing member that swells in the presence of fluidic materials.

27. A method of extracting materials from a producing subterranean zone in a wellbore, at least a portion of the wellbore including a casing, comprising:

positioning one or more primary solid tubulars within the wellbore;  
positioning one or more perforated tubulars within the wellbore, the perforated tubulars traversing the producing subterranean zone;  
radially expanding at least one of the primary solid tubulars and the perforated tubulars within the wellbore;  
fluidicly coupling the primary solid tubulars with the casing;  
fluidicly coupling the perforated tubulars with the primary solid tubulars;

25791.292

fluidically isolating the producing subterranean zone from at least one other subterranean zone within the wellbore;  
 fluidically coupling at least one of the perforated tubulars with the producing subterranean zone; and  
 covering one or more of the perforations of one or more of the perforated tubular members using an elastic sealing member.

28. The method of claim 27, wherein the elastic sealing member comprises a swellable elastomeric sealing member that swells in the presence of fluidic materials.

29. The method of claim 27, further comprising:  
 controllably fluidically decoupling at least one of the perforated tubulars from at least one other of the perforated tubulars.

30. An apparatus, comprising:  
 a subterranean formation including a wellbore;  
 a zonal isolation assembly positioned within the wellbore comprising:  
     n solid tubular members positioned within the wellbore, each solid tubular member including one or more external seals; and  
     n-1 perforated tubular members positioned within the wellbore coupled to and interleaved among the solid tubular members;  
 and  
 a shoe positioned within the wellbore coupled to the zonal isolation assembly;  
 wherein one or more of the perforated tubular members include a tubular elastic sealing member coupled to the perforated tubular member and covering one or more of the perforations of the perforated tubular member.

31. The apparatus of claim 30, wherein the elastic sealing member comprises a swellable elastomeric sealing member that swells in the presence of fluidic materials.

25791.292

32. The apparatus of claim 30, wherein one or more of the external seals comprise a swellable elastomeric sealing member that swells in the presence of fluidic materials.

33. The apparatus of claim 30, wherein the zonal isolation assembly further comprises one or more valve members for controlling the flow of fluids between the solid tubular members and the perforated tubular members.

34. The apparatus of claim 30, wherein one or more of the solid tubular members include one or more valve members for controlling the flow of fluids between the solid tubular members and the perforated tubular members.

35. A system for isolating a first subterranean zone from a second subterranean zone in a wellbore, comprising:

means for positioning one or more primary solid tubulars within the wellbore,  
the primary solid tubulars traversing the first subterranean zone;

means for positioning one or more perforated tubulars within the wellbore,  
the perforated tubulars traversing the second subterranean zone;

means for fluidicly coupling the perforated tubulars and the primary solid tubulars;

means for preventing the passage of fluids from the first subterranean zone to the second subterranean zone within the wellbore external to the primary solid tubulars and the perforated tubulars; and

means for sealing one or more of the perforations of one or more of the perforated tubular members.

36. A system for extracting materials from a producing subterranean zone in a wellbore, at least a portion of the wellbore including a casing, comprising;

means for positioning one or more primary solid tubulars within the wellbore;

means for fluidicly coupling the primary solid tubulars with the casing;

means for positioning one or more perforated tubulars within the wellbore,  
the perforated tubulars traversing the producing subterranean zone;

means for fluidicly coupling the perforated tubulars with the primary solid tubulars;

25791.292

means for fluidically isolating the producing subterranean zone from at least one other subterranean zone within the wellbore;

means for fluidically coupling at least one of the perforated tubulars with the producing subterranean zone; and

means for sealing one or more of the perforations of one or more of the perforated tubular members using an elastic sealing member.

37. The system of claim 36, further comprising:

means for controllably fluidically decoupling at least one of the perforated tubulars from at least one other of the perforated tubulars.

38. A system for isolating a first subterranean zone from a second subterranean zone in a wellbore, comprising:

means for positioning one or more primary solid tubulars within the wellbore, the primary solid tubulars traversing the first subterranean zone;

means for positioning one or more perforated tubulars within the wellbore, the perforated tubulars traversing the second subterranean zone;

means for radially expanding at least one of the primary solid tubulars and perforated tubulars within the wellbore;

means for fluidically coupling the perforated tubulars and the primary solid tubulars;

means for preventing the passage of fluids from the first subterranean zone to the second subterranean zone within the wellbore external to the primary solid tubulars and perforated tubulars; and

means for sealing one or more of the perforations of one or more of the perforated tubular members using an elastic sealing member.

39. A system for extracting materials from a producing subterranean zone in a wellbore, at least a portion of the wellbore including a casing, comprising:

means for positioning one or more primary solid tubulars within the wellbore;

means for positioning one or more perforated tubulars within the wellbore, the perforated tubulars traversing the producing subterranean zone;

means for radially expanding at least one of the primary solid tubulars and the perforated tubulars within the wellbore;

25791.292

means for fluidicly coupling the primary solid tubulars with the casing;  
 means for fluidicly coupling the perforated tubulars with the solid tubulars;  
 means for fluidicly isolating the producing subterranean zone from at least one other subterranean zone within the wellbore;  
 means for fluidicly coupling at least one of the perforated tubulars with the producing subterranean zone; and  
 means for sealing one or more of the perforations of one or more of the perforated tubular members using an elastic sealing member.

40. The system of claim 39, further comprising:  
 means for controllably fluidicly decoupling at least one of the perforated tubulars from at least one other of the perforated tubulars.
41. A system for isolating subterranean zones traversed by a wellbore, comprising:  
 a tubular support member defining a first passage;  
 a tubular expansion cone defining a second passage fluidicly coupled to the first passage coupled to an end of the tubular support member and comprising a tapered end;  
 a tubular liner coupled to and supported by the tapered end of the tubular expansion cone; and  
 a shoe defining a valveable passage coupled to an end of the tubular liner;  
 wherein the tubular liner comprises:  
 one or more expandable tubular members that each comprise:  
 a tubular body comprising an intermediate portion and first and second expanded end portions coupled to opposing ends of the intermediate portion; and  
 a sealing member coupled to the exterior surface of the intermediate portion; and  
 one or more perforated tubular members coupled to the expandable tubular members;  
 wherein the inside diameters of the perforated tubular members are greater than or equal to the outside diameter of the tubular expansion cone.

25791.292

42. The system of claim 41, wherein the wall thicknesses of the first and second expanded end portions are greater than the wall thickness of the intermediate portion.

43. The system of claim 41, wherein each expandable tubular member further comprises:

a first tubular transitional member coupled between the first expanded end portion and the intermediate portion; and

a second tubular transitional member coupled between the second expanded end portion and the intermediate portion;

wherein the angles of inclination of the first and second tubular transitional members relative to the intermediate portion ranges from about 0 to 30 degrees.

44. The system of claim 41, wherein the outside diameter of the intermediate portion ranges from about 75 percent to about 98 percent of the outside diameters of the first and second expanded end portions.

45. The system of claim 41, wherein the burst strength of the first and second expanded end portions is substantially equal to the burst strength of the intermediate tubular section.

46. The system of claim 41, wherein the ratio of the inside diameters of the first and second expanded end portions to the interior diameter of the intermediate portion ranges from about 100 to 120 percent.

47. The system of claim 41, wherein the relationship between the wall thicknesses  $t_1$ ,  $t_2$ , and  $t_{INT}$  of the first expanded end portion, the second expanded end portion, and the intermediate portion, respectively, of the expandable tubular members, the inside diameters  $D_1$ ,  $D_2$  and  $D_{INT}$  of the first expanded end portion, the second expanded end portion, and the intermediate portion, respectively, of the expandable tubular members, and the inside diameter  $D_{wellbore}$  of the wellbore casing that the expandable tubular member will be inserted into, and the outside diameter  $D_{cone}$  of the expansion cone that will be used to radially expand the

25791.292

expandable tubular member within the wellbore is given by the following expression:

$$D_{wellbore} - 2 * t_1 \geq D_1 \geq \frac{1}{t_1} [(t_1 - t_{INT}) * D_{cone} + t_{INT} * D_{INT}];$$

wherein  $t_1 = t_2$ ; and wherein  $D_1 = D_2$ .

48. The system of claim 41, wherein the tapered end of the tubular expansion cone comprises:

a plurality of adjacent discrete tapered sections.

49. The system of claim 48, wherein the angle of attack of the adjacent discrete tapered sections increases in a continuous manner from one end of the tubular expansion cone to the opposite end of the tubular expansion cone.

50. The system of claim 41, wherein the tapered end of the tubular expansion cone comprises:

an paraboloid body.

51. The system of claim 50, wherein the angle of attack of the outer surface of the paraboloid body increases in a continuous manner from one end of the paraboloid body to the opposite end of the paraboloid body.

52. The system of claim 41, wherein the tubular liner comprises a plurality of expandable tubular members; and wherein the other tubular members are interleaved among the expandable tubular members.

53. The system of claim 41, wherein one or more of the perforated tubular members include an elastic sealing member coupled to an exterior surface of the perforated tubular member and covering one or more of the perforations of the perforated tubular member.

25791.292

54. A method of isolating subterranean zones traversed by a wellbore, comprising:  
positioning a tubular liner within the wellbore; and  
radially expanding one or more discrete portions of the tubular liner into engagement with the wellbore;  
wherein the tubular liner comprises a plurality of tubular members; and  
wherein one or more of the tubular members are radially expanded into engagement with the wellbore and one or more of the tubular members are not radially expanded into engagement with the wellbore; and  
wherein the tubular liner comprises:  
one or more expandable tubular members that each comprise:  
a tubular body comprising an intermediate portion and first and second expanded end portions coupled to opposing ends of the intermediate portion; and  
a sealing member coupled to the exterior surface of the intermediate portion; and  
one or more perforated tubular members coupled to the expandable tubular members;  
wherein the inside diameters of the perforated tubular members are greater than or equal to the maximum inside diameters of the expandable tubular members.
55. The method of claim 54, wherein the tubular liner comprises a plurality of expandable tubular members; and wherein the perforated tubular members are interleaved among the expandable tubular members.
56. The method of claim 54, wherein one or more of the perforated tubular members include an elastic sealing member coupled to an exterior surface of the perforated tubular member and covering one or more of the perforations of the perforated tubular member.
57. An apparatus for isolating subterranean zones, comprising:  
a subterranean formation defining a borehole; and

25791.292

a tubular liner positioned in and coupled to the borehole at one or more discrete locations;

wherein the tubular liner comprises a plurality of tubular members; and wherein one or more of the tubular members are radially expanded into engagement with the borehole and one or more of the tubular members are not radially expanded into engagement with the borehole; and

wherein the tubular liner is coupled to the borehole by a process that comprises:

positioning the tubular liner within the borehole; and

radially expanding one or more discrete portions of the tubular liner into engagement with the borehole.

58. The system of claim 57, wherein prior to the radial expansion the tubular liner comprises:

one or more expandable tubular members that each comprise:

a tubular body comprising an intermediate portion and first and second expanded end portions coupled to opposing ends of the intermediate portion; and

a sealing member coupled to the exterior surface of the intermediate portion; and

one or more perforated tubular members coupled to the expandable tubular members;

wherein the inside diameters of the perforated tubular members are greater than or equal to the maximum inside diameters of the expandable tubular members.

59. The system of claim 58, wherein the tubular liner comprises a plurality of expandable tubular members; and wherein the perforated tubular members are interleaved among the expandable tubular members.

60. The apparatus of claim 57, wherein one or more of the perforated tubular members include a tubular elastic sealing member coupled to an exterior surface of

25791.292

the perforated tubular member and covering one or more of the perforations of the perforated tubular member.

61. A method of sealing an annulus between a wellbore and a tubular member positioned within the wellbore, comprising:

coupling a swellable elastomeric material to the exterior of the tubular member that swells in the presence of fluidic materials to sealingly engage the wellbore.

62. The method of claim 61, further comprising:

radially expanding and plastically deforming the tubular member within the wellbore.

63. The method of claim 61, wherein the tubular member defines one or more radial passages.

64. The method of claim 63, wherein the swellable elastomeric materials covers and seals one or more of the radial passages of the tubular member.

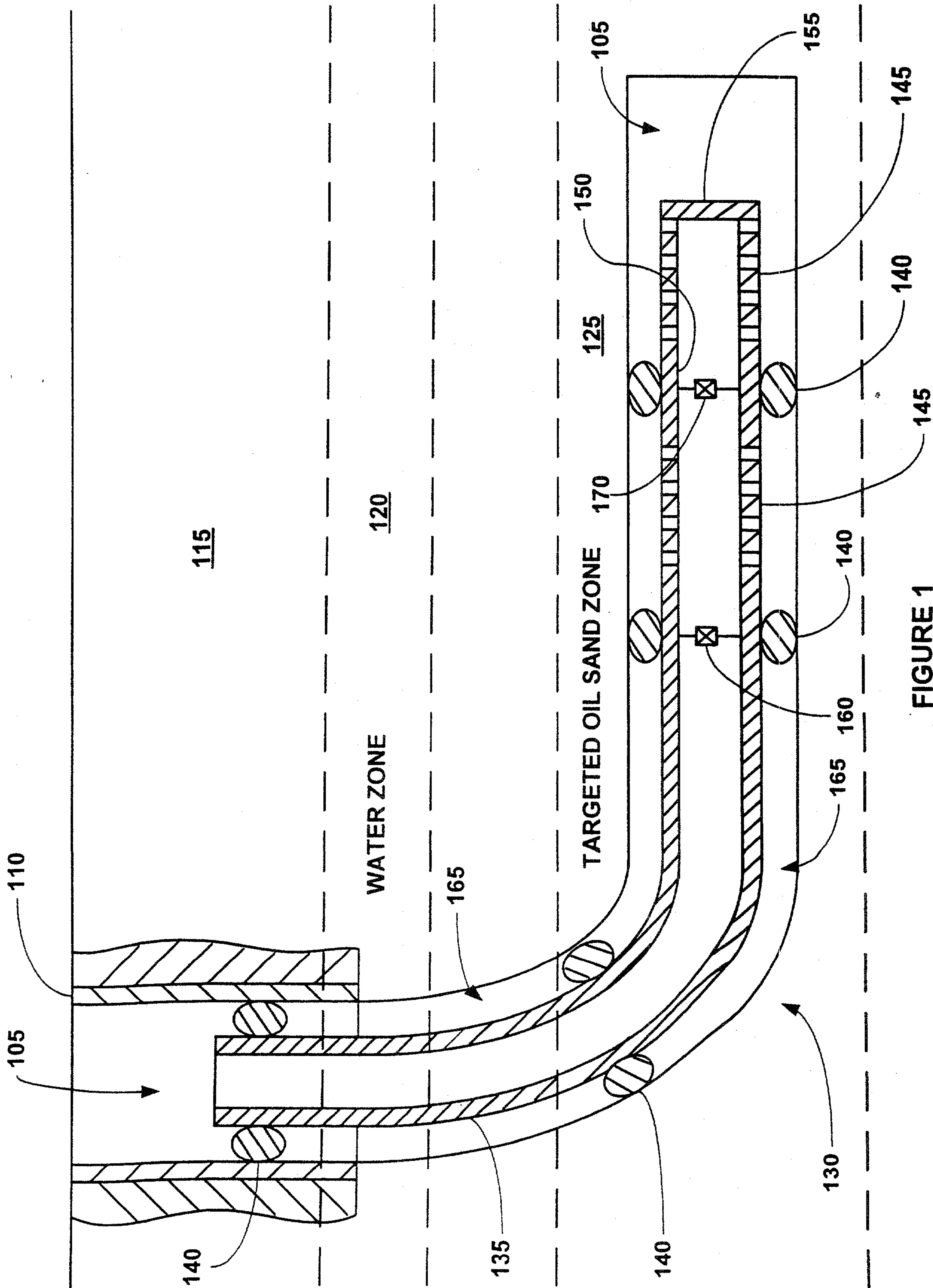

FIGURE 1

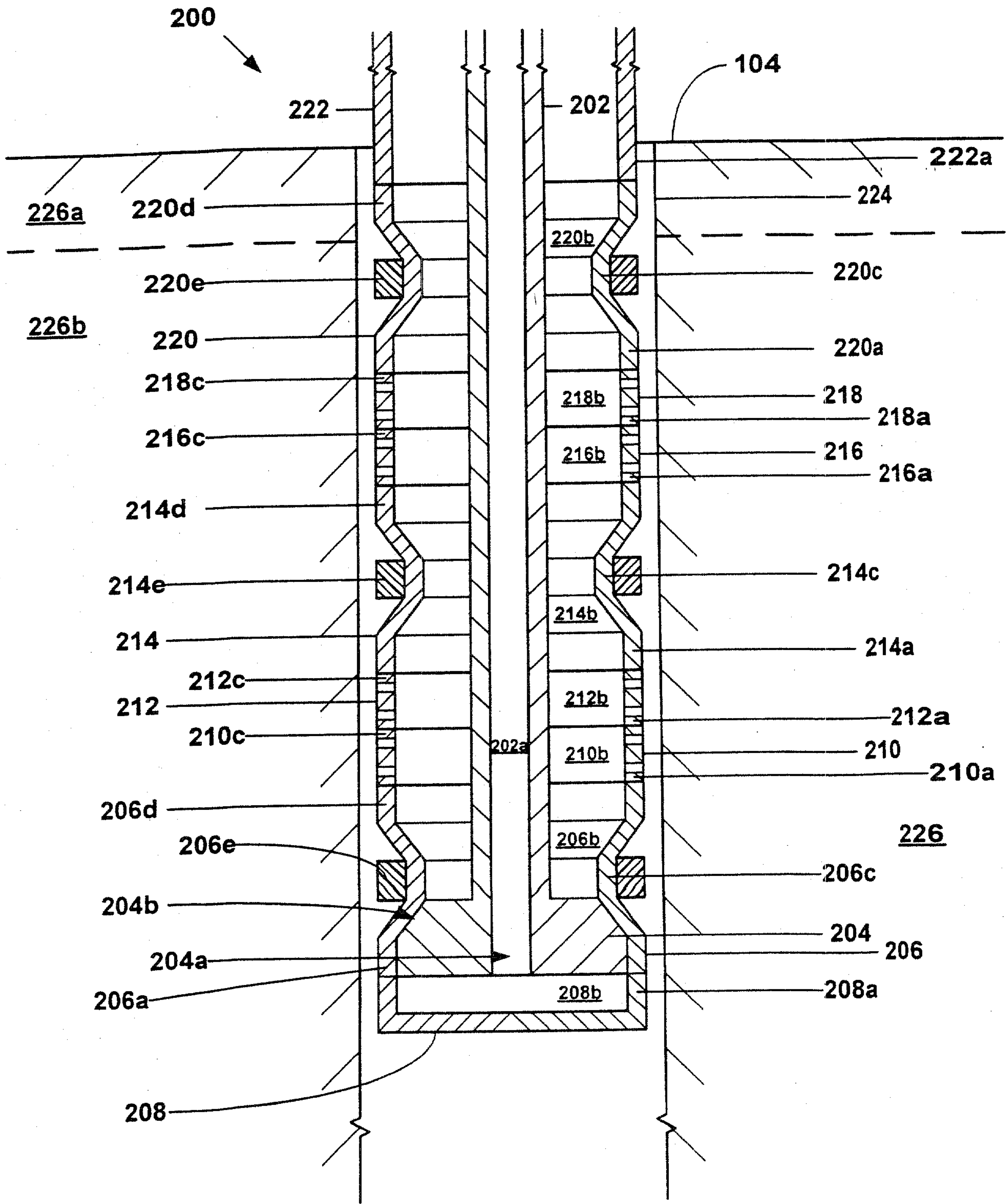

Fig. 2a

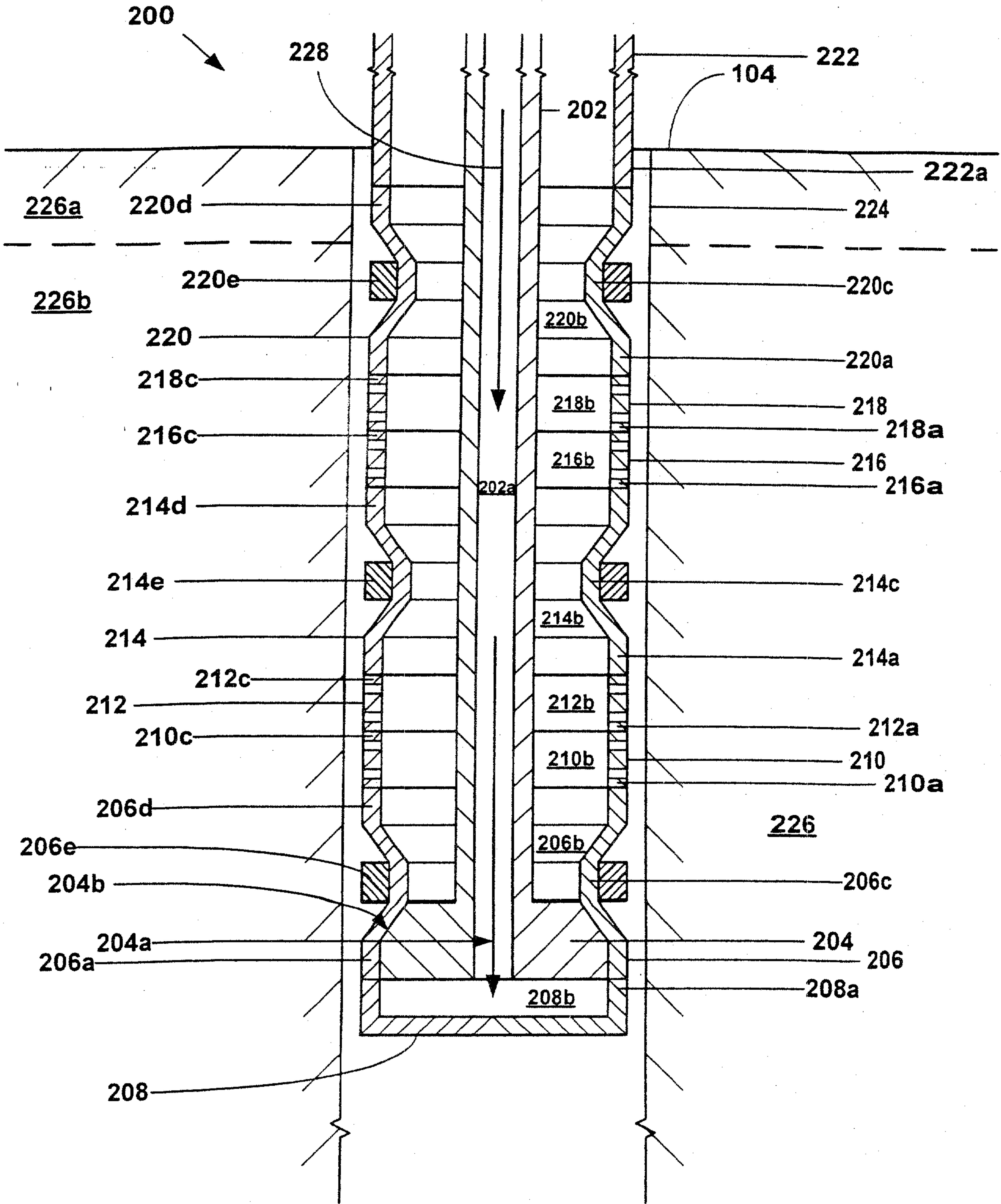

Fig. 2b



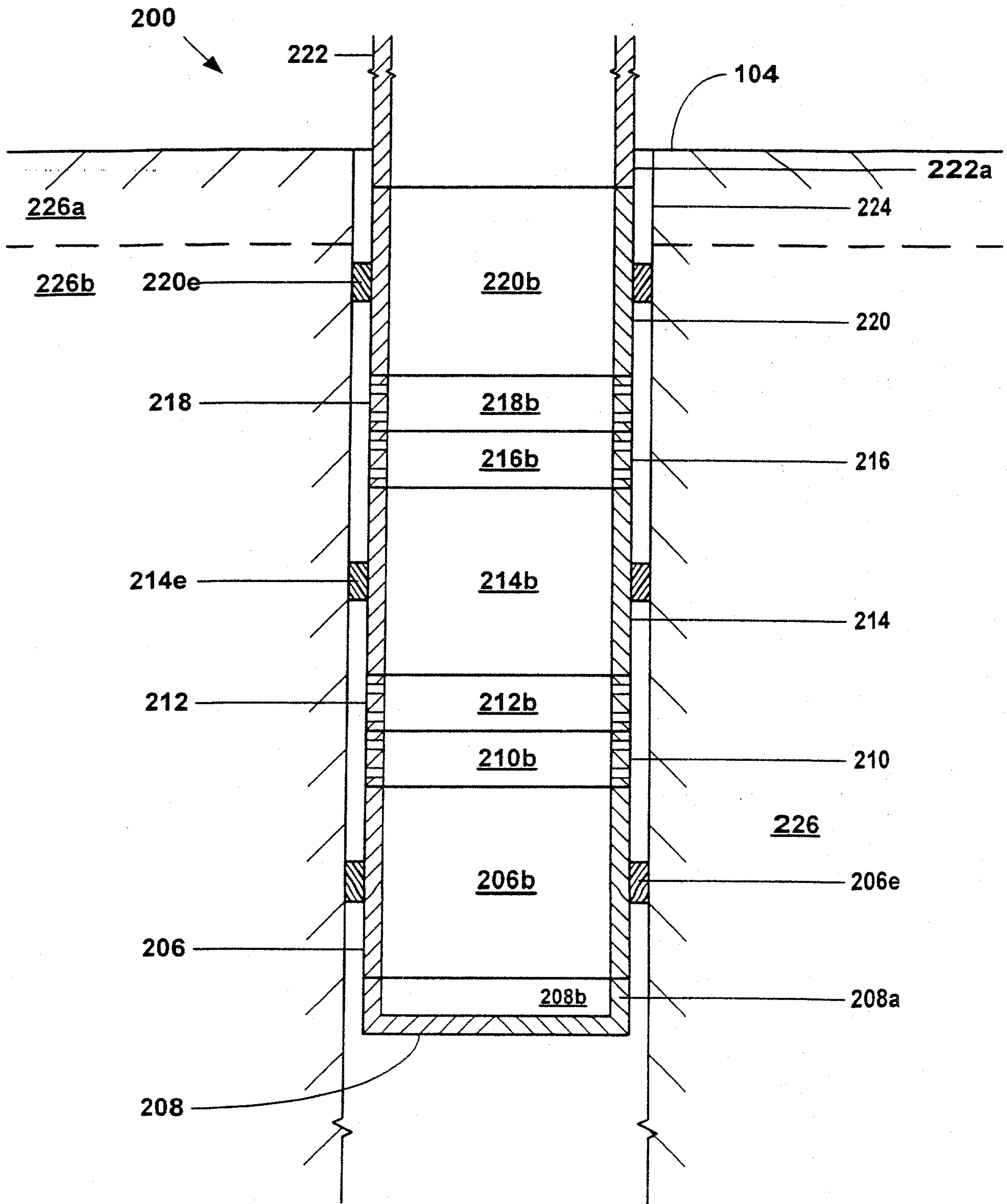

Fig. 2d

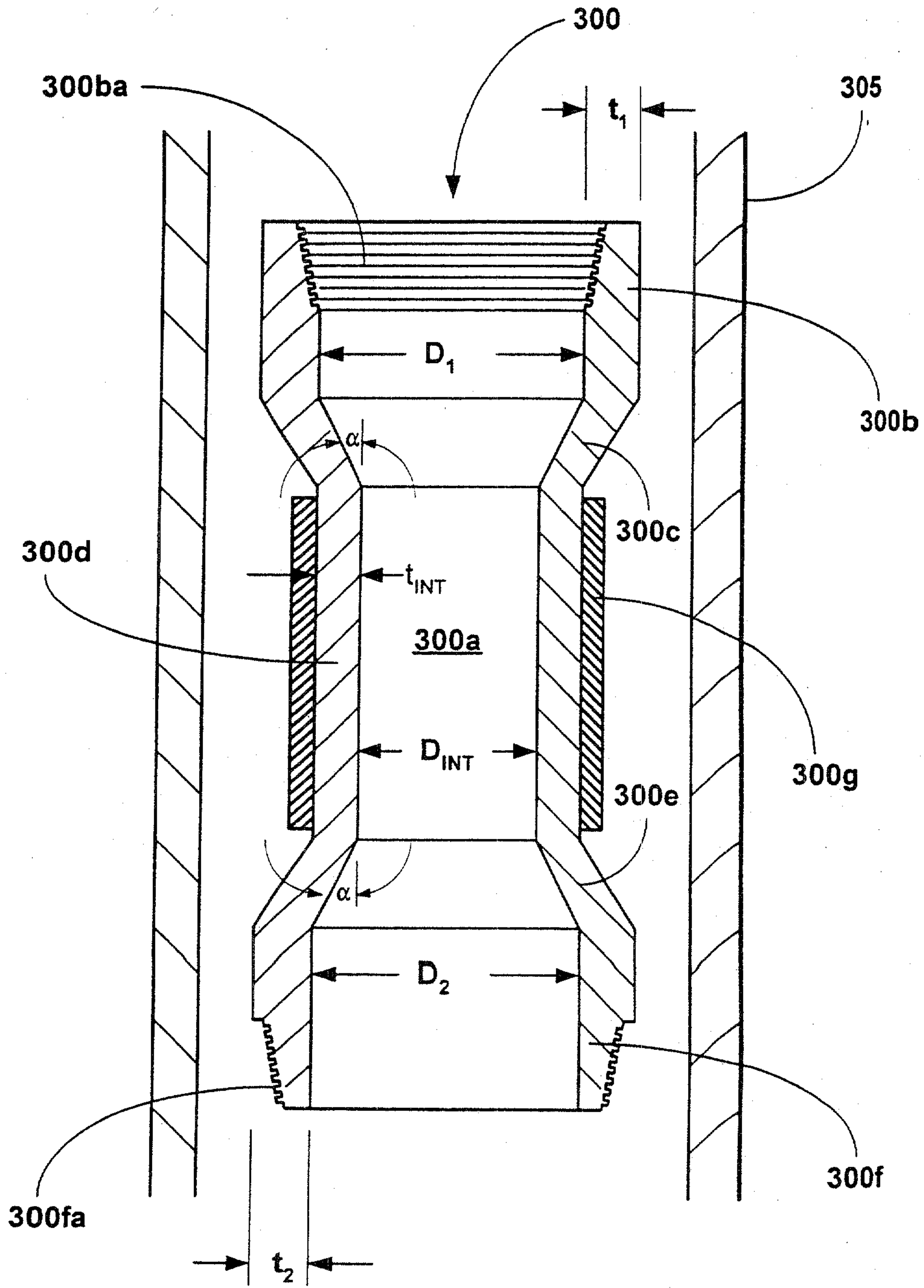

Fig. 3

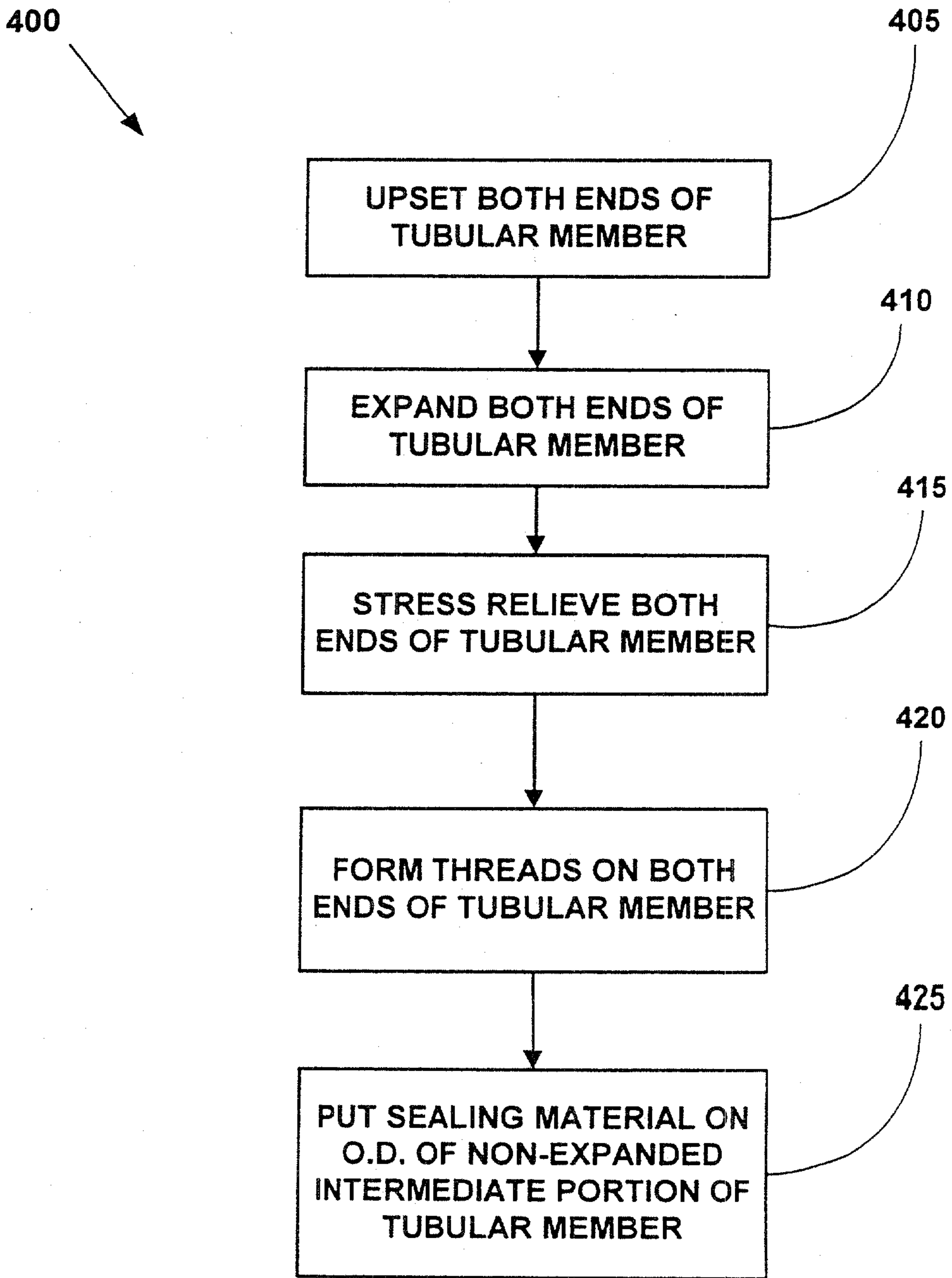
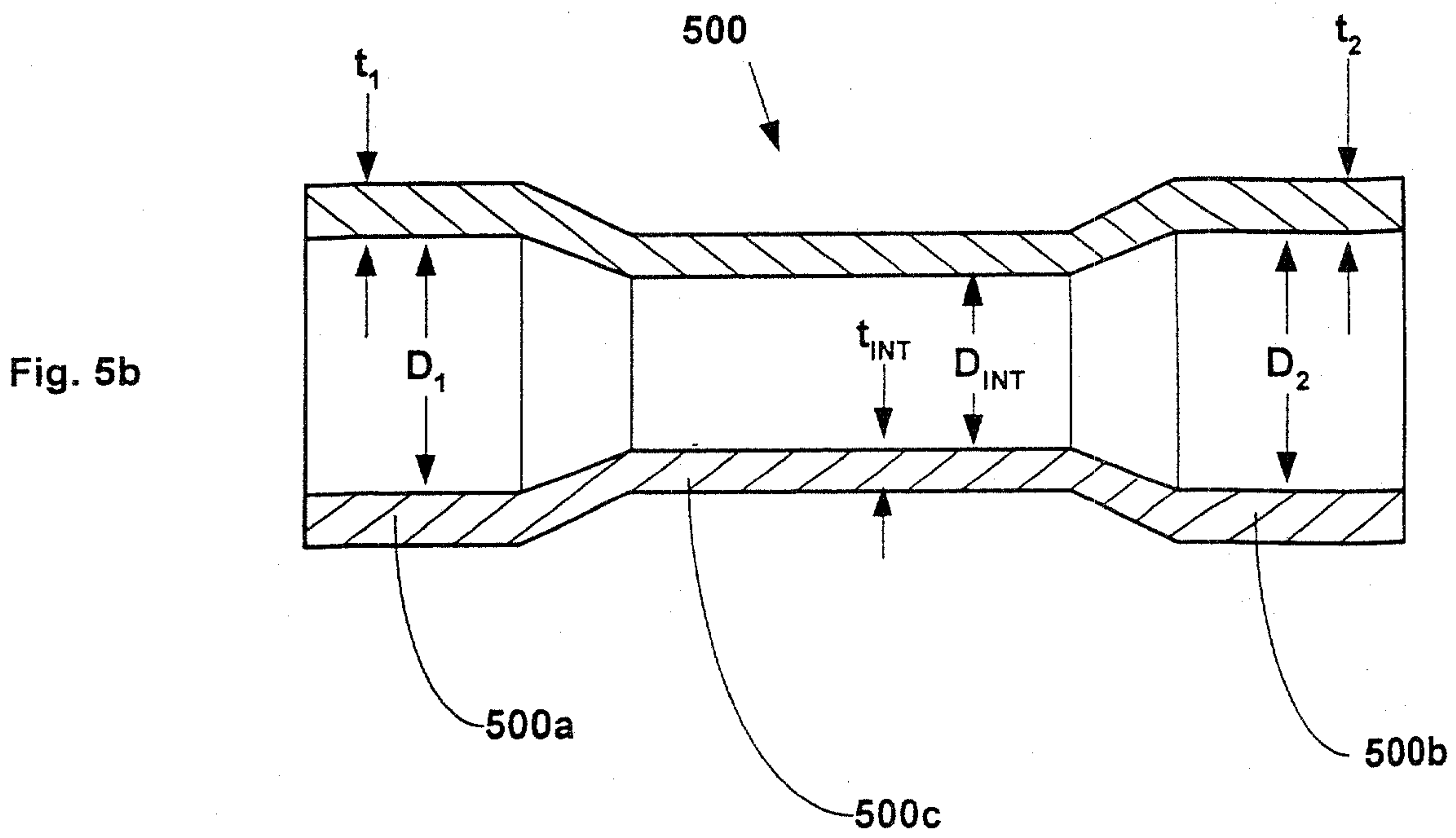
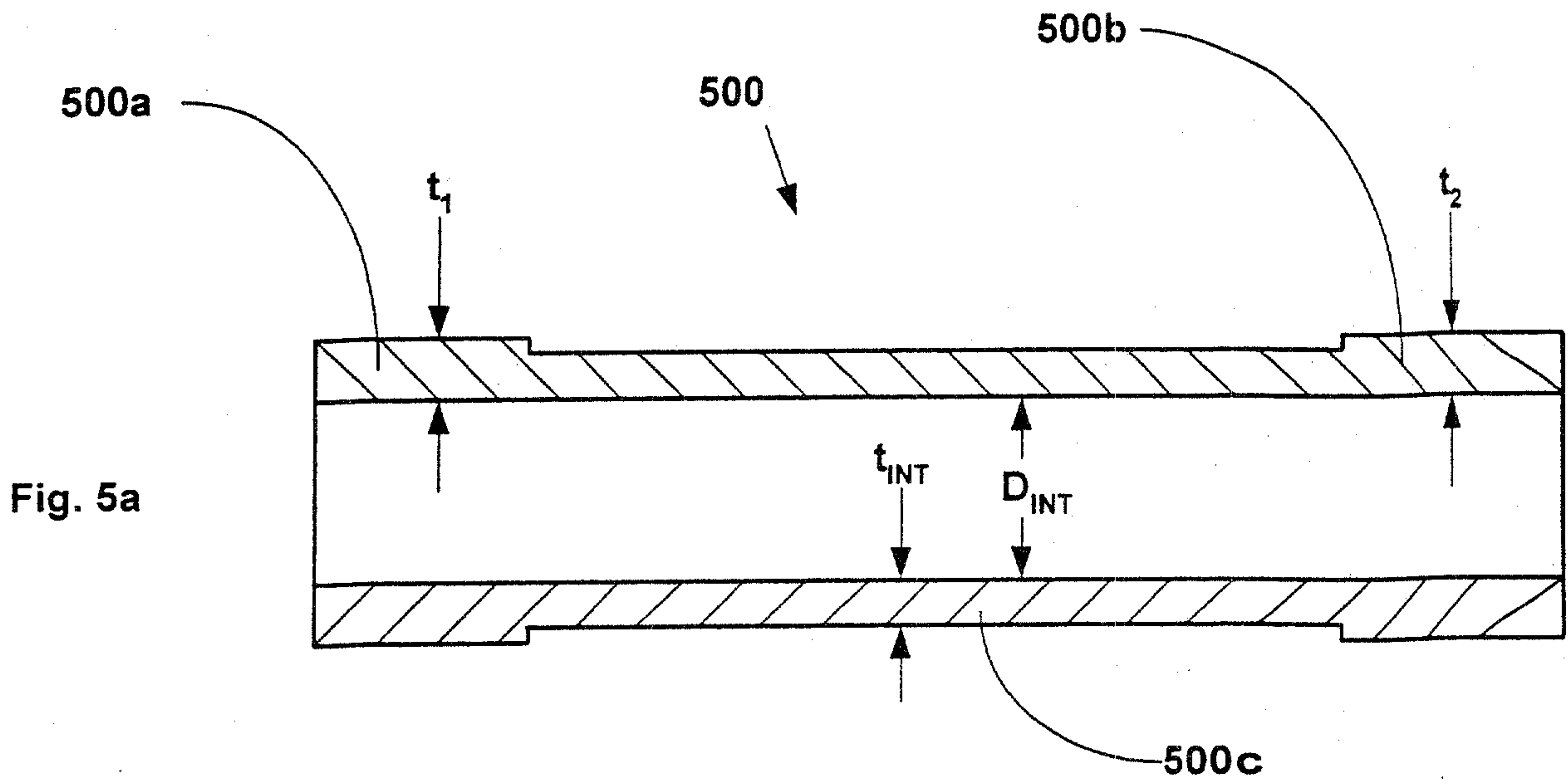

Fig. 4



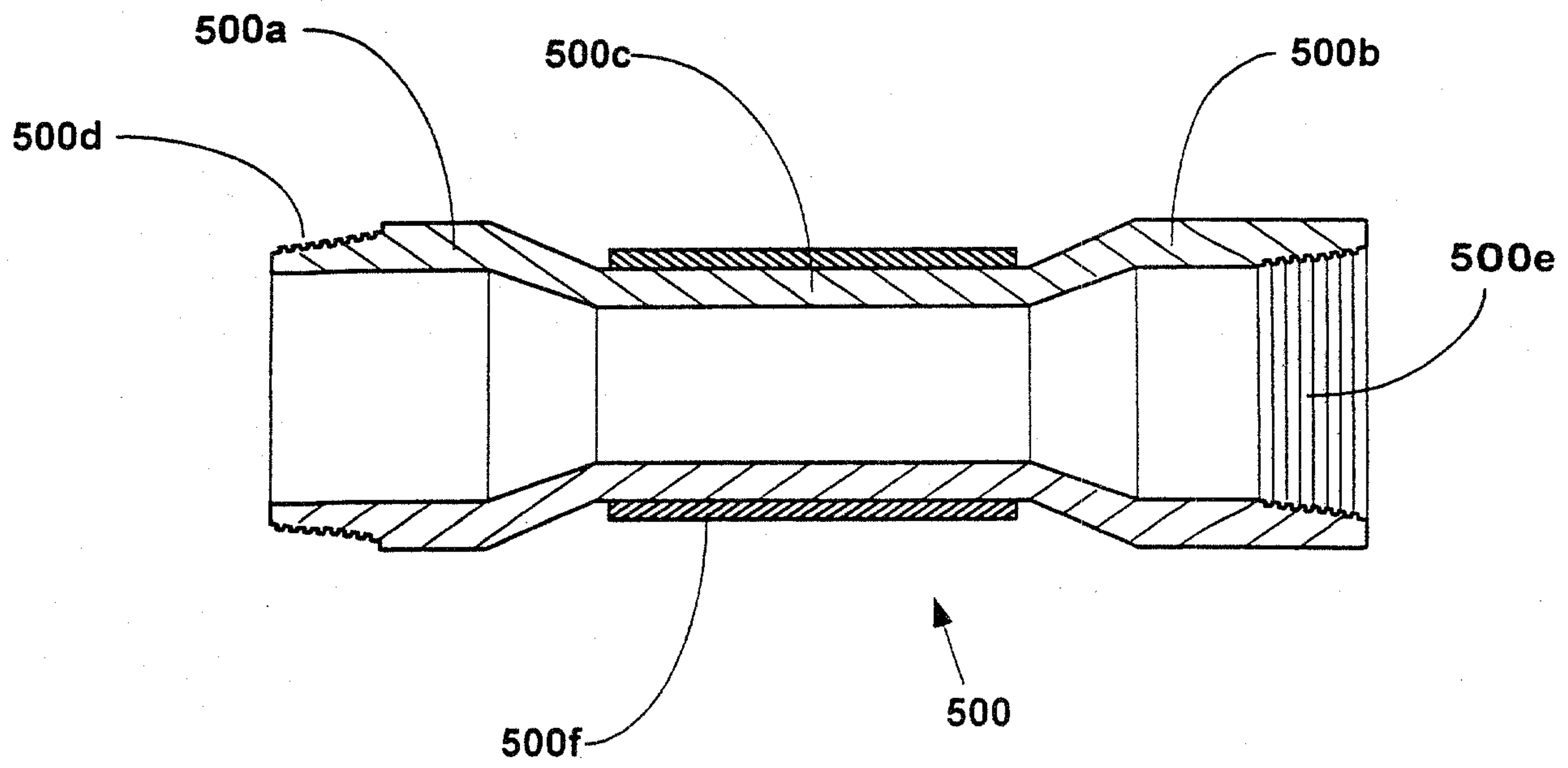
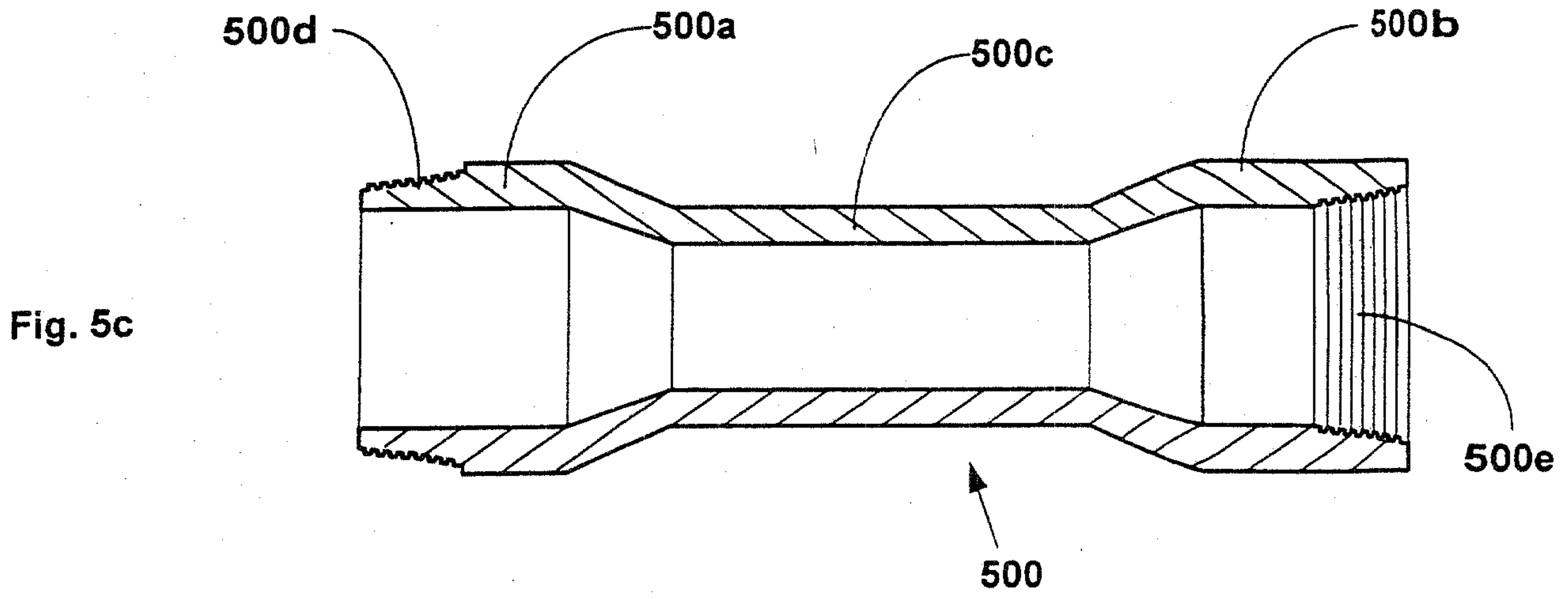

Fig. 5d

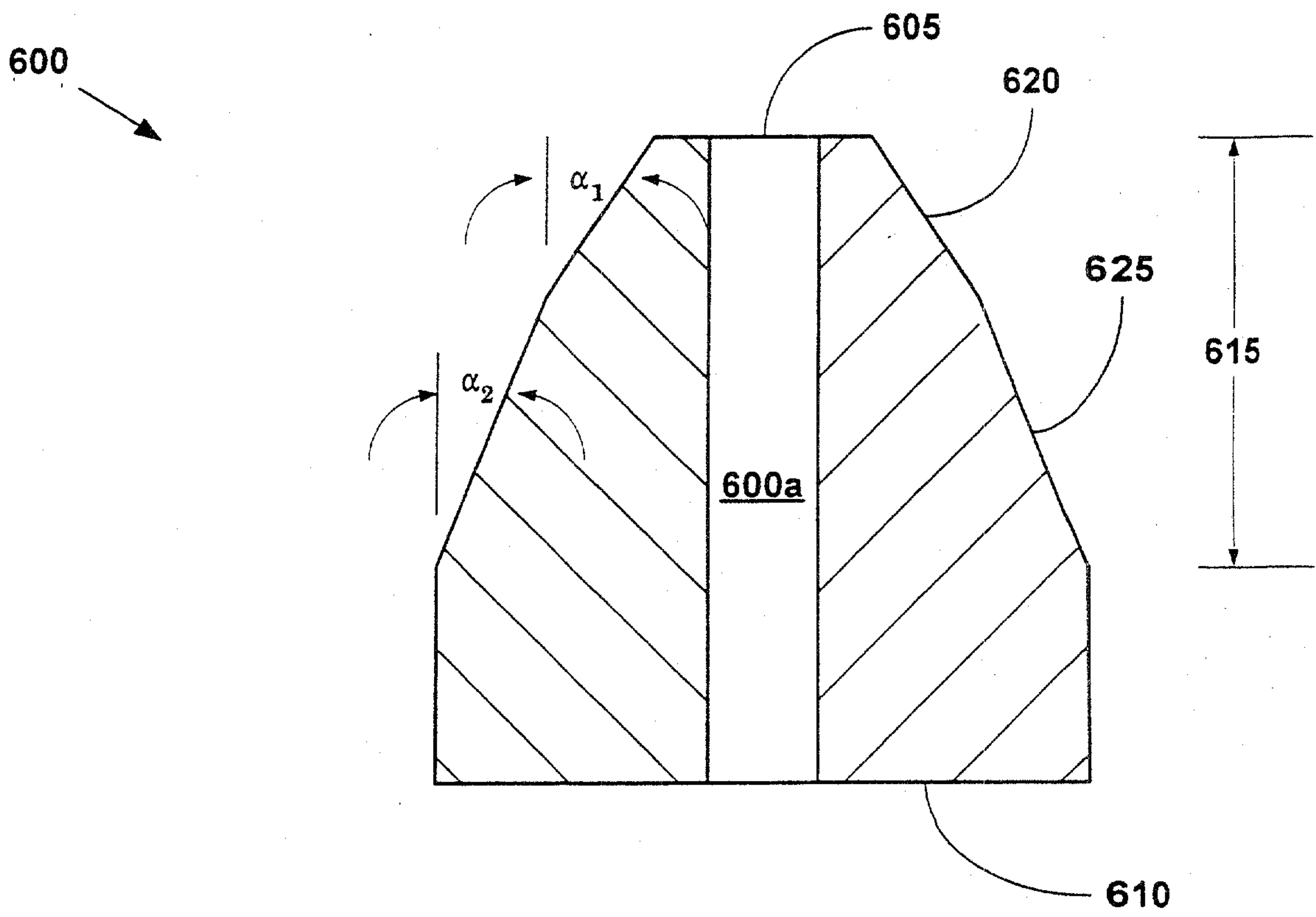

Fig. 6

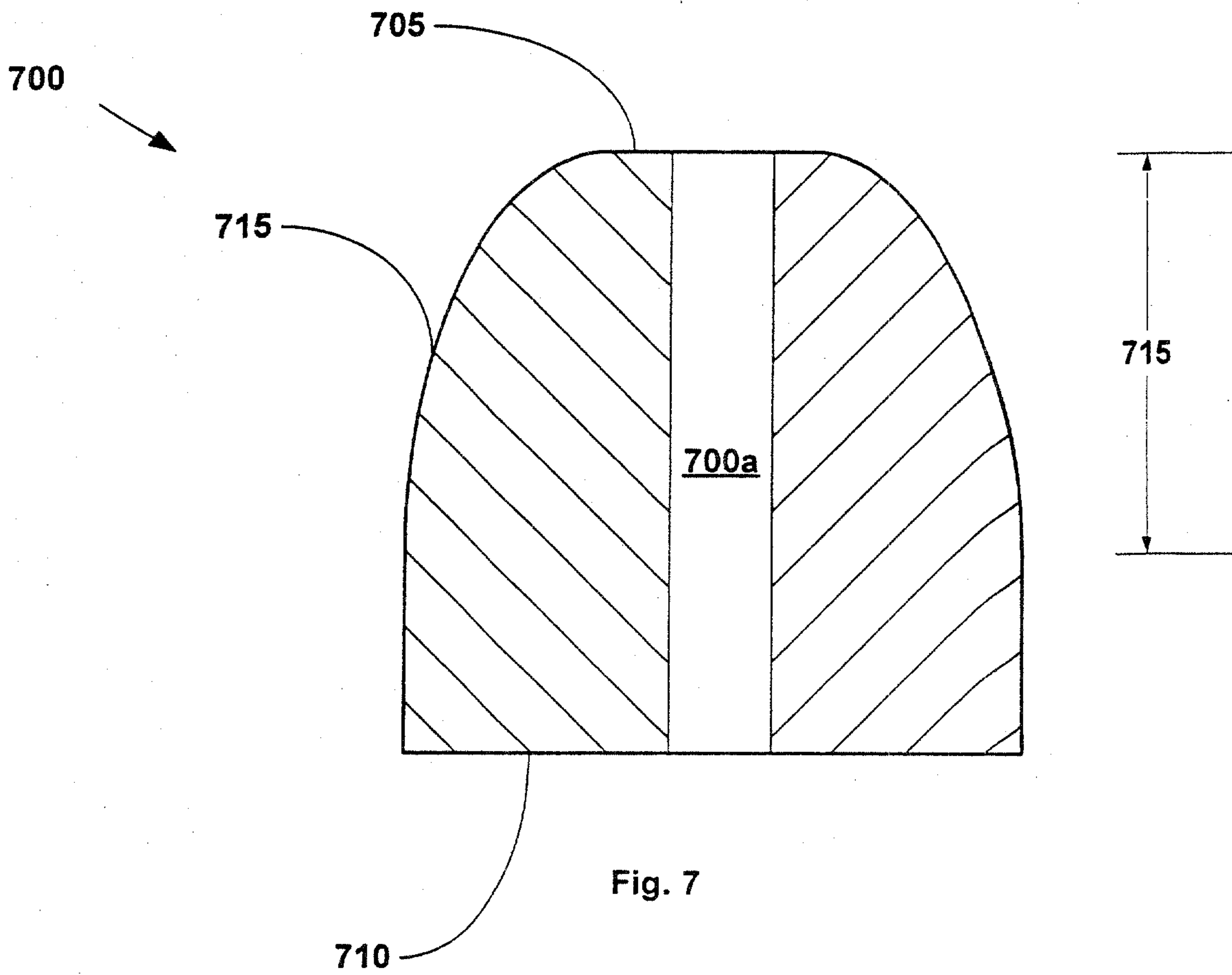

Fig. 7

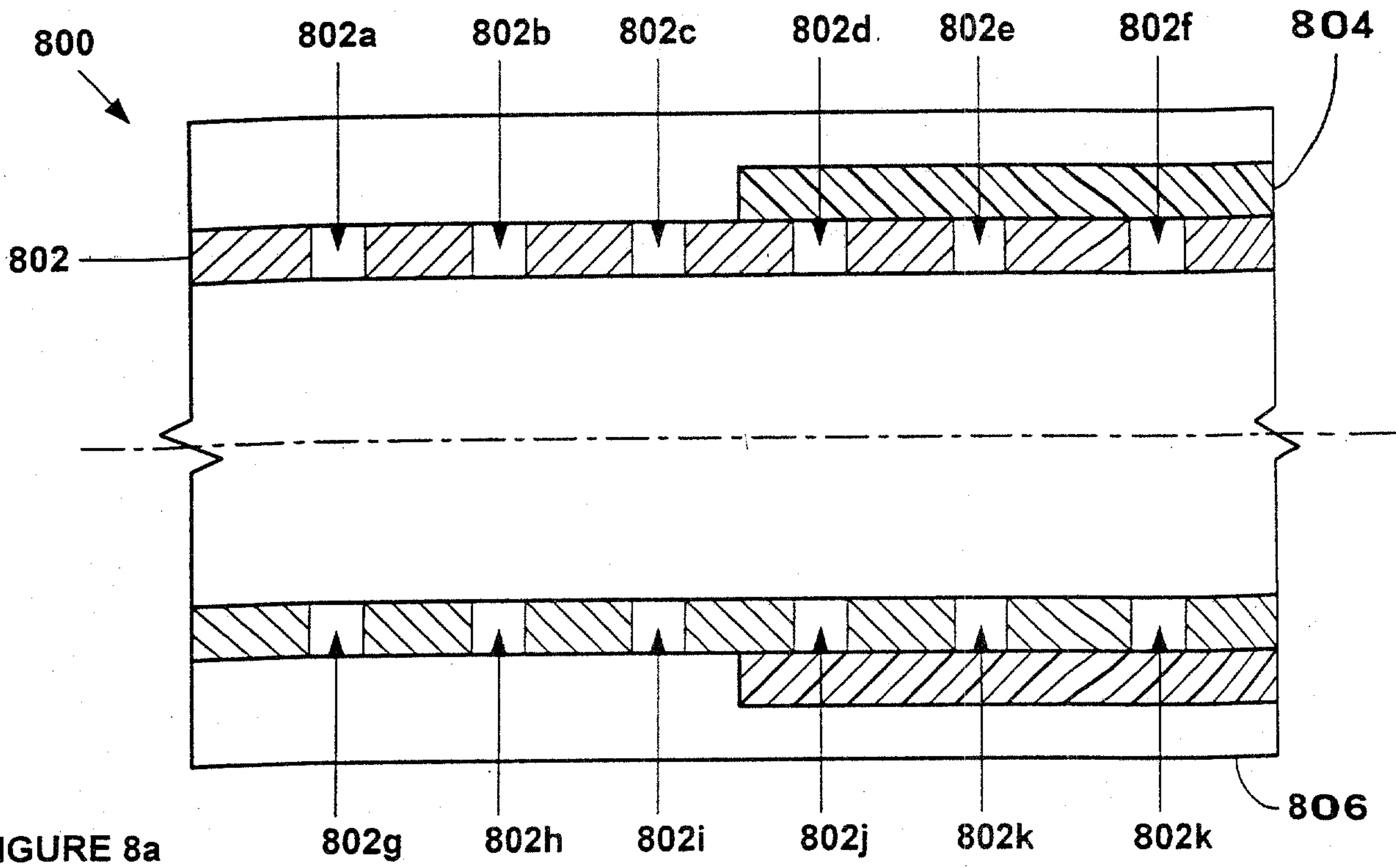

FIGURE 8a

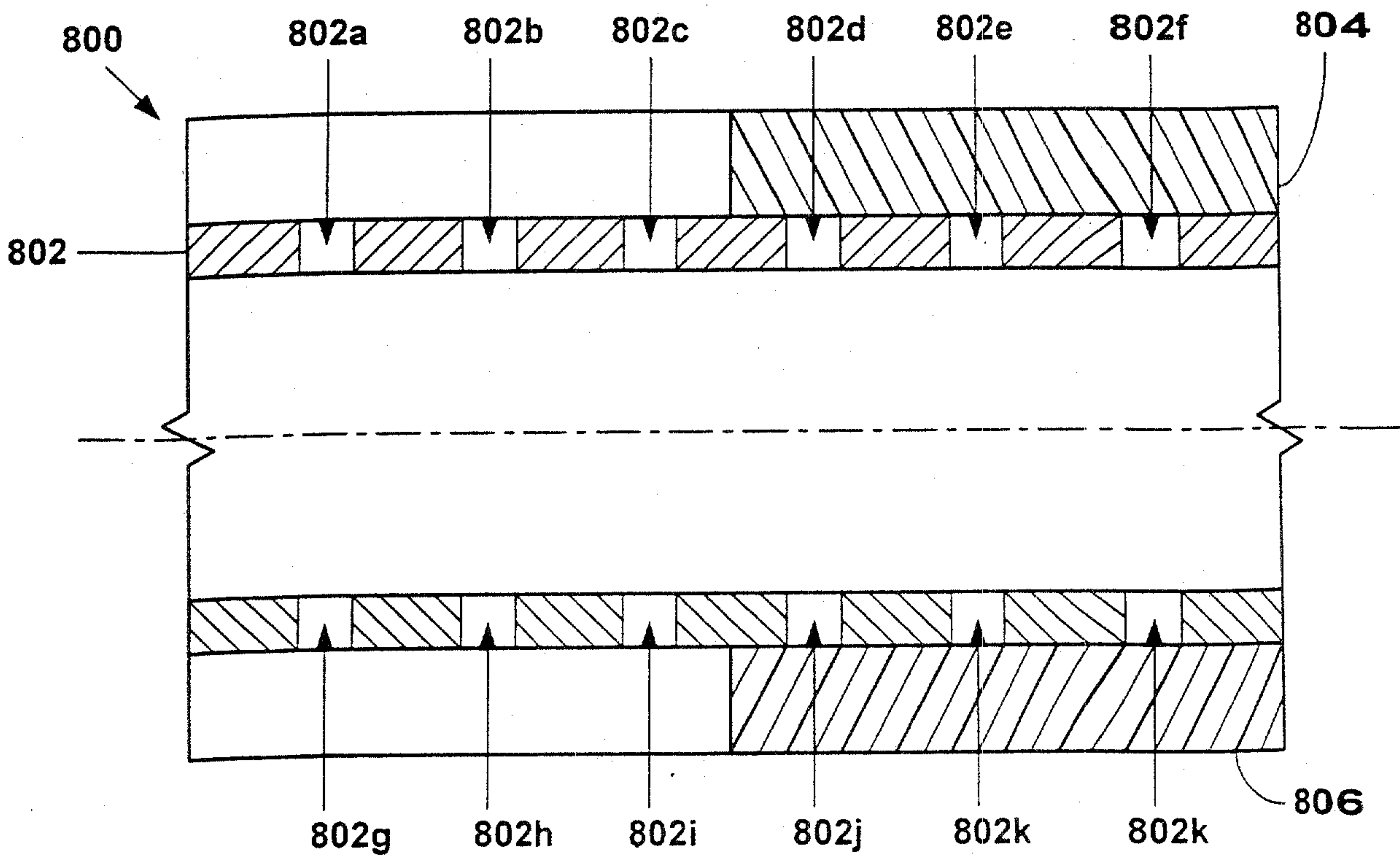

FIGURE 8b

