

(19) World Intellectual Property Organization
International Bureau



(43) International Publication Date
5 August 2010 (05.08.2010)

(10) International Publication Number
WO 2010/088554 A2

(51) International Patent Classification:
E03D 13/00 (2006.01) *A61L 2/26* (2006.01)
A61L 2/16 (2006.01)

Christian [US/US]; 299 South Millpond Drive, Lehi, UT 84043 (US).

(21) International Application Number:
PCT/US2010/022646

(74) Agent: **HOWARTH, Alan, J.**; Clayton, Howarth & Cannon, P.C., P.O. Box 1909, Sandy, UT 84091 (US).

(22) International Filing Date:
29 January 2010 (29.01.2010)

(81) Designated States (unless otherwise indicated, for every kind of national protection available): AE, AG, AL, AM, AO, AT, AU, AZ, BA, BB, BG, BH, BR, BW, BY, BZ, CA, CH, CL, CN, CO, CR, CU, CZ, DE, DK, DM, DO, DZ, EC, EE, EG, ES, FI, GB, GD, GE, GH, GM, GT, HN, HR, HU, ID, IL, IN, IS, JP, KE, KG, KM, KN, KP, KR, KZ, LA, LC, LK, LR, LS, LT, LU, LY, MA, MD, ME, MG, MK, MN, MW, MX, MY, MZ, NA, NG, NI, NO, NZ, OM, PE, PG, PH, PL, PT, RO, RS, RU, SC, SD, SE, SG, SK, SL, SM, ST, SV, SY, TH, TJ, TM, TN, TR, TT, TZ, UA, UG, US, UZ, VC, VN, ZA, ZM, ZW.

(25) Filing Language: English

(26) Publication Language: English

(30) Priority Data:
61/148,812 30 January 2009 (30.01.2009) US

(71) Applicant (for all designated States except US): **F-MAT-IC, INC.** [US/US]; 299 South Millpond Drive, Lehi, UT 84043 (US).

(72) Inventors; and

(75) Inventors/Applicants (for US only): **MIYAGI, Haruyoshi** [US/US]; 299 South Millpond Drive, Lehi, UT 84043 (US). **RODRIGUE, Daniel, J.** [US/US]; 299 South Millpond Drive, Lehi, UT 84043 (US). **WEAVER,**

(84) Designated States (unless otherwise indicated, for every kind of regional protection available): ARIPO (BW, GH, GM, KE, LS, MW, MZ, NA, SD, SL, SZ, TZ, UG, ZM, ZW), Eurasian (AM, AZ, BY, KG, KZ, MD, RU, TJ, TM), European (AT, BE, BG, CH, CY, CZ, DE, DK, EE, ES, FI, FR, GB, GR, HR, HU, IE, IS, IT, LT, LU, LV,

[Continued on next page]

(54) Title: URINAL CLEANING AND DEODORIZING APPARATUS AND METHOD

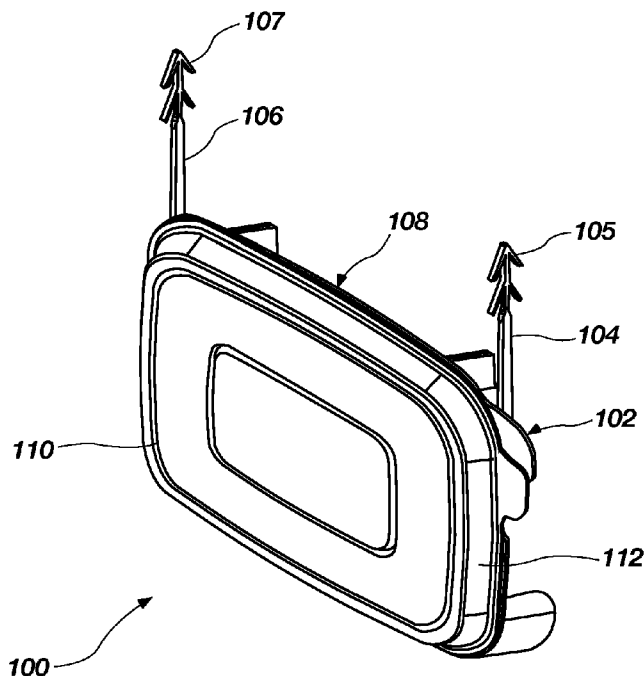

FIG. 1

(57) Abstract: A urinal cleaning unit for cleaning a urinal having periodic water flow therethrough comprises: (a) a mounting device for attaching the urinal clean unit to a urinal; (b) a disposable unit adapted for releasably attaching to the mounting device; and (c) a chamber in the disposable unit for containing a cleaning agent adapted to intercept a portion of the water flow. A method of cleaning a urinal having periodic water flow therethrough comprises: (a) mounting a disposable unit to a urinal; (b) enabling a portion of the water flow to flow through the disposable unit; and (c) mixing the portion of the water flow with a cleaning agent in the disposable unit to form a mixture of water and cleaning agent; and (d) releasing the mixture of water and cleaning agent to the urinal.



WO 2010/088554 A2

MC, MK, MT, NL, NO, PL, PT, RO, SE, SI, SK, SM, **Published:**
TR), OAPI (BF, BJ, CF, CG, CI, CM, GA, GN, GQ, GW, — *without international search report and to be republished*
ML, MR, NE, SN, TD, TG). *upon receipt of that report (Rule 48.2(g))*

URINAL CLEANING AND DEODORIZING APPARATUS AND METHOD**BACKGROUND OF THE INVENTION**

In public restrooms, such as in commercial buildings and restaurants, urinals are used constantly and require frequent cleaning and maintenance. Even with frequent
5 cleaning, unpleasant odors are frequently emitted from urinals. Thus, it is important to have a means to clean and deodorize urinals on a regular basis.

Current products on the market tend to have a number of problems. It is difficult to mount urinal cleaning units in some urinals. Some urinal cleaner-deodorizers are designed only to fit certain types of urinals and do not have universal usage. Others,
10 such as drip systems, are cumbersome to install and use.

Many urinal cleaners do not provide for disposable refills, and the entire unit must be discarded. Other urinal cleaner-deodorizers utilize refills but are awkward or difficult to replace. Moreover, some refill units are not structured to utilize the cleaning chemicals slowly and they are quickly used up so that they lose their effectiveness within
15 a few days.

Simple puck-type units, referred to as parablocks, are sometime used that are just placed in the bottom of the urinal. Typically these units do not clean the urinal walls, where odor can build up. Moreover, some parablock units are dangerous, in that the fumes and water from the same have been known to be associated with disease.
20

SUMMARY OF THE INVENTION

A urinal cleaning unit for cleaning a urinal having periodic water flow therethrough comprises: (a) a mounting device for attaching the urinal cleaning unit to a urinal; (b) a disposable unit adapted for releasably attaching to the mounting device; and (c) a chamber in the disposable unit for containing a cleaning agent adapted to intercept
25 a portion of the water flow.

A method of cleaning a urinal having periodic water flow therethrough comprises: (a) mounting a disposable unit to a urinal; (b) enabling a portion of the water flow to flow through the disposable unit; and (c) mixing the portion of the water flow with a cleaning agent in the disposable unit to form a mixture of water and cleaning
30 agent; and (d) releasing the mixture of water and cleaning agent to the urinal.

BRIEF DESCRIPTION OF DRAWINGS

In the detailed description that follows, reference will be made to the following Figures, in which:

5 Figure 1 is a perspective view of a urinal cleaner and deodorizer according to one embodiment of the present invention;

Figure 2 is an exploded perspective view of a urinal cleaner and deodorizer according the embodiment shown in Figure 1;

Figures 3 and 4 are side views of a urinal cleaner and deodorizer according to the embodiment shown in Figure 1;

10 Figure 4A is a bottom view of a urinal cleaner and deodorizer according to the embodiment shown in Figure 1;

Figures 5 and 6 are perspective and back views, respectively, of a urinal cleaner and deodorizer according to the embodiment shown in Figure 1;

15 Figure 6A is a bottom view of a refill cartridge according to the embodiment shown in Figure 1;

Figure 7 is an exploded perspective view of a refill cartridge for a urinal cleaner and deodorizer according the embodiment shown in Figure 1;

Figure 8 is a side view showing the assembly of a urinal cleaner and deodorizer according the embodiment shown in Figure 1;

20 Figure 9 is a top view of a urinal cleaner and deodorizer being installed into a urinal according the embodiment shown in Figure 1; and

Figure 10 is a front view of a urinal cleaner and deodorizer installed into a urinal according the embodiment shown in Figure 1.

DETAILED DESCRIPTION OF THE DISCLOSURE

25 The present invention, as described in the following illustrative embodiments, provides a number of advantages over the existing prior art. The cleaning and deodorizing unit disclosed herein is light and easy to manufacture and ship. Its structure makes it easy to install and remove from urinals. The refill cartridge disclosed herein is easy and simple to install and remove. The placement of the cleaning unit insures
30 comprehensive coverage and cleaning of a urinal unit. The structure of the refill housing enables slow and steady release of the chemicals therein so that the life of the refill is substantially extended. The cleaning chemicals are effective in removing calcium buildup in the urinal and the urinal drain pipes, thereby reducing unpleasant odors from the urinal and preventing clogged urinal drain pipes. The fragrance unit is also

structured for slow steady release over a long period of time. The simple structure of the cleaning and deodorizing unit make the system inexpensive and environmentally friendly.

Referring to Figure 1, an illustrative embodiment of the present invention is shown. A urinal cleaner 100 comprises a combination cleaner and deodorizer for urinals. In the present embodiment, the urinal cleaner 100 contains both a scented fragrance cap for deodorizing and a cleaning agent, such as sulfamic acid mix, for cleaning. The urinal cleaner 100 is designed to last between 30 and 60 days, depending on a variety of factors including, without limitation, the frequency of flush, duration of flush, water pressure, and the substrate used. It is partially replaceable, having a semi-permanent component that easily attaches to nearly all urinals and a temporary refill component that easily connects and disconnects from the semi-permanent component. The semi-permanent component can also be easily removed from a urinal and discarded or recycled.

Looking again at Figure 1, the urinal cleaner 100 is comprised of a mounting bracket or collar 102 (not clearly shown here) having attachment barbed arms 104 and 106 extending upward and having barbs 105 and 107 for connection to a urinal, discussed below. A refill cartridge 108 is attached to the mounting bracket 102 in a manner to be discussed later. A rectangular-shaped fragrance cap 110 is attached to the top of refill cartridge 108 as shown. The cap 110 may be designed primarily to overcome urinal odors. The fragrance cap 110 may be made from a plastic material and injected with high quality fragrance oils. The fragrance cap 110 may be designed to snap into a channel (not shown here) in a front housing 112 of refill cartridge 108.

Figure 2 shows the components of the urinal cleaner 100 in an exploded view. Mounting bracket 102 is comprised of a stationary rectangular-shaped piece 120 forming a rectangular opening 124 in which the refill cartridge 108 is connected. On both sides of piece 120 are formed swivel joints 122, 123 to which attachment arms 104 and 106 are connected. Four posts 126a, 126b, 126c and 126d are formed on the backside of the corners of rectangular-shaped piece 120. These posts provide a means to space the urinal cleaning unit 100 away from a urinal wall, facilitating easy change of refill units. Swivel joints 122, 123 enable the attachment arms 104 and 106 to be rotated about 60 degrees, to enable connection to a variety of urinal configurations.

In Figure 2 refill cartridge 108 is again shown. The rectangular shape of the refill cartridge 108 enables it to be easily snapped into the opening 124 formed by rectangular-

shaped piece 120. A tab 130 at a corner of refill cartridge 108 is disposed to be offset slightly from a similar tab 132 on the rectangular-shaped piece 120 of mounting bracket 102, to enable one to separate the refill cartridge 108 from the mounting bracket 102. A rectangular-shaped channel 136 is formed in the top of front housing 112 of refill
5 cartridge 108 to accommodate rectangular-shaped fragrance cap 110.

Figure 3 is a left side view showing the urinal cleaner 100 with arm 106 extended outward from mounting bracket 102. A lower lip 140 is formed along the bottom of mounting bracket 102. Lower lip 140, together with the support posts 126a, b, c and d (not shown here) provide a means to space the urinal cleaning unit 100 away from a
10 urinal wall, facilitating easy change of refill units. The lower lip 140 also acts to direct the water flow toward the urinal wall and away from a user. Refill cartridge 108 is shown connected to mounting bracket 102. The back housing 113 of the refill cartridge 108 comprises a chemical chamber 150, discussed in more detail below.

Figure 4 is a top side view of the urinal cleaner 100 in Figure 1 showing arms
15 104 and 106. Front housing 112 of refill cartridge 108 is positioned below rectangular-shaped piece 120 that forms mounting bracket 102. Chamber 150 is disposed above piece 120 in opening 124 (shown in Figure 2) that is formed by piece 120. Ridges 155 (not shown) and 156 are disposed at the top and base of chamber 150 to enable the refill cartridge 108 to snap into place in opening 124 of mounting bracket 102.

Figure 4A is a bottom view of the urinal cleaner 100 of Figure 1, showing the
20 lower lip 140 formed along the bottom of the mounting bracket 102.

Figures 5 and 6 show the back housing 113 of refill cartridge 108. A chemical chamber 150 is formed in back housing 113 and sealed to front housing 112, providing a pocket to contain a cleaning agent, used to clean a urinal and urinal pipes. Holes 152
25 and 153 are formed in a portion of back housing 113 facing in the same direction as barbed arms 104 and 106 for allowing urinal water into chemical chamber 150, as discussed below. A larger hole 154 (shown in Figure 6) is formed near the bottom of back housing 113 to allow water containing the cleaning agent to leave chamber 150. Ridge 155 is shown at the top of chamber 150 that functions with ridge 156 (shown in
30 Figure 4) to hold the refill cartridge 108 connected to mounting bracket 102.

Figure 6A shows the bottom of the refill cartridge 108. Ridge 155 is shown, which functions in snapping the refill cartridge 108 into place in opening 124 of the mounting bracket 102. Hole 124 in chemical chamber 150 is also shown.

Figure 7 shows the refill cartridge 108 in an exploded view. As shown in Figure 2, the fragrance cap 110 is shown separated from rectangular channel 124 in front housing 112. Rear housing 113 is shown, comprising chemical chamber 150. A timed release pouch 160 is shown that is normally enclosed chemical chamber 150. Timed release pouch 160 contains the cleaning agent, which in the present embodiment may be a sulfamic acid mixture for cleaning a urinal. Optionally, pouch 160 may be a porous linen bag that operates like a tea bag in allowing water to seep into the bag and dissipate the cleaning mixture. The sulfamic acid mixture may include a substrate such as polyethylene glycol (PEG) to substantially slow the dissipation of the sulfamic acid mixture. This timed release action extends the life of the refill cartridge 108 so that it may continue to release water with sulfamic acid therein for an extended period of time – usually from 30 to 60 days, before needing to be replaced. Fragrance beads (not shown) may also be included in pouch 160. The fragrance beads help ensure that the standing water in the bottom of the urinal does not have an unpleasant odor.

The front housing 112 and rear housing 113 may be made from polypropylene (PP) plastic, a very light weight material. These two pieces may be vacuum molded to form the main components in the refill cartridge 108. As previously mentioned, the sulfamic acid mixture may be made up of sulfamic acid and polyethylene glycol (PEG). Other materials known in the art may also be used. This chemical mixture may be pressed into blocks that weight between 90-100 grams. The chemical mixture may be designed to slowly release its mixture to clean calcium deposits and other buildup in a urinal over an extended period of time. The chemical mixture may also breakdown calcium build up in the urinal pipes. Thus, the device of the present invention removes odor-causing substances in the urinal and urinal pipes, as well as preventing clogging of the urinal pipes.

Looking now at Figure 8, the refill cartridge 108 is snapped into place in the mounting bracket 102, as discussed above to form the urinal cleaner 100. Then, as shown in Figure 9, the urinal cleaner unit 100 is disposed in a urinal 200 by moving cleaner unit 100 upward, as shown by arrows 202 and 204, until barbed arms 104 and 106 come into contact with water holes 210. With some pressure the barbs 105 and 107 of arms 104 and 106 are forced into water holes 210 to hold the urinal cleaner 100 in place in urinal 200.

As shown in Figure 10, with the urinal cleaner 100 positioned in the urinal 200, each time the urinal 200 is flushed, water is released from holes 210 (not shown here) and some of the water enters the two water holes 152 and 153 (not shown here) cut into the top of the rear housing 113 so that water flows into the chemical chamber 150. The bottom hole 154 in rear housing 113 allows the water in chemical chamber 150 to be released. The released chemical-laden water then flows down the urinal walls 216, cleaning as it goes. The lower lip 140 (Figure 3) directs the water toward the urinal wall to avoid splashing on a user. The fragrance beads in the chemical chamber 150 also release a pleasant fragrance to offset unpleasant odors from the urinal. Additional fragrance is slowly released from the fragrance cap 110 in front housing 112.

The refill cartridge 108 and the mounting bracket 102 have tabs 130 and 132 (shown in Figure 2) that enables the separation of refill cartridge 108 from mounting bracket 102, so that a user may remove a spent refill cartridge 108 and install a new refill cartridge in the mounting bracket 102. The barbed arms 104 and 106 maintain the mounting bracket 102 in the urinal until the urinal cleaning unit 100 is no longer needed. By applying downward pressure, the barbs 105 and 107 of barbed arms 104 and 106 are broken or otherwise yield to the downward pressure to enable the release of the mounting bracket 102.

The present invention, as described in the foregoing embodiments, provides a number of advantages over the existing prior art. The cleaning and deodorizing unit disclosed herein is light and easy to manufacture and ship. Its structure makes it easy to install and remove from urinals. The refill cartridge disclosed herein is easy and simple to install and remove. The placement of the cleaning unit insures comprehensive coverage and cleaning of a urinal unit. The structure of the refill housing enables slow and steady usage of the chemicals therein so that the life of the refill is substantially extended. The fragrance unit is also structured for slow steady release over a long period of time. The simple and inexpensive structure of the cleaning and deodorizing unit make the system inexpensive and environmentally friendly.

Various changes in materials and components can be made within the spirit and coverage of the present invention. The shapes of the mounting bracket, refill cartridge, and fragrance cap are not critical so long as they mate to each other as shown in the illustrative embodiment. The cleaning agents used with the present invention may be some other suitable chemical beside sulfamic acid, such as citric acid, phosphoric acid,

muriatic acid, and the like. The front and back housings of the refill cartridge and/or the mounting bracket, may be manufactured from some materials other than as described herein. The fragrances may be applied by other units or components and may be made of other suitable chemicals besides those described herein.

5 It will be understood that the invention may be embodied in other specific forms by one of ordinary skill in the art without departing from the spirit, characteristics or coverage of the present invention. The present example and embodiment are to be considered to be illustrative and not restrictive, and the invention is not intended to be limited to the details of the described embodiments. Rather, the invention is defined by
10 the claims, and as broadly as the prior art will permit.

CLAIMS

The subject matter claimed is:

1. A urinal cleaning unit for cleaning a urinal having periodic water flow therethrough comprising:
 - 5 (a) a mounting device for attaching the urinal clean unit to a urinal;
 - (b) a disposable unit adapted for releasably attaching to the mounting device;
 - (c) a chamber in the disposable unit for containing a cleaning agent adapted to intercept a portion of the water flow.
- 10 2. The urinal cleaning unit of claim 1, wherein the mounting device comprises connecting apparatus to connect to a water outlet to the urinal.
3. The urinal cleaning unit of claim 2, wherein the connecting apparatus comprises a barbed arm connected to the urinal cleaning unit to attach to the water outlet.
- 15 4. The urinal cleaning unit of claim 1, wherein the disposable unit comprises a chamber housing having the chamber therein and having openings in the chamber to intercept the portion of the water flow.
 5. The urinal cleaning unit of claim 4, wherein the openings comprise a first opening near one end of the chamber is receive the portion of the water flow and a
20 second opening near another end of the chamber to emit some of the portion of the water flow after it has flowed through the chamber.
 6. The urinal cleaning unit of claim 1 further comprising a porous container disposed in the chamber for containing the cleaning agent.
 7. The urinal cleaning unit of claim 5, wherein the porous container is
25 configured to enable the portion of the water flow to seep into and out of the container.
 8. The urinal cleaner of claim 1, wherein chamber is adapted to mix the portion of the water flow with the cleaning agent and release a mixture of water and cleaning agent into the urinal.
 9. The urinal cleaning unit of claim 1 further comprising a second housing
30 attached to the chamber housing for releasing a fragrance in air surrounding the urinal.
 10. The urinal cleaning unit of claim 1, wherein the cleaning agent is sulfamic acid.

11. A method of cleaning a urinal having periodic water flow therethrough comprising:
- (a) mounting a disposable unit to a urinal;
 - (b) enabling a portion of the water flow to flow through the
5 disposable unit;
 - (c) mixing the portion of the water flow with a cleaning agent in the disposable unit to form a mixture of water and cleaning agent; and
 - (d) releasing the mixture of water and cleaning agent to the urinal.
12. The urinal cleaning method of claim 11, wherein the mounting step
10 comprises connecting the disposable unit to the periodic water flow to enable water to flow therethrough.
13. The urinal cleaning method of claim 11, wherein the enabling step comprises connecting the portion of water flow to a chamber in the disposable unit, the chamber having openings therein to intercept the portion of the water flow.
14. The urinal cleaning method of claim 13, wherein the connecting step
15 comprises running water into a first opening near one end of the chamber to receive the portion of the water flow and out of a second opening near another end of the chamber to emit some of the portion of the water flow after it has flowed through the chamber.
15. The urinal cleaning method of claim 11 further comprising running the
20 portion of water through a porous container disposed in the chamber for containing the cleaning agent.
16. The urinal cleaning method of claim 11, further comprising running the
portion of water through a chamber adapted to mix the portion of the water flow with the cleaning agent.
17. The urinal cleaning method of claim 16, further comprising releasing the
25 mixture of water and cleaning agent into the urinal.
18. The urinal cleaning method of claim 11 further comprising releasing a fragrance from the disposable unit in air surrounding the urinal.
19. The urinal cleaning method of claim 22 further comprising causing the
30 mixture of cleaning agent and water to flow from the urinal into associated urinal drain pipes to remove unpleasant smelling buildup and prevent clogging of the urinal drain pipes.

20. The urinal cleaning method of claim 11, wherein the cleaning agent is sulfamic acid.

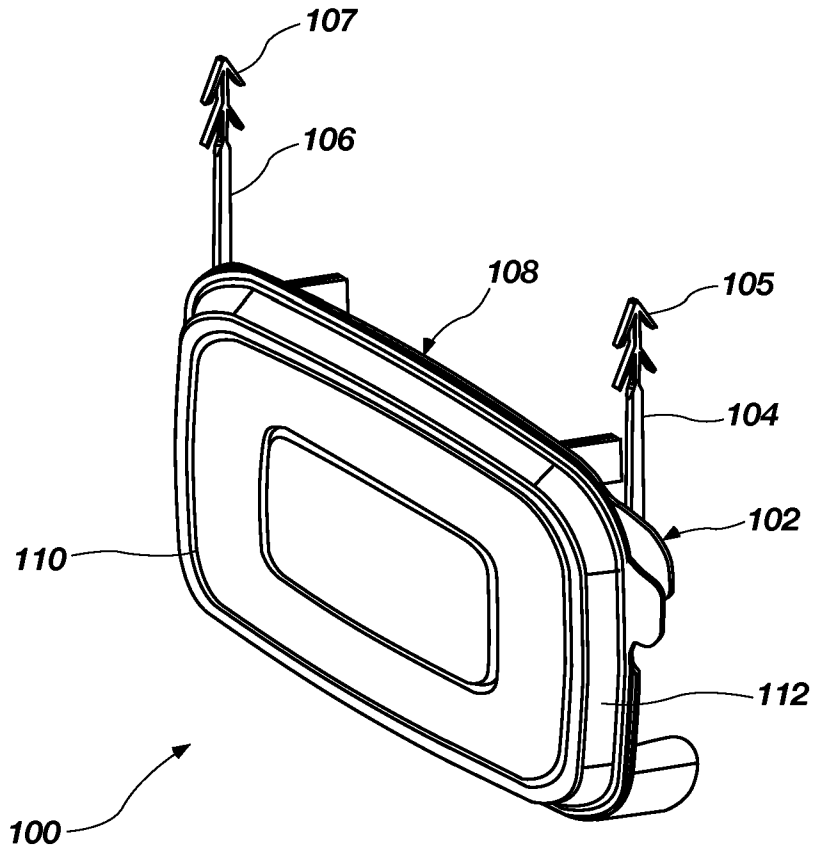

FIG. 1

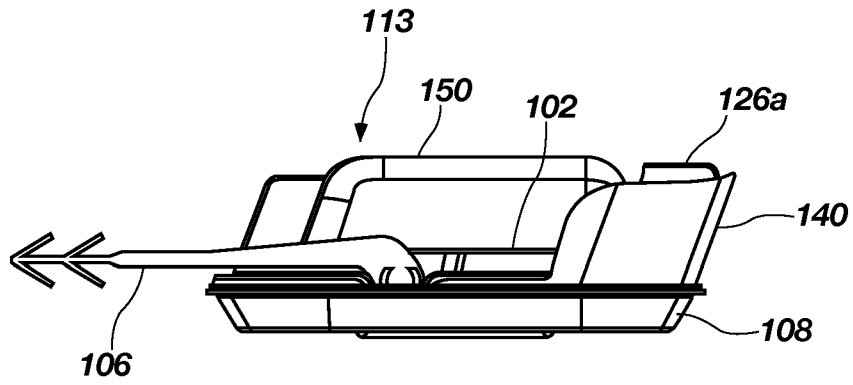

FIG. 3

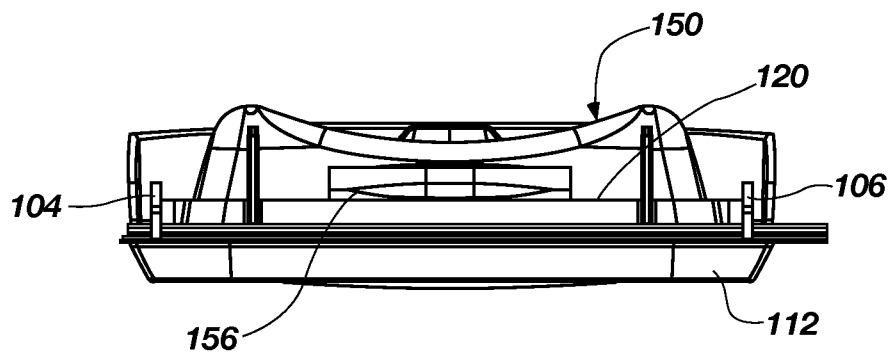

FIG. 4

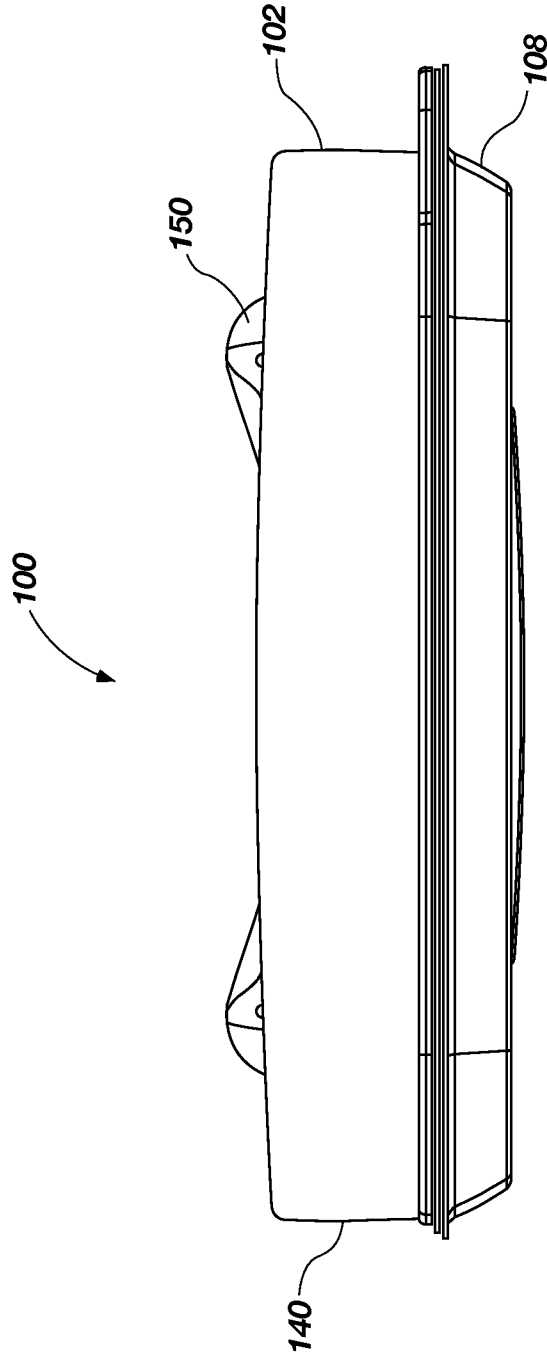

FIG. 4A

5/10

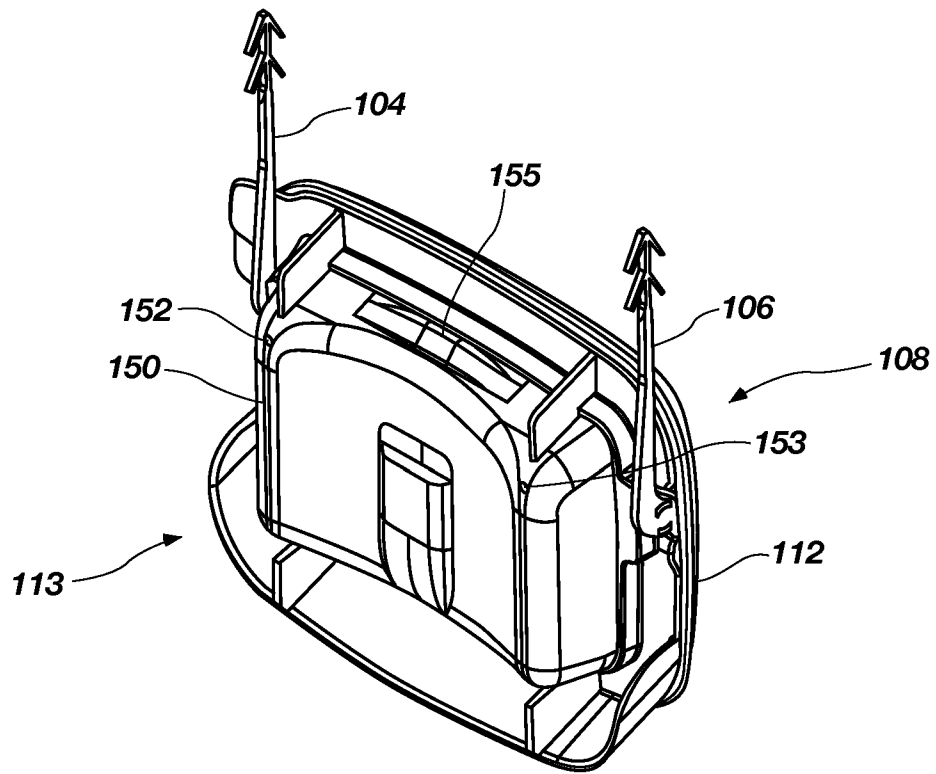

FIG. 5

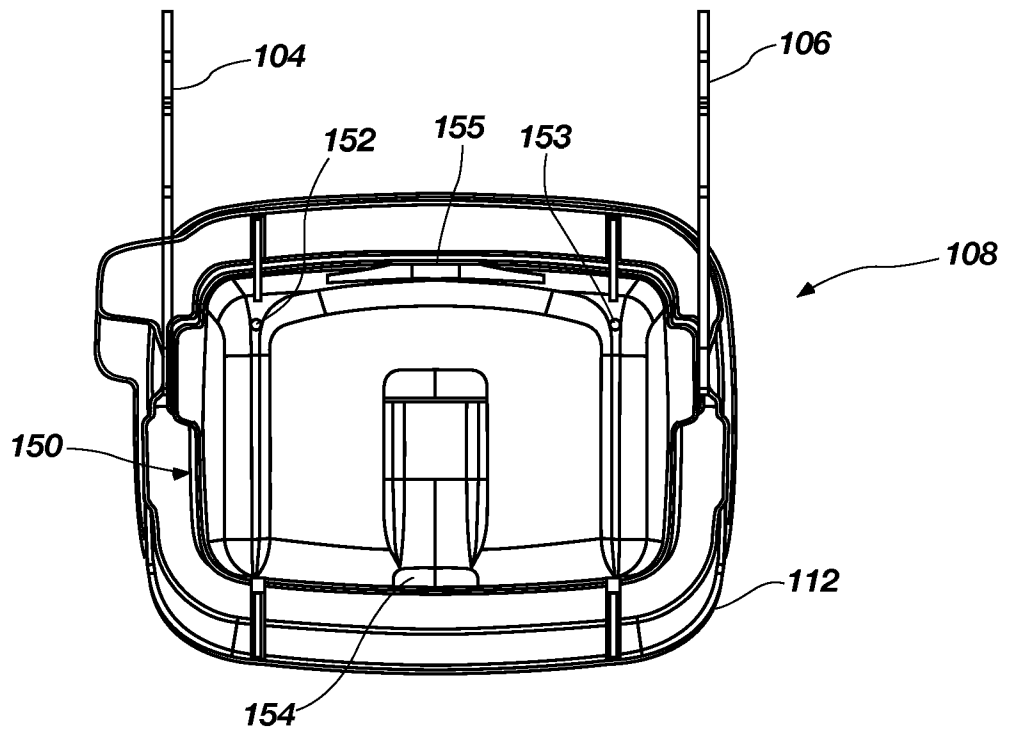

FIG. 6

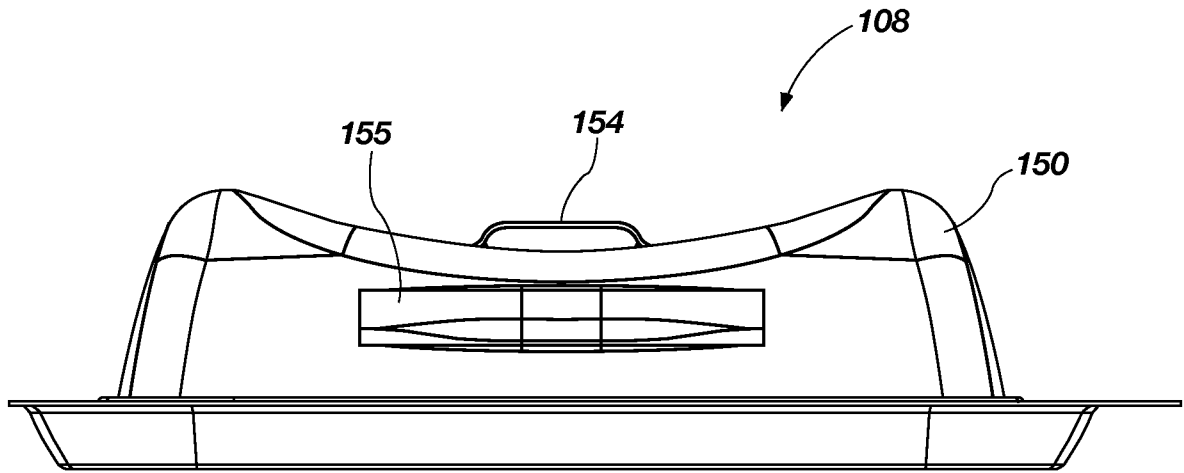

FIG. 6A

7/10

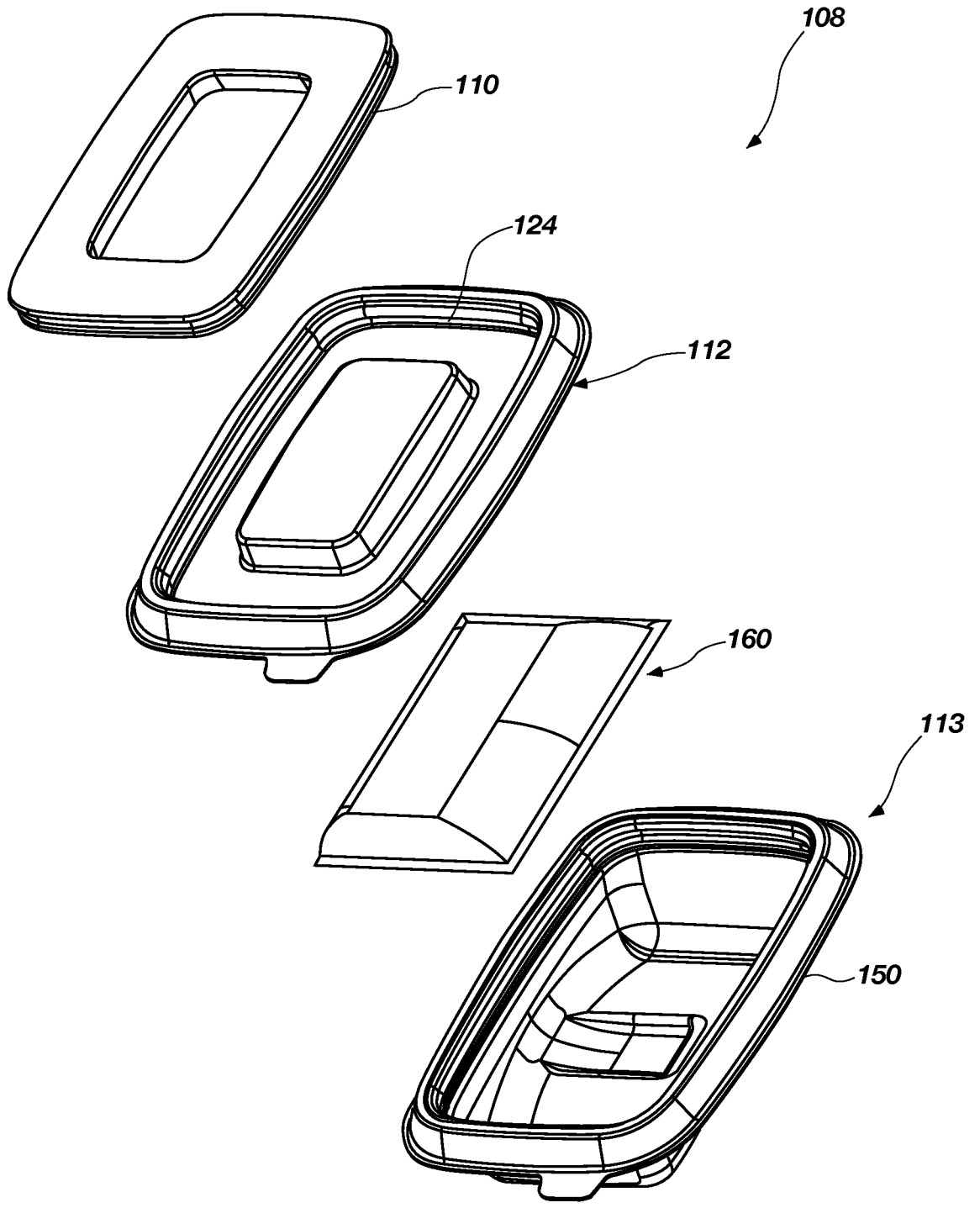

FIG. 7

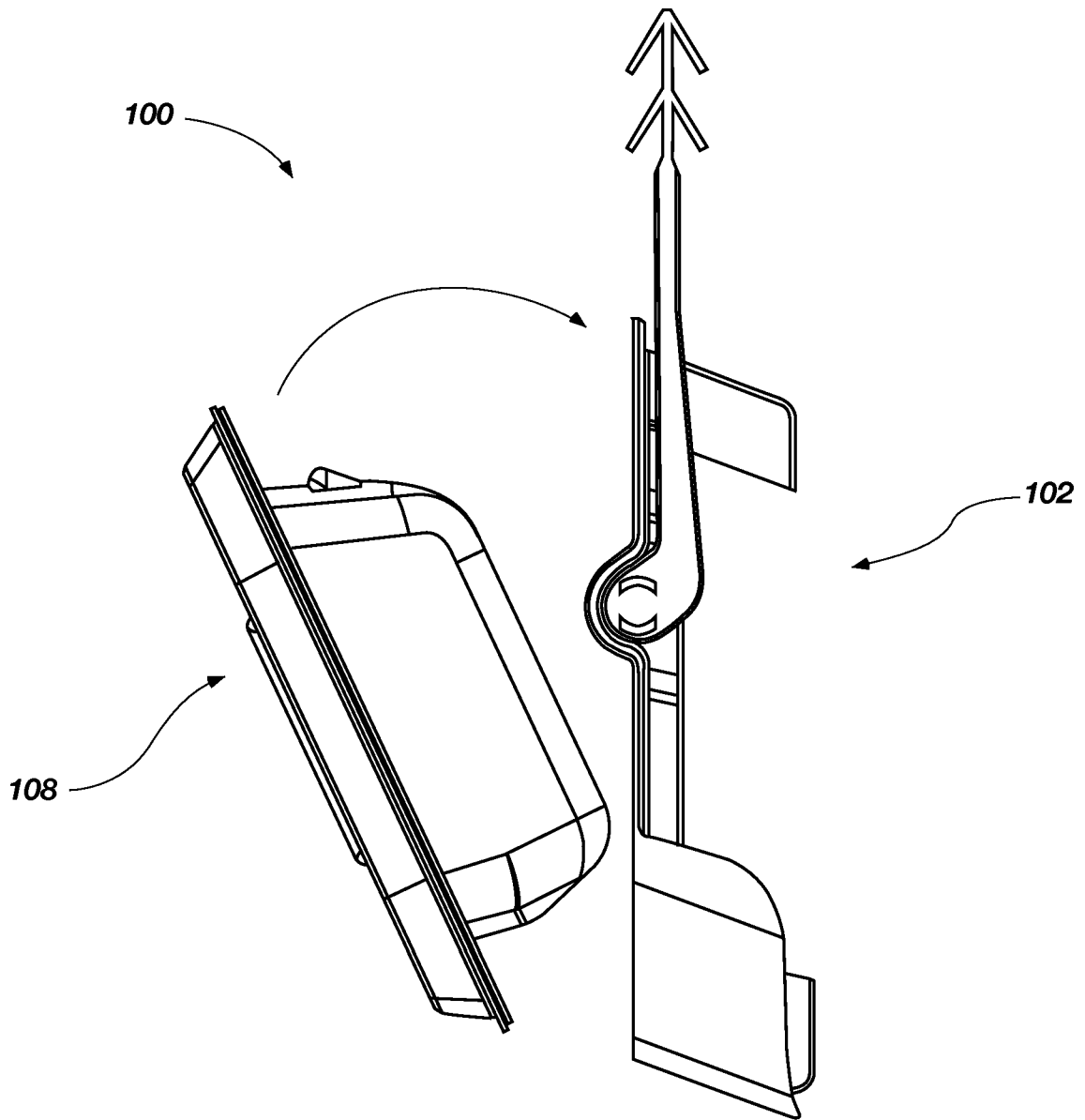

FIG. 8

9/10

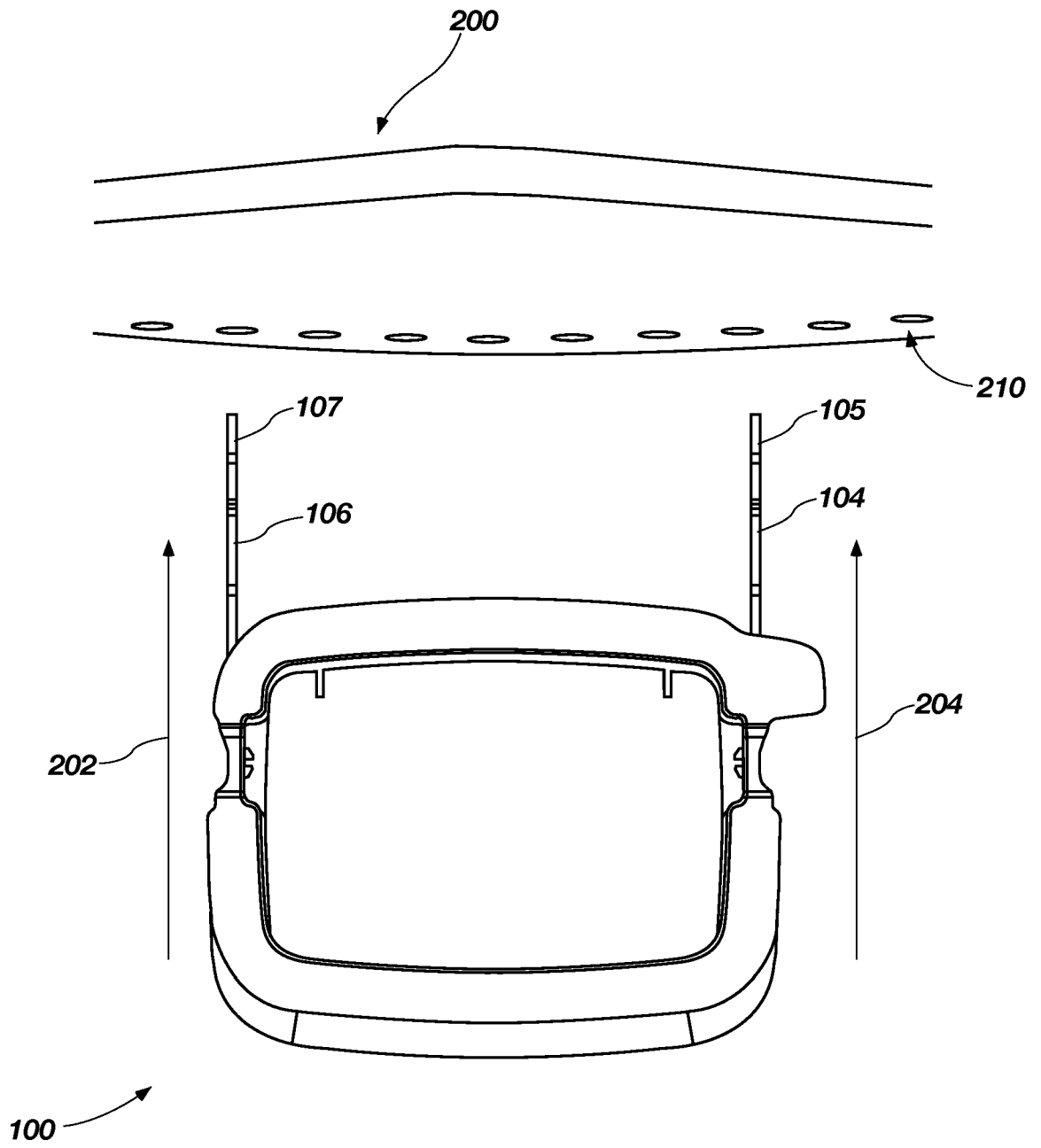

FIG. 9

10/10

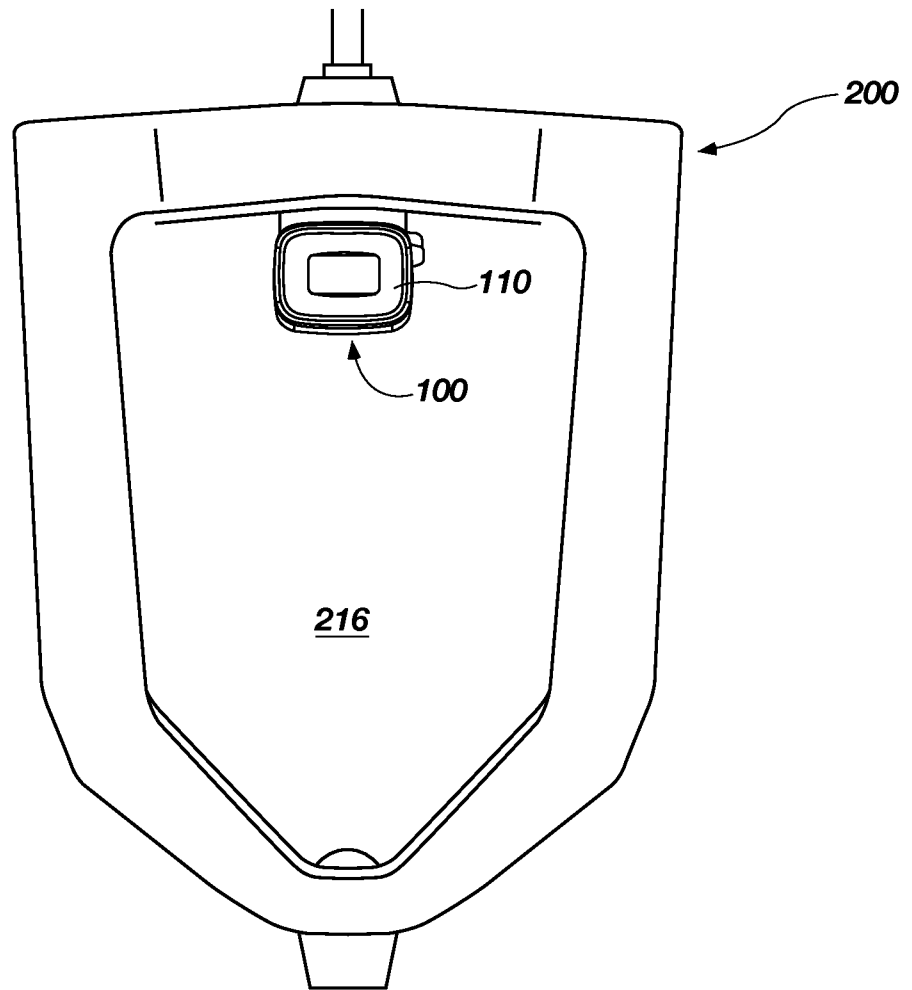

FIG. 10