

(19) World Intellectual Property Organization
International Bureau



(43) International Publication Date
25 October 2001 (25.10.2001)

PCT

(10) International Publication Number
WO 01/80024 A2

- (51) International Patent Classification⁷: **G06F 13/00**
- (21) International Application Number: PCT/US01/12384
- (22) International Filing Date: 16 April 2001 (16.04.2001)
- (25) Filing Language: English
- (26) Publication Language: English
- (30) Priority Data:
60/197,490 17 April 2000 (17.04.2000) US
- (71) Applicant: **CIRCADENCE CORPORATION** [US/US];
Suite 101, 4888 Pearl East Circle, Boulder, CO 80301 (US).
- (72) Inventors: **VANGE, Mark**; 2800 1 Adelaide Street East,
Toronto, Ontario M5C 2V9 (CA). **PLUMB, Marc**; 2800-1
Adelaide Street East, Toronto, Ontario M5C 2V9 (CA).
WILSON, Glenn, Sydney; #240-137 Roncesvalles Av-
enue, Toronto, Ontario M6R 2LS (CA). **KOUTS, Michael**;
42 Rameau Drive, Toronto, Ontario L7P 4Y7 (CA).
- (74) Agents: **BURTON, Carol, W.** et al.; Hogan & Hartson
LLP, Suite 1500, 1200 17th Street, Denver, CO 80202 (US).
- (81) Designated States (*national*): AE, AG, AL, AM, AT, AU,
AZ, BA, BB, BG, BR, BY, BZ, CA, CH, CN, CO, CR, CU,
CZ, DE, DK, DM, DZ, EE, ES, FI, GB, GD, GE, GH, GM,
HR, HU, ID, IL, IN, IS, JP, KE, KG, KP, KR, KZ, LC, LK,
LR, LS, LT, LU, LV, MA, MD, MG, MK, MN, MW, MX,
MZ, NO, NZ, PL, PT, RO, RU, SD, SE, SG, SI, SK, SL,
TJ, TM, TR, TT, TZ, UA, UG, UZ, VN, YU, ZA, ZW.
- (84) Designated States (*regional*): ARIPO patent (GH, GM,
KE, LS, MW, MZ, SD, SL, SZ, TZ, UG, ZW), Eurasian
patent (AM, AZ, BY, KG, KZ, MD, RU, TJ, TM), European
patent (AT, BE, CH, CY, DE, DK, ES, FI, FR, GB, GR, IE,
IT, LU, MC, NL, PT, SE, TR), OAPI patent (BF, BJ, CF,
CG, CI, CM, GA, GN, GW, ML, MR, NE, SN, TD, TG).
- Published:**
— *without international search report and to be republished
upon receipt of that report*
- For two-letter codes and other abbreviations, refer to the "Guid-
ance Notes on Codes and Abbreviations" appearing at the begin-
ning of each regular issue of the PCT Gazette.*



WO 01/80024 A2

(54) Title: CONDUCTOR GATEWAY BUFFER PRIORITIZATION

(57) Abstract: A method for transmitting packets from a network computer onto a network. At least two data sets are received. A priority value is determined for each of the at least two data sets. A composite data set is composed comprising portions of the at least two data sets such that an amount of data from each of the data sets within the composite data set is based upon relative priorities between each of the at least two data sets. The composite data set is transmitted onto the network.

CONDUCTOR GATEWAY BUFFER PRIORITIZATION

BACKGROUND OF THE INVENTION

5 Field of the Invention.

The present invention relates, in general, to a system and method for prioritizing information across a network, and, more particularly, to software, systems and methods for prioritizing information transmitted across a public network, such as the Internet.

10 Relevant Background.

Increasingly, business data processing systems, entertainment systems, and personal communications systems are implemented by computers across networks that are interconnected by internetworks (e.g., the Internet). The Internet is rapidly emerging as the preferred system for
15 *distributing and exchanging data.* Data exchanges support applications including electronic commerce (e-commerce), broadcast and multicast messaging, videoconferencing, gaming, and the like.

The Internet is a collection of disparate computers and networks coupled together by a web of interconnections using standardized
20 communications protocols. The Internet is characterized by its vast reach as a result of its wide and increasing availability and easy access protocols. Unfortunately, the heterogeneous nature of the Internet results in variable bandwidth and quality of service between points. The latency and reliability of data transport is largely determined by the total amount of traffic on the
25 Internet and so varies wildly seasonally and throughout the day. Other factors that affect quality of service include equipment outages and line degradation that force packets to be rerouted, damaged and/or dropped. Also, routing software and hardware limitations within the Internet infrastructure may create

bandwidth bottlenecks even when the mechanisms are operating within specifications.

Internet transport protocols do not effectively discriminate between users. Data packets are passed between routers and switches that make up
5 the Internet fabric based on the hardware's instantaneous view of the best path between source and destination nodes specified in the packet. Because each packet may take a different path, the latency of a packet cannot be guaranteed and, in practice, varies significantly. Although Internet infrastructure components have been developed that allow for the provision of
10 some level of packet prioritization, these components have limited deployment. Because of this limited deployment, web site operators cannot depend on prioritization services to be available throughout the network, and in reality can only depend on a small portion of the Internet being served by such components. Moreover, components that are available may require
15 modifications to the web site to operate. Hence, in large part data packets are routed through the Internet without any prioritization based on content.

Prioritization has not been a major issue with conventional networks such as local area networks (LANs) and wide area networks (WANs) that primarily handle well characterized data traffic between a known and
20 controlled set of network nodes. In such environments, the network administrators are in control of network traffic and can effectively police bandwidth consumption, resource availability and distribution, and other variables that affect quality of service. In contrast, public networks such as the Internet, involve data traffic that is out of control of any particular network
25 administrator. However, because of their wide availability, there is an increasing desire to provide network services using public networks, such as the Internet. At the same time, there is an increasing demand for network applications that cannot tolerate high and variable latency. This situation is complicated when the application is to be run over the Internet where latency
30 and variability in latency are many times greater than in LAN and WAN environments.

A particular need exists in environments that involve multiple users accessing a network resource such as a web server. Examples include broadcast, multicast and videoconferencing as well as most e-commerce applications. In these applications, it is important to maintain a reliable
5 connection so that the server and clients remain synchronized and information is not lost.

In e-commerce applications, it is important to provide a satisfying buying experience that leads to a purchase transaction. To provide this high level of service, a web site operator must ensure that data is delivered to the
10 customer in the most usable and efficient fashion. Also, the web site operator must ensure that critical data received from the customer is handled with priority.

Because the few techniques that provide traffic prioritization are not widely distributed in public networks, the e-commerce site owner has had little
15 or no control over the transport mechanisms through the Internet that affect the latency and quality of service. This is akin to a retailer being forced to deal with a customer by shouting across the street, never certain how often what was said must be repeated, and knowing that during rush hour communication would be nearly impossible. While efforts are continually
20 being made to increase the capacity and quality of service afforded by the Internet, it is contemplated that congestion will always impact the ability to predictably and reliably offer a specified level of service. Moreover, the change in the demand for bandwidth increases at a greater rate than does the change in bandwidth supply, ensuring that congestion will continue to be
25 an issue into the foreseeable future. A need exists for a system to exchange data over the Internet that provides a high quality of service even during periods of congestion.

Many e-commerce transactions are abandoned by the user because system performance degradation frustrates the purchaser before the
30 transaction is consummated. While a data exchange that is abandoned while a customer is merely browsing through a catalog may be tolerable,

abandonment when the customer is just a few clicks away from a purchase is highly undesirable. However, existing Internet transport mechanisms and systems do not allow the e-commerce site owner any effective ability to offer differentiated service levels to, the "just browsing" and the "about-to-buy" customers. In fact, the vagaries of the Internet may lead to the casual browser receiving a higher quality of service while the about to buy customer becomes frustrated and abandons the transaction.

SUMMARY OF THE INVENTION

In accordance with this invention, the above problems are addressed by prioritizing sets of information transmitted across a network. A set of information comprises, for example, one or more data packets related to a particular user, a particular session, a particular server, or particular resources within a server. The effective priority of a set of information is used to provide differential levels of service to the sets of information. For example, the effective priority determines the order in which the associated information is transmitted and/or other characteristics associated with the information, such as connection reliability.

In one embodiment, the set of information is a packet, and the packets are prioritized upon receipt by an intermediary network computer. The packets are prioritized by computing the effective priority based upon a plurality of priority factors. The priority factors are determined from priority parameters extracted from the data packets themselves (i.e., by parsing the data packets and analyzing the parsed data) in a particular implementation. In another implementation at least some of the priority parameters are obtained from a content server 210 associated with the data packet. The intermediary network computer transmits packets based on the effective priority associated with each packet.

Priority information includes priority parameters and priority values. While priority values are ultimately used to compute the effective priority, the priority values are communicated between entities as priority parameters of

the data packets being transmitted. A priority value may be directly defined by the associated priority parameter (e.g., the parameter has a value equal to the priority value). Alternatively, the priority parameter may indirectly define the associated priority value (e.g., the parameter specifies a URL and the URL is, in turn, associated with a priority value). Priority information also includes weighting algorithms used to compute an effective priority from a plurality of priority values.

Priority information is characterized by type and value. Generally, priority types include user priority and content priority. User priority refers, for example, to values and parameters such as user identification, user address, session identification, and similar information associated with a particular user or group of users. In a particular embodiment, user priority information includes client-designed user priority (CAP), client-specific user priority (CSUP), and global user priority (GUP) information. Content priority information refers, for example, content identification, content type, URL, server address, and similar information associated with the content being communicated by a particular data packet. Content generally refers to any services or data provided by a network resource and may include web pages, application services, database services, file services, news services, mail services, and the like.

In one embodiment, priority parameters are transmitted with the sets of information to an intermediate computing device that performs the prioritization function. The intermediate entity determines priority values from the priority parameters, and applies the weighting algorithms to determine an effective priority value. In a particular example, weighting algorithms are transmitted via an out-of-band management system.

BRIEF DESCRIPTION OF THE DRAWINGS

FIG. 1 illustrates a general distributed computing environment in which the present invention is implemented;

Fig. 2 shows in block-diagram form significant components of a system in accordance with the present invention;

Fig. 3 shows a domain name system used in an implementation of the present invention;

5 Fig. 4 shows front-end server components of Fig. 2 in greater detail;

Fig. 5 shows back-end server components of Fig. 2 in greater detail;

Fig. 6 shows a high-level flow chart representation of an information prioritization function;

10 Fig. 7 a flow diagram of activities involved in prioritization in accordance with an embodiment of the present invention; and

Fig. 8 illustrates relationships and data exchanges between various entities in accordance with the present invention.

DETAILED DESCRIPTION OF THE PREFERRED EMBODIMENTS

15 The present invention is illustrated and described in terms of a distributed computing environment such as an enterprise computing system using public communication channels such as the Internet. However, an important feature of the present invention is that it is readily scaled upwardly and downwardly to meet the needs of a particular application. Accordingly, unless specified to the contrary, the present invention is applicable to
20 significantly larger, more complex network environments as well as small network environments such as LAN systems.

FIG. 1 shows an exemplary computing environment 100 in which the present invention may be implemented. Environment 100 includes a plurality of local networks such as Ethernet network 102, FDDI network 103 and
25 Token Ring network 104. Essentially, a number of computing devices and groups of devices are interconnected through a network 101. For example, local networks 102, 103 and 104 are each coupled to network 101 through routers 109. LANs 102, 103 and 104 may be implemented using any available topology and may implement one or more server technologies

including, for example a UNIX, Novell, or Windows NT networks, and/or peer-to-peer type networking. Each network will include distributed storage implemented in each device and typically includes some mass storage device coupled to or managed by a server computer. Network 101 comprises, for
5 example, a public network, such as the Internet, or another network mechanism, such as a fibre channel fabric or conventional WAN technologies.

Local networks 102, 103 and 104 include one or more network appliances 107. One or more network appliances 107 may be configured as
10 an application and/or file server. Each local network 102, 103 and 104 may include a number of shared devices (not shown) such as printers, file servers, mass storage and the like. Similarly, devices 111 may be shared through network 101 to provide application and file services, directory services, printing, storage, and the like. Routers 109 which exist throughout network
15 101 as well as at the edge of network 101 as shown in FIG. 1, provide a physical connection between the various devices through network 101. Routers 109 may implement desired access and security protocols to manage access through network 101.

Network appliances 107 may also couple to network 101 through
20 public switched telephone network (PSTN) 108 using copper or wireless connection technology. In a typical environment, an Internet service provider 106 supports a connection to network 101 as well as PSTN 108 connections to network appliances 107.

Network appliances 107 may be implemented as any kind of network
25 appliance having sufficient computational function to execute software needed to establish and use a connection to network 101. Network appliances 107 may comprise workstation and personal computer hardware executing commercial operating systems such as Unix variants, Microsoft Windows, Macintosh OS, and the like. At the same time, some appliances
30 107 comprise portable or handheld devices such as personal digital assistants and cell phones executing operating system software such as

PalmOS, WindowsCE, EPOCOS and the like. Moreover, the present invention is readily extended to network devices such as office equipment, vehicles, and personal communicators that occasionally connect through network 101.

5 Each of the devices shown in FIG. 1 may include memory, mass storage, and a degree of data processing capability sufficient to manage their connection to network 101. The computer program devices in accordance with the present invention are implemented in the memory of the various devices shown in FIG. 1 and enabled by the data processing capability of the
10 devices shown in FIG. 1. In addition to local memory and storage associated with each device, it is often desirable to provide one or more locations of shared storage such as disk farm (not shown) that provides mass storage capacity beyond what an individual device can efficiently use and manage. Selected components of the present invention may be stored in or
15 implemented in shared mass storage.

 The preferred embodiments of the present invention involve one or more intermediary computers (e.g., front-end 201 and back-end 203) located between a client 205 and a server 210 shown in Fig. 2. The present invention operates in a manner akin to a private network 200 implemented within the
20 Internet infrastructure. Private network 200 expedites and prioritizes communications between a client 205 and a web site 210. In the specific examples herein client 205 comprises a network-enabled graphical user interface such as a web browser. However, the present invention is readily extended to client software other than conventional web browser software.
25 Any client application that can access a standard or proprietary user level protocol for network access is a suitable equivalent. Examples include client applications that act as front-ends for file transfer protocol (FTP) services, Voice over Internet Protocol (VoIP) services, network news protocol (NNTP) services, multi-purpose Internet mail extensions (MIME) services, post office
30 protocol (POP) services, simple mail transfer protocol (SMTP) services, as well as Telnet services. In addition to network protocols, the client application

may serve as a front-end for a network application such as a database management system (DBMS) in which case the client application generates query language (e.g., structured query language or "SQL") messages. In wireless appliances, a client application functions as a front-end to a wireless application protocol (WAP) service.

For convenience, the term "web site" is used interchangeably with "web server" in the description herein, although it should be understood that a web site comprises a collection of content, programs and processes implemented on one or more web servers. A web server is a specific example of a network server or network resource that provides services (e.g., data or application services) in response to received requests. A web site is owned by the content provider such as an e-commerce vendor, whereas a web server refers to set of programs running on one or more machines coupled to an Internet node. The web site 210 may be hosted on the site owner's own web server, or hosted on a web server owned by a third party. A web hosting center is an entity that implements one or more web sites on one or more web servers using shared hardware and software resources across the multiple web sites. In a typical web infrastructure, there are many web browsers, each of which has a TCP connection to the web server in which a particular web site is implemented. The preferred implementation of the present invention adds two components to a conventional infrastructure: a front-end 201 and back-end 203. Front-end 201 and back-end 203 are coupled by a managed data communication link 202 that forms, in essence, a private network.

Front-end mechanism 201 serves as an access point for client-side communications. Front-end 201 implements a gateway that functions as an intermediate computer to prioritize data traffic destined for the web server(s) implementing web site 210. From the perspective of client 205, front-end 201 appears to be the web site 210. Front-end 201 comprises, for example, a computer that sits "close" to clients 205. By "close", it is meant that the average latency associated with a connection between a client 205 and a

front-end 201 is less than the average latency associated with a connection between a client 205 and a web site 210. Desirably, front-end computers have as fast a connection as possible to the clients 205. For example, the fastest available connection may be implemented in point of presence (POP) of an Internet service provider (ISP) 106 used by a particular client 205. However, the placement of the front-ends 201 can limit the number of browsers that can use them. Because of this, in some applications it is more practical to place one front-end computer in such a way that several POPs can connect to it. Greater distance between front-end 201 and clients 205 may be desirable in some applications as this distance will allow for selection amongst a greater number front-ends 201 and thereby provide significantly different routes to a particular back-end 203. This may offer benefits when particular routes and/or front-ends become congested or otherwise unavailable.

Transport mechanism 202 is implemented by cooperative actions of the front-end 201 and back-end 203. Back-end 203 processes and directs data communication to and from web site 210. Transport mechanism 202 communicates data packets using a proprietary protocol over the public Internet infrastructure in the particular example. Hence, the present invention does not require heavy infrastructure investments and automatically benefits from improvements implemented in the general-purpose network 101. Unlike the general purpose Internet, front-end 201 and back-end 203 are programmably assigned to serve accesses to a particular web site 210 at any given time.

It is contemplated that any number of front-end and back-end mechanisms may be implemented cooperatively to support the desired level of service required by the web site owner. The present invention implements a many-to-many mapping of front-ends to back-ends. Because the front-end to back-end mappings can be dynamically changed, a fixed hardware infrastructure can be logically reconfigured to map more or fewer front-ends to more or fewer back-ends and web sites or servers as needed.

Front-end 201 together with back-end 203 function to reduce traffic across the Transport morphing protocol™ (TMP™) link 202 and to improve response time for selected browsers. Transport morphing protocol and TMP are trademarks of Circadence Corporation in the United States and other countries. In addition to being prioritized, traffic across the TMP link 202 is reduced by compressing data and serving browser requests from cache for fast retrieval. Also, the blending of request datagrams results in fewer request:acknowledge pairs across the TMP link 202 as compared to the number required to send the packets individually between front-end 201 and back-end 203. This action reduces the overhead associated with transporting a given amount of data, although conventional request:acknowledge traffic is still performed on the links coupling the front-end 201 to client 205 and back-end 203 to a web server. Moreover, resend traffic is significantly reduced further reducing the traffic.

In one embodiment, front-end 201 and back-end 203 are closely coupled to the Internet backbone. This means they have high bandwidth connections, can expect fewer hops, and have more predictable packet transit time than could be expected from a general-purpose connection. Although it is desirable to have low latency connections between front-ends 201 and back-ends 203, a particular strength of the present invention is its ability to deal with latency by enabling efficient transport and traffic prioritization. Hence, in other embodiments front-end 201 and/or back-end 203 may be located farther from the Internet backbone and closer to clients 205 and/or web servers 210. Such an implementation reduces the number of hops required to reach a front-end 201 while increasing the number of hops within the TMP link 202 thereby yielding control over more of the transport path to the management mechanisms of the present invention.

Clients 205 no longer conduct all data transactions directly with the web server 210. Instead, clients 205 conduct some and preferably a majority of transactions with front-ends 201, which implement the functions of web server 210. Client data is then sent, using TMP link 202, to the back-end 203

and then to the web server 210. Running multiple clients 205 over one large connection provides several advantages:

5 Since all client data is mixed, each client can be assigned a priority. Higher priority clients, or clients requesting higher priority data, can be given preferential access to network resources so they receive access to the channel sooner while ensuring low-priority clients receive sufficient service to meet their needs.

10 The large connection between a front-end 201 and back-end 203 can be permanently maintained, shortening the many TCP/IP connection sequences normally required for many clients connecting and disconnecting.

15 Using a proprietary protocol allows front-end 201 implement a prioritization function to selectively send packets according to effective priority values associated with the packets and to improve data throughput and makes better use of existing bandwidth during periods when the network is congested.

20 A particular advantage of the architecture shown in FIG. 2 is that it is readily scaled. Any number of client machines 205 may be supported. In a similar manner, a web site owner may choose to implement a site using multiple web servers 210 that are co-located or distributed throughout network 101. To avoid congestion, additional front-ends 201 may be implemented or assigned to particular web sites. Each front-end 201 is dynamically re-configurable by updating address parameters to serve particular web sites. Client traffic is dynamically directed to available front-ends 201 to provide load balancing. Hence, when quality of service drops because of a large number of client accesses, an additional front-end 201 can be assigned to the web site and subsequent client requests directed to the newly assigned front-end 201 to distribute traffic across a broader base.

30 In the particular examples, front-end to back-end assignment is implemented by a front-end manager component 207 that communicates with multiple front-ends 201 to provide administrative and configuration information

to front-ends 201. Each front-end 201 includes data structures for storing the configuration information, including information identifying the IP addresses of web servers 210 to which they are currently assigned. Other administrative and configuration information stored in front-end 201 may include information for prioritizing data from and to particular clients, quality of service information, and the like.

Similarly, additional back-ends 203 can be assigned to a web site to handle increased traffic. Back-end manager component 209 couples to one or more back-ends 203 to provide centralized administration and configuration service. Back-ends 203 include data structures to hold current configuration state, quality of service information and the like. In the particular examples front-end manager 207 and back-end manager 209 serve multiple web sites 210 and so are able to manipulate the number of front-ends and back-ends assigned to each web site 210 by updating this configuration information. When the congestion for the site subsides, the front-end 201 and back-end 203 can be reassigned to other, busier web sites.

In the case of web-based environments, front-end 201 is implemented using custom or off-the-shelf web server software. Alternatively, front-end 201 may be implemented as a server process running in a network component such as a router. Front-end 201 is readily extended to support other, non-web-based protocols, however, and may support multiple protocols for varieties of client traffic. Front-end 201 processes the data traffic it receives, regardless of the protocol of that traffic, to a form suitable for transport by TMP 202 to a back-end 203. Hence, most of the functionality implemented by front-end 201 is independent of the protocol or format of the data received from a client 205. Hence, although the discussion of the exemplary embodiments herein relates primarily to front-end 201 implemented as a web server, it should be noted that, unless specified to the contrary, web-based traffic management and protocols are merely examples and not a limitation of the present invention.

In order for a client 205 to obtain service from a front-end 201, it must first be directed to a front-end 201 that can provide the desired service. Preferably, client 205 does not need to be aware of the location of front-end 201, and initiates all transactions as if it were contacting the originating server 210. FIG. 3 illustrates a domain name server (DNS) redirection mechanism that illustrates how a client 205 is connected to a front-end 201. The DNS systems is defined in a variety of Internet Engineering Task Force (IETF) documents such as RFC0883, RFC 1034 and RFC 1035 which are incorporated by reference herein. In a typical environment, a client 205 executes a browser 301, TCP/IP stack 303, and a resolver 305. For reasons of performance and packaging, browser 301, TCP/IP stack 303 and resolver 305 are often grouped together as routines within a single software product.

Browser 301 functions as a graphical user interface to implement user input/output (I/O) through monitor 311 and associated keyboard, mouse, or other user input device (not shown). Browser 301 is usually used as an interface for web-based applications, but may also be used as an interface for other applications such as email and network news, as well as special-purpose applications such as database access, telephony, and the like. Alternatively, a special-purpose user interface may be substituted for the more general-purpose browser 301 to handle a particular application.

TCP/IP stack 303 communicates with browser 301 to convert data between formats suitable for browser 301 and IP format suitable for Internet traffic. TCP/IP stack also implements a TCP protocol that manages transmission of packets between client 205 and an Internet service provider (ISP) or equivalent access point. IP requires that each data packet include, among other things, an IP address identifying a destination node. In current implementations the IP address comprises a 32-bit value that identifies a particular Internet node. Non-IP networks have similar node addressing mechanisms. To provide a more user-friendly addressing system, the Internet implements a system of domain name servers that map alphanumeric domain names to specific IP addresses. This system enables a

name space that is more consistent reference between nodes on the Internet and avoids the need for users to know network identifiers, addresses, routes and similar information in order to make a connection.

The domain name service is implemented as a distributed database managed by domain name servers (DNSs) 307 such as DNS_A, DNS_B and DNS_C shown in FIG. 3. Each DNS relies on <domain name:IP> address mapping data stored in master files scattered through the hosts that use the domain system. These master files are updated by local system administrators. Master files typically comprise text files that are read by a local name server, and hence become available through the name servers 307 to users of the domain system.

The user programs (e.g., clients 205) access name servers through standard programs such as resolver 305. Resolver 305 includes an address of a DNS 307 that serves as a primary name server. When presented with a reference to a domain name (e.g., <http://www.circadence.com>), resolver 305 sends a request to the primary DNS (e.g., DNS_A in FIG. 3). The primary DNS 307 returns either the IP address mapped to that domain name, a reference to another DNS 307 which has the mapping information (e.g., DNS_B in FIG. 3), or a partial IP address together with a reference to another DNS that has more IP address information. Any number of DNS-to-DNS references may be required to completely determine the IP address mapping.

In this manner, the resolver 305 becomes aware of the IP address mapping which is supplied to TCP/IP component 303. Client 205 may cache the IP address mapping for future use. TCP/IP component 303 uses the mapping to supply the correct IP address in packets directed to a particular domain name so that reference to the DNS system need only occur once.

In accordance with the present invention, at least one DNS server 307 is owned and controlled by system components of the present invention. When a user accesses a network resource (e.g., a web site), browser 301 contacts the public DNS system to resolve the requested domain name into its related IP address in a conventional manner. In a first embodiment, the

public DNS performs a conventional DNS resolution directing the browser to an originating server 210 and server 210 performs a redirection of the browser to the system owned DNS server (i.e., DNS_C in FIG. 3). In a second embodiment, domain:address mappings within the DNS system are modified such that resolution of the of the originating server's domain automatically return the address of the system-owned DNS server (DNS_C). Once a browser is redirected to the system-owned DNS server, it begins a process of further redirecting the browser 301 to the best available front-end 201.

Unlike a conventional DNS server, however, the system-owned DNS_C in FIG. 3 receives domain:address mapping information from a redirector component 309. Redirector 309 is in communication with front-end manager 207 and back-end manager 209 to obtain information on current front-end and back-end assignments to a particular server 210. A conventional DNS is intended to be updated infrequently by reference to its associated master file. In contrast, the master file associated with DNS_C is dynamically updated by redirector 309 to reflect current assignment of front-end 201 and back-end 203. In operation, a reference to web server 210 (e.g., <http://www.circadence.com>) may result in an IP address returned from DNS_C that points to any selected front-end 201 that is currently assigned to web site 210. Likewise, web site 210 can identify a currently assigned back-end 203 by direct or indirect reference to DNS_C.

Front-end 201 typically receives information directly from front-end manager 207 about the address of currently assigned back-ends 203. Similarly, back-end 203 is aware of the address of a front-end 201 associated with each data packet. Hence, reference to the domain system is not required to map a front-end 201 to its appropriate back-end 203.

FIG. 4 illustrates principle functional components of an exemplary front-end 201 in greater detail. Primary functions of the front-end 201 include providing services on its own behalf and/or on behalf of a network server, and translating transport control protocol (TCP) packets from client 205 into TMP

packets used in the system in accordance with the present invention. It is contemplated that the various functions described in reference to the specific examples may be implemented using a variety of data structures and programs operating at any location in a distributed network. For example, a front-end 201 may be operated on a network appliance 107 or server within a particular network 102, 103, or 104 shown in FIG. 1. The present invention is readily adapted to any application where multiple clients are coupling to a centralized resource. Moreover, other transport protocols may be used, including proprietary transport protocols.

TCP component 401 includes devices for implementing physical connection layer and Internet protocol (IP) layer functionality. Current IP standards are described in IETF documents RFC0791, RFC0950, RFC0919, RFC0922, RFC792, RFC1112 that are incorporated by reference herein. For ease of description and understanding, these mechanisms are not described in great detail herein. Where protocols other than TCP/IP are used to couple to a client 205, TCP component 401 is replaced or augmented with an appropriate network protocol process.

TCP component 401 communicates TCP packets with one or more clients 205. Received packets are coupled to parser 402 where the Internet protocol (or equivalent) information is extracted. TCP is described in IETF RFC0793 which is incorporated herein by reference. Each TCP packet includes header information that indicates addressing and control variables, and a payload portion that holds the user-level data being transported by the TCP packet. The user-level data in the payload portion typically comprises a user-level network protocol datagram.

Parser 402 analyzes the payload portion of the TCP packet. In the examples herein, HTTP is employed as the user-level protocol because of its widespread use and the advantage that currently available browser software is able to readily use the HTTP protocol. In this case, parser 402 comprises an HTTP parser. More generally, parser 402 can be implemented as any parser-type logic implemented in hardware or software for interpreting the

contents of the payload portion. Parser 402 may implement file transfer protocol (FTP), mail protocols such as simple mail transport protocol (SMTP) and the like. Any user-level protocol, including proprietary protocols, may be implemented within the present invention using appropriate modification of
5 parser 402.

To improve performance, front-end 201 optionally includes a caching mechanism 403. Cache 403 may be implemented as a passive cache that stores frequently and/or recently accessed web pages or as an active cache that stores network resources that are anticipated to be accessed. In non-
10 web applications, cache 403 may be used to store any form of data representing database contents, files, program code, and other information. Upon receipt of a TCP packet, HTTP parser 402 determines if the packet is making a request for data within cache 403. If the request can be satisfied from cache 403 the data is supplied directly without reference to web server
15 210 (i.e., a cache hit). Cache 403 implements any of a range of management functions for maintaining fresh content. For example, cache 403 may invalidate portions of the cached content after an expiration period specified with the cached data or by web sever 210. Also, cache 403 may proactively update the cache contents even before a request is received for particularly
20 important or frequently used data from web server 210. Cache 403 evicts information using any desired algorithm such as least recently used, least frequently used, first in/first out, or random eviction. When the requested data is not within cache 403, a request is processed to web server 210, and the returned data may be stored in cache 403.

25 Several types of packets will cause parser 404 to forward a request towards web server 210. For example, a request for data that is not within cache 403 (or if optional cache 403 is not implemented) will require a reference to web server 210. Some packets will comprise data that must be supplied to web server 210 (e.g., customer credit information, form data and
30 the like). In these instances, HTTP parser 402 couples to data blender 404.

Optionally, front-end 201 implements security processes, compression processes, encryption processes and the like to condition the received data for improved transport performance and/or provide additional functionality. These processes may be implemented within any of the functional components (e.g., data blender 404) or implemented as separate functional components within front-end 201. Also, front-end 201 may implement a prioritization process to identify the priority of data packets. A prioritization program requires that front-end 201 include a data structure associating particular clients 205 or particular TCP packet types or contents with a prioritization information. Computation and management of the priority information, discussed hereinbelow in greater detail, is a significant feature of the present invention.

Blender 404 slices and/or coalesces the data portions of the received packets into prioritized "TMP units" that are sized for transport through the TMP mechanism 202. The data portion of TCP packets may range in size depending on client 205 and any intervening links coupling client 205 to TCP component 401. Moreover, where compression is applied, the compressed data will vary in size depending on the compressibility of the data. Data blender 404 receives information from front-end manager 207 that enables selection of a preferable TMP packet size. Alternatively, a fixed TMP packet size can be set that yields desirable performance across TMP mechanism 202. Data blender 404 also marks the TMP units so that they can be re-assembled at the receiving end.

Data blender 404 also serves as a buffer for storing packets from all clients 205 that are associated with front-end 201. Blender 404 mixes data packets coming into front-end 201 into a cohesive stream of TMP packets sent to back-end 203 over TMP link 202. In creating a TMP packet, blender 404 is able to pick and choose amongst the available packets according to priority information associated with the packets so as to prioritize some packets over others.

In an exemplary implementation, illustrated in Fig. 7, a "TMP connection" comprises a plurality of "TCP connection buffers", logically arranged in multiple "rings". A "socket" is a process that enables connection to and communication with a network protocol, such as an interface. TMP sockets comprise component connections each associated with a buffer that together form a TMP connection. Each TCP socket 701 maintained between the front-end 201 and a client 205 corresponds to a TCP connection buffer 702. When a TCP connection buffer 702 is created, it is assigned a priority. For purposes of the present invention, any algorithm or criteria may be used to assign a priority. Each priority ring is associated with a number of TCP connection buffers having similar priority. In a specific example, five priority levels are defined corresponding to five priority rings. Each priority ring is characterized by the number of connection buffers it holds (nSockets), the number of connection buffers it holds that have data waiting to be sent (nReady) and the total number of bytes of data in all the connection buffers that it holds (nBytes).

Referring to Fig. 6 and Fig. 7, when data arrives from a TCP socket, it is placed in a TCP connection buffer. The priority is then determined for the TCP connection buffer, if one has not yet been determined, or a default priority may be assigned. A TCP connection buffer 702 is sized to hold a plurality of TCP packets and each TCP connection buffer 702 is associated with a priority value. The priority value is assigned when TCP connection buffer 702 is first created and may be dynamically changed in operation. When composing TMP data packets, the blender 703 goes into a loop comprising steps illustrated in Fig. 6. These steps include:

Step 602: Find the number of bytes it can sent from each ring (nBytes), and the number of connections that are ready to send (nReady). An exemplary set of information gathered in step 601 is shown in Table 1 below:

PRIORITY	NBYTES	NREADY
0	1500	3
1	2000	3
2	500	1
3	1500	2
4	1000	1

Table 1

Step 603: Find how many bytes should be sent from each ring. This is based on a weight parameter for each priority. The weight can be thought of as the number of bytes that should be sent at each priority this time through the loop. In a particular example, the number of bytes (nSend) is calculated from: $nSend = nReady * weight$. An exemplary set of information gathered in step 602 is shown in Table 2 below:

PRIORITY	NBYTES	NREADY	WEIGHT	NSEND
0	1500	3	100	$100 * 3 = 300$
1	2000	3	200	$200 * 3 = 600$
2	500	1	300	$300 * 1 = 300$
3	1500	2	400	$400 * 2 = 800$
4	1000	1	500	$500 * 1 = 500$

Table 2

Step 604: Normalize nSend so that for the ring with the most data waiting $nBytes = nSendNorm$. In a particular implementation, a normalization factor "S" is computed from $S = nBytes / (Weight * nReady)$ for the ring with the greatest nReady (e.g., ring 0 or ring 1 in the particular examples). For each ring, a normalized nSend is computed by computing $S * nSend$. An exemplary set of information generated in step 603 is shown in Table 3 below:

PRIORITY	NBYTES	NREADY	WEIGHT	NSEND	NSENDNORM
0	1500	3	100	300	$300 * 3.33 = 1000$
1	2000	3	200	600	$600 * 3.33 = 2000$
2	500	1	300	300	$300 * 3.33 = 1000$
3	1500	2	400	800	$800 * 3.33 = 2666$
4	1000	1	500	500	$500 * 3.33 = 1666$

Table 3

Step 605: Send sub-packets from the different rings. This is done by taking a sub-packet from the highest priority ring and adding it to a TMP

packet 705 forming in TMP output buffer 704, then adding a sub-packet from each of the top two queues, then the top three, and so on. The first selection is a single sub-packet taken from the highest priority ring. The second selection comprises two sub-packets, one from the highest priority ring, and one from the next-highest priority ring. Third selection comprises one packet from ring 4, one packet from ring 3, and one packet from ring 2. When a ring is empty then the empty ring is skipped. This process is illustrated in Table 4 below:

PRIORITY	NBYTES	NREADY	WEIGHT	NSENDNORM	Sub-Packets
0	1500	3	100	1000	15
1	2000	3	200	2000	10, 14
2	500	1	300	1000	6, 9, 13
3	1500	2	400	2666	3, 5, 8, 12
4	1000	1	500	1666	1, 2, 4, 7, 11

Table 4

The particular processes described in reference Fig. 6 are provided as examples only, and may vary significantly to meet the needs of particular applications. For example, step 605 is readily implemented by selecting sub-packets from the priority rings in any order that ensures an adequate degree of fairness, while preferentially adding sub-packets from higher priority rings.

To illustrate this process it is assumed that sub-packets comprise 500 byte blocks (although sub-packet size can be selected to meet the needs of a particular application. The nBytes and nSendNorm values will change over time as sub-packets are selected.

For ease of discussion, the values of nSendNorm are rounded to the nearest 500 in the following discussion. At the start, the values are:

PRIORITY	NBYTES	NSENDNORM	Sub-Packets
0	1500	1000	
1	2000	2000	
2	500	1000	
3	1500	2500	
4	1000	1500	

Table 5

After the first sub-packet is written out, the nBytes and nSendNorm values of the priority 4 ring are decremented by 500 to yield:

PRIORITY	NBYTES	NSENDNORM	Sub-Packets
0	1500	1000	
1	2000	2000	
2	500	1000	
3	1500	2500	
4	500	1000	1

Table 6

The next 2 sub-packets are written out from rings 4 and 3. In practice, an actual TMP packet may well be full at this point and is sent now. However, the selection process continues.

PRIORITY	NBYTES	NSENDNORM	Sub-Packets
0	1500	1000	
1	2000	2000	
2	500	1000	
3	1000	2000	3
4	0	500	1, 2

Table 7

The next sub-packet (e.g., sub-packet 4) is considered, there is no data available (nBytes=0 in ring 4), but nSendNorm is decremented anyway. Subpacket 4 would have been then included if nBytes >0, but because nBytes=0 sub-packet 4 is skipped.

PRIORITY	NBYTES	NSENDNORM	Sub-Packets
0	1500	1000	
1	2000	2000	
2	500	1000	
3	1000	2000	3
4	0	0	1, 2, 4

Table 8

After 11 more sub-packets are written out (or considered) where the sub-packet numbers indicated in bold text represent sub-packets that were sent, while the non-bold text indicates sub-packets that were considered but not sent because the associated TCP connection buffer 702 was empty:

PRIORITY	NBYTE S	NSENDNORM	Sub-Packets
0	1000	500	15
1	1000	1000	10, 14
2	0	0	6, 9, 13
3	0	500	3, 5, 8, 12
4	0	0	1, 2, 4, 7, 11

Table 9

Three events will function to stop this loop:

A) When all of the nBytes=0; or

B) When all of the nSendNorm=0, or

5 C) When the TMP packet cannot be sent because the underlying TMP protocol has limited the data flow.

While there is still more data to send, the loop will continue.

10 Consideration of the next 15 sub-packets will result in selection of two sub-packets from ring 1 and one subpacket from ring 0, after which all of the data that will be sent this round has been sent. At this point, more data is read in from the TCP connection buffers 702, nBytes is reset, nSendNorm is recalculated and the loop begins again.

15 When a sub-packet cannot be written because all of TMP output buffers 704 are full, the sending loop is exited and packets can be added to TCP connection buffers 702 as new TCP packets are received. When this happens, nBytes can change before the sending loop is restarted.

20 Step 606, which is implemented as a part of Step 605 in a particular embodiment: Within each ring, sub-packets are added round robin. Keeping in mind that each priority ring may comprise multiple TCP sockets (nSockets≥0) and so multiple TCP connection buffers, when a sub-packet is added from a TCP connection buffer the ring is "rotated" at 605 so the next sub-packet the ring adds will come from a different TCP socket buffer. Each sub-packet can be up to 512 bytes in a particular implementation. If the TCP connection buffer has less than 512 bytes waiting, the data available is added
25 to the TMP packet 904.

Step 606: When a full (roughly 1.5 kB) TMP packet 704 is built, it is sent. A full TMP packet 704 may comprise three or more sub-packets, depending on the sub-packet size. The TMP packet 704 will also be sent when there is no more data ready.

5 TMP mechanism 405 implements the TMP protocol in accordance with the present invention. TMP is a TCP-like protocol adapted to improve performance for multiple channels operating over a single connection. Front-end TMP mechanism 405 and corresponding back-end TMP mechanism 505 shown in FIG. 5 are computer processes that implement the end points of
10 TMP link 202. The TMP mechanism in accordance with the present invention creates and maintains a stable connection between two processes for high-speed, reliable, adaptable communication.

 TMP is not merely a substitute for the standard TCP environment. TMP is designed to perform particularly well in environments such as the
15 Internet. TMP connections are made less often than TCP connections. Once a TMP connection is made, it remains up unless there is some kind of direct intervention by an administrator or there is some form of connection breaking network error. This reduces overhead associated with setting up, maintaining and tearing down connections normally associated with TCP.

20 Another feature of TMP is its ability to channel numerous TCP connections through a single TMP pipe 202. The environment in which TMP resides allows multiple TCP connections to occur at one end of the system. These TCP connections are then mapped into a single TMP connection. The TMP connection is then broken down at the other end of the TMP pipe 202 in
25 order to traffic the TCP connections to their appropriate destinations. TMP includes mechanisms to ensure that each TMP connection gets enough of the available bandwidth to accommodate the multiple TCP connections that it is carrying.

 Another advantage of TMP as compared to traditional protocols is the
30 amount of information about the quality of the connection that a TMP connection conveys from one end to the other of a TMP pipe 202. As often

happens in a network environment, each end has a great deal of information about the characteristics of the connection in one direction, but not the other. By knowing about the connection as a whole, TMP can better take advantage of the available bandwidth.

5 In contrast with conventional TCP mechanisms, the behavior implemented by TMP mechanism 405 is constantly changing. Because TMP obtains bandwidth to host a variable number of TCP connections and because TMP is responsive information about the variable status of the network, the behavior of TMP is preferably continuously variable. One of the
10 primary functions of TMP is being able to act as a conduit for multiple TCP connections. As such, a single TMP connection cannot behave in the same manner as a single TCP connection. For example, imagine that a TMP connection is carrying 100 TCP connections. At this time, it loses one packet (from any one of the TCP connections) and quickly cuts its window size in half
15 (as specified for TCP). This is a performance reduction on 100 connections instead of just on the one that lost the packet.

 Each TCP connection that is passed through the TMP connection must get a fair share of the bandwidth, and should not be easily squeezed out. To allow this to happen, every TMP becomes more aggressive in claiming
20 bandwidth as it accelerates. TMP also ensures that it becomes more and more resistant to backing off with each new TCP connection that it hosts. A TMP connection that is hosting more than one TCP connection should not go down to a window size of one.

 In a particular implementation, every time a TCP connection is added
25 to (or removed from) what is being passed through the TMP connection, the TMP connection behavior is altered. It is this adaptation that ensures successful connections using TMP. Through the use of the adaptive algorithms discussed above, TMP is able to adapt the amount of bandwidth that it uses. When a new TCP connection is added to the TMP connection,
30 the TMP connection becomes more aggressive. When a TCP connection is

removed from the TMP connection, the TMP connection becomes less aggressive.

5 TMP pipe 202 provides improved performance in its environment as compared to conventional TCP channels, but it is recognized that TMP pipe 202 resides on the open, shared Internet backbone in the preferred implementations. Hence, TMP must live together with many protocols and share the pipe efficiently in order to allow the other transport mechanisms fair access to the shared communication bandwidth. Since TMP takes only the amount of bandwidth that is appropriate for the number of TCP connections that it is hosting (and since it monitors the connection and controls the number of packets that it puts on the line), TMP will exist cooperatively with TCP traffic. Furthermore, since TMP does a better job at connection monitoring than TCP, TMP ends up surpassing TCP in regards to this requirement.

15 Also shown in FIG. 4 are data filter component 406 and HTTP reassemble component 407 that process incoming (with respect to client 205) data. TMP mechanism 405 receives TMP packets from TMP pipe 202 and extracts the TMP data units. Using the appended sequencing information, the extracted data units are reassembled into HTTP data packet information by HTTP reassembler 407. Data filter component 406 may also implement data decompression where appropriate, decryption, and handle caching when the returning data is of a cacheable type.

25 FIG. 5 illustrates principle functional components of an exemplary back-end 203 in greater detail. Primary functions of the back-end 203 include translating TCP packets from web server 210 into TMP packets as well as translating TMP packets into the one or more corresponding TCP packets generated by clients 205. TMP unit 505 receives TMP packets from TMP pipe 202 and passes them to HTTP reassemble unit 507 where they are reassembled into the corresponding TCP packets. Data filter 506 may
30 implement other functionality such as decompression, decryption, and the like

to meet the needs of a particular application. The reassembled data is forwarded to TCP component 501 for communication with web server 210.

TCP data generated by the web server process are transmitted to TCP component 501 and forwarded to HTTP parse mechanism 502. Parser 502
5 operates in a manner analogous to parser 402 shown in FIG. 4 to extract the data portion from the received TCP packets, perform optional compression, encryption and the like, and forward those packets to data blender 504. Data blender 504 operates in a manner akin to data blender 404 shown in FIG. 3 to buffer and prioritize packets in a manner that is efficient for TMP transfer.

10 Priority information is received by, for example, back-end manager 209 based upon criteria established by the web site owner. TMP data is streamed into TMP unit 505 for communication on TMP pipe 202. Priority information used by back-end 203 need not be but may be identical to the priority information used by an associated front-end 201.

15 Fig. 8 is a high-level flow chart representation describing actions undertaken in a packet prioritization function in accordance with the present invention. As noted hereinbefore, the actions illustrated in Fig. 8 may take place at any intermediary computing device between a client 205 and a server 210, however, for ease of description the prioritization process will be
20 described in terms of processes undertaken at a front-end 201. The prioritization function is initialized at 801 and front-end receives one or more unprioritized client data packets at 802. At step 803, priority information is obtained and an effective priority value is determined from the priority information. Queue order is then determined at step 804. Packets are
25 transmitted at step 805. At step 806, the system determines whether there are packets remaining in buffer. If packets remain in the buffer, the system determines whether additional incoming packets are received at step 807. If additional packets are received, the system proceeds to step 803. If additional packets are not received, the system proceeds to step 804. If there
30 are no packets remaining in the buffer at step 806, the system proceeds to step 808 and the function is terminated.

In one embodiment, the function starts at 801 each time a connection is established between clients 205 and web server 210, wherein at least one network computer 201, 203 serves as an intermediary web server. Client 205, web server 210, and the at least one network computer 201 and/or 203
5 comprise a network for purposes of this disclosure. At step 802, an intermediary web server receives at least one set of information. A set of information may comprise a packet, a connection between a client and a server, a combination thereof, or other information that is transmitted between two network devices. Each set of information may contain priority
10 information. Priority information comprises priority values, priority parameters, as well as information for translating a priority parameter to a priority value. Priority information may also include weighting algorithms used to combine multiple priority values into an effective priority value that determines transmission order across TMP link 202.

In one embodiment, priority parameter and priority values are received
15 at step 802. For example, an intermediary may receive a packet that includes one or more priority parameters and/or one or more priority values. A priority parameter is an attribute associated with a set of information, such as an attribute associated with a network device that requested the set of
20 information, an attribute associated with a network device that transmitted the set of information, or other attributes. Priority parameters are communicated between network devices as part of a data packet using type:value pairs, for example. Alternatively, priority parameters may be communicated based on a predetermined type:value scheme, such as transmitting a first priority
25 parameter in a specified location of a packet and a second priority parameter in a second location of the packet.

The type:value scheme may be updated by an administrator from time-to-time and/or dynamically generated based on network conditions. Additionally, priority parameters may be determined based on the set of
30 information that is being transmitted across the network. For example, a URL for a requested web page may be parsed to identify and a portion of the URL

used as a priority parameter for the request. A request may be associated with one or multiple priority parameters.

A priority value is a numeric or arithmetic value that establishes a priority for a set of information based on a priority parameter. A priority value distinguishes between different priorities based on a prioritization scheme, such as a priority scheme allowing integer values from 1-10 or for a Boolean type prioritization scheme allowing values of 0 or 1. A priority parameter is associated with a priority value based on mapping information. Priority valuation information may be stored in one or more data stores and serves to associate each priority parameter to a priority value. For example, if a priority parameter for a web site priority parameter type is www.vr1.com (e.g., webSiteID=www.vr1.com), this priority parameter is mapped to a priority value, such as "high" or 10. The mapping from a priority parameter to a priority value is implemented at step 603 in Fig. 6.

The parameter valuation information may be statically defined, but is preferably dynamically alterable by the front-end manager 207, back-end manager 209, and/or the owner/operator of a web site 210. The entities that are permitted to modify the priority valuation information as well as any rules controlling such modification are to be determined on a case-by-case basis to meet the needs of a particular application. For example, the valuation given to parameters associated with content priority should be alterable by the site owner associated with the content as would site-specified user priority parameters. In contrast, the priority value associated with a global priority parameter that is relevant across multiple domains may be controlled only by logic within front-end 201 and/or front-end manager 207, for example.

Priority information is preferably transmitted with the set of information in the form of one or more parameters appended to the set of information. This is akin to the manner in which cookies are transmitted with an HTTP request packet as a parameter appended to the URL. Alternatively or in addition, some types of priority information may be transmitted on a separate out-of-band management system channel, or by a combination thereof. In

one embodiment, priority values and priority parameters are transmitted with the set of information while priority valuation information and weighting algorithms are transmitted via the out-of-band management system channel.

Priority information may be stored on an intermediary computer such as front-end 201 and back-end 203, on web server 210, on clients 205, on other network devices, or a combination thereof. For example, clients 205 may contain cookies provided by an intermediary and/or web server 210 that identify one or more priority parameters associated with each of the clients 205. Additionally, once a priority parameter is mapped to a priority value, the relationship between the priority parameter and the priority value may be maintained by the intermediary computer for a predetermined amount of time and/or until a predetermined event. For example, once a priority value associated with a user identification priority parameter of "Ted Smith" is determined to be "1" by an intermediary computer, the intermediary computer may store this information until a connection with a client identified as "Ted Smith" is closed.

One embodiment of the present invention selectively prioritizes sets of information based on the priority parameters associated with each of the following priority parameter types: user identification, session identification, content identification, specific content elements, parsed data in the stream, rules specified by the content provider, rules specified by a user, soft landing, requested information volatility, and type of connection established. A client, a content provider or other entity may specify the priority parameter information and the priority valuation information used for the specified priority parameters.

User identification priority information provides information that is used to determine a user-specific priority value. For example, a user identification associated with a set of information, such as a packet or a connection, may provide a priority value directly. For example, a user identification value may identify a user as a high or low priority user or a priority based on another priority range such as one to ten. Alternatively, the set of information may

include information that is used by the system to determine a user identification priority value. For example, the set of information may identify a user associated with the set of information, such as by user name, user account number, IP address or other information. This user identification value must be mapped by the system to a priority value. In this way, a set of information having a user identification value of "Fred Smith" may be translated into a user identification priority value, such as "high" or "10."

A user may gain high or higher priority status by paying for preferential treatment, such as by paying an extra fee to an Internet Service Provider. Additionally, the user may acquire preferential treatment by conducting multiple purchases or other transactions online. Other criteria for conferring prioritized treatment based on user identification may also be used. Similarly, high priority status may be conferred to a user based on a number of a certain type of connection a user creates, such as the number of secure connections created by the user.

Session identification priority information identifies a session that warrants preferential treatment. For example, if a session has completed two online transactions, the system may want to encourage further transactions by providing high priority to packets associated with the session. In this way, bandwidth may be effectively shifted from sessions that are not generating revenue to sessions that are generating revenue.

Content identification priority information relates to the type of data that is being transmitted. A content parameter may comprise a file location or branch within a directory structure as indicated in a URL. Alternatively, a content parameter may comprise data within a packet itself such as a packet containing an advertisement or company logo that the site owner wishes to be transmitted with a high degree of reliability. For example, if a packet relates to the completion of an online sale, a content identification priority parameter may be set to indicate high priority (e.g., 10) or may be set to indicate "sale."

Specific content element priority information may be used to identify particular types of content that warrant high priority. For example, if a

merchant wants to have banner ads appear on a web page first, packets containing banner ads may have a high priority. Of course, banner ads could be explicitly given a lower priority as well. Additionally, if a user wants to receive video content only after all non-video content is received, video files
5 may receive a low priority. Some form of arbitration may be implemented by the system to determine which packets receive highest priority when a user and a content provider have different prioritization schemes. For example, if a user wants banner ads to appear last and audio files to appear first, the system may determine which entity, user or content provider, is more valuable
10 to the system or use other criteria in determining how to prioritize packets transmitted to the client.

Parsed data element priority information includes any data element in the packet body that has been assigned a priority determining nature. For example, if the packet is an XML document, parser 402 may parse the
15 content of the packet to determine a document type definition (DTD) and read one or more tags in the packet. The DTD may establish the type of content that is to be given highest priority. For example, with a music-related DTD, audio content may be given a high priority, whereas with an e-commerce related DTD, audio files may be given a low priority. The content provider
20 may override the default DTD-based prioritization values.

Parsed URL priority information comprises priority information associated with a URL itself. For example, a request for a document from a /sale directory may be given a higher category than a request for a document from an /AboutUs directory. HTTP packets as identified in the protocol field
25 of the URL may given higher/lower priority than FTP packets. The web site administrator may change the priority scheme associated with various web site directories or web site documents from time to time. Modifications to a priority scheme may be communicated to one or more back-end server computers or other network device by an out-of-band management system.

30 Soft landing priority information identifies the likelihood or possibility that a soft landing will satisfy a request for information from a web site. The

term "soft landing" as used herein refers to substitute services provided in substitution for requested services when the requested services cannot be timely provided. For example, there is a relatively high likelihood that a user who makes a request for a home page of a physical store's web site will be satisfied to receive a soft landing that provides a predetermined set of information, such as location, hours of operation, a phone number, and perhaps a coupon redeemable for discounted services when the requested service becomes available. On the other hand, there is a relatively low likelihood that a user who makes a request for flight information will be satisfied to receive a soft landing that provides alternative information.

Volatility priority information identifies the time-sensitivity associated with requested information. Highly volatile information may have a higher priority value than non-volatile information. For example, a user requesting stock information is likely to be dissatisfied if the requested information does not arrive quickly because the volatility of stock market information is extreme. On the other hand, a user requesting information from a real estate web site may not notice a small delay in obtaining requested information, because there is a lower degree of volatility associated with real estate information. Accordingly, a requested information volatility priority parameter for a stock information request will be greater than a requested information volatility priority parameter for a real estate information request.

User-specified preference priority information identifies a user-specific priority scheme. For example, a first user may want to experience the multimedia aspect of web pages, and establish a priority scheme that attempts to bring all multimedia content associated with a web page to the user as quickly as possible. A second user may want to access text information as quickly as possible, and establish a priority scheme that increases the priority associated with text and decreases the priority associated with all other types of media. Other priority parameter types may be used in accordance with user settings, website administrator settings, network administrator settings, or other settings.

While the above description identifies particular kinds and uses of priority information, the exemplary web-based implementation uses four types of parameter information: content priority information, client-assigned user priority information, client-specific user priority information, and global user priority information.

The content priority information is the priority value placed on the web site content as determined by a web site administrator. Content priority has named values from 0 to 4:

Low (0)

Basic (1)

Facilitated (2)

Expedited (3)

Urgent (4)

Secure transactions default to the content priority level set in by the administrator. In practice, a map of the site is transmitted to the back-end 203 supporting a particular web site and a content priority value is associated with each page of content. If a page does not have a content priority explicitly assigned, the priority of the page in the HTTP referred-by field can be used.

Client-assigned user priority information (CAP) is a means by which the web site 210 can insert tags into the generation of dynamic pages, to allow user requests to be given a priority based on some information that web site 210 has about the user making a request. In a particular example, CAP will have values 0-4. The CAP is communicated to a back-end 203 by a parameter encoded in the HTML header. This parameter is encoded as: `<!CrcdncPri=x>` where "x" can be a number form 0-4.

A client-specific user priority (CSUP) aggregates priority information over a plurality of web sites 210. In contrast to the CAP, the CSUP is derived from the content priorities of a plurality of web pages. More generally, the CSUP information is used to aggregate priority of a variety of like-kind or

dissimilar services that are requested by a particular user. In a particular embodiment, the content priority value for each web page that is requested is converted to a "page credit". This process allows higher priority pages to have a stronger influence on the effective priority computed later. As an example, the conversion to page credits can be performed with a simple look-up table shown in Table 10:

Content Priority	Credits per page viewed
0	0
1	1
2	2
3	5
4	20

Table 10

Each time a page with a content priority of 4 is viewed, a credit of 20 is added to the domain user priority value. The credit per page viewed may be altered to affect the desired influence on the effective priority value. In this manner, the client-specific user priority information can be used to identify a user that views many high-priority pages on a number of web sites 210 (e.g., a frequent purchaser) even if the particular user has never visited a particular site 210.

In accordance with the present invention, the priority values are exchanged between entities in the form of parameters. Each entity (i.e., clients 205, front-end 201, back-end 203, managers 207 and 209, and server 210) are uniquely situated to gather data, perform calculations, and store the various priority information. Particularly in web-based applications, there is no readily available mechanism for exchanging this state information between entities. In accordance with the present invention, the priority information is exchanged as parameters appended to the message body portion of HTTP packets. More generally, priority information can be appended to any packet or URL scheme that supports passing arbitrary parameters within the payload portion.

HTTP packets may carry other parameters that are unrelated to the prioritization system of the present invention. The preferred implementations use rules to help distinguish parameters that pass prioritization information from other parameters:

5 The priority parameters are always put at the end of the packet.

The beginning of the priority parameters is indicated by a "?". This means that either all of the data after the last "?" are priority parameter.

Each priority parameter will begin with a delimiter character (e.g., "*"). This makes parsing easier, since the parameters are always in the format
10 "?*aaa*bbb".

Priority parameters are of a specific form and length, and always have at least one checksum.

As long as no other parameters begin with a "?" and have a similar length and form, it is possible to distinguish prioritization parameters from
15 non-prioritization parameters.

Returning to Fig. 8, at step 803, the system determines priority information for incoming packets. In the particular examples, the client-specific user priority (CSUP) information is stored in a cookie on client 205 which will be transferred in the HTTP request packet. When a web page is
20 sent to client 205, the CSUP cookie is updated with a new priority value indicating the accumulated page credits. In one embodiment, an intermediary (e.g., front-end 201 and/or back-end 203) determines priority information for a received set of information, such as a packet. As between a client 205 and a
25 front-end 201, for example, conventional cookie exchange mechanisms can be used to exchange priority information because the client 205 believes that the assigned front-end 201 is in the domain of the origin server to which the request is ultimately directed.

The priority value is determined from a priority parameter using priority valuation information. For example, an intermediary computer, such as back-
30 end 203, may receive a priority parameter that identifies a type of content that

is contained in a packet, such as a banner advertisement. The intermediary may contain mapping information that allows the intermediary to determine a priority value associated with the priority parameter. For example, the intermediary may contain a table that maps each priority parameter to a priority value. In this way, the intermediary may determine a content type priority value associated banner advertisement content. Alternatively, the intermediary may request priority valuation information from another intermediary or another network device. In a preferred embodiment, the packet may be assigned a default priority value until a rationally based priority value is determined by the system.

Once a priority parameter is mapped to a priority value, the priority value may be maintained at one or more computers associated with a network connection. For example, the priority value associated with a user identification may be stored as part of a cookie on the client and/or stored for the duration session in a data store of an intermediary. Additionally, priority values may be appended to a set of information, such as by appending a value to a packet header in a predetermined location or placing a type:value pair in a packet body.

Two or more priority values may be used to determine at least one effective priority value. The intermediary may implement a weighting function between two or more priority values based upon one or more weighting algorithms. For example, a request packet is associated with a client-assigned priority (CAP), a client-specific user priority (CSUP), and a content priority (CP). The three priority values are combined using a weighting algorithm:

$$A*CSUP + B*CAP + C*CP$$

$$ETP = \frac{\quad}{\quad}$$

$$A + B + C$$

where

EP = Effective Transaction Priority;

CSUP = Client-Specific User Priority;

CAP = Client-Assigned Priority; and

CP = Content Priority.

5 A, B, and C are weights that determine the influence of each of the three priority values respectively on the final Effective Transaction Priority. These constant values are dynamically configurable.

10 Other weighting algorithms, including linear and non-linear algorithms, may be used. Weighting algorithms may be communicated between network devices via the out-of-band management system, as part or all of a data packet, or by other available techniques. In this manner, an effective priority value may be determined based on the priority values associated with a user identification and a requested web site. Each of the components of the aggregate value may be given the same or different weights. For example, the priority value associated with the user identification may be twice as
15 important as the priority value associated with the requested web site in determining an aggregate priority value (e.g., $A=B=2$, $C=1$ in the formula above). The weights of each of the components of the aggregate priority value may be determined by a system administrator, a content provider, a user, a combination of the aforementioned, or by other criteria.

20 Sets of information are transmitted across and within the network in accordance with at least one priority value (e.g., the effective transaction priority) at step 804. For example, packets having a high priority may be transmitted before packets having a low priority. If a range of priority values is available, packets having the highest priority value may be transmitted each
25 transmission cycle. If all packets having a particular priority value cannot be transmitted during a particular transmission cycle, packets that have been within the network for the longest amount of time may be transmitted prior to packets having similar priority values that have not been in the network as long.

Any sets of information that cannot be transmitted during step 804 may be maintained at the appropriate network device and the function may be repeated. In one embodiment, the number of transmission cycles that a set of information remains in the network influences a time-based priority value associated with the set of information. For example, a packet initially having a low priority that remains in a buffer for a predetermined number of cycles may be transmitted from the buffer instead of another high priority packet that has just arrived in the buffer.

Fig. 9 illustrates entities and relationships established during a web-based interaction in accordance with the present invention. In the example of Fig. 9, the user of client 205 desires to connect to the URL "http://www.a.com/index.html?1234". In this example, "www.a.com" is the web server, "index.html" is the specific web page, and "1234" is an additional parameter that is being passed to the web server 210.

The user types a URL, or selects a link to a URL, in a web browser operating on client 205. The URL of the destination web server customer will be redirected, via the DNS redirector system described in reference to Fig. 3, to a front-end 201. Client 205 does a DNS lookup on "www.a.com". This lookup results in the identification of an appropriate front-end 201. The numerical IP address of the selected front-end 201 is returned to client 205. In response, client 205 will recognize the returned IP address as the location of the "www.a.com" domain and send the request (e.g., GET index.html?1234 HTTP/1.1) to the returned IP address. This GET request includes a host parameter "Host: www.a.com" provided by redirector 309 that identifies a particular destination web server 201. The front-end 201 will receive the HTTP request and extract the destination hostname from the HTTP 'Host:' parameter in the client request so it knows to which back-end 203 and ultimately which destination web server 210 the client 205 desires to reach.

Front-end 201 checks for the presence of cookies in the HTTP request, and in particular checks for the presence of a "domain cookie" that includes

the client-specific user priority information. When a domain cookie is present, the request includes:

GET index.html?1234 HTTP/1.1

Host:www.a.com

5 Cookies: Id: CrcdncCGW Data: CookieDataCRC

where the name of the domain cookie is "CrcdncCGW Data" and the value is "CookieDataCRC", although these designations are a simple matter of nomenclature. The cookie value contains the following information in a particular example:

Field	V.1 offset /size	Legal Values
Version Number	0 / 1	0 = debug version 1 = initial release
User Priority	1 / 1	0-4
Priority Update Interval	2 / 1	7-12
Hits This Interval	3 / 2	0-4096
Credits This Interval	5 / 3	any
Checksum	13 / 4	0
Salt	any	any

10

In actuality, a domain cookie might look like "1plhhCCCgl6fG" as the cookie information is transmitted in an encoded form. The version offset/size indicates the number of bits used to convey the specified field of information and does not need to be explicitly transmitted as it is implicitly conveyed in the "version number" information. The version number specifies the format of the cookie to allow for future updates by increasing or decreasing the size of particular fields, and providing for the addition or deletion of fields included in the cookie information. The user priority field conveys the DSUP value. The priority update field indicates the effective expiration of the CSUP cookie by indicating a number of hits before this domain's priority requires updating (e.g., by redirection to HTTP redirector 901). The hits this interval field indicates a number of hits recorded in this domain (i.e., www.a.com) during this interval where an interval refers to the time since the domain cookie was

15

20

last updated by redirection to HTTP redirector 901. Credits this interval indicates the number of page credits recorded in this domain during this interval.

5 Preferably a checksum or CRC field is also included to ensure the cookie data has not been corrupted or tampered with. Because the cookie data is encrypted, any change to the encrypted cookie will alter the checksum bits. When the checksum or CRC is not correct, front-end 201 will assume that the cookie has become corrupted and will get a new cookie from HTTP redirector 901 in a manner similar to when a CSUP cookie does not exist.

10 Front-end 201 preferably does not pass domain cookies to server 210. The CSUP cookie information is stored in front-end 201 to be used when a response is sent to client 205.

Front-end 201 reads parameters being passed in the request 902, including the Host: parameter described above. As described below, the GET

15 request includes additional parameters when there has been a redirection to/from an HTTP redirector 901. One parameter that is included in a particular example is called a "link code". A back-end 203 writes link codes into all of the web pages that it returns to a client 205 (via a front-end 201). Hence, whenever a user of client 205 follows a hypertext link that points to

20 another page or resource within a domain, the link code can be included in the request. In the particular examples, the link code includes a field to identify the server 210 associated with the link code. Also, the front-end 201 may insert a link code as a parameter in redirect message 915 which is then passed as a parameter to HTTP redirector 901 in message 906, and passed

25 back to client 205 in redirect message 916. Using link codes, it is not necessary to include an additional parameter to identify the host name of server 210 because that information is already included in the link code. Like CSUP cookies, the link code is preferably stripped from the request before it is passed to server 210.

30 After receiving the HTTP request, front-end 201 checks cache 403 to see if the requested content is available locally. When the content is not

available or is older than specified caching parameters, the request is passed to back-end 203 without the CSUP cookie or link code parameters in a blended packet 803. The blended packet 903 comprises multiple request packets from multiple clients 205. The actual composition of any particular
5 blended packet 903 is determined by the relative priority values associated with each particular request packet 902.

Back-end 203 receives blended packet 903, un-blends it, and forwards each request within the blended packet 903 as an unblended request packet 904 to the corresponding server 210. Any cookies that the site "www.a.com"
10 expects will be included in the HTTP request from back-end 203. From the perspective of each server 210, a conventional HTTP request packet is received and a response 914 is generated including the requested content and/or services. Response 914 may also include priority information (e.g., content priority and/or client-assigned priority) in the form of parameters.
15 Back-end 203 extracts the parameter information from response 914. Back-end 203 also examines each embedded link within response 914 and modifies each link as necessary to ensure that the link is relative to the web site root (if not already) so that redirector 309 does not need to be consulted when the links are followed by a client 205. The links are also modified as
20 necessary to include a link code indicating content priority of the content pointed to by the link.

Back-end 203 maintains a map of the web site and/or services provided by server 210 and content priority associated with each resource within the web site and/or service. Back-end 203 uses this information to
25 associate a content priority with each response 914. Optionally, any given response 914 may also include a parameter indicating a client-assigned priority CAP value. In a particular example, the SSUP is encoded as a command in the HTML header of an HTML document being transmitted by response 914 in the form: <!CrcdncPri=x> where "x" is a number between 0
30 and 4. The CAP provides a means by which the server 210 can, but is not required to, insert tags, recognizable by back-end 203 into response 814.

Back-end 203 computes an effective priority for each response 814 based upon the content priority, CAP, and/or the client-specific user priority included in the link code, if any, transmitted with the request 802. The algorithm and weighting applied by back-end 203 is independent of the
5 priority and weighting algorithm applied by front-end 201. As a result, the effective priority of a response packet 913 may be different from the effective priority applied to the corresponding request packet 802.

The modified responses 814 are blended according to a computed effective priority value and transmitted in a blended packet 913. Blended
10 packet 913 may comprise multiple response packets 914 in a proportion determined by a weighting algorithm implemented within back-end 203. Where front-end 201 transmits user-identification information to back-end 203, the weighting algorithm may account for CSUP and CAP in addition to content priority provided by server 210.

15 Optionally, a cache mechanism (not shown) may be included within back-end 203 to selectively cache content, preferably after link modification described above. When content is cached, back-end 203 may deliver content from the cache rather than generating a request to server 210.

Front-end 201 receives the blended packet 913 and generates an
20 unblended response packet 912 for each response 914 contained therein. Where content is indicated as cacheable, front-end 201 places a copy of the content in its cache as described hereinbefore. From the perspective of client 205, the response 914 appears to have come directly from server 210. Response 914 includes SET cookie information required to update the
25 domain cookie to reflect the new CSUP value, including page credits resulting from the current request.

When a domain cookie is not present, i.e. this client 205 has not visited this domain previously, then the client 205 is redirected to a common domain (e.g. "gateway.circadence.com"), which is running an HTTP redirector
30 application 901. Likewise, when the domain cookie has expired, redirection to HTTP redirector 901 is performed. The HTTP redirector application, in

practice, may be implemented on the same physical machine as front-end 201. Also, in the preferred implementations, each domain cookie has a defined expiration after which it must "check in" with the HTTP redirector application 901. The expiration may be measured in terms of time (e.g., every 7 days), usage (e.g., every 1000 times the domain cookie is received by a front-end 201) or other available criteria, including random expiration criteria.

To redirect a client 205 to HTTP redirector 801, client 205 is sent an HTTP Redirect response 915 (e.g., Redirect: gw.circadence.com/index.html?1234?*LinkCdCRC *00000000000*www.a.com HTTP/1.1). The original domain, "www.a.com" is sent as a parameter in the URL. This causes client 205 to perform a DNS lookup on "gateway.circadence.com" and then send HTTP redirector 901 an HTTP GET request. When HTTP Redirector is run as a separate process on front-end 201 the DNS lookup will give the same numerical IP address as returned for the original "www.a.com".

The domain cookie data from the original request to front-end 201 is also sent as a parameter. To indicate that no domain cookie is available, a zeroed cookie is sent. This allows the HTTP redirector the read and write a global cookie in global cookie database 307 as needed. HTTP redirector 801 will receive a request in the form:

```
GET index.html?1234?*LinkCdCRC*00000000000*www.a.com HTTP/1.1
```

```
Host: gateway.circadence.com
```

```
Cookies: Id: CrcdncCGW Data: GlobalCookCRC
```

HTTP redirector 901 reads the domain cookie parameter and computes a global priority value based upon the CSUP sent in the domain cookie parameter and a stored global user priority (if available). When no domain cookie is available as indicated by a zeroed cookie received in the GET request, HTTP redirector 901 will create a domain cookie based upon a default value.

HTTP redirector 901 sends an HTTP redirection command to client 205, sending client 205 back to front-end 201 and the original domain. When a new domain cookie is created, it is passed to client 205 in the redirect response 916 in the form:

5 Redirect: www.a.com?1234?*LinkCdCRC*CookieDataCRC HTTP/1.1.

The parameter returned contains domain cookie data for front-end 201. Front-end 201 stores this updated cookie and writes it to client 205 when it sends response message 912. Client 205 will store the domain cookie (e.g., Cookies: Id: CrcdncCGW Data: CookieDataCRC). The cookie,
10 and therefore the user data, will be available directly the next time client 205 connects to this client domain (e.g., www.a.com).

Although the invention has been described and illustrated with a certain degree of particularity, it is understood that the present disclosure has been made only by way of example, and that numerous changes in the
15 combination and arrangement of parts can be resorted to by those skilled in the art without departing from the spirit and scope of the invention, as hereinafter claimed.

We claim:

1. A method for transmitting packets from a computer onto a network, said method comprising the acts:
 - receiving at least two data sets;
 - 5 determining a priority value for each of the at least two data sets;
 - composing a composite data set comprising portions of the at least two data sets such that an amount of data from each of the data sets within the composite data set is based upon relative priorities between each of the at least two data sets; and
 - 10 transmitting the composite data set onto the network.
2. The method of claim 1 wherein the act of receiving comprises:
 - creating a group comprising a plurality of connection buffers for each data set; and
 - assigning a priority to each created group.
- 15 3. The method of claim 2 wherein the step of creating comprises:
 - monitoring the speed of the connection supplying data to each connection buffer; and
 - adjusting the size of the corresponding connection buffer to maintain a buffer sized to hold packets received over a preselected time interval.
- 20 4. The method of claim 3 wherein the preselected time interval is at least as long as the time required to complete the composing step.
5. The method of claim 1 further comprising:
 - determining a weight value for each data set; and
 - selecting portions of the first and second data sets in an order at least
 - 25 partially based upon the weight value.
6. The method of claim 1 wherein the step of composing comprises:
 - creating a connection buffer for each data set;

organizing the connection buffers into logical rings of like priority value;
 selecting portions of data from each logical ring at a frequency at least
 partially reflecting the relative priority of the logical rings.

7. The method of claim 6 further comprising:
 5 determining for each logical ring a number of bytes held by all the
 connection buffers within that ring (nBytes);
 determining for each ring the number of connection buffers it holds that
 have data waiting to be sent (nReady);
 determining a number of bytes to be sent from each logical ring.

10 8. The method of claim 7 wherein the step of determining the
 number of bytes comprises normalizing to the logical ring having the largest
 nBytes value.

9. The method of claim 7 wherein number of logical rings is "n"
 defining n discrete priority levels labeled 0 to n-1, and the step of selecting
 15 further comprises:

selecting sub-packets from each of the rings in having a selection
 pattern substantially matching:

	selection round	logical ring
	1	n
20	2	n, n-1
	3	n, n-1, n-2
	n	n, n-1, n-2,...,n-1.

10. The method of claim 1, wherein the networked computer transmits
 the prioritized packets to a second networked computer over the Internet.

25 11. The method of claim 1, wherein the networked computer receives
 the prioritized packets from at least one client.

12. The method of claim 1, wherein the prioritized packets are
 received by an originating server.

13. The method of claim 1, wherein the networked computer transmits the prioritized packets to a second networked computer and receives prioritized packets from the second networked computer.

5 14. The method of claim 1 wherein the act of determining the priority value comprises:
parsing the data sets; and
determining the priority value at least partially based on the parsed data sets.

10 15. The method of claim 1 wherein the act of determining the priority value comprises:
receiving prioritization rules from an external content server associated with at least one of the data sets; and
determining the priority value at least partially based on the prioritization rules.

15 16. A system for transmitting packets from a buffer of a network computer onto a network, said system comprising:
a buffer to store a plurality of packets received from at least one client;
at least two packets stored in the buffer, wherein each of the packets has a priority value that at least partially determines a queue order for
20 transmitting; and
a transmitter to transmit prioritized packets from the buffer.

25 17. The system of claim 16 wherein:
the buffer is part of an intermediary web server that receives packets from the at least one client; and
the network is the Internet.

18. The system of claim 16 wherein the priority value is based on at least two priority parameter values for the at least one packet, wherein the at least two priority parameter values are converted into a priority value based on a weighting algorithm.

19. The system of claim 16, wherein the priority value is at least partially determined by the number of transmission cycles each of the at least two packets has remained in the buffer.

5 20. The system of claim 16, wherein the networked computer transmits the prioritized packets to a second networked computer over the Internet.

21. The system of claim 16, wherein the prioritized packets are received by an originating server.

10 22. The system of claim 16, wherein the networked computer transmits the prioritized packets to a second networked computer and receives prioritized packets from the second networked computer.

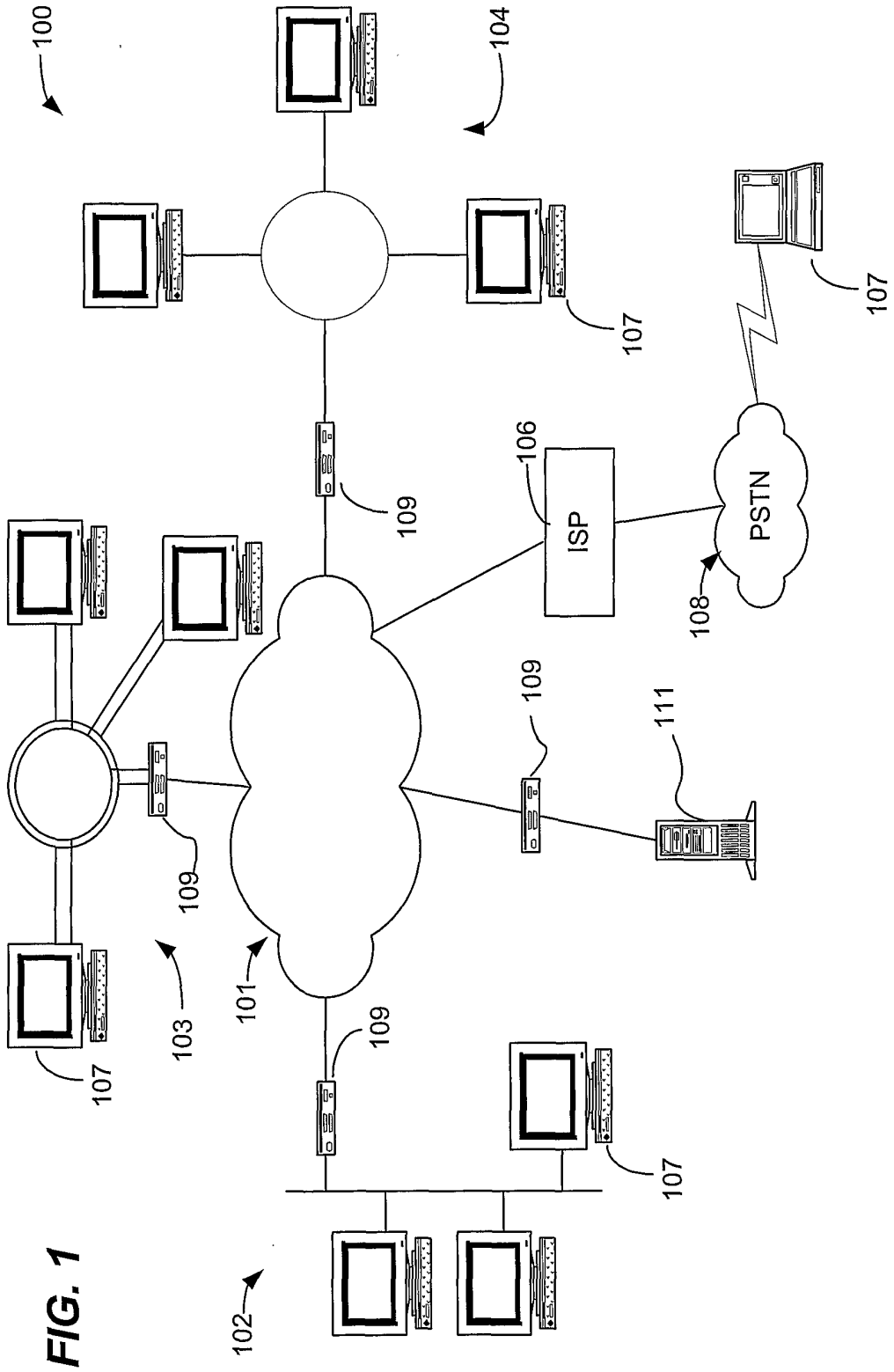

FIG. 1

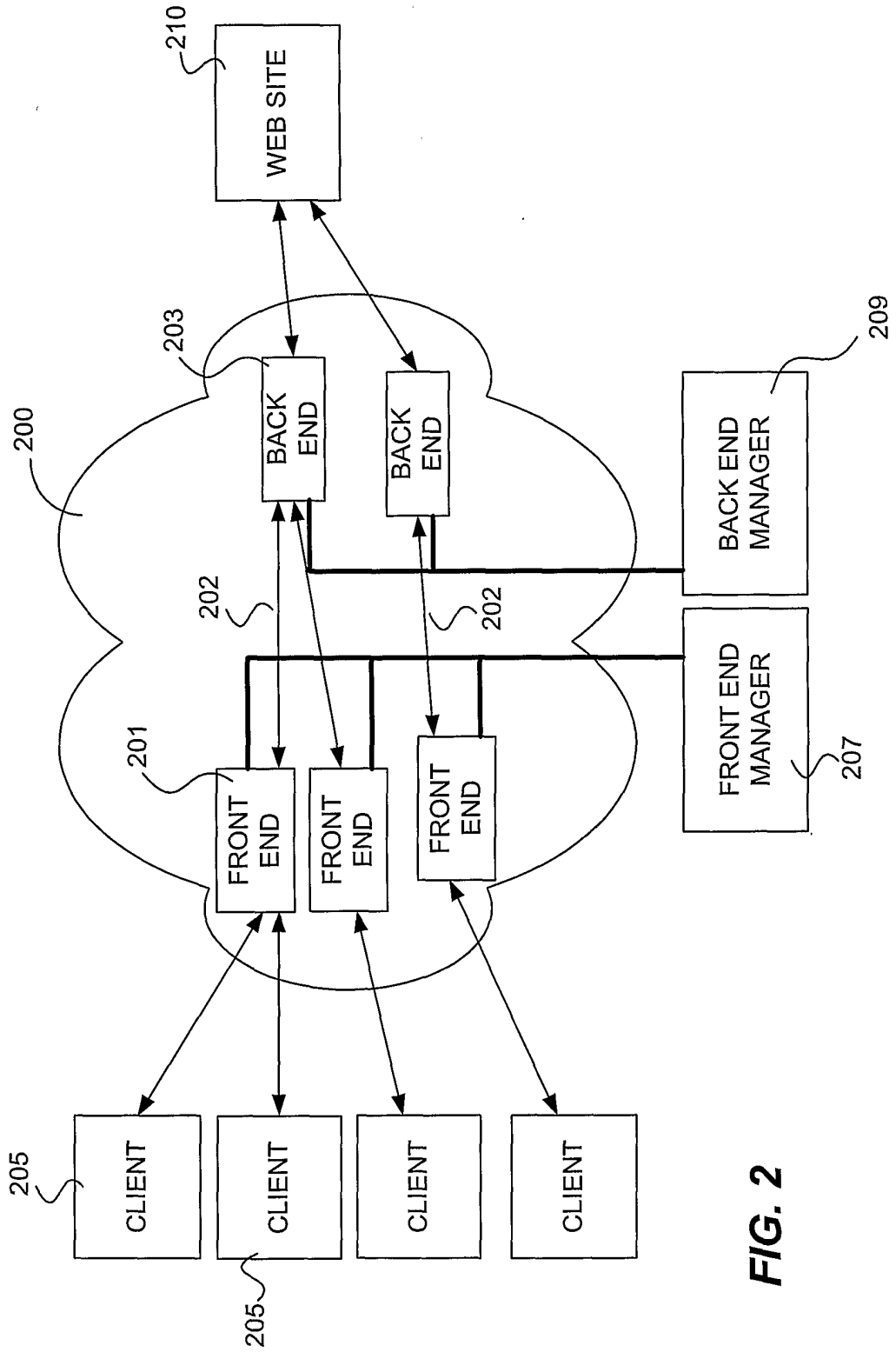

FIG. 2

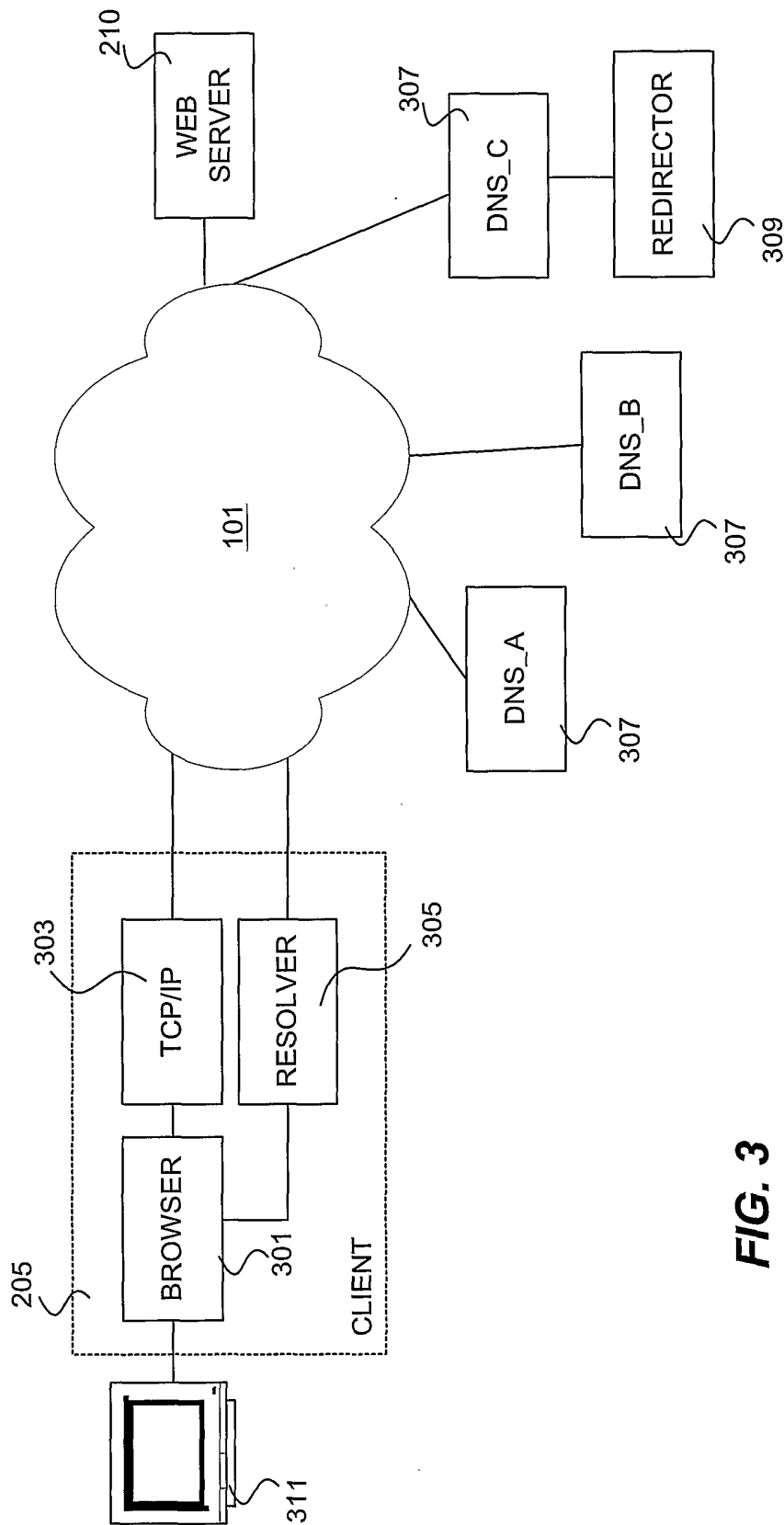

FIG. 3

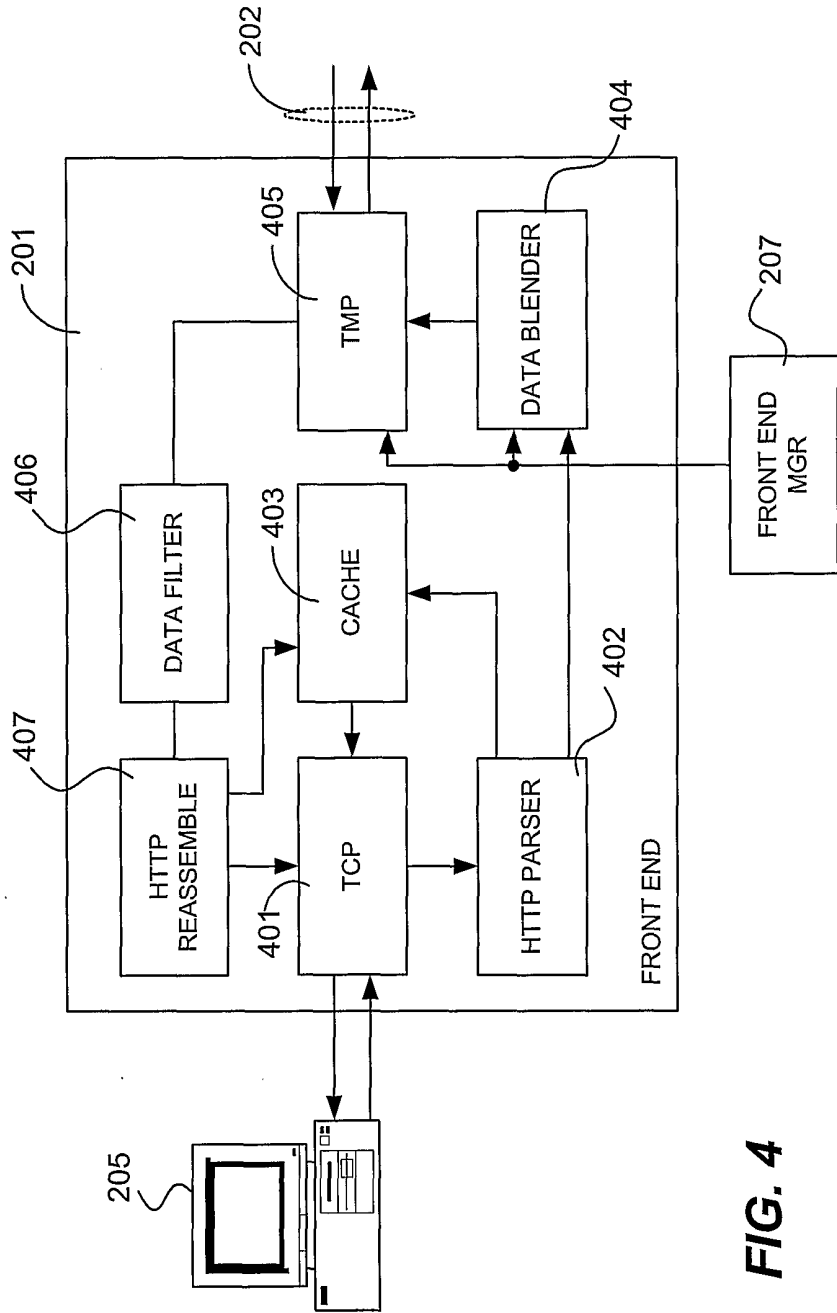

FIG. 4

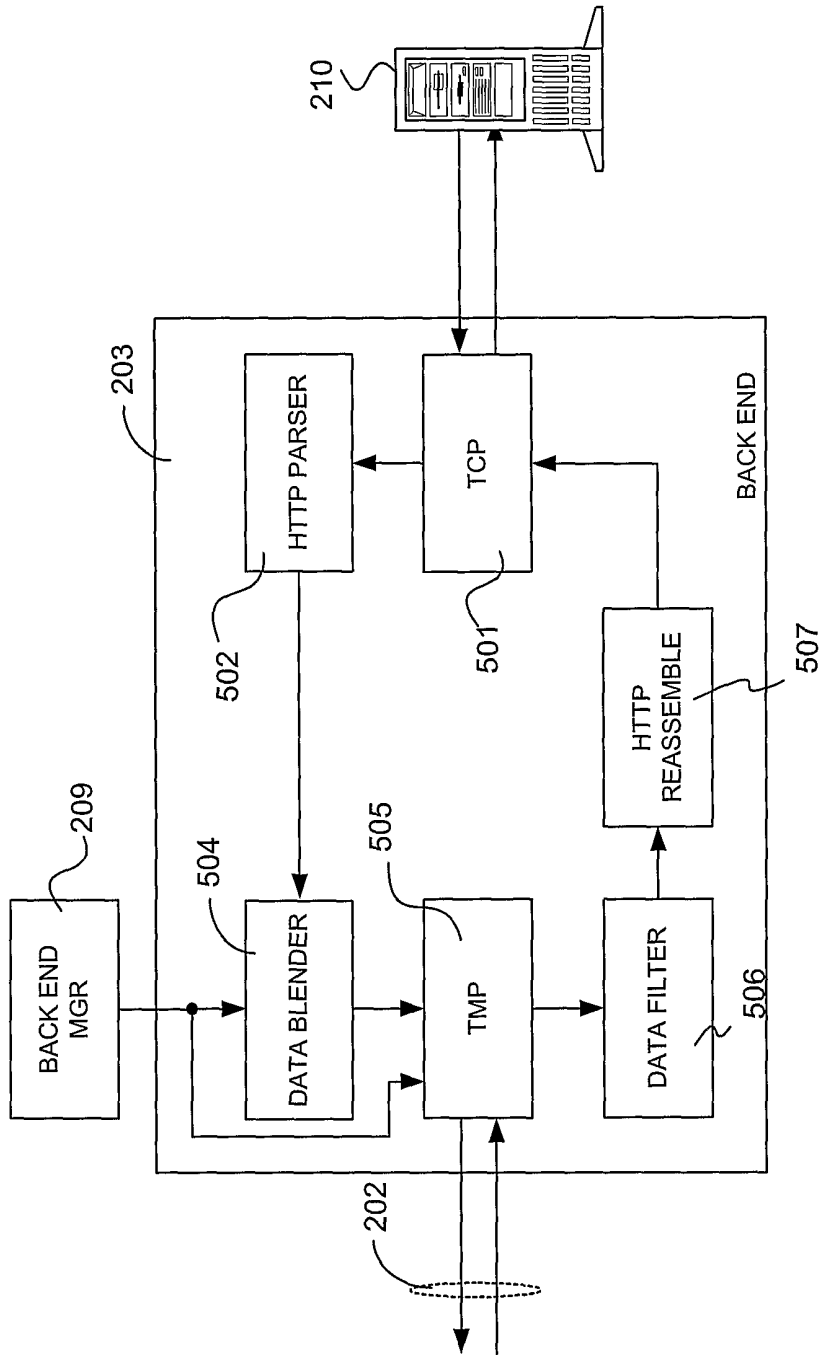

FIG. 5

6/9

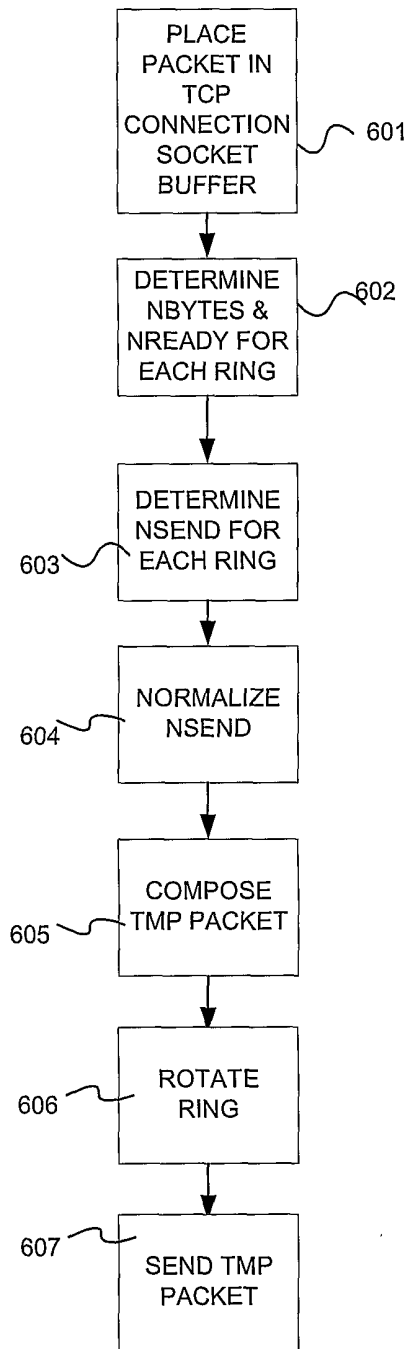

FIG. 6

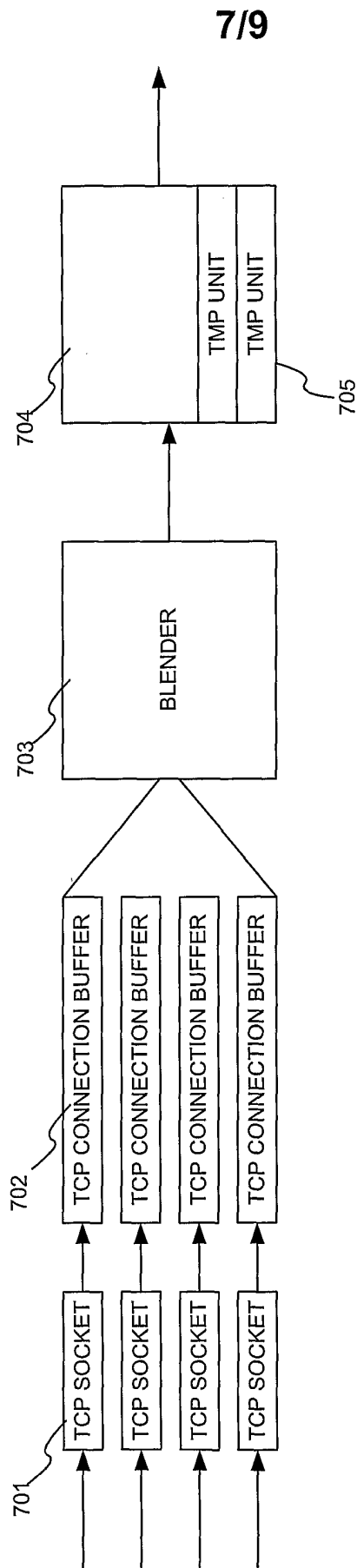

FIG. 7

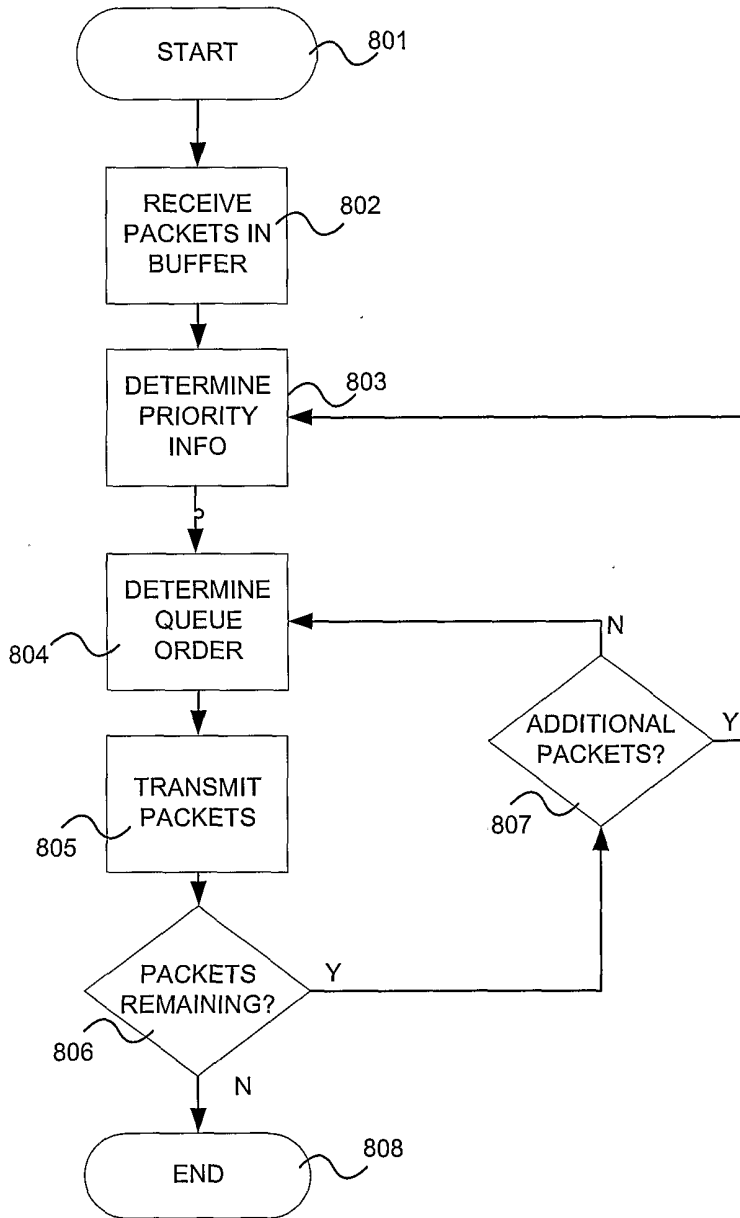

FIG. 8

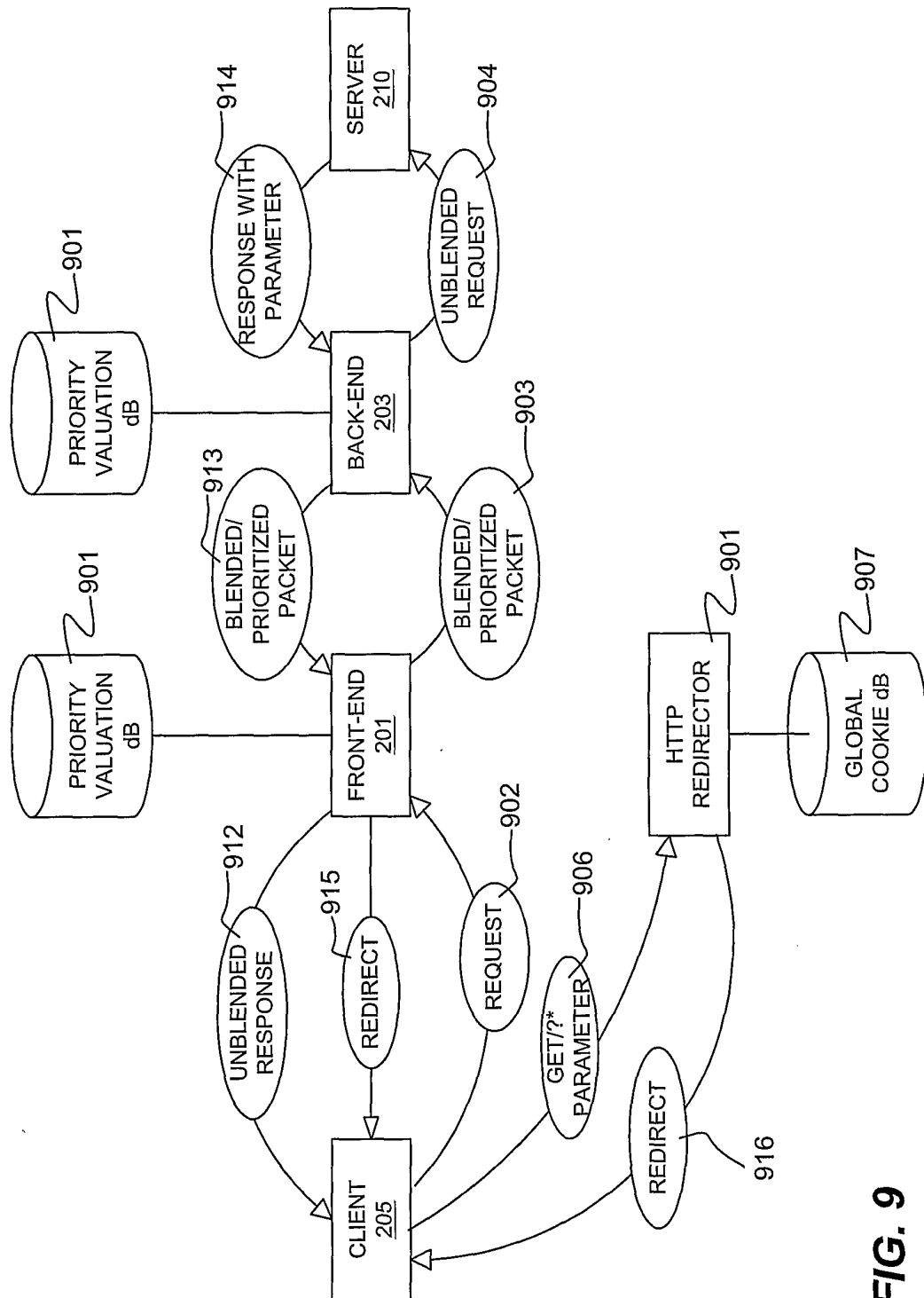

FIG. 9