



(51) International Patent Classification:

H02S 20/20 (2014.01) H02S 20/30 (2014.01)
H02S 20/10 (2014.01)

(21) International Application Number:

PCT/US2015/042544

(22) International Filing Date:

28 July 2015 (28.07.2015)

(25) Filing Language:

English

(26) Publication Language:

English

(30) Priority Data:

14/446,003 29 July 2014 (29.07.2014) US
62/084,550 25 November 2014 (25.11.2014) US
62/167,842 28 May 2015 (28.05.2015) US

(72) Inventor; and

(71) Applicant : **KORNOVICH, Lonnie L.** [US/US]; 4478 -
121st Ave, Clear Lake, MN 55319 (US).

(74) Agent: **WATKINS, Albert W.**; Quill & Disc, Inc., 30844
1st Ave NE, Saint Joseph, MN 56374 (US).

(81) Designated States (unless otherwise indicated, for every

kind of national protection available): AE, AG, AL, AM, AO, AT, AU, AZ, BA, BB, BG, BH, BN, BR, BW, BY, BZ, CA, CH, CL, CN, CO, CR, CU, CZ, DE, DK, DM, DO, DZ, EC, EE, EG, ES, FI, GB, GD, GE, GH, GM, GT, HN, HR, HU, ID, IL, IN, IR, IS, JP, KE, KG, KN, KP, KR, KZ, LA, LC, LK, LR, LS, LU, LY, MA, MD, ME, MG, MK, MN, MW, MX, MY, MZ, NA, NG, NI, NO, NZ, OM, PA, PE, PG, PH, PL, PT, QA, RO, RS, RU, RW, SA, SC, SD, SE, SG, SK, SL, SM, ST, SV, SY, TH, TJ, TM, TN, TR, TT, TZ, UA, UG, US, UZ, VC, VN, ZA, ZM, ZW.

(84) Designated States (unless otherwise indicated, for every

kind of regional protection available): ARIPO (BW, GH, GM, KE, LR, LS, MW, MZ, NA, RW, SD, SL, ST, SZ, TZ, UG, ZM, ZW), Eurasian (AM, AZ, BY, KG, KZ, RU, TJ, TM), European (AL, AT, BE, BG, CH, CY, CZ, DE, DK, EE, ES, FI, FR, GB, GR, HR, HU, IE, IS, IT, LT, LU, LV, MC, MK, MT, NL, NO, PL, PT, RO, RS, SE, SI, SK, SM, TR), OAPI (BF, BJ, CF, CG, CI, CM, GA, GN, GQ, GW, KM, ML, MR, NE, SN, TD, TG).

Declarations under Rule 4.17:

— of inventorship (Rule 4.17(iv))

[Continued on next page]

(54) Title: UTILITY POLE MOUNTED SOLAR PANELS AND SECURING BRACKETS

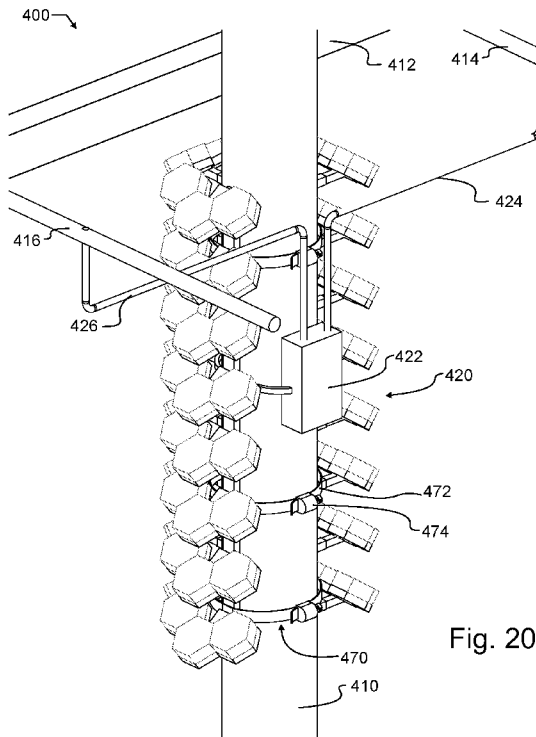

Fig. 20

(57) Abstract: An electrical transmission system has solar electrical generation stations mounted directly to existing utility poles along a transmission line. Solar panels and securing brackets define each solar electric generation station. Each station has at least one generally East facing panel, at least one generally South facing panel, and at least one generally West facing panel. A power coupling conducts electricity generated by the solar electric generation station into the transmission lines. In one embodiment, a plurality of spacer members support the separate and distinct solar collector surfaces in a fixed position relative to the utility pole and have a plurality of clamp passages. A plurality of clamps pass through the clamp passages to guide and retain the clamps. In another embodiment, a plurality of adjustable brackets affix with the spacer members adjacent a first end and to the utility pole adjacent a second end distal to the first end.

WO 2016/018952 A1



Published:

— with international search report (Art. 21(3))

— before the expiration of the time limit for amending the claims and to be republished in the event of receipt of amendments (Rule 48.2(h))

UTILITY POLE MOUNTED SOLAR PANELS AND SECURING BRACKETSTechnical Field

This invention pertains generally to electrical transmission or interconnection systems, and more particularly to such systems having plural supply circuits or sources distributed along a load circuit. In a most preferred manifestation, the present invention provides solar panels and
5 securing brackets that may, for exemplary purposes, be mounted directly to utility poles including but not limited to power line supporting poles and light poles.

Background Art

Conventional electrical power generation is achieved using extremely large generating facilities that typically produce heat through nuclear reaction or by burning combustible matter
10 such as coal, oil, or natural gas. The heat is then used to convert water to pressurized steam, and the pressurized steam used to spin an electricity generating turbine. Next, the electricity is transmitted over great distance from this large central plant to the end user. In the transmission and distribution of electrical energy, there are many utility poles that are anchored into the earth, and power lines strung overhead between adjacent utility poles. In view of the essential nature
15 that electricity plays in the modern world, these utility poles are almost always afforded right-of-way to allow the utility companies to access and maintain the lines.

The efficiency of modern photovoltaic cells is very high, and the cost is quite low. Furthermore, the electricity may be generated at or close to the point of consumption, which may provide lower transmission losses and greater power distribution capacity. Consequently, much
20 opportunity exists to generate a substantial portion of electricity required for everyday use through the generation of electricity using sunlight, referred to in technical circles as solar insolation. Unfortunately, there has always been a divide between the capability to produce power from sunlight and the desire to actually install a system.

There have been several barriers to the adoption of photovoltaic systems. One barrier is
25 the cost of installation. Not only do the solar cells need to be purchased, but they must also be installed in a manner that allows them to withstand the vagaries of the environment. Typically this includes wind and ice loading. Even when properly designed, the solar panels may become

detached in an exceptional wind storm or hurricane, perpetrating damage to the supporting structure. Furthermore, when the solar cells are mounted to an existing building, the very act of installation can and often does harm the building. For example, a roof-mounted system will have fasteners that penetrate the roof of the structure. Over time, these "holes" in the roof may develop leaks that cause far more damage than the system will return in power savings. Consequently, the installation systems are necessarily expensive, and require expertise that in turn translates into high labor costs.

Yet another barrier has been adverse alteration to the aesthetic appearance of a building. The panels are very difficult to incorporate into the appearance of a building, often detracting therefrom. A homeowner or commercial property owner will often forego the installation purely due to aesthetic factors.

However, a utility pole may also be used to support solar cell arrays. In this case, the photovoltaic array does not detract from the appearance of the pole and transmission line, and the utility pole is already securely anchored into the earth. US patent 8,466,581 by Kuran, also published as 2010/0327657 and entitled "System and method for utility pole distributed solar power generation," the teachings and contents which are incorporated herein by reference, shows multiple poles with the one or more PV cells mounted on them, and provides an extensive discussion of the interface between the solar panels and the grid. Unfortunately, the Kuran construction is very exposed, leaving the system vulnerable to wind and ice loading. Furthermore, the panels are oriented for peak power production at or around midday, and so will only produce power for a few hours each day.

In US patent 8,097,980 by Cyrus et al, entitled "Distributed solar power plant and a method of its connection to the existing power grid," the teachings and contents which are incorporated herein by reference, another PV system using utility poles is illustrated. This patent fails to describe how the panels are mounted.

Several additional US patents and published applications illustrate solar cells coupled with poles, the teachings and contents which are incorporated herein by reference, including 2013/0322063 by Tittle, entitled "Solar retrofit lighting system"; 8,029,154 by Myer, entitled "Solar-powered light pole and LED light fixture"; and 6,060,658 by Yoshida et al, entitled "Pole having solar cells".

Other US patents and published applications, the teachings and contents which are

incorporated herein by reference, illustrate PV panels used to power a light on the pole or other somewhat less relevant concepts, but that nevertheless represent the state of the industry and provide a representation of the level of skill in the field: 4,200,904 by Doan, entitled "Solar powered street lighting system"; 4,281,369 by Batte, entitled "Method and apparatus for solar power lighting"; 4,319,310 by Kingsley, entitled "Solar signs"; 5,149,188 by Robbins, entitled "Solar powered exterior lighting system"; 5,155,668 by Tanner et al, entitled "Solar powered lamp utilizing cold cathode fluorescent illumination and method of facilitating same"; 7,976,180 by Haun et al, entitled "Solar powered rechargeable street light with tamper resistant networkable system"; 7,980,725 by Yu et al, entitled "Solar energy street lamp structure with air passageway"; 7,988,320 by Brumels, entitled "Lighting device having adjustable solar panel bracket"; 7,997,754 by Zhang et al, entitled "Solar component and devices containing the same"; 8,007,124 by Kim, entitled "Self-generating streetlight"; 8,097,980 by Cyrus et al, entitled "Distributed solar power plant and a method of its connection to the existing power grid"; 8,106,593 by Nevins, entitled "Hybrid lighting device"; 8,215,807 by Brunesti, entitled "Illuminating flagpole assembly"; 8,246,207 by Chen et al, entitled "LED solar traffic marking panel fitted with integrated dimming controller"; 8,267,541 by Watanabe et al, entitled "Outdoor illuminating device and illuminating method"; 8,313,210 by Zheng, entitled "Solar-powered LED indicator lamp"; 8,342,706 by Zheng, entitled "LED lamp"; 2008/0137327 by Hodulik, entitled "Grid-tied solar streetlighting"; 2013/0118555 by Samuels, entitled "Solar energy collectors and methods for capturing solar energy"; and 2013/0234605 by Burrows, entitled "Hybrid outdoor streetlamp assembly".

In addition to the foregoing patents, Webster's New Universal Unabridged Dictionary, Second Edition copyright 1983, is incorporated herein by reference in entirety for the definitions of words and terms used herein.

Disclosure of Invention

In a first manifestation, the invention is an electrical transmission system having plural electrical supply sources distributed along one or more load circuits carried by one or more transmission lines. A utility pole suspends transmission lines. At least one solar electric generation station supplies electrical energy and has at least three separate and distinct solar collector surfaces, defined by at least one generally East facing panel, at least one generally South

facing panel, and at least one generally West facing panel. A plurality of spacer members support the at least three separate and distinct solar collector surfaces in a fixed position relative to the utility pole and have a plurality of clamp passages. A plurality of clamps are adapted to operatively pass through the plurality of clamp passages which are adapted to operatively guide and retain the plurality of clamps. A power coupling conducts electricity generated by the at least one solar electric generation station into the transmission lines.

In a second manifestation, the invention is an electrical transmission system having plural electrical supply sources distributed along one or more load circuits carried by one or more transmission lines. A utility pole suspends transmission lines. At least one solar electric generation station supplies electrical energy and has at least three separate and distinct solar collector surfaces, defined by at least one generally East facing panel, at least one generally South facing panel, and at least one generally West facing panel. A plurality of spacer members support the at least three separate and distinct solar collector surfaces in a fixed position relative to the utility pole. A plurality of adjustable brackets are adapted to operatively affix with the plurality of spacer members adjacent a first end and to the utility pole adjacent a second end distal to the first end. A power coupling conducts electricity generated by the at least one solar electric generation station into the transmission lines.

In a third manifestation, the invention is an electrical transmission system having plural electrical supply sources distributed along one or more load circuits carried by one or more transmission lines. A utility pole suspends transmission lines. At least one solar electric generation station supplying electrical energy has at least one frame member supporting a plurality of individual solar panels on the utility pole. A pivot couples an upper portion of a one of the individual solar panels to the at least one frame member. A slide frame that is adjustable in length is adjacent to a first end affixed to the frame member and adjacent to a second end distal to the first end to one of the individual panels. A change of length of the slide frame causes one of the individual panels to rotate about the pivot and thereby adjusts an angle of orientation of the one of the individual panels relative to the frame member. A power coupling conducts electricity generated by the at least one solar electric generation station into the transmission lines.

Brief Description of the Drawings

The foregoing and other objects, advantages, and novel features of the present invention can be understood and appreciated by reference to the following detailed description of the invention, taken in conjunction with the accompanying drawings, in which:

5 FIG. 1 illustrates a preferred embodiment electrical transmission system designed in accord with the teachings of the present invention from a front elevational view.

FIG. 2 illustrates a preferred embodiment solar electric generation station used in the preferred embodiment electrical transmission system of Figure 1, the present view of Figure 2 taken along section line 2' of Figure 1 to reveal a top plan view of an installed preferred embodiment solar electric generation station.

10 FIG. 3 illustrates a rear elevational view of the preferred embodiment solar electric generation station of Figure 2, but removed from the utility pole and with the screw-based clamps removed therefrom.

FIG. 4 illustrates a first alternative embodiment solar electric generation station used in the preferred embodiment electrical transmission system of Figure 1, the present view of Figure 4 taken along section line 2' to reveal a top plan view of an installed first alternative embodiment solar electric generation station.

FIG. 5 illustrates a rear elevational view of the first alternative embodiment solar electric generation station of Figure 4, but removed from the utility pole.

20 FIG. 6 illustrates a second alternative embodiment electrical transmission system incorporating a second alternative embodiment solar electric generation station from a front projected view.

FIG. 7 illustrates the second alternative embodiment electrical transmission system of Figure 6 from a rear projected view.

25 FIG. 8 illustrates the second alternative embodiment electrical transmission system of Figure 6 from an enlarged front projected view.

FIG. 9 illustrates the second alternative embodiment electrical transmission system of Figure 7 from an enlarged rear projected view.

30 FIG. 10 illustrates the second alternative embodiment electrical transmission system of Figure 6 from an enlarged front projected view, but with the solar photovoltaic panels removed therefrom.

FIGs. 11-13 illustrate a preferred set of spacer members used in the second alternative

embodiment electrical transmission system of Figure 6 from front projected, side, and rear projected views, respectively.

FIGs. 14-16 illustrate a preferred set of solar photovoltaic panels used in the second alternative embodiment electrical transmission system of Figure 6 from top, front, and side views, respectively.

FIG. 17 illustrates a third alternative embodiment electrical transmission system incorporating a third alternative embodiment solar electric generation station from a front projected view.

FIG. 18 illustrates the third alternative embodiment electrical transmission system of Figure 17 from a rear projected view.

FIG. 19 illustrates the third alternative embodiment electrical transmission system of Figure 17 from an enlarged front projected view.

FIG. 20 illustrates the third alternative embodiment electrical transmission system of Figure 18 from an enlarged rear projected view.

FIG. 21 illustrates the third alternative embodiment electrical transmission system of Figure 17 from an enlarged front projected view, but with the solar photovoltaic panels removed therefrom.

FIG. 22 illustrates the third alternative embodiment electrical transmission system of Figure 17 from an enlarged front projected view, but with a second set of solar photovoltaic panels incorporated therein.

FIG. 23 illustrates the third alternative embodiment electrical transmission system of Figure 17 from a schematic view, illustrating the electrical wiring and mechanical coupling to a pole.

Best Mode for Carrying Out the Invention

Manifested in the preferred embodiment illustrated in Figure 1, the present invention provides an electrical transmission system 100 having plural electrical supply sources distributed along one or more load circuits such as carried by transmission lines 114, 116. A typical prior art utility pole 110 may, for exemplary purposes only and not solely limiting thereto be provided with a support arm 112 which suspends transmission lines 114, 116 from utility pole 110 and may provide electrical isolation.

The electrical supply sources are most preferably one or more solar electric generation stations 120. Each solar electric generation station 120 will preferably be provided with a Direct Current (DC) to Alternating Current (AC) inverter 122, which will preferably include various functions, such as the ability to synchronize with the power grid and the ability to disconnect therefrom in the event of a power failure such as a downed transmission line or other electrical transmission system 100 failure. These inverters are well known in the field of solar electric generation and widely commercially available, and further discussed in the patents incorporated herein by reference.

While a DC to AC inverter 122 is preferred, it will be understood that any suitable method of coupling electricity generated by solar electric generation station 120 into inverter output lines 124, 126 and from there to transmission lines 114, 116 will be understood to be incorporated herein. Consequently, inverter 122 might not perform any conversion from DC to AC, and may instead be a simple switch that allows solar electric generation station 120 to be disconnected from transmission lines 114, 116 in the event a repair is required within electrical transmission system 100, to protect the safety of a technician.

Preferred embodiment solar electric generation station 120 has three separate and distinct solar collector surfaces, defined by East facing panel 132, South facing panel 134, and West facing panel 136. These panels 132, 134, 136 may be curved, such as illustrated in Figure 2, in which case they will either have photovoltaic cells deposited or otherwise formed thereon, or will have flexible photovoltaic panels affixed thereto. Alternatively, panels 132, 134, 136 may each be planar, and angularly offset from each other to face approximately East, South, and West, respectively. While three panels are illustrated for exemplary purposes, it will be understood that more or fewer panels may be used, though three are illustrated.

By providing these three panels 132, 134, 136, solar electric generation station 120 does not require a tracking mount, and is still capable of producing electricity throughout the daylight hours. Several manufacturers are able to produce solar cells that are of sufficiently low cost that the benefit from a tracking mount in increased power output throughout a daily cycle is not sufficient to justify the added expense and maintenance of the tracking components. Solar electric generation station 120 additionally is defined by a bottom 131, a top 133, an exterior face 135, and an interior face 137. As may be appreciated, exterior face 135 will preferably have one or more solar cells either formed in place or mounted thereon. For exemplary purposes only, and

not solely limiting the invention thereto, exterior face 135 may have a Copper Indium Gallium Selenide (CIGS) thin film material, which is easily deposited onto flexible substrates, wrapped or glued to the exterior face or may in another extreme have many small fixed flat glass panels or panes containing mono-crystalline photovoltaic cells angularly stepped about utility pole 110.

5 Preferred embodiment solar electric generation station 120 is illustrated in greater detail in Figures 2 and 3. Supporting the three panels 132, 134, 136 in a fixed position relative to utility pole 110 are a plurality of spacer members, such as spacer members 142, 144, 146, 148. The number and location of these spacer members 142, 144, 146, 148 is not critical to the present invention, and will be determined when a number of design factors are taken into consideration.

10 For exemplary and non-limiting purposes, factors such as wind, ice and snow loading may be used to determine a maximum load that might be placed upon preferred embodiment solar electric generation station 120. Once the maximum load is determined, then the type of material, the thickness and geometry, and other such design computations may be made. Preferably, a plurality of screw-based clamp passages 152, 154, 156 are also provided which serve to guide and retain a plurality of screw-based clamps 170 that may for exemplary purposes include a perforated strap 172, fixed screw mount 174, and worm-drive screw 176. This type of screw-based clamp 170 is commercially referred to as metal banding with worm gear type adjustment screws, and is commonly sold as hose and pipe clamp and for other purposes by such vendors as Vertex Distribution of Attleboro, Massachusetts, Signs Direct of Bloomington, Illinois, and

15 MOWCO Industry Limited of Shenzhen, China. While other types of clamps may be provided in association with preferred embodiment solar electric generation station 120, including but not limited to other types of strap, band, and even webbing, screw-based clamp 170 provides very rapid, secure, intuitive, familiar, and low-cost coupling to utility pole 110, which is preferred to decrease the cost of installation and maintenance.

20 For many installations, the clamping force generated by screw-based clamp 170 will be sufficient to adequately support solar electric generation station 120. However, and particularly for coupling with wooden utility poles, one or more gripping teeth 162, 164, 166, 168 may be provided that protrude from spacer members 142, 144, 146, 148. The specific geometry of these gripping teeth 162, 164, 166, 168 may be altered to suit the characteristics most desired by a designer, such as penetration depth, inter-tooth spacing, and so forth. Alternatively, gripping teeth 162, 164, 166, 168 may be an alternative material that provides increased adhesion to a

25

30

particular surface, such as a rubber or similar elastomeric material having a relatively high coefficient of friction. Such materials may be useful for coupling with a steel utility pole.

As may be appreciated, preferred embodiment solar electric generation station 120 will be designed to directly attach to most existing utility poles, thereby using the existing utility pole 110 as the main support and as immediate access to the electric power grid. This in turn means that there is minimal mounting hardware required, no special anchoring into the earth, and no special permitting required, since the present electrical transmission system 100 uses existing infrastructure. This in turn means that preferred embodiment electrical transmission system 100 may be produced, installed, and maintained for substantially less capital than required for prior art systems.

The materials used to fabricate preferred embodiment solar electric generation station 120 are not critical to the present invention. For exemplary purposes, a base material used to fabricate panels 132, 134, 136 may be galvanized steel. In such case, the steel may be stamped or otherwise formed to shape, though again the particular method of deriving the shape is not critical to the present invention. As already discussed herein above, photovoltaic cells may be formed upon or affixed to the exterior face 135.

Alternative embodiments of apparatus designed in accord with the present invention have been illustrated in Figures 4 - 23. The embodiments are distinguished by the hundreds digit, and various components within each embodiment designated by the ones and tens digits. However, many of the components are alike or similar between embodiments, so numbering of the ones and tens digits have been maintained wherever possible, such that identical, like or similar functions may more readily be identified between the embodiments. If not otherwise expressed, those skilled in the art will readily recognize the similarities and understand that in many cases like numbered ones and tens digit components may be substituted from one embodiment to another in accord with the present teachings, except where such substitution would otherwise destroy operation of the embodiment. Consequently, those skilled in the art will readily determine the function and operation of many of the components illustrated herein without unnecessary additional description.

Figures 4 and 5 illustrate a first alternative embodiment solar electric generation station 220. In this embodiment, rather than using screw-based clamps, a set of adjustable mounting brackets 252, 254, 256, 258 are used to terminate spacer members 242, 244, 246, 248. The

adjustable mounting brackets 252, 254, 256, 258 may, for exemplary purposes only and not solely limiting thereto, comprise L-shaped brackets that bolt, screw or otherwise affix to spacer members 242, 244, 246, 248, and also bolt, screw or otherwise affix at a distal end to utility pole 110. This method of attachment is limited, since adjustable mounting brackets 252, 254, 256, 258 are adjacent to interior face 237 and therefore hard to access. Nevertheless, adjustable mounting brackets 252, 254, 256, 258 may be provided near to the top and bottom of solar electric generation station 220, and in such case sufficient access clearance will exist.

While the embodiments of Figures 2 and 4 each illustrate the spacing between utility pole 110 and exterior face 135, 235 as being equidistant at both bottom 131, 231 and top 133, 233, the present invention also contemplates changing the spacing to suit a particular application. The present invention may be readily modified to optimize solar incidence upon the solar electric generation station at various latitudes and for various times of day.

At sunrise and sunset, the solar rays are arriving in a nearly horizontal plane. In this case, the spacing between utility pole 110 and the exterior face 135 adjacent to top 133 and East facing panel 132 may be approximately equal to the spacing between utility pole 110 and the exterior face 135 adjacent to bottom 131 and East facing panel 132. This means that East facing panel 132 is oriented in an approximately vertical plane, which may be appropriate for morning and evening solar exposure. Consequently, West facing panel 136 may also be oriented in an approximately vertical plane. However, except at the most northern latitudes, at midday the solar rays will be traveling at some angle generally between horizontal and vertical, such as at between 33 and 66 degrees from horizontal. To better align South facing panel 134 with the approximately midday sun, and thereby improve the collection of midday solar radiation and solar electric generation, South facing panel 134 may also be tilted from vertical. While not illustrated, it will be apparent that the spacing between utility pole 110 and the exterior face 135 adjacent to top 133 and South facing panel 134 may be very different from the spacing between utility pole 110 and the exterior face 135 adjacent to bottom 131 and South facing panel 134. Similarly, if more than three panels are used to define solar electric generation station 120, the panels that are more south facing may also tilt more out of the vertical plane towards the horizontal plane than less south facing panels.

Figures 6 - 16 illustrate a second alternative embodiment electrical transmission system 300 having plural electrical supply sources distributed along one or more load circuits such as

carried by transmission lines 314, 316. A typical prior art utility pole 310 may, for exemplary purposes only and not solely limiting thereto be provided with a support arm 312 which suspends transmission lines 314, 316 from utility pole 310 and may provide electrical isolation.

The electrical supply sources are most preferably one or more solar electric generation stations 320. Each solar electric generation station 320 will preferably be provided with a Direct Current (DC) to Alternating Current (AC) inverter 322, which will preferably include various functions, such as the ability to synchronize with the power grid and the ability to disconnect therefrom in the event of a power failure such as a downed transmission line or other electrical transmission system 300 failure. These inverters are well known in the field of solar electric generation and widely commercially available, and further discussed in the patents incorporated herein by reference.

While a DC to AC inverter 322 is preferred, it will be understood that any suitable method of coupling electricity generated by solar electric generation station 320 into inverter output lines 324, 326 and from there to transmission lines 314, 316 will be understood to be incorporated herein. Consequently, inverter 322 might not perform any conversion from DC to AC, and may instead be a simple switch that allows solar electric generation station 320 to be disconnected from transmission lines 314, 316 in the event a repair is required within electrical transmission system 300, to protect the safety of a technician.

Preferred embodiment solar electric generation station 320 has a plurality of separate and distinct solar collector surfaces 336. These panels 336 may be curved, in which case they will either have photovoltaic cells deposited or otherwise formed thereon, may have flexible photovoltaic panels affixed thereto, or may be fabricated in smaller flat support segments 345 such as illustrated in Figures 14 - 16. In the embodiment as illustrated, panels 336 may each be planar, and angularly offset from each other to face approximately East, South and West, respectively. While three panels are illustrated for exemplary purposes, it will be understood that more or fewer panels may be used, though three are illustrated.

By providing these three panels 336, solar electric generation station 320 does not require a tracking mount, and is still capable of producing electricity throughout the daylight hours. Several manufacturers are able to produce solar cells that are of sufficiently low cost that the benefit from a tracking mount in increased power output throughout a daily cycle is not sufficient to justify the added expense and maintenance of the tracking components.

Preferred embodiment solar electric generation station 320 is illustrated in greater detail in Figures 7 - 9. Supporting the panels 336 in a fixed position relative to utility pole 310 are a plurality of spacer members 342. The number and location of these spacer members 342 is not critical to the present invention, and will be determined when a number of design factors are taken into consideration. For exemplary and non-limiting purposes, factors such as wind, ice and snow loading may be used to determine a maximum load that might be placed upon preferred embodiment solar electric generation station 320. Once the maximum load is determined, then the type of material, the thickness and geometry, and other such design computations may be made. Preferably, a plurality of screw-based clamp passages 352, 354, 356 are also provided which serve to guide and retain a plurality of screw-based clamps 370 that may for exemplary purposes include a perforated strap 372, fixed screw mount 374, and worm-drive screw. While other types of clamps may be provided in association with preferred embodiment solar electric generation station 320, including but not limited to other types of strap, band, and even webbing, screw-based clamp 370 provides very rapid, secure, intuitive, familiar, and low-cost coupling to utility pole 310, which is preferred to decrease the cost of installation and maintenance.

As may be appreciated, preferred embodiment solar electric generation station 320 will be designed to directly attached to most existing utility poles, thereby using the existing utility pole 310 as the main support and as immediate access to the electric power grid. This in turn means that there is minimal mounting hardware required, no special anchoring into the earth, and no special permitting required, since the present electrical transmission system 300 uses existing infrastructure. This in turn means that preferred embodiment electrical transmission system 300 may be produced, installed, and maintained for substantially less capital than required for prior art systems.

Figures 17 - 23 illustrate a third alternative embodiment electrical transmission system 400 having plural electrical supply sources distributed along one or more load circuits such as carried by transmission lines 414, 416. A typical prior art utility pole 410 may, for exemplary purposes only and not solely limiting thereto be provided with a support arm 412 which suspends transmission lines 414, 416 from utility pole 410 and may provide electrical isolation.

The electrical supply sources are most preferably one or more solar electric generation stations 420. Each solar electric generation station 420 will preferably be provided with a Direct Current (DC) to Alternating Current (AC) inverter 422, which will preferably include various

functions, such as the ability to synchronize with the power grid and the ability to disconnect therefrom in the event of a power failure such as a downed transmission line or other electrical transmission system 400 failure. These inverters are well known in the field of solar electric generation and widely commercially available, and further discussed in the patents incorporated
5 herein by reference.

While a DC to AC inverter 422 is preferred, it will be understood that any suitable method of coupling electricity generated by solar electric generation station 420 into inverter output lines 424, 426 and from there to transmission lines 414, 416 will be understood to be incorporated herein. Consequently, inverter 422 might not perform any conversion from DC to
10 AC, and may instead be a simple switch that allows solar electric generation station 420 to be disconnected from transmission lines 414, 416 in the event a repair is required within electrical transmission system 400, to protect the safety of a technician.

Preferred embodiment solar electric generation station 420 has a plurality of separate and distinct solar collector panels 436. These panels 436 are preferably fabricated to support a
15 plurality of smaller hexagonal Concentrated PhotoVoltaic (CPV) modules 445, such as are available for exemplary purpose from Morgan Solar of Toronto, Canada, though other geometries and types of photovoltaic cells may be used. In the embodiment as illustrated, panels 436 may each be planar, are illustrated as having a geometry supporting three CPV modules 445 on each panel 436, and are angularly repeating about pole 410 to face approximately East, South and
20 West, respectively. While three panel directions are illustrated for exemplary purposes, it will be understood that more or fewer panels 436 may be used, though three are illustrated. Likewise, more or fewer than three CPV modules 445 may be supported on each panel 436.

By providing these panels 436, solar electric generation station 420 does not require a tracking mount, and is still capable of producing electricity throughout the daylight hours.
25 Several manufacturers are able to produce solar cells that are of sufficiently low cost that the benefit from a tracking mount in increased power output throughout a daily cycle is not sufficient to justify the added expense and maintenance of the tracking components.

Preferred embodiment solar electric generation station 420 is illustrated in further detail in Figures 18 - 23. Supporting panels 436 in a fixed position relative to utility pole 410 are a
30 plurality of frame members 442 visible in Figure 23. Frame members 442 preferably comprise hollow members, such as four-sided tubes of metal or the like. The size, wall thickness, number,

and location of these frame members 442 is not critical to the present invention, and will be determined when a number of design factors are taken into consideration. For exemplary and non-limiting purposes, factors such as wind, ice and snow loading may be used to determine a maximum load that might be placed upon preferred embodiment solar electric generation station 420. Once the maximum load is determined, then the type of material, the thickness and geometry, and other such design computations may be made. A plurality of screw-based clamps 470 that may for exemplary purposes include a perforated strap 472, fixed screw mount 474, and worm-drive screw are used to secure frame members 442 to pole 410. While other types of clamps may be provided in association with preferred embodiment solar electric generation station 420, including but not limited to other types of strap, band, and even webbing, screw-based clamp 470 provides very rapid, secure, intuitive, familiar, and low-cost coupling to utility pole 410, which is preferred to decrease the cost of installation and maintenance. Where utility pole 410 is fabricated from wood, a plurality of gripping teeth or spikes 462 may be affixed, for exemplary but non-limiting purpose to frame members 442.

Each frame member 442 may support a number of individual panels 436, such as illustrated in Figure 23. Individual panels 436 may optionally and as illustrated are preferably configured for angular adjustment using a combination of an adjustable slide frame 447 and a pivot 449, also visible in Figure 23. Pivot 449 might, for exemplary and non-limiting purposes, be comprised by a simple hinge. Adjustable slide frame 447 can be any suitable member that permits length adjustment known in the hardware arts. For exemplary purposes only, and not solely limiting the invention thereto, adjustable slide frame 447 may be comprised of two strips of metal, one with a circular hole and the other with a slot, and a small bolt and wing nut used to lock the two strips of metal together. Pivot 449 couples an upper portion of panel 436 to frame 442. Adjustable slide frame 447 is affixed adjacent to one end to frame 442 and adjacent the other end to panel 436. Adjustable slide frame 447 may then be shortened or lengthened, causing panel 436 to rotate about pivot 449, to adjust the angle of orientation of each CPV module 445.

Adjusting the length of adjustable slide frame 447 can be used to adjust for seasonal variances, but would most commonly be only adjusted once, at the time of installation, to compensate for latitudinal variances between different installation sites. Furthermore, preferred angular orientation will vary around pole 410. For exemplary purposes, panels 436 facing directly east and west will be more nearly vertical than those facing south, corresponding to the

angle of incidence of the sunlight for the compass orientation of the individual panel. This adjustable length is also beneficial for shipping prior to installation, since individual panels 436 may be laid flat against the supporting frame member 442.

Figure 21 illustrates solar collector panels 436 without or prior to installation of CPV modules 445. Each panel 436 in the preferred embodiment is provided with three support surface regions 482, 484, 486, each of the support surface regions which are adapted to receive a CPV module 445. Extending from the center support surface region 484 is a tab 488 containing a wire raceway 443 which provides electrical connection to each one of the CPV modules 445 mounted upon panel 436.

Figure 22, which is very similar to Figure 17, illustrates the addition of a second solar electric generation station 420', simply by mounting solar electric generation station 420' on utility pole 410 just below solar electric generation station 420. The output from solar electric generation station 420' may be joined with the output from solar electric generation station 420 simply by coupling the wires therewith, or, if so desired, by coupling directly into inverter 422.

As may be appreciated, preferred embodiment solar electric generation station 420 will be designed to directly attached to most existing utility poles, thereby using the existing utility pole 410 as the main support and as immediate access to the electric power grid. This in turn means that there is minimal mounting hardware required, no special anchoring into the earth, and no special permitting required, since the present electrical transmission system 400 uses existing infrastructure. This in turn means that preferred embodiment electrical transmission system 400 may be produced, installed, and maintained for substantially less capital than required for prior art systems.

Industrial Applicability

Exemplary embodiments of the present invention solve inadequacies of the prior art by providing solar panels and securing brackets that define solar electric generation stations. These solar electric generation stations mount to existing utility poles to define an electrical transmission system.

The present invention and the preferred and alternative embodiments have been developed with a number of objectives in mind. While not all of these objectives are found in every embodiment, these objectives nevertheless provide a sense of the general intent and the

many possible benefits that are available from embodiments of the present invention.

A first object of the invention is to provide a solar electric generation station that may be directly attached to most existing utility poles, thereby using the existing utility pole as the main support and as immediate access to the electric power grid. A second object of the invention is to provide a solar electric generation station that is easily installed upon the utility pole. Another object of the present invention is to provide a solar electric generation station that does not require a tracking mount, and yet which is capable of producing electricity throughout the daylight hours. A further object of the invention is to reduce the capital outlay required for a solar electric generation station and avoid the need for special permitting by using existing utility poles as the main support. Yet another object of the present invention is to readily enable design variations to optimize solar incidence upon the solar electric generation station at various latitudes.

While the foregoing details what is felt to be the preferred embodiment of the invention, no material limitations to the scope of the claimed invention are intended. Further, features and design alternatives that would be obvious to one of ordinary skill in the art are considered to be incorporated herein. The scope of the invention is set forth and particularly described in the claims herein below.

CLAIMS

I claim:

1. An electrical transmission system having plural electrical supply sources distributed along one or more load circuits carried by one or more transmission lines, comprising:
 - a utility pole suspending transmission lines;
 - at least one solar electric generation station supplying electrical energy and having at least three separate and distinct solar collector surfaces, defined by at least one generally East facing panel, at least one generally South facing panel, and at least one generally West facing panel;
 - a plurality of spacer members supporting said at least three separate and distinct solar collector surfaces in a fixed position relative to said utility pole and having a plurality of clamp passages;
 - a plurality of clamps adapted to operatively pass through said plurality of clamp passages which are adapted to operatively guide and retain said plurality of clamps; and
 - a power coupling that conducts electricity generated by said at least one solar electric generation station into said transmission lines.
2. The electrical transmission system of claim 1, wherein said plurality of clamps further comprises a plurality of screw-based clamps.
3. The electrical transmission system of claim 2, wherein individual ones of said plurality of screw-based clamps further comprise a perforated strap; a fixed screw mount; and a worm-drive screw.
4. The electrical transmission system of claim 1, wherein each individual one of said plurality of spacer members further comprise at least one gripping tooth that protrudes from said spacer member.
5. The electrical transmission system of claim 4, wherein said at least one gripping tooth further

comprises a utility pole surface penetrating point.

6. The electrical transmission system of claim 4, wherein said at least one gripping tooth further comprises a material that provides increased adhesion to said utility pole.

7. The electrical transmission system of claim 1, wherein said power coupling further comprises a Direct Current (DC) to Alternating Current (AC) inverter.

8. The electrical transmission system of claim 7, wherein said power coupling further comprises a disconnect switch that allows said solar electric generation station to be disconnected from said transmission lines.

9. An electrical transmission system having plural electrical supply sources distributed along one or more load circuits carried by one or more transmission lines, comprising:

a utility pole suspending transmission lines;

at least one solar electric generation station supplying electrical energy and having at least three separate and distinct solar collector surfaces, defined by at least one generally East facing panel, at least one generally South facing panel, and at least one generally West facing panel;

a plurality of spacer members supporting said at least three separate and distinct solar collector surfaces in a fixed position relative to said utility pole;

a plurality of adjustable brackets adapted to operatively affix with said plurality of spacer members adjacent a first end and to said utility pole adjacent a second end distal to said first end; and

a power coupling that conducts electricity generated by said at least one solar electric generation station into said transmission lines.

10. The electrical transmission system of claim 9, wherein said plurality of adjustable brackets further comprises a plurality of L-shaped brackets.

11. The electrical transmission system of claim 9, wherein each individual one of said plurality

of spacer members further comprise at least one gripping tooth that protrudes from said spacer member.

12. The electrical transmission system of claim 11, wherein said at least one gripping tooth further comprises a utility pole surface penetrating point.

13. The electrical transmission system of claim 11, wherein said at least one gripping tooth further comprises a material that provides increased adhesion to said utility pole.

14. The electrical transmission system of claim 9, wherein said power coupling further comprises a Direct Current (DC) to Alternating Current (AC) inverter.

15. The electrical transmission system of claim 14, wherein said power coupling further comprises a disconnect switch that allows said solar electric generation station to be disconnected from said transmission lines.

16. An electrical transmission system having plural electrical supply sources distributed along one or more load circuits carried by one or more transmission lines, comprising:

a utility pole suspending transmission lines; and

at least one solar electric generation station supplying electrical energy having at least one frame member supporting a plurality of individual solar panels on said utility pole;

wherein the improvement comprises:

a pivot coupling an upper portion of a one of said individual solar panels to said at least one frame member;

a slide frame adjustable in length and adjacent to a first end affixed to said frame member and adjacent to a second end distal to said first end to said one of said individual panels, wherein a change of length of said slide frame causes said one of said individual solar panels to rotate about said pivot and thereby adjusts an angle of orientation of said one of said individual solar panels relative to said frame member; and

a power coupling that conducts electricity generated by said at least one solar electric generation station into said transmission lines.

17. The electrical transmission system of claim 16, wherein said at least one frame member further comprises three separate and distinct frame members having a plurality of solar collector surfaces affixed thereto, defined by at least one generally East facing frame member, at least one generally South facing frame member, and at least one generally West facing frame member.

18. The electrical transmission system of claim 16, wherein said at least three separate and distinct frame members each further comprise more than three solar collector surfaces used to define solar electric generation station, said panels that are more south facing also tilting more out of the vertical plane towards a horizontal plane than less south facing panels.

1/17

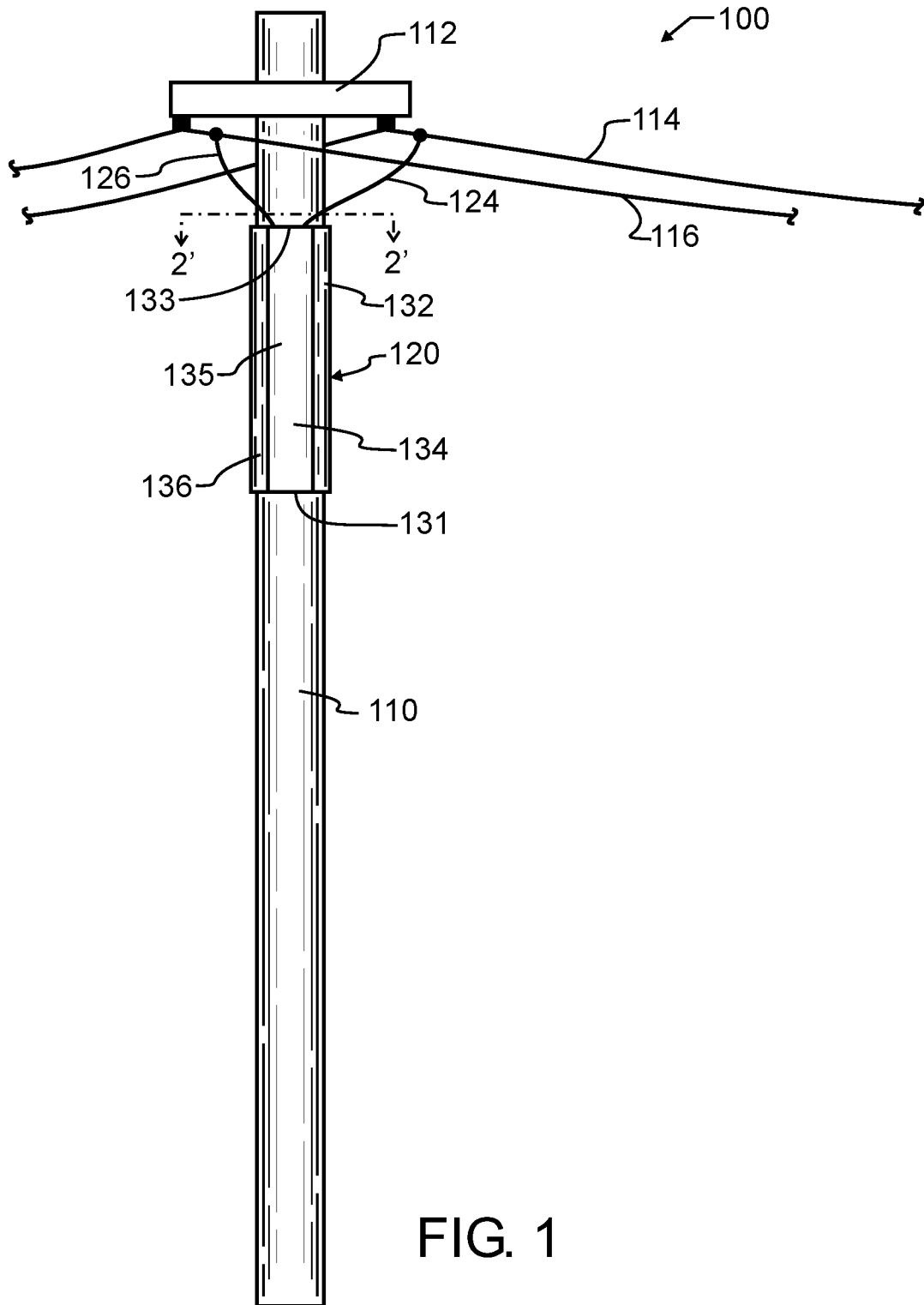

FIG. 1

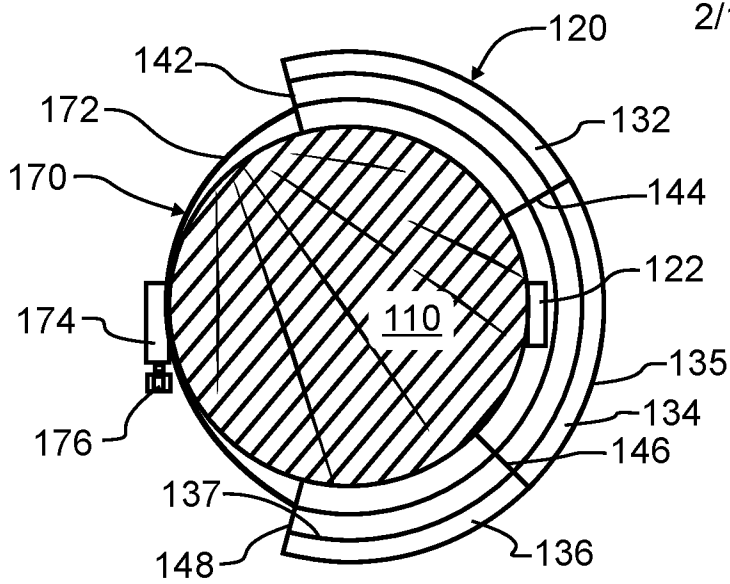

FIG. 2

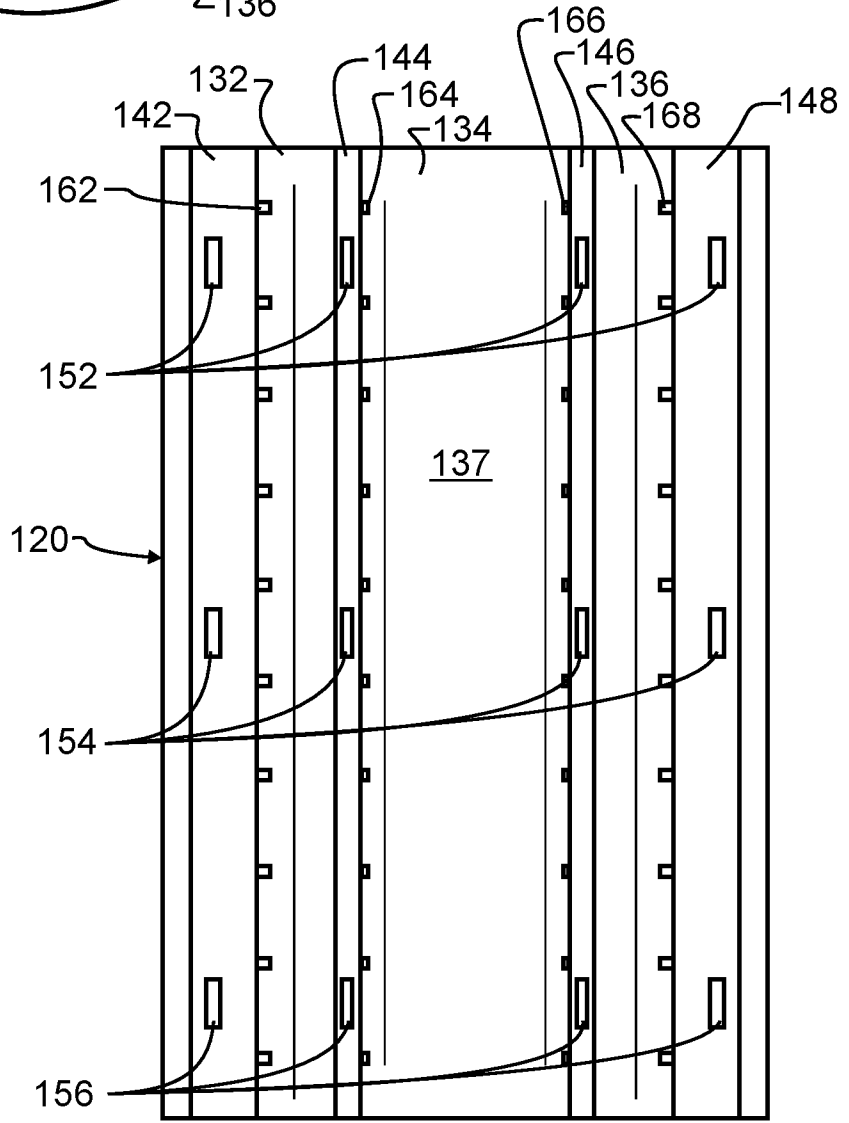

FIG. 3

3/17

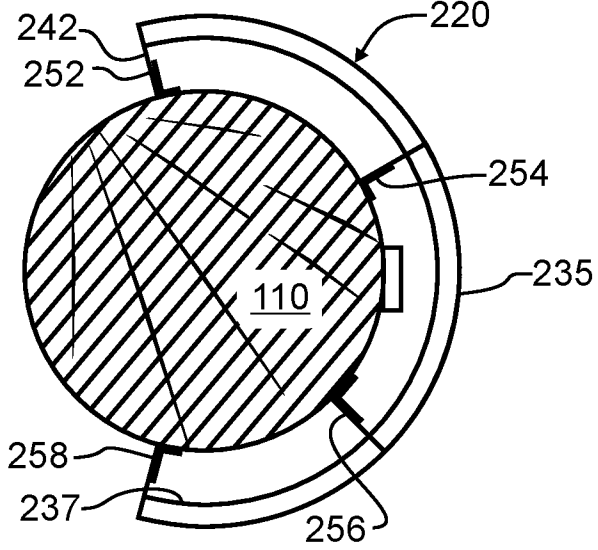

FIG. 4

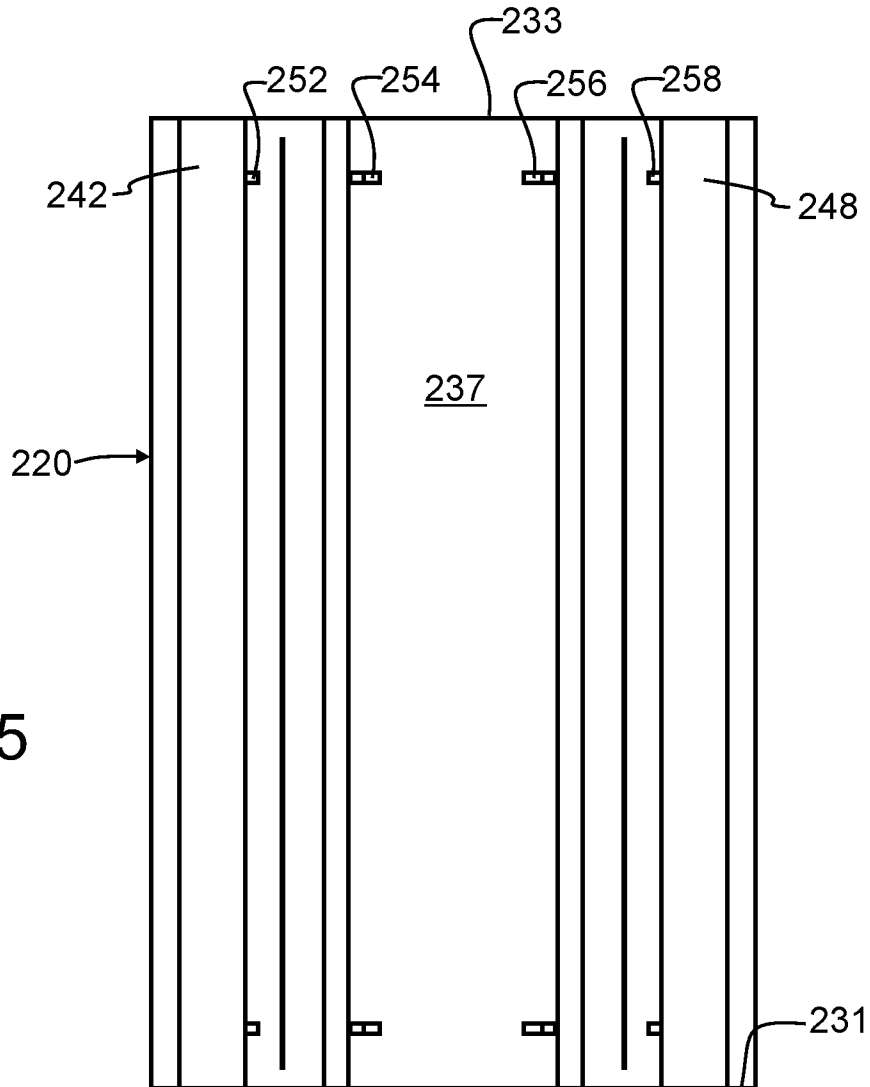

FIG. 5

4/17

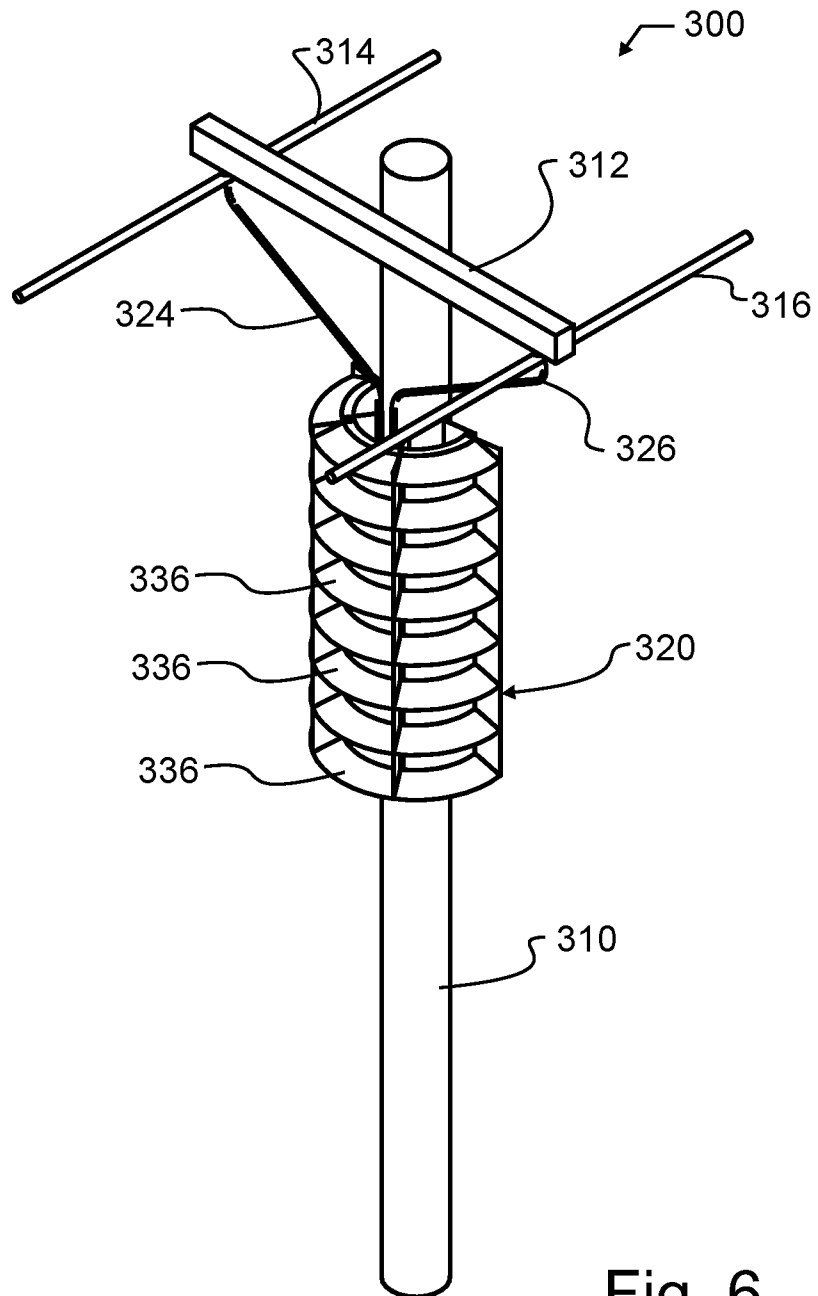

Fig. 6

5/17

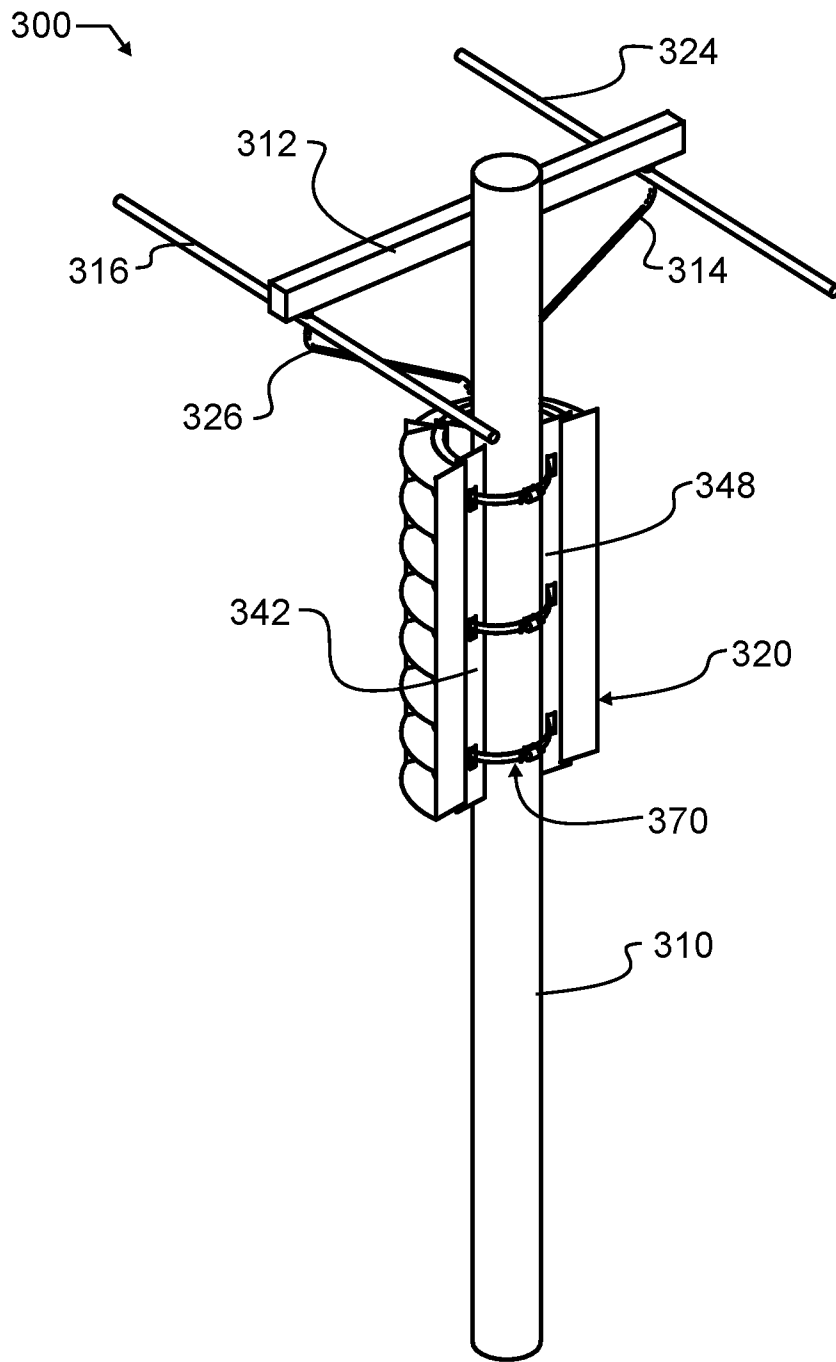

Fig. 7

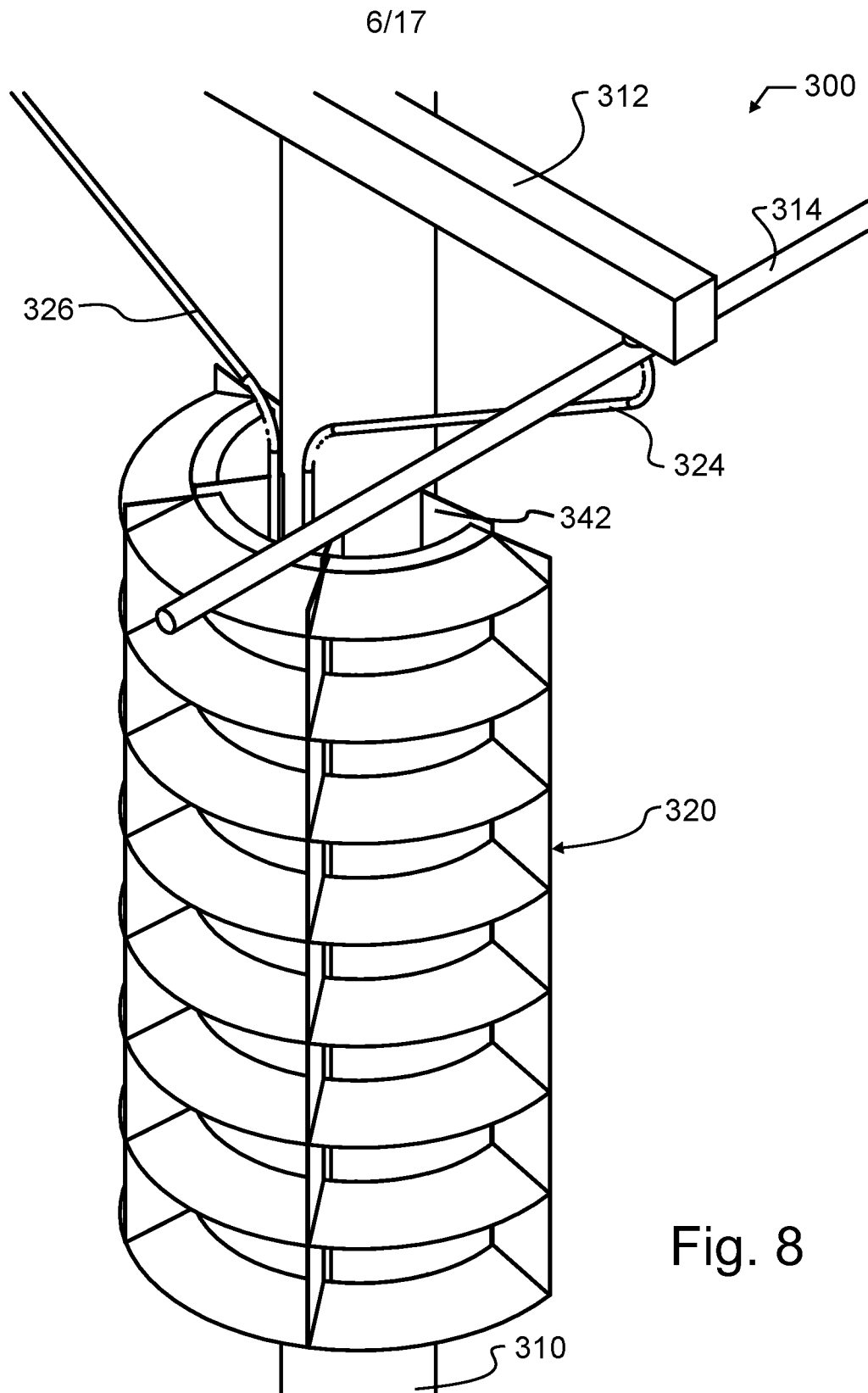

Fig. 8

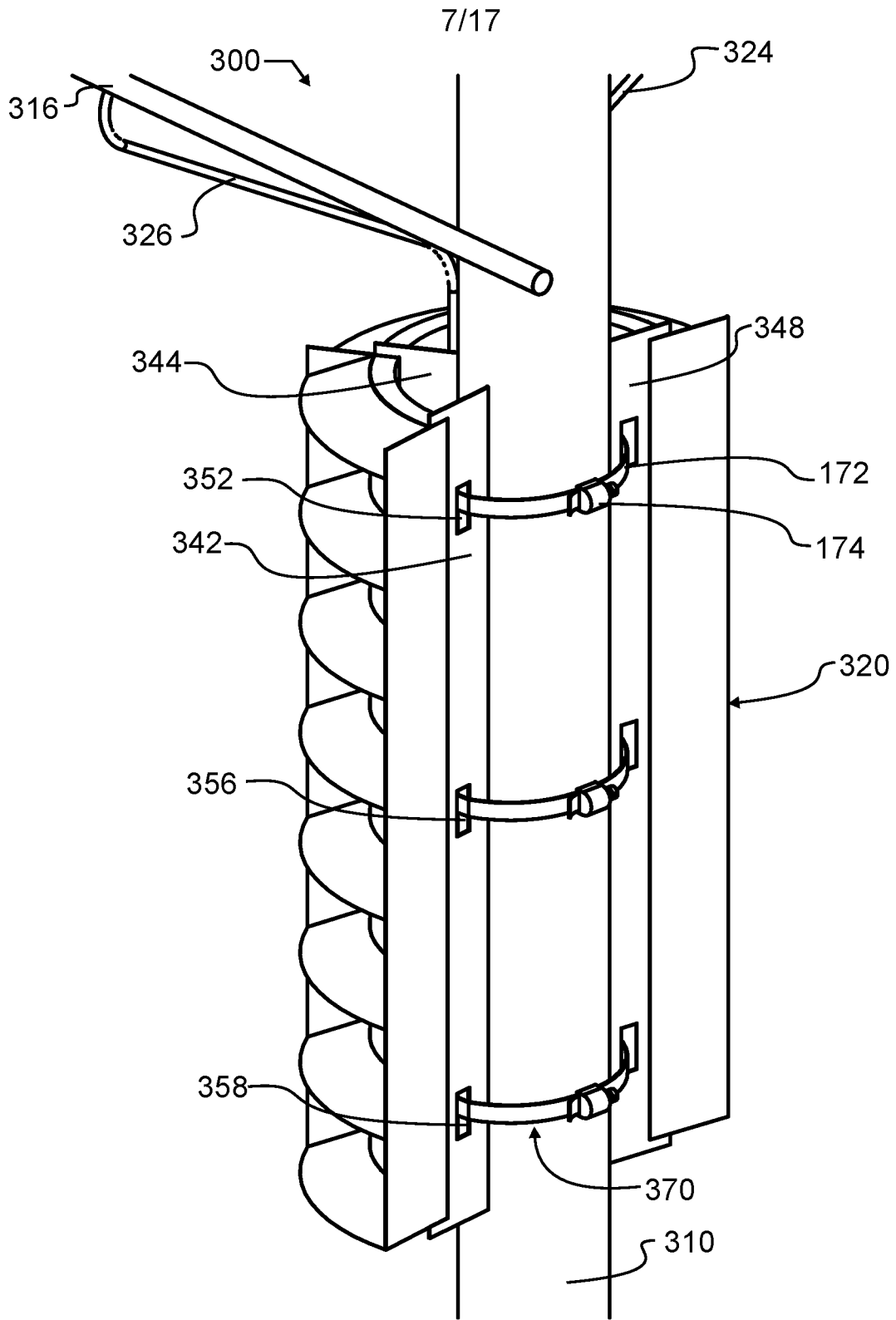

Fig. 9

8/17

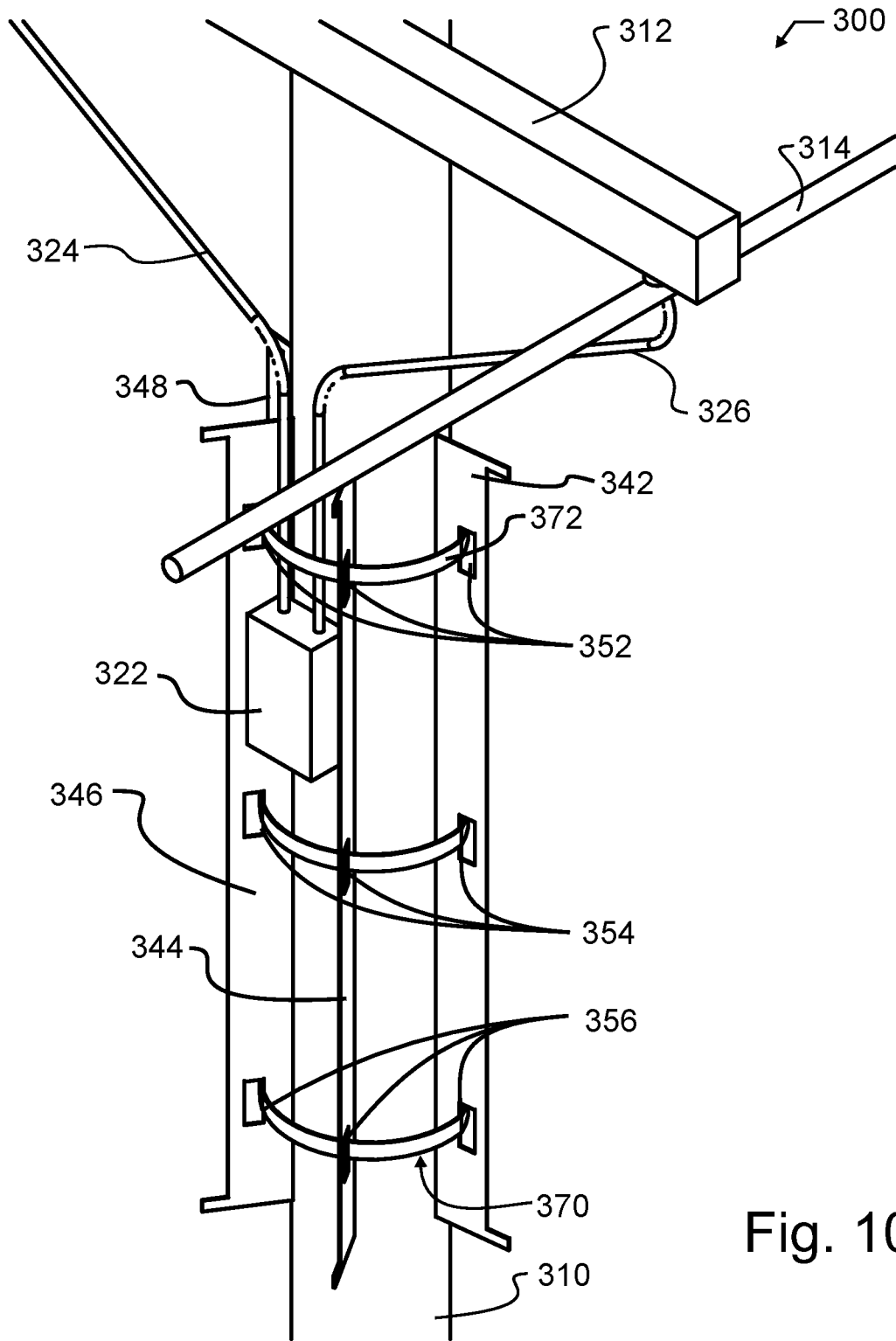

Fig. 10

9/17

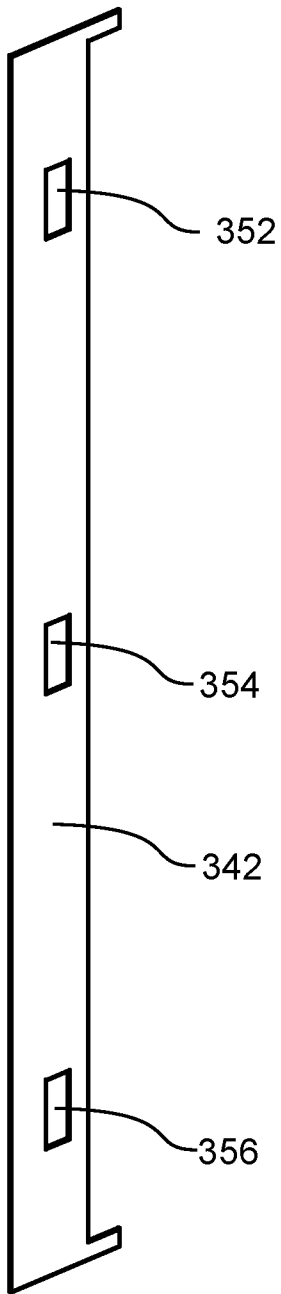

Fig. 11

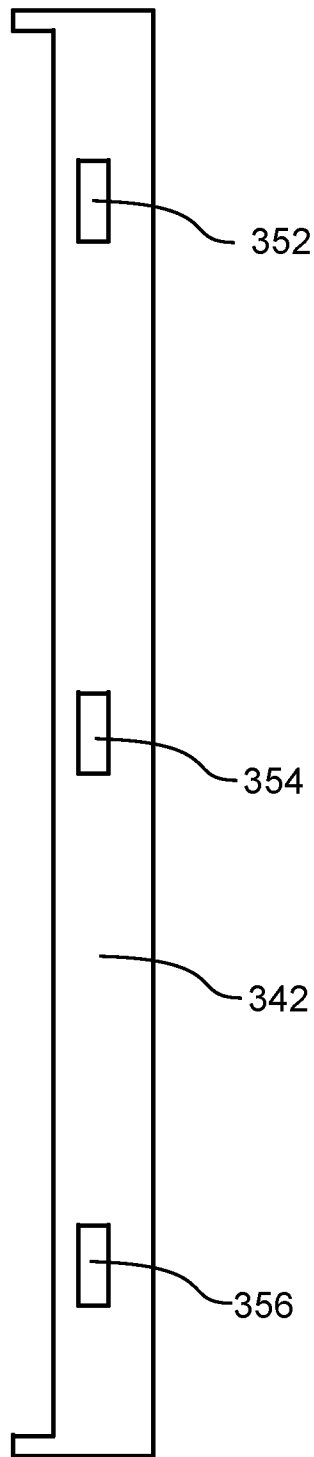

Fig. 12

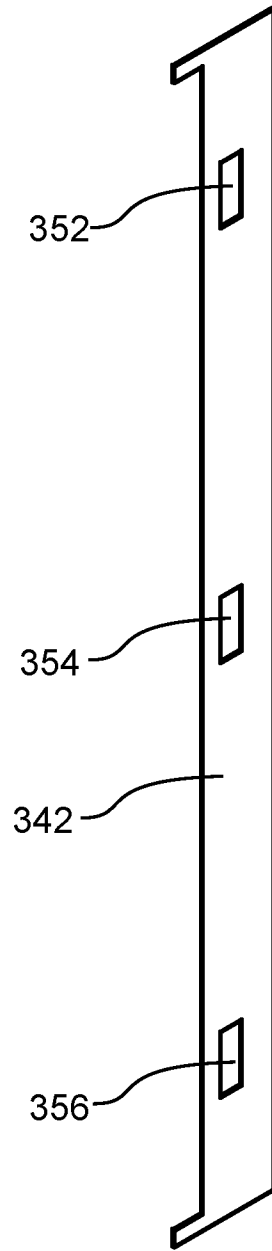

Fig. 13

10/17

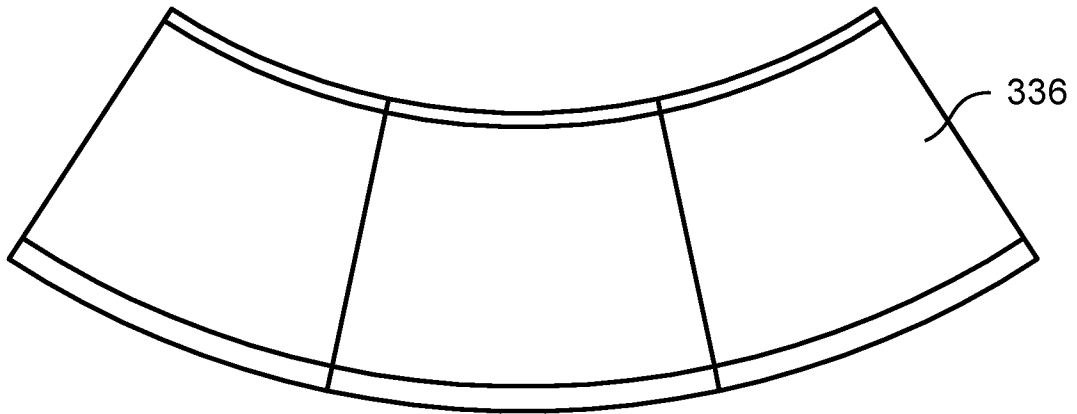

Fig. 14

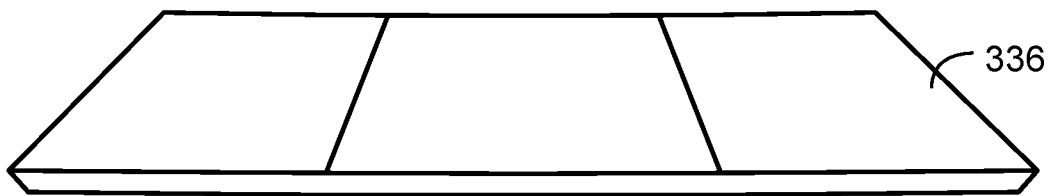

Fig. 15

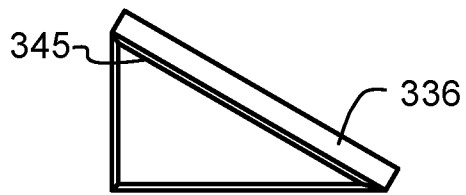

Fig. 16

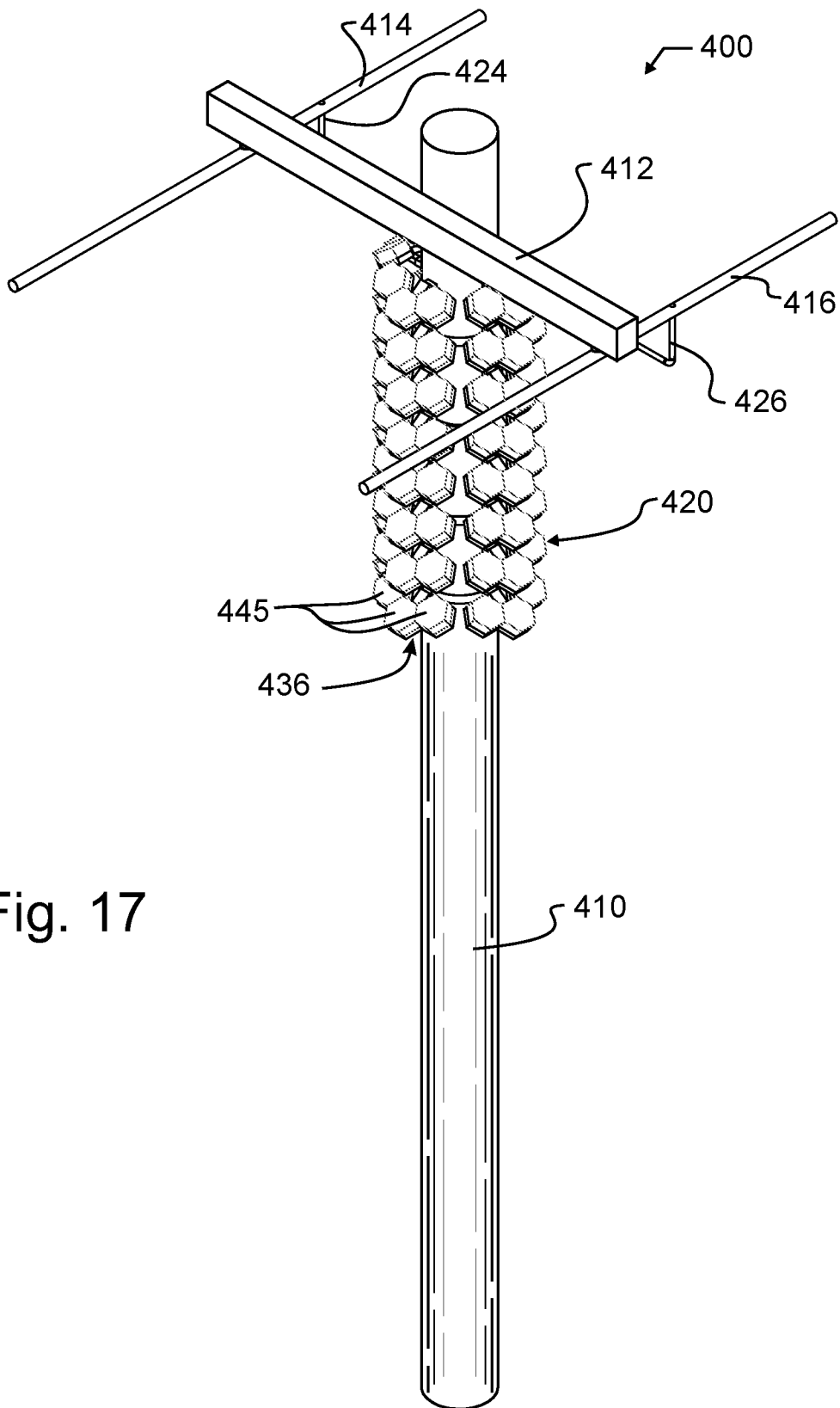

Fig. 17

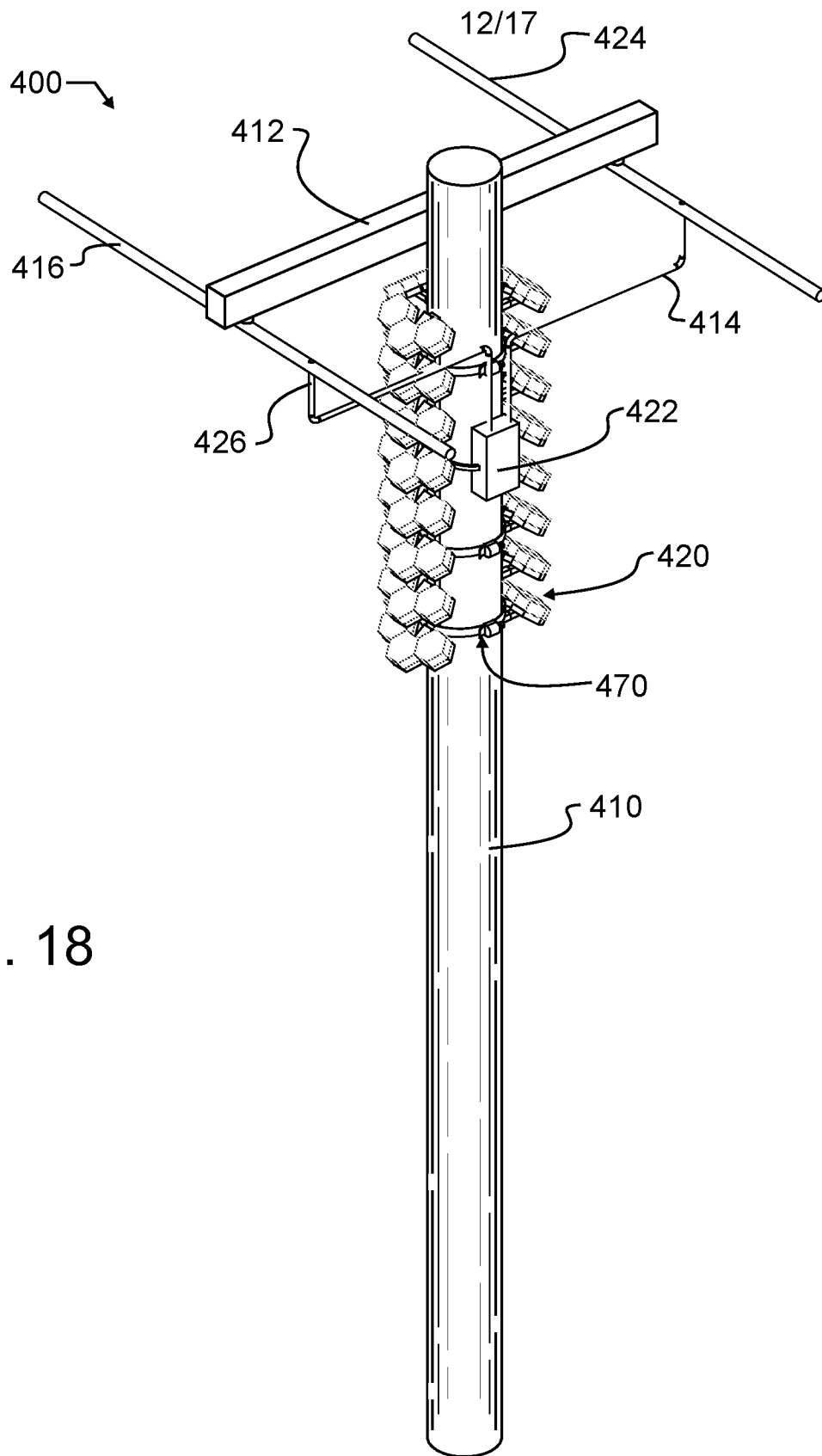

Fig. 18

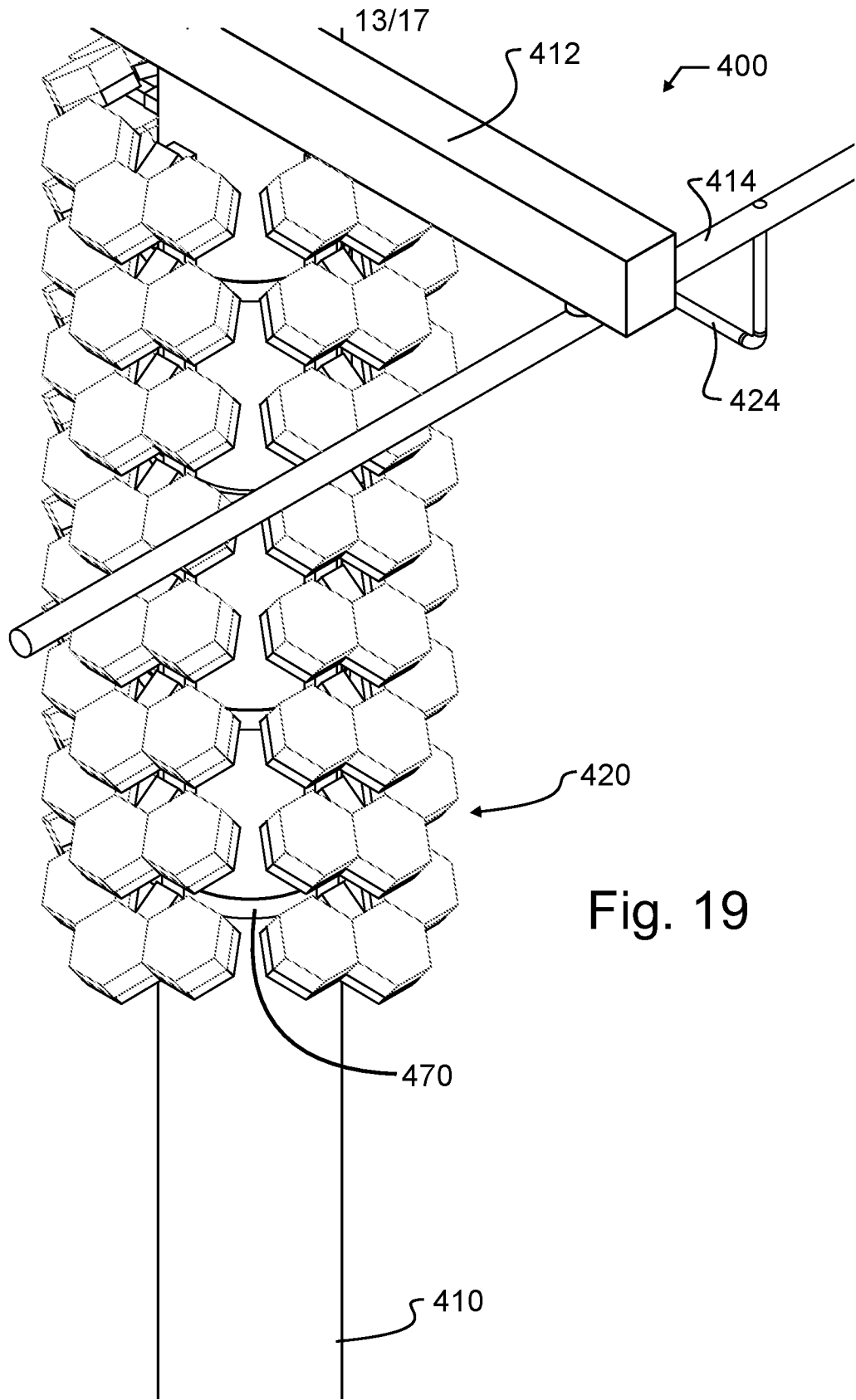

Fig. 19

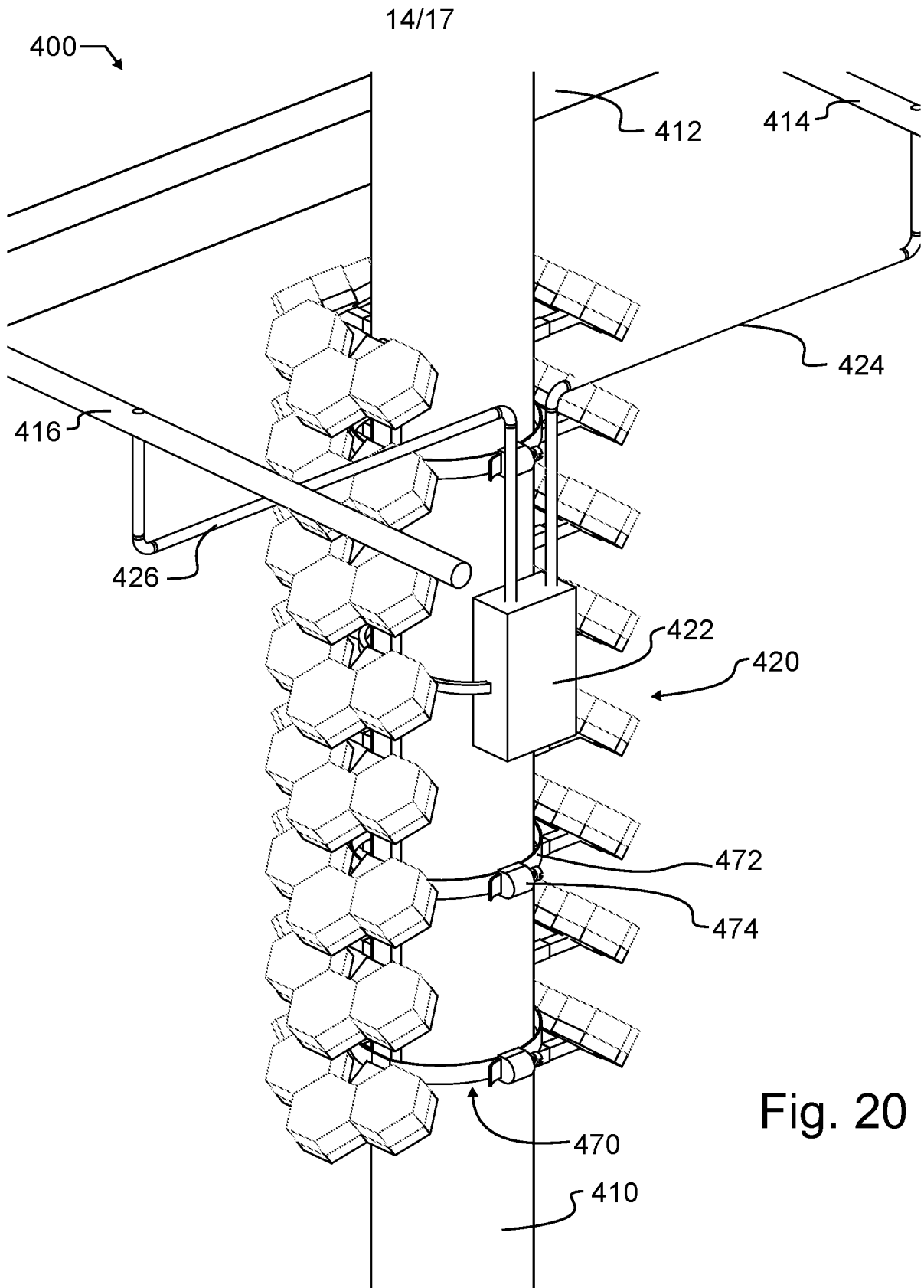
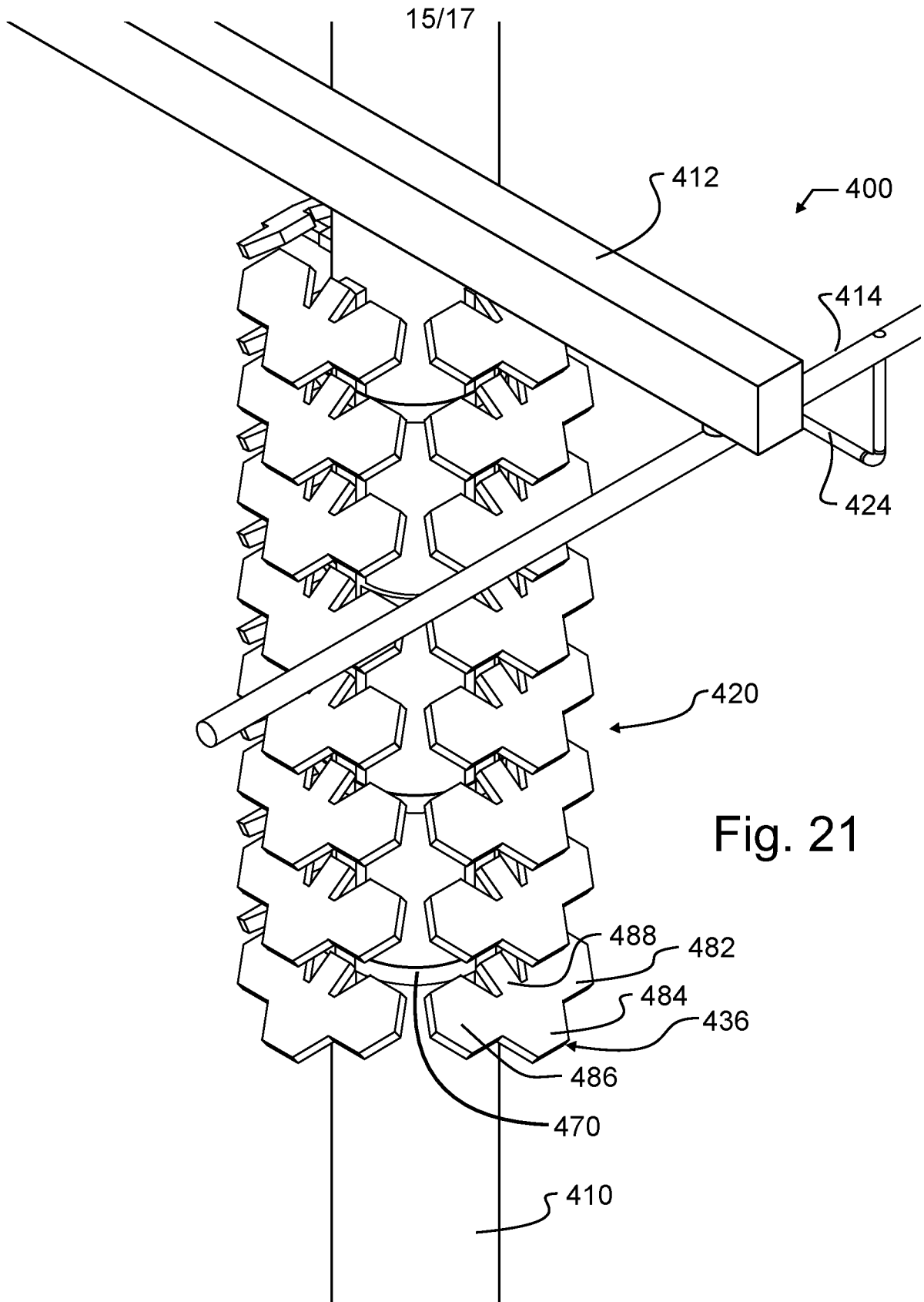

Fig. 20



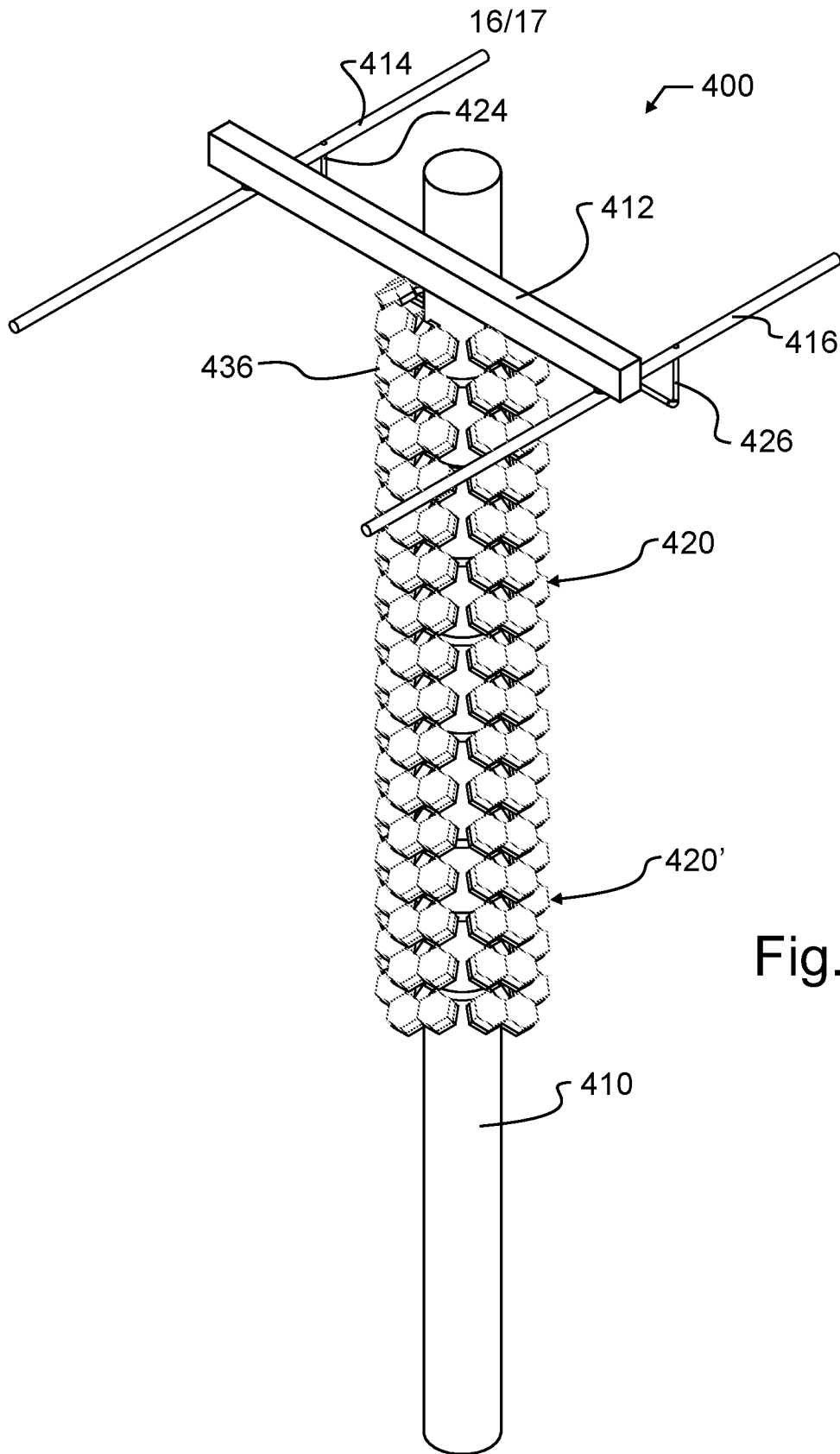

Fig. 22

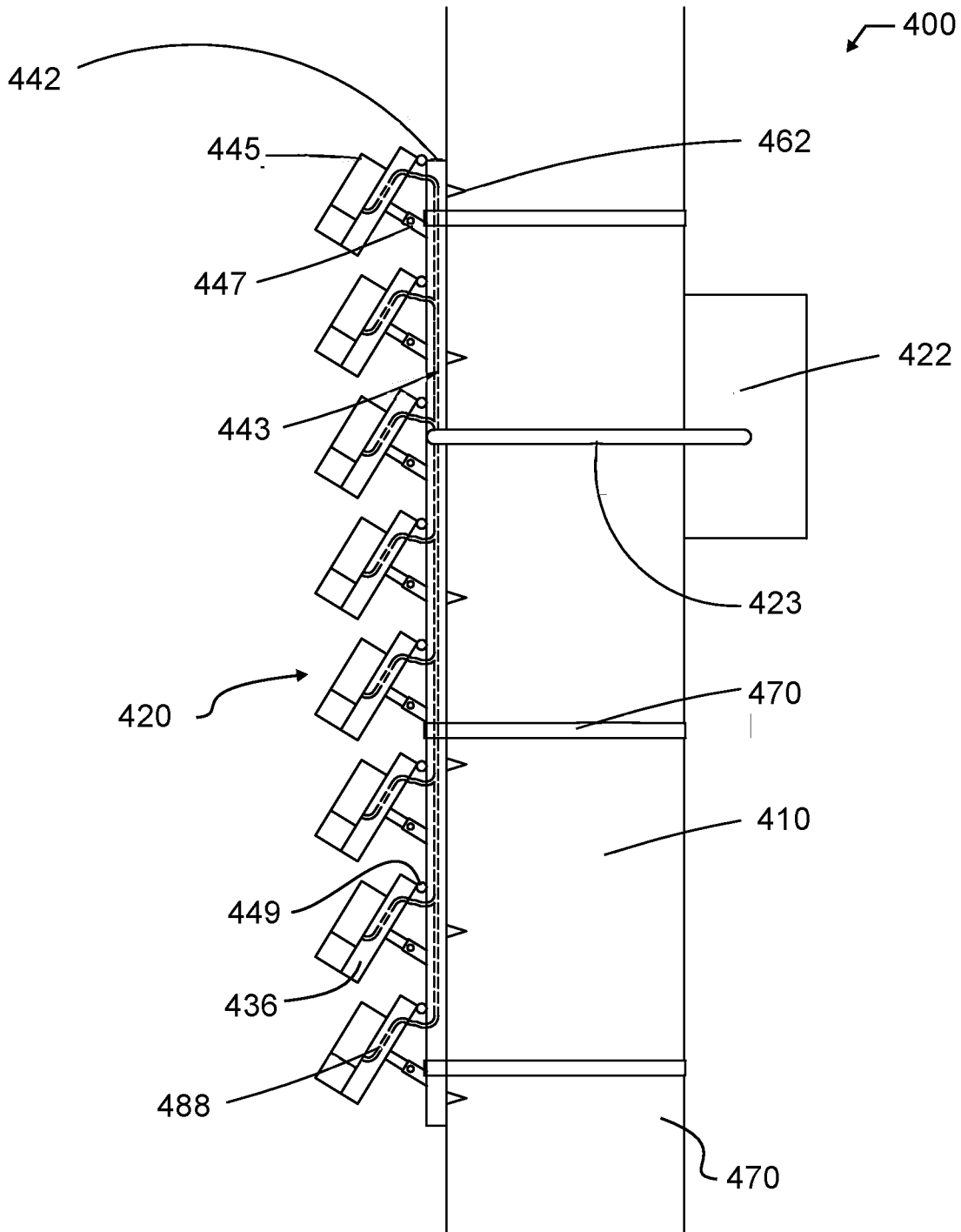

Fig. 23

INTERNATIONAL SEARCH REPORT

International application No.

PCT/US15/42544

A. CLASSIFICATION OF SUBJECT MATTER IPC(8) - H02S 20/20, 20/10, 20/30 (2015.01) CPC - H02S 20/20, 20/10, 20/30 According to International Patent Classification (IPC) or to both national classification and IPC		
B. FIELDS SEARCHED Minimum documentation searched (classification system followed by classification symbols) IPC(8): H02S 20/20, 20/10, 20/30 (2015.01) CPC: H02S 20/20, 20/10, 20/30; Y02E 10/47, 10/563 Documentation searched other than minimum documentation to the extent that such documents are included in the fields searched Electronic data base consulted during the international search (name of data base and, where practicable, search terms used) PatSeer (US, EP, WO, JP, DE, GB, CN, FR, KR, ES, AU, IN, CA, INPADOC Data); Google Patent, Google Scholar, IEEE, EBSCO, ORBIT, Search terms used: solar, panel, photovoltaic, transmission, pole, utility, suspended, cells, east, west, north, south, spacer, guide, rail, inverter, AC/DC, DC/AC, converter, clamp, retain, slide, tooth, teeth, penetrate, pierce, pivot, angle, orientation, tilt		
C. DOCUMENTS CONSIDERED TO BE RELEVANT		
Category*	Citation of document, with indication, where appropriate, of the relevant passages	Relevant to claim No.
Y	US 6,060,658 A (YOSHIDA, H et al.) May 9, 2000; figures 2, 3, 5, column 6, lines 22-29, 30-45, 50-60	1-18
Y	US 2010/0211046 A1 (SMYTH, D et al.) August 23, 2012; figures 1, 2, 4-6, paragraph [0061]	1-18
Y	US 2008/0289153 A1 (BOWATER, B et al.) November 27, 2008; figure 3, paragraphs [0011], [0019]	2, 3
Y	US 2014/0015324 A1 (BRENNAN, M et al.) January 16, 2014; paragraph [0028]	8, 15
Y	US 2014/0276883 A1 (BELAIDI, H et al.) October 24, 2013; figure 5, paragraphs [0027], [0028]	9-15
Y	US 2010/0071684 A1 (COWAN, J et al.) March 25, 2010; figures 1-3, paragraph [0045]	16-18
Y	US 2012/0174478 A1 (CHEN, K et al.) July 12, 2012; paragraphs [0033], [0034]	18
A	US 2008/0137327 A1 (HODULIK, M) June 12, 2008; abstract; figure 4; paragraph [0024], [0029], [0032]	1-18
<input type="checkbox"/> Further documents are listed in the continuation of Box C. <input type="checkbox"/> See patent family annex.		
* Special categories of cited documents: "A" document defining the general state of the art which is not considered to be of particular relevance "E" earlier application or patent but published on or after the international filing date "L" document which may throw doubts on priority claim(s) or which is cited to establish the publication date of another citation or other special reason (as specified) "O" document referring to an oral disclosure, use, exhibition or other means "P" document published prior to the international filing date but later than the priority date claimed "T" later document published after the international filing date or priority date and not in conflict with the application but cited to understand the principle or theory underlying the invention "X" document of particular relevance; the claimed invention cannot be considered novel or cannot be considered to involve an inventive step when the document is taken alone "Y" document of particular relevance; the claimed invention cannot be considered to involve an inventive step when the document is combined with one or more other such documents, such combination being obvious to a person skilled in the art "&" document member of the same patent family		
Date of the actual completion of the international search		Date of mailing of the international search report
04 December 2015 (04.12.2015)		29 DEC 2015
Name and mailing address of the ISA/ Mail Stop PCT, Attn: ISA/US, Commissioner for Patents P.O. Box 1450, Alexandria, Virginia 22313-1450 Facsimile No. 571-273-8300		Authorized officer Shane Thomas PCT Helpdesk: 571-272-4300 PCT OSP: 571-272-7774

INTERNATIONAL SEARCH REPORT

International application No.

PCT/US15/42544

Box No. II Observations where certain claims were found unsearchable (Continuation of item 2 of first sheet)

This international search report has not been established in respect of certain claims under Article 17(2)(a) for the following reasons:

- 1. Claims Nos.:
because they relate to subject matter not required to be searched by this Authority, namely:

- 2. Claims Nos.:
because they relate to parts of the international application that do not comply with the prescribed requirements to such an extent that no meaningful international search can be carried out, specifically:

- 3. Claims Nos.:
because they are dependent claims and are not drafted in accordance with the second and third sentences of Rule 6.4(a).

Box No. III Observations where unity of invention is lacking (Continuation of item 3 of first sheet)

This International Searching Authority found multiple inventions in this international application, as follows:
See supplemental sheet.

- 1. As all required additional search fees were timely paid by the applicant, this international search report covers all searchable claims.
- 2. As all searchable claims could be searched without effort justifying additional fees, this Authority did not invite payment of additional fees.
- 3. As only some of the required additional search fees were timely paid by the applicant, this international search report covers only those claims for which fees were paid, specifically claims Nos.:

- 4. No required additional search fees were timely paid by the applicant. Consequently, this international search report is restricted to the invention first mentioned in the claims; it is covered by claims Nos.:

- Remark on Protest**
- The additional search fees were accompanied by the applicant's protest and, where applicable, the payment of a protest fee.
 - The additional search fees were accompanied by the applicant's protest but the applicable protest fee was not paid within the time limit specified in the invitation.
 - No protest accompanied the payment of additional search fees.

INTERNATIONAL SEARCH REPORT
Information on patent family members

International application No.

PCT/US15/42544

-***-Continued from Box No. III Observations where unity of invention is lacking -***-

The application contains the following inventions or groups of inventions which are not so linked as to form a single general inventive concept under PCT Rule 13.1. In order for all inventions to be examined, the appropriate additional examination fee must be paid.

Group I: Claims 1-15 are directed toward a utility pole suspending transmission lines, at least one solar electric generation station, a plurality of individual solar panels, a power coupling, a plurality of spacer members and a plurality of adjustable brackets.

Group II: Claims 16-18 are directed toward a utility pole suspending transmission lines, at least one solar electric generation station, a plurality of individual solar panels, a power coupling, at least one frame member, a pivot coupling and a slide frame.

The inventions listed as Groups I and II do not relate to a single general inventive concept under PCT Rule 13.1 because, under PCT Rule 13.2, they lack the same or corresponding special technical features.

Group I has at least three separate and distinct solar collector surfaces, defined by at least one generally East facing panel, at least one generally South facing panel, and at least one generally West facing panel, plurality of spacer members, and plurality of adjustable brackets that Group II does not have. Group II has at least one frame member, a pivot coupling, a slide frame, and an angle of orientation that Group I does not have.

The common technical features of Groups I-II are a utility pole suspending transmission lines, at least one solar electric generation station, a plurality of individual solar panels, and a power coupling. The common technical features are disclosed by US 2008/0137327 A1 to Hodulik, M (hereinafter "Hodulik"). Hodulik discloses a utility pole suspending transmission lines (lamp pole connected to grid; abstract; figure 4; paragraph [0024]), at least one solar electric generation station (housing 10 with solar panels; figure 4), a plurality of individual solar panels (three solar panels 16; figure 1, 4), and a power coupling that conducts electricity generated by said at least one solar electric generation station into said transmission lines (grid tied inverter conducts electricity from the housing with solar panels to the grid; figure 9; paragraphs [0029 and 0032]).

Since the common technical features are previously disclosed by the Hodulik reference, these common features are not special and so Groups I-II lack unity.