

C. E. BAUER.
 BRAKE BEAM FINGER GUARD.
 APPLICATION FILED JUNE 5, 1909.

953,314.

Patented Mar. 29, 1910.

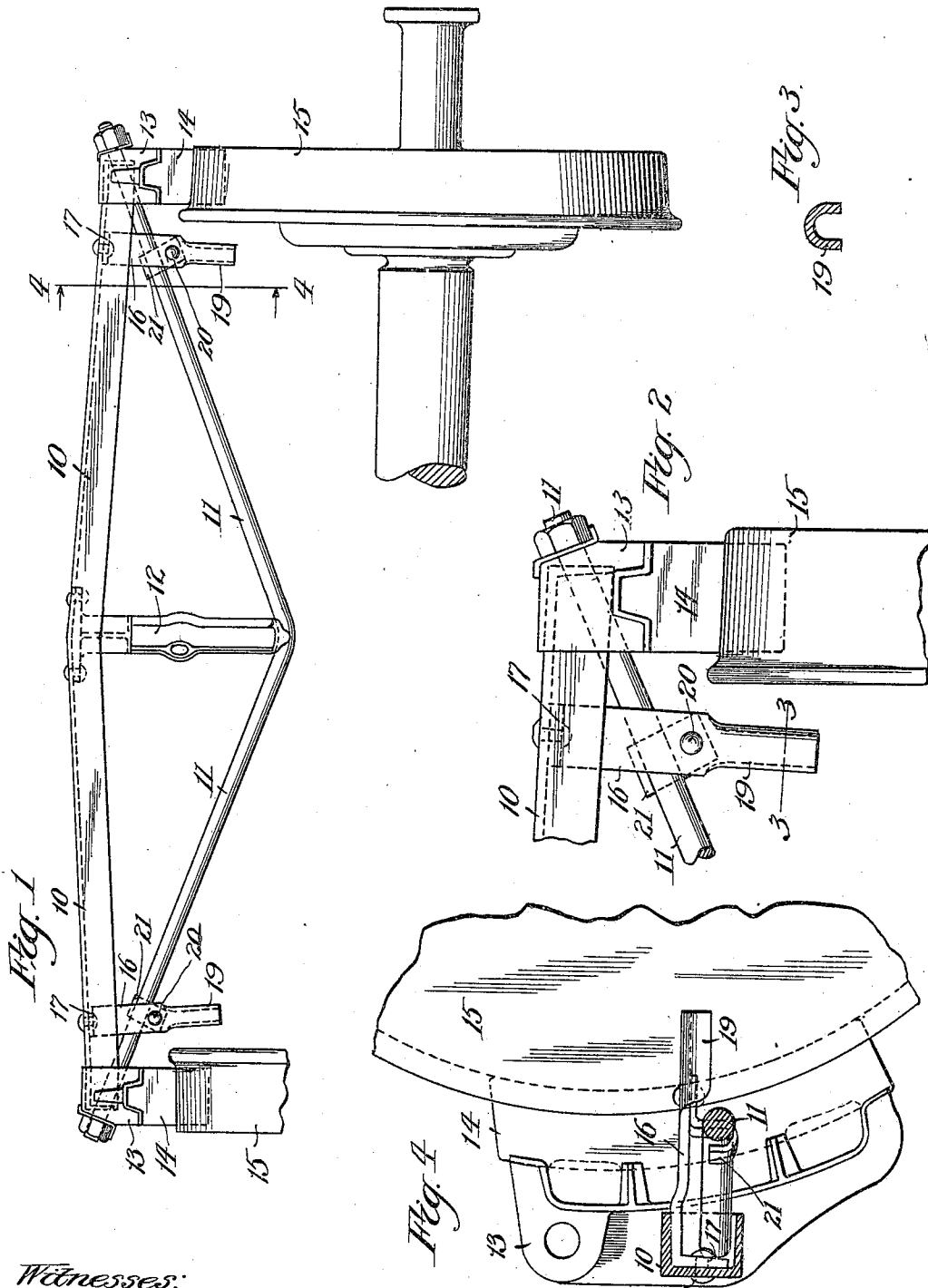

Witnesses:
 Clara L. Rossmore.
 E. Molitor

Inventor:
 by Carl E. Bauer
 Luthicum Belt & Fuller
 Atty's.

UNITED STATES PATENT OFFICE.

CARL E. BAUER, OF HAMMOND, INDIANA, ASSIGNOR TO SIMPLEX RAILWAY APPLI-
ANCE COMPANY, OF CHICAGO, ILLINOIS, A CORPORATION OF ILLINOIS.

BRAKE-BEAM FINGER-GUARD.

953,314.

Specification of Letters Patent. Patented Mar. 29, 1910.

Application filed June 5, 1909. Serial No. 500,378.

To all whom it may concern:

Be it known that I, CARL E. BAUER, a citizen of the United States, residing at Hammond, in the county of Lake and State of Indiana, have invented certain new and useful Improvements in Brake-Beam Finger-Guards, of which the following is a specification.

My invention concerns improvements in finger guards for railway car brake beams, its main objects and purposes being the provision of a device of this character which can be manufactured at small cost, which will not require casting, and which can be readily and easily secured to the parts of the brake-beam.

In the preferred embodiment of the invention a flat bar is bent and manipulated in such a manner as to afford an attachment portion or ear for securing to the compression part of the brake-beam and to provide a curved or convex part adjacent to the car wheel, the bar being bent transversely to effect the shape and conformation of this latter part. To assist in maintaining such finger in place I rivet or otherwise secure thereto a hook-shaped strap adapted to engage and cooperate with the tension bar of the brake-beam. It will be apparent, therefore, that a desirable embodiment of the invention comprises only two metal parts secured together, which may be readily and economically manufactured from sheet or bar metal.

In the accompanying drawing I have illustrated the preferred embodiment referred to, like reference characters referring to the same parts through the various views.

In the drawing—Figure 1 is a plan view of a brake-beam and portions of the car-wheels, the former being equipped and supplied with the finger guards; Fig. 2 is an enlarged plan view of the end portion of the brake-beam shown in Fig. 1; Fig. 3 is a cross-section on line 3—3 of Fig. 2; and Fig. 4 is a vertical section on line 4—4 of Fig. 1, the parts being viewed in the direction indicated by the arrows.

The brake-beam to which the finger guards are applied includes the usual cambered channel compression bar 10 and the cooperating round tension rod 11 secured to the compression bar at its ends, the usual strut and fulcrum post 12 being interposed between the two parts, as is customary. To

the ends of this brake-beam the ordinary brake heads 13, 13 and attached shoes 14 are applied for cooperation with the treads of the car wheels 15.

In order to prevent undue lateral displacement or swinging of the brake-beam and shoes, a pair of finger guards for cooperation with the wheels are employed, each of such guards comprising a main bar 16 having its inner end 17 bent downwardly and riveted at 18 against the inner face of the channel compression bar 10, the top surface of such bar resting against the bottom face of the top flange of the channel bar, whereby turning or rotation of the bar on the rivet is effectively prevented. As is clearly indicated, the other end of such bar is in proximity to one of the car wheels with which it is adapted to cooperate to prevent undue lateral displacement of the brake beam, and in order that such finger guard may present to the wheel a smooth curved surface when contact between the two takes place, such end 19 of the bar is bent into substantial semi-cylindrical shape, as indicated in Fig. 3, this portion of the bar being broader than the main body thereof before such bending or pressing. To assist in maintaining the finger guard in place I rivet thereto at 20 a short hook-shaped or bar 21 which takes around the under side of the adjacent tension rod 11, such hook holding the curved portion of the guard in proper relation to the wheel.

To those skilled in this art it will be apparent that the construction herein described and illustrated in the drawing is of simple structure and economical to manufacture, such guard being also readily and easily applied to the brake beam. The manner of fastening the same to the beam is particularly firm and rigid even though only a single pair of rivets are employed; consequently displacement of the guard relative to the beam is prevented, and the former is at all times presented in proper relation to the car wheel to effect the function for which it is employed. Owing to the fact that the surface of the guard, which may at intervals contact with the revolving wheel, is smooth and of curved formation, the engagement of the guard with the wheel results in an easy and smooth contact which limits the displacement of the brake beam and maintains the brake shoes at all times in

proper position for engagement with the wheels.

It is to be understood and will be readily appreciated by those skilled in the art that the invention herein set forth is not limited and restricted to the precise structural features shown and described, since minor mechanical changes may be made without departure from the essence of the invention and without the loss of any substantial benefits and advantages.

I claim:

1. A finger-guard for brake-beams having a flat bar bent transversely at that portion likely to contact with the car wheel to present a convex exterior surface to the wheel, substantially as described.

2. A finger-guard for brake-beams having a flat bar bent transversely at that portion likely to contact with the car wheel to present a convex exterior surface to the wheel, the other end of such bar being bent laterally and adapted to be fastened to the compression member of the brake-beam, substantially as described.

3. A finger guard for brake beams comprising a shank having an angular terminal shaped to fit a brake beam, the other end of the shank being convexed transversely, and a tension rod engaging brace member depending from the shank.

4. A finger-guard for brake-beams having a flat bar bent transversely at that portion likely to contact with the car-wheel to present a convex exterior surface to the wheel, the other end of such bar being bent laterally and being adapted to be fastened to the compression member of the brake-beam, such finger-guard also having a hook fastened thereto and adapted to engage and cooperate with the tension rod of the brake-beam, substantially as described.

5. The combination of a brake-beam having a channel compression member and a cooperating tension rod, and a finger guard comprising a flat bar bent transversely at one end to present a convex exterior surface adjacent to and adapted to cooperate with the car wheel, said finger-guard bar lying against the inner face of one of the compres-

sion bar flanges, one end of said finger-guard bar being bent laterally and riveted to the inner face of the web of said channel bar, such finger-guard also including a hook-shaped retaining member formed from a flat bar, one part thereof being riveted to the finger-guard proper, the hook-shaped portion thereof engaging the tension rod and assisting in maintaining the finger-guard in proper position, substantially as described.

6. The combination with a brake beam and a cooperating tension rod, of a finger guard carried by the brake beam and extending across the tension rod out of contact therewith, and a brace member carried by the finger guard and engaging the tension rod, substantially as described.

7. The combination with a brake beam and a cooperating tension rod, of a finger guard carried by the brake beam and extending across the top of the tension rod out of contact therewith, and a brace member depending from the finger guard and engaging the tension rod, substantially as described.

8. The combination with a brake beam and a cooperating tension rod, of a finger guard riveted to the brake beam, and a brace member depending from the finger guard and engaging the tension rod, substantially as described.

9. The combination with a brake beam and a cooperating tension rod, of a finger guard carried by the brake beam, and provided with a brace member connected to the finger guard in front of the tension rod and having a hooked terminal embracing said rod, substantially as described.

10. A finger guard for brake beams having one end portion transversely convex for engagement with a car wheel, and provided with a tension rod engaging member depending from the finger guard and extending toward the attaching end of the finger guard, substantially as described.

CARL E. BAUER.

Witnesses:

W. H. CAMERON,
GEO. C. MURRAY.