

(No Model.)

2 Sheets—Sheet 1.

J. W. JAMES.
MOWING MACHINE.

No. 441,069.

Patented Nov. 18, 1890.

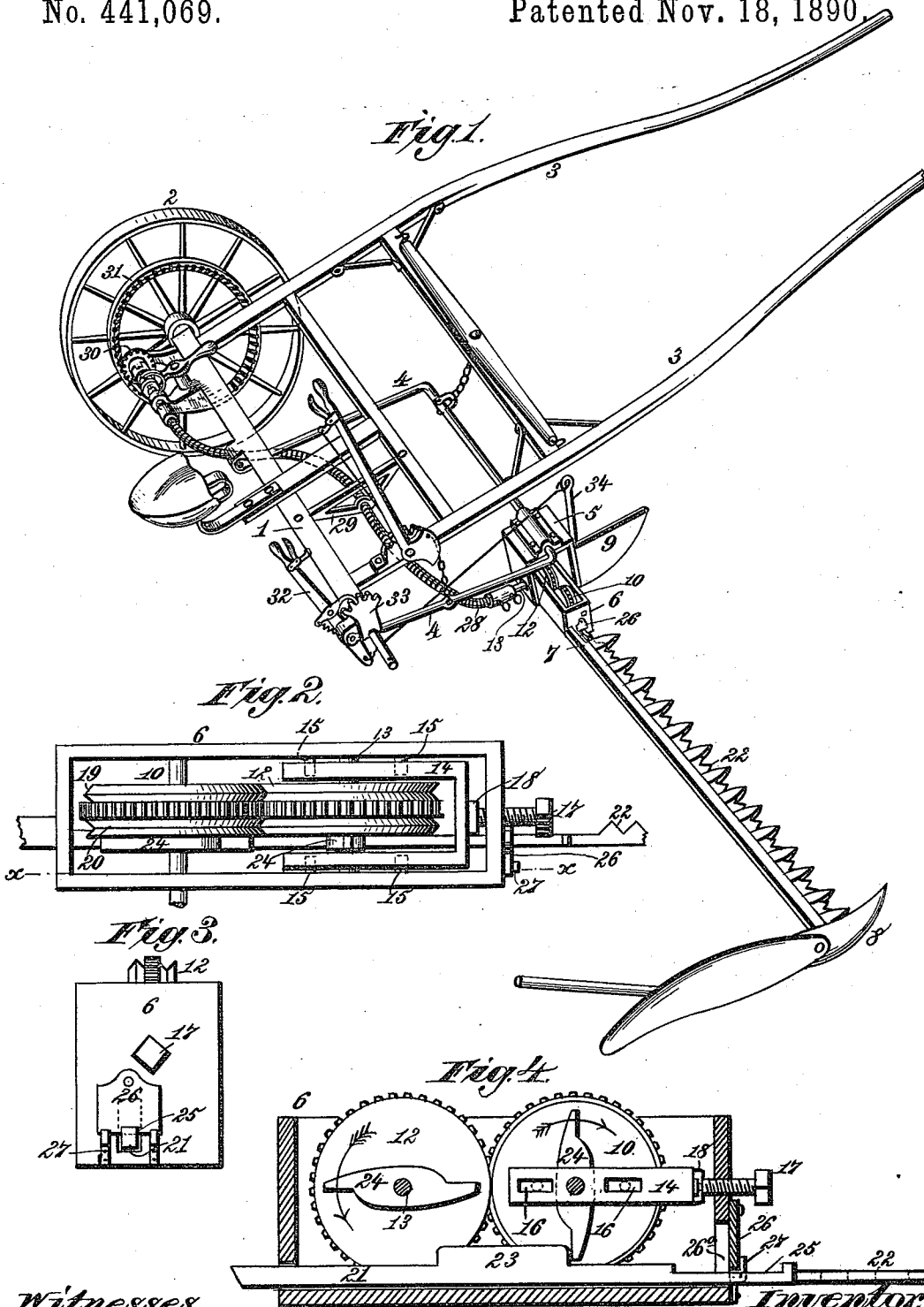

Witnesses,
Robert G. Wright,
J. A. Kutherford

Inventor:
Jack W. James,
 By *James L. Norris,*
Atty.

(No Model.)

2 Sheets—Sheet 2.

J. W. JAMES.
MOWING MACHINE.

No. 441,069.

Patented Nov. 18, 1890.

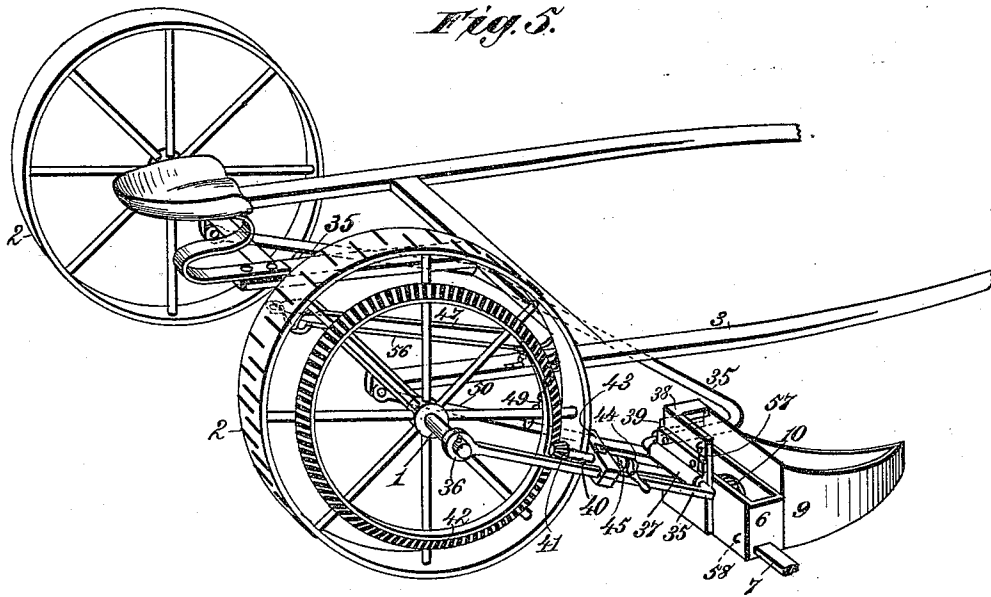

Fig. 6.

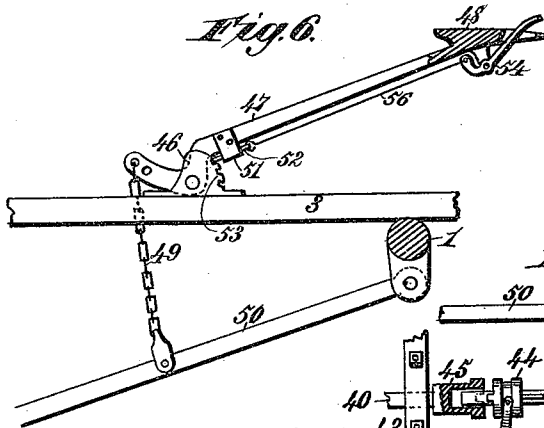

Fig. 7.

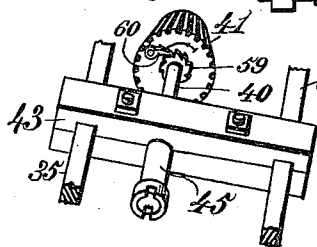
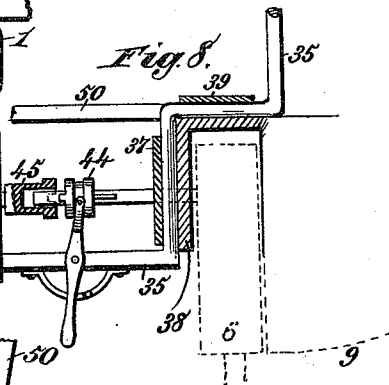

Fig. 8.



Witnesses.

Robert G. G. G.
J. A. Rutherford.

Inventor.

Jack W. James.
By James L. Norris.
Atty.

UNITED STATES PATENT OFFICE.

JACK W. JAMES, OF CUBA, TENNESSEE.

MOWING-MACHINE.

SPECIFICATION forming part of Letters Patent No. 441,069, dated November 18, 1890.

Application filed January 23, 1890. Serial No. 337,831. (No model.)

To all whom it may concern:

Be it known that I, JACK W. JAMES, a citizen of the United States, residing at Cuba, in the county of Shelby and State of Tennessee, have invented new and useful Improvements in Mowing-Machines, of which the following is a specification.

My invention relates to mechanism for operating the cutter-bars of mowing-machines, and the purpose thereof is to provide simple means for reciprocating the knives without employing a pitman driven in the manner usually employed in this class of mechanism.

It is well known that in operating-mowers the reciprocation of the cutter-bar is frequently brought to a sudden stop, and upon examining the cause thereof it is found that there is a clogging of the cutter-bar, or of the wrist which drives it, with grass, or else a solid matter of some kind is jammed between the movable and stationary knives. In almost every case it is found that the cutter-bar is arrested when the actuating-pitman is upon a dead-center, and it is well understood that a slight obstruction may arrest the movement of the knives provided it acts thereon at the moment when the wrist is upon one of the dead-points.

It is the purpose of my invention to provide means for driving the cutter-bar, whereby the use of a pitman and its operating-wrist shall be wholly avoided, and whereby, therefore, no dead-centers or dead-points shall be encountered in the operation of the mechanism.

It is my further purpose to convey the power for reciprocating the cutter-bar directly from the traction-wheels, and to so far diminish the friction and resistance and apply such power at so great an advantage that an ordinary mower may be drawn and operated by a single horse, instead of a pair, as has been considered necessary heretofore.

The invention consists in the several novel features of construction and new combinations of parts hereinafter fully set forth, and then definitely pointed out in the claims following this specification.

To enable others skilled in the art to practice my said invention, I will now describe the same in detail, reference being had to the accompanying drawings, in which—

Figure 1 is a perspective view of a mowing-machine in which my invention is embodied. Fig. 2 is a plan view of the cutter-head, showing the gearing for reciprocating the cutter-bar. Fig. 3 is an end elevation of the cutter-head. Fig. 4 is a longitudinal section of the same upon the line *x x*, Fig. 2. Fig. 5 is a perspective view of a mower, showing a modified construction. Fig. 6 is a detail sectional view taken transversely to the axle, showing the foot-lever lift for the cutter-bar with its locking-pawl. Fig. 7 is a detail perspective of the pinion-transmitting power from the main driving-wheel to the cutter-bar with its support, and Fig. 8 is a detail horizontal sectional view through the sleeves which rigidly attach the cutter-box supporting-bracket to the swinging frame.

In the said drawings, the reference-numeral 1 designates the axle of the mower, upon which are mounted traction-wheels 2, one of which is removed in the drawings to exhibit the working parts.

The thills 3 are attached by any suitable means to the axle, and to the latter are pivoted the rear extremities of a yoke-frame 4, comprising a horizontal front bar arranged transverse to the draft-line, and on which is loosely hung or hinged by suitable clips or other devices a cutter-head 5, carrying a shoe 9, and composed of a hollow box-like frame open at its bottom, and in which is arranged a rectilinear cutter-box 6, located substantially parallel with the axle and comprising a flat bottom wall and vertical front, rear, and end walls. The end walls of this box are provided with aligned slots or openings, as shown in Fig. 4, for the passage of a bar forming part of the cutter-bar, hereinafter explained. The finger-bar 7 carries a shoe 8, and is rigidly attached to and projects from the cutter-box, and within the latter is journaled a gear 10, which receives motion from a similar gear 12, having its shaft journaled in a yoke 14, arranged within the box 6 and supported by studs 15, which project from the inner walls of the box and lie within slots 16, formed in the parallel arms of the yoke. A set-screw 17 is provided for adjusting the yoke, and this screw has a screw-threaded engagement with the cutter-box.

The inner end of the screw is swiveled to a boss 18 on the yoke, and the construction is such that by rotating the screw the yoke may be adjusted to force the teeth of the gear 12 into engagement with the gear 10. Upon each of these gears is formed a lateral disk, having a frictional wedging periphery 19, which makes engagement with an opposite correspondingly-shaped channel 20, formed in a lateral disk on the intermeshing gear. These friction-surfaces are so formed that when the teeth of the gears 10 and 12 are meshed there will be a proper frictional contact between the friction edge and channel on one of the corresponding parts upon the other gear.

Arranged in the lower part of the box or frame 6 is a bar 21, which at its ends projects through openings in the end walls of the box, one extremity of said bar being attached to the end of the sickle-bar or cutter-bar 22. Upon this bar is formed a lug 23, and upon the axes of the two gears 10 and 12 are arranged cam-bars 24, which engage alternately with said lug 23 and throw the bar in opposite directions. The reciprocating movement thus produced is limited or gaged by means of a notch 25, in which lies the end of a keeper or latch-plate 26, pivoted upon the inner end of the box 6. The end of this latch-plate lies within detents 27, fastened to the end of the box. By swinging this latch-plate to one side the bar may be withdrawn, an opening 26^a being formed in the end of the box 6 for that purpose.

Rotation is communicated to the shaft of the driving-gear 12 by means of a flexible shaft 28, supported in a suitable bracket 29 on the axle and frame of the mower and provided at its end with a gear 30, meshing with an internally-toothed gear 31 on one of the traction-wheels. I may, however, use any other motive power adapted to the purpose. The fronts or points of the knives on the knife-bar are raised and lowered by a lever 32, fulcrumed upon a bracket 33 on the axle 1, and connected by a rod, wire, or cord with a bar 34 on the cutter-head.

The present invention is in some features an improvement upon that for which an application for Letters Patent was filed by me the 25th day of July, 1889, Serial No. 318,611, and allowed the 7th day of September, 1889.

I may substitute for the organization shown and described that shown in Figs. 5 to 7, both inclusive. In this construction the cutter-box 6 and shoe 9 are supported by a metallic frame 35, which is composed of a continuous bar either round or square. One end of this bar, is provided with a loop or eye 36, having bearing on the prolonged end of the axle and extending forward and downward to the box 6, where it is bent at right angles and passes through a sleeve 37, bolted to a bracket-support 38, on which the cutter-box 6 is pivotally mounted. The bar is then bent forward, passing around the corner of the bracket, on the

end of which is a sleeve 39, similar to 37, through which the bar passes, so that the two sleeves serve to rigidly connect the supporting-bracket to the swinging frame or bar 35, which latter is also bent into substantial parallelism with the axle and then at right angles to itself, its other end being mounted on a pivot-pin carried by a bracket hanging from the axle. Within the box 6 are arranged the gears 10 and 12, by which the cutter-bar is reciprocated. The gear driven from the main wheel is carried by a shaft 40, arranged outside the main driving-wheel and having a bevel-pinion 41, which meshes with a gear-annulus 42 on the wheel. This shaft is supported by a frame 43, (shown in Fig. 7,) and consisting of blocks bolted upon the square bar 35 and a lift-bar 50, and having a bearing for the shaft. A common and well-known form of clutch 44 is splined on the shaft in any ordinary manner and engages a clutch-box 45, whereby the cutter-bar may be rendered inoperative at will. The supporting-bracket 38 carries the shoe 9, and is so constructed or open at the top and bottom that the cutter-box 6 can turn on the shaft 40 as a pivot or center, and therefore the cutter and finger-bars can be turned to an approximately perpendicular position.

Upon one of the thills is mounted a bracket-frame 46, within which is fulcrumed a lever 47, which extends rearwardly and is provided with a foot-piece 48. The end of said lever is extended beyond its fulcrum and connected by a chain 49 to a lift-bar 50, pivotally attached at one end beneath the axle and at the other end bolted to the bracket 38. Sliding in a guide 51 upon the lever is a locking-pawl 52, which engages teeth 53, formed in the curved edges of the bracket-frame 46. This pawl is operated by a bell-crank lever 54, pivoted beneath the foot-piece 48, and having its end rising above the surface of the latter. To the upwardly-turned short arm of this lever is connected a wire or link rod 56, which operates the pawl. Upon the upper right corner of the bracket 38 is a hasp 57, which engages a staple 58 on the cutter-box when the latter is turned upon its shaft 40, as on a pivot-bolt, to raise it to a vertical or nearly vertical position.

By placing the bevel-pinion 41 outside the driving-wheel the tendency of the machine to turn in a circle will be effectually obviated. To operate the lift in order to raise the cutter, the driver places his foot upon the foot-piece 48, pressing upon the rising point of the lever 54, whereby the pawl is withdrawn from its teeth. The pressure of the foot and weight of the body then raises the cutter-bar, whereupon the heel is raised and the pawl immediately locks by the use of any suitable form of spring, throwing it into mesh with its teeth. A ratchet 59 is mounted on the shaft 40, and a spring-pawl 60 on the bevel-pinion 41 gives reciprocation as the machine moves forward, but allows the pinion, which is loose on the end of the shaft to turn without im-

parting movement when the machine is backed.

In the construction shown by Fig. 1 it is possible to so relatively arrange the parts that the cutter-box 6 could turn on the shaft 13, which extends through the cutter-head 5, and connects with the flexible driving-shaft 28, and if this be the case suitable means—such as described with reference to Fig. 5—will be provided to hold the cutter and finger bars when turned to an approximately perpendicular position.

What I claim is—

1. The combination, in a mowing-machine, of a cutter-head or bracket, a cutter-box journaled beside the cutter-head or bracket and adapted to swing in a vertical plane, a finger-bar attached to the cutter-box, a cutter-bar having an extension located in the cutter-box and provided with a lug, and two intermeshing rotary gears arranged in the swinging cutter-box and having cams to actuate the cutter-bar, substantially as described.

2. In a mowing-machine, the combination with the cutter-head, of a pair of gears journaled therein, each gear carrying a cam-bar, an adjustable yoke within which one of said gears is mounted, a bar having a lug upon which the cam-bars act alternately, and means for adjusting the yoke to mesh the gears, substantially as described.

3. In a mowing-machine, the combination, with the cutter-head, of two gears having intermeshing teeth and each provided with lateral disks, one having a wedging frictional periphery and the other a correspondingly-shaped channel engaging, respectively, a channel and a friction periphery on the other gear, cam-bars carried by said gears, a bar attached to the cutter-bar and having a lug acted upon by said cam-bars alternately, a yoke giving journal-support to one of the gears and supported by a stud projecting from the cutter-head and lying in slots in said yoke, and a set-screw adjusting said yoke, substantially as described.

4. In a mowing-machine, the combination, with the cutter-head having a box or frame mounted thereon, of two gears journaled in said box, a bar attached to the cutter-bar and provided with a lug, which is acted upon alternately by cam-bars carried by the gears, said bar projecting at its ends through openings in the box, and a latch-plate pivoted on

the end of the box and covering one of said openings, its end lying in a notch in said bar and limiting the movement thereof, the end of the latch lying in detents fastened to the box, substantially as described.

5. In a mowing-machine, the combination with the cutter-head having a frame or box, of a gear journaled therein on a fixed axis, an intermeshing gear journaled in a yoke adjustably supported in said box, said gears having alternately-opposite friction peripheries engaging correspondingly-formed channels, a set-screw to adjust the yoke, a bar having its ends projecting from openings in the box and provided with a lug acted upon alternately by cam-bars driven by said gears, a cutter-bar attached at one end of said bar, and a latch-plate pivoted on the end of the box and covering one of said openings, the end of the latch-plate lying in a notch in the bar limiting its reciprocation, and supported by detents mounted in the end of the box, substantially as described.

6. In a mowing-machine, the combination of the cutter-box, of a frame composed of a metallic bar having pivotal bearing at one end on a prolongation of the axle and extending toward the cutter-box, and a bracket, beside which the box is pivoted, having a sleeve on its rear face and end, through which said bar extends, the said bar being thus carried around the end of the cutter-box and then bent substantially parallel to the axle and then extended to a pivotal support beneath the axle, substantially as described.

7. In a mowing-machine, the combination with the cutter box and shoe mounted on a suitable swinging frame, of a frame-lifting lever fulcrumed on the frame of the machine and having a chain connecting its end with the swinging frame, a pawl locking said lever, and a pawl-operating lever pivoted beneath a foot-piece on the power end of the lift-lever and connected with the pawl, the end of said pawl-operating lever lying in a slot in the foot-piece and rising above the surface thereof, substantially as described.

In testimony whereof I have affixed my signature in presence of two witnesses.

JACK W. JAMES.

Witnesses:

FRANK HAWKINS,
M. L. YORK.