

(19)
(12)

(KR)
(Y1)

(51) 。 Int. Cl. ⁷
E06B 3/964

(45)
(11)
(24)

2001 10 10
20 - 0242582
2001 08 01

(21) 20 - 2001 - 0008827
(22) 2001 03 23

(73) 467 - 1 106 402

(72) 467 - 1 106 402

(74)

:

가 :

(54)

가

, 가
가

가

, L (1) ,
(1) (20,21) .

2

, ,

1

2

3 2

4 가

5

1: 2:

10: 101:

20,21: 100:가

100a: 102:

, 가 , 가
가

1 가

100,100a) 가가 (100) (100a) , 가 (100,100a) (

가 가

가

가가
가

(

1 , 3 2 , 4 , 2
 , 5 , 가

(1) (100, 100a) L (101) 2 (2) (100,101) (1) (10) 가 (

(20,21) (100) (102) (1) (20,21) (, 102)

(20,21) (1) (1) (2) (2) (1) (20) (21)

(20,21)

(100a) (1) (20,21) 가 가 (100)

가 가 가

/

(57)

1.

L (1) ,

(1) (20,21)

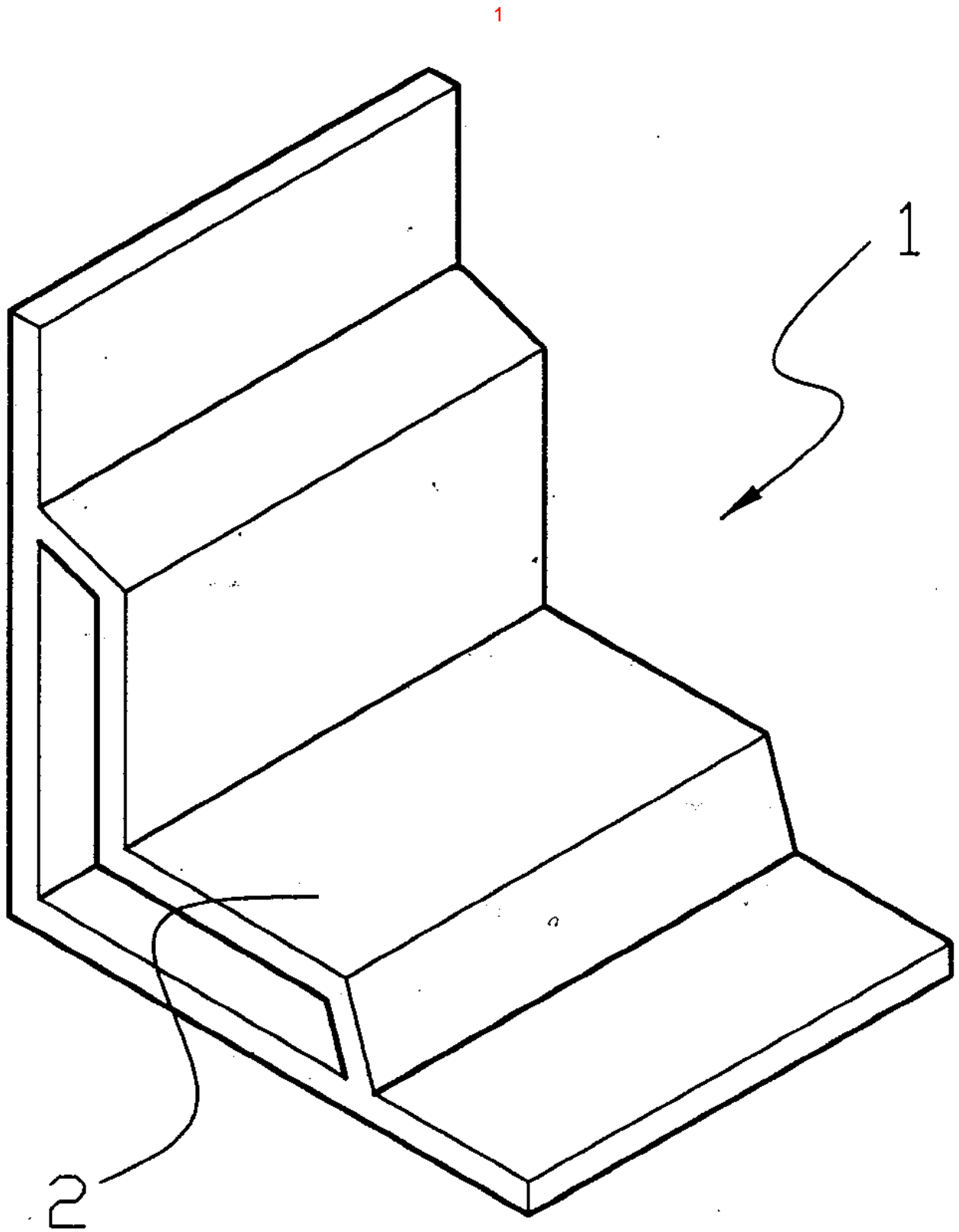

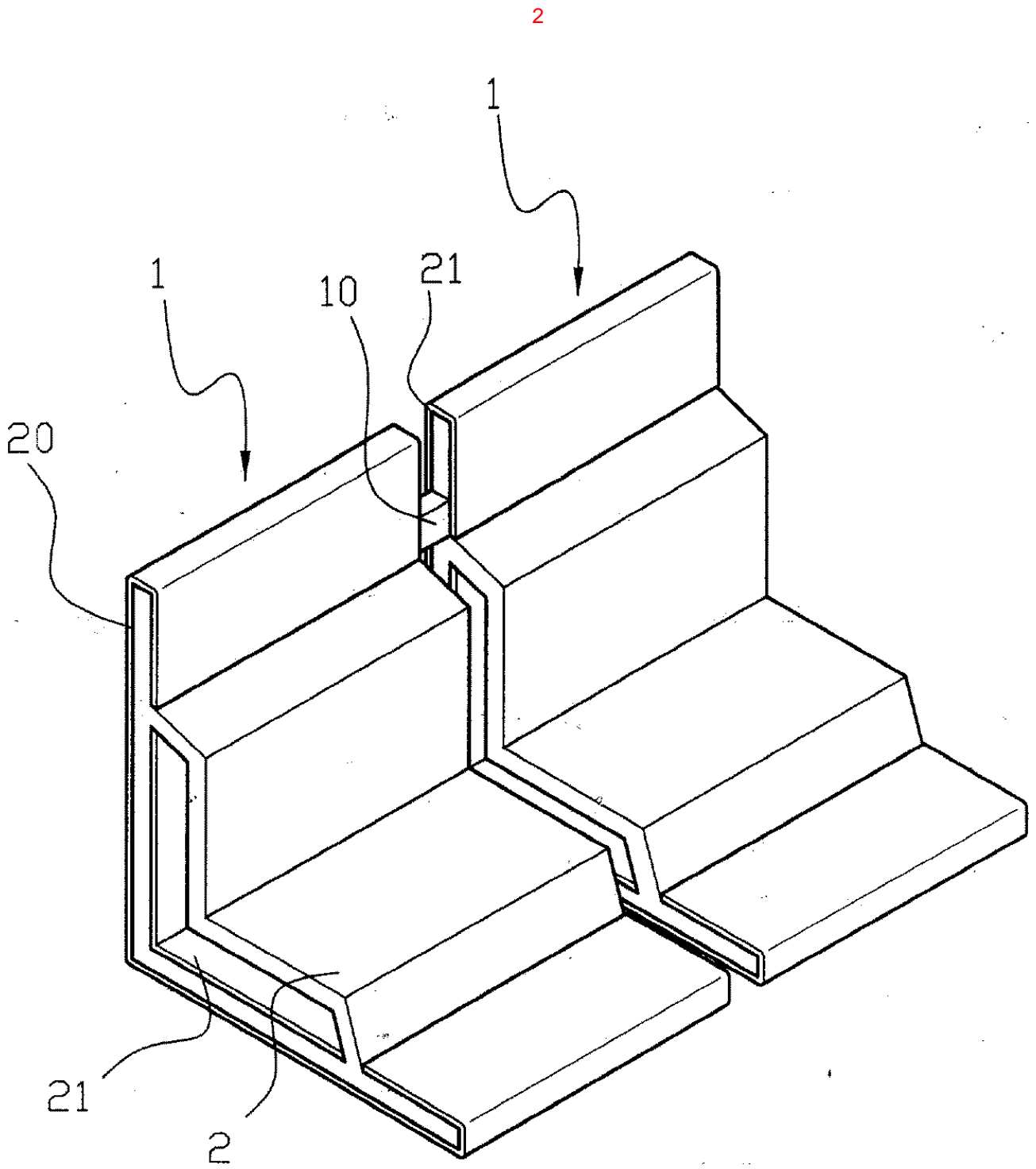

3

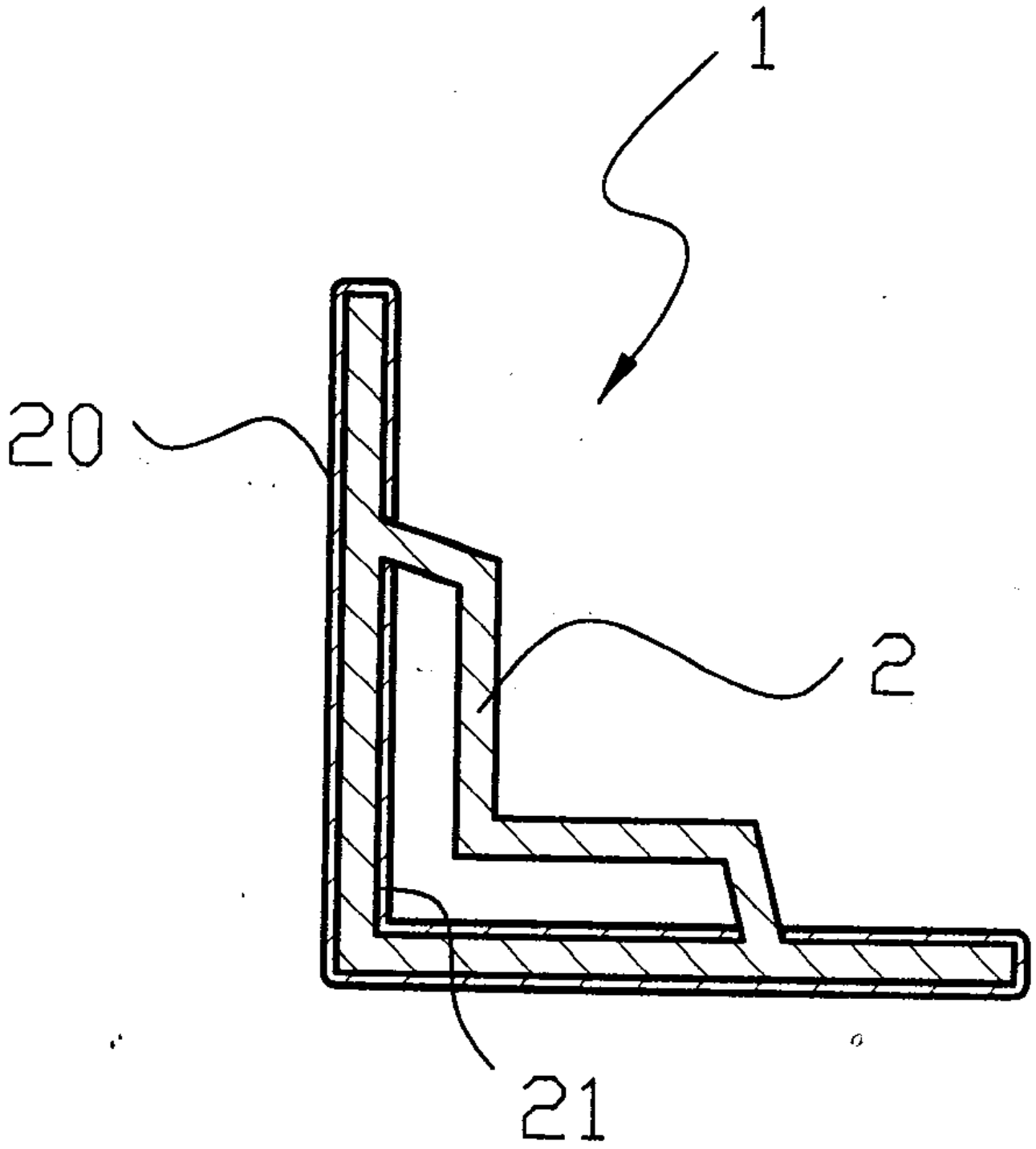

4

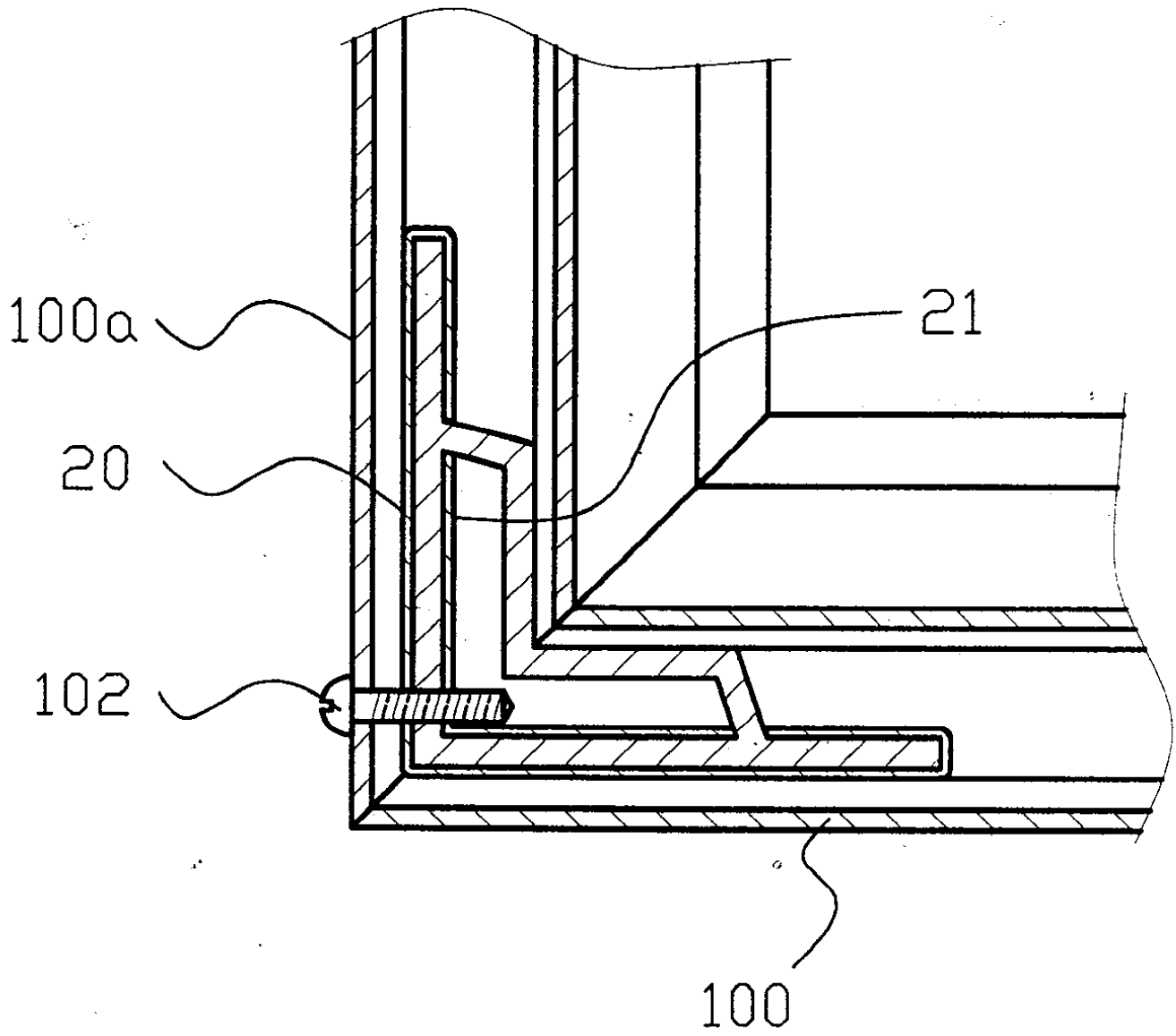

5

