

(19)



(11)

**EP 2 090 697 A2**

(12)

**EUROPEAN PATENT APPLICATION**

(43) Date of publication:

**19.08.2009 Bulletin 2009/34**

(51) Int Cl.:

**E01B 35/00 (2006.01)**

**E01B 35/02 (2006.01)**

(21) Application number: **09460002.0**

(22) Date of filing: **14.01.2009**

(84) Designated Contracting States:

**AT BE BG CH CY CZ DE DK EE ES FI FR GB GR  
HR HU IE IS IT LI LT LU LV MC MK MT NL NO PL  
PT RO SE SI SK TR**

Designated Extension States:

**AL BA RS**

(72) Inventors:

• **Anigacz, Wojciech**  
**45-267 Opole (PL)**

• **Okos, Daniel**  
**45-217 Opole (PL)**

(30) Priority: **14.02.2008 PL 38445808**

(74) Representative: **Surmiak, Wiesława Halina et al**

**Ul. Stanisława Mikołajczyka 5**  
**45-271 Opole (PL)**

(71) Applicant: **Politechnika Opolska**  
**45-271 Opole (PL)**

**(54) Device for indirect indication of rail axis**

(57) A device for indirect indication of rail axis is provided with a shearing clamp (2), the clamp having rotating rolls (5) at the end of its arms, wherein at the end of each

arm (2) of the shearing clamp a roll deflection limiter (3) is located, e.i. a cuboid with an opening, while the rolls (5) are located on self-aligning axles.

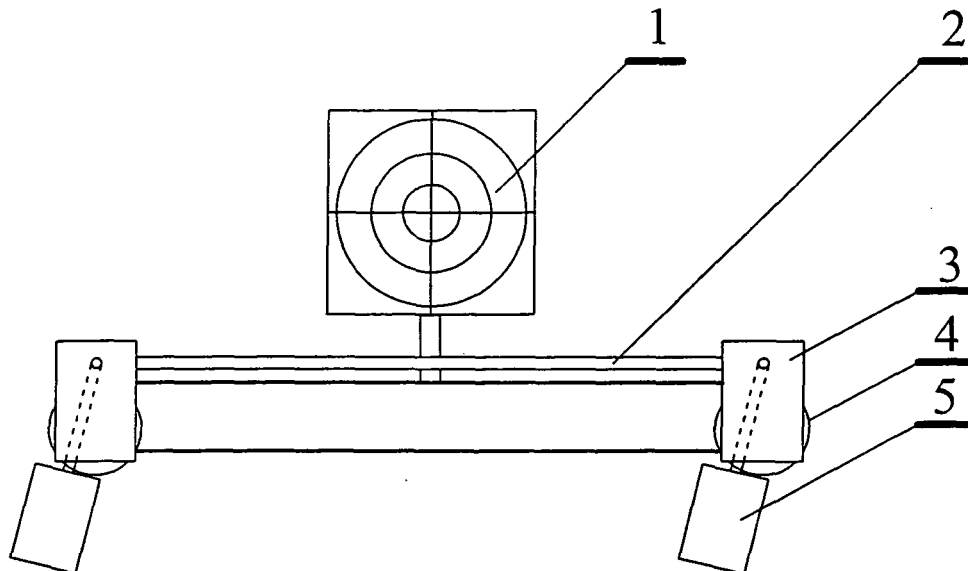

Fig. 1

**EP 2 090 697 A2**

**Description**

**[0001]** A device for indirect indication of rail axis, in particular a bridge rail, is an object of this invention.

**[0002]** Such a device, referred to in the publication titled "Engineering Geodesy" by W. Janusz, collective work, volume II, PPWK, Warsaw 1994, page 445, a special levelling head for indirect reproduction of rail head, namely a shearing clamp, provided with immovable grips at the end of the arms, touching lateral surfaces of the rail head. The levelling head is aligned on the rail the way that, once aligned, the centre of the target is situated in the vertical plane containing the rail axis.

Also known is a levelling head, namely a shearing clamp provided with four rotating rolls at the end of the arms, two pieces at each end. The rolls move along lateral surfaces of the bridge rail head. A geodesic aiming device is installed on the clamp.

**[0003]** The known special levelling heads provided with grips at the end of the arms have to be moved along the rail and fixed in other measuring point, which is troublesome and time-consuming, and also requires the staff intervention. The known levelling heads, though enable movement of the instrument along the rail, do not assure stability of the device, which is not propitious to safe and failure-free realization of measurements.

**[0004]** The essence of the invented device for indirect indication of rail axis consists in that at the end of each arm of the shearing clamp located is a cubicoidal roll deflection limiter with an opening. The rolls are installed on self-aligning axles.

**[0005]** The invented device for indirect indication of rail axis enables its safe movement and a stable position on the rail, by pressing the device to the upper surface of the rail head, thanks to self-aligning rolls that change the deflection direction, according to the turn of the device movement direction. At the same time, it allows to more precisely indicate the rail head, and thus the rail axis, which helps to obtain more accurate results of the measurement.

**[0006]** The invention object, a real model, has been described on the drawing that illustrates a scheme of the device for indirect indication of rail axis. The invented device is composed of shearing clamp **2** with rolls **5** located on self-aligning axles that are connected with the arms ends. The shearing clamp **2** has been installed on carriage **4**. At the end of each arm located is a cubicoidal roll deflection limiter with an opening **3** that points out magnitude of the roll deflection **5** of the vertical. A target **1** is located at intersection of the shearing clamp, that indicates the axis of the rail head, and thereby the rail axis. Rolls **5** rotate along lateral surfaces of the rail head, and their deflection from the vertical is changing according to the turn of direction of the invented device movement. Location of the target **1**, and thereby that of the rail head, which corresponds to the rail axis position, are readable at determined places.

**Claims**

1. The device for indirect indication of rail axis is provided with a shearing clamp, with rotating rolls at the end of its arms; **it is characterized as follows:** at the end of each arm (**2**) of the shearing clamp located is the roll deflection limiter (**3**), a cubicoid with an opening, while the rolls (**5**) are located on self-aligning axles.

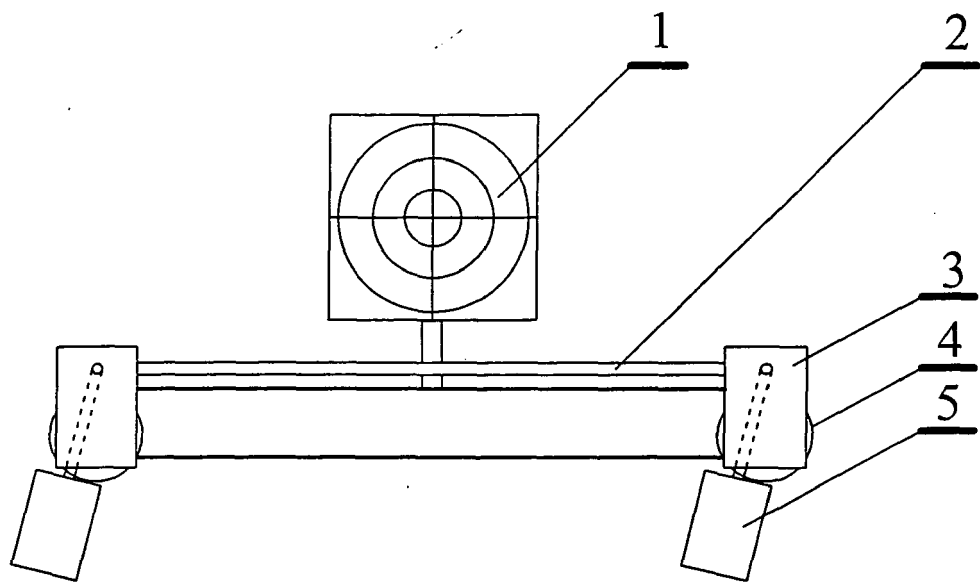

Fig. 1

**REFERENCES CITED IN THE DESCRIPTION**

*This list of references cited by the applicant is for the reader's convenience only. It does not form part of the European patent document. Even though great care has been taken in compiling the references, errors or omissions cannot be excluded and the EPO disclaims all liability in this regard.*

**Non-patent literature cited in the description**

- **W. Janusz.** *Engineering Geodesy*, 1994, vol. II, 445  
**[0002]**