

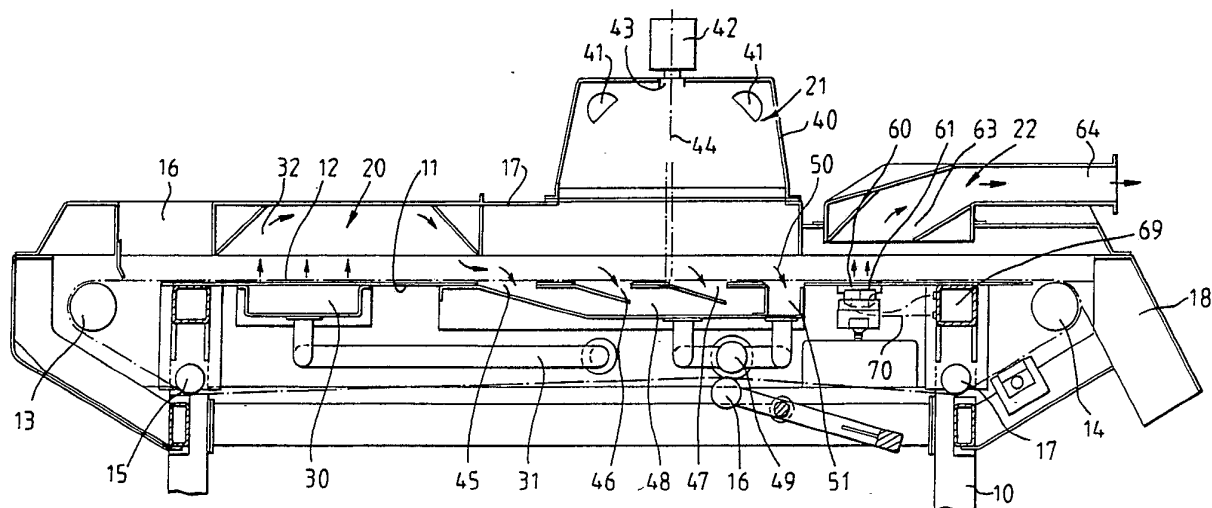

INTERNATIONAL APPLICATION PUBLISHED UNDER THE PATENT COOPERATION TREATY (PCT)

<p>(51) International Patent Classification ⁵ : A24C 5/36, A24B 1/04 B07C 5/342</p>	A1	<p>(11) International Publication Number: WO 90/06065</p> <p>(43) International Publication Date: 14 June 1990 (14.06.90)</p>									
<p>(21) International Application Number: PCT/GB89/01434</p> <p>(22) International Filing Date: 30 November 1989 (30.11.89)</p> <p>(30) Priority data:</p> <table border="0"> <tr> <td>8827895.7</td> <td>30 November 1988 (30.11.88)</td> <td>GB</td> </tr> <tr> <td>8827896.5</td> <td>30 November 1988 (30.11.88)</td> <td>GB</td> </tr> <tr> <td>8829184.4</td> <td>14 December 1988 (14.12.88)</td> <td>GB</td> </tr> </table> <p>(71) Applicant (for all designated States except US): GBE INTERNATIONAL PLC [GB/GB]; GBE House, Newbury Road, Andover, Hampshire SP10 4DW (GB).</p> <p>(72) Inventors; and (75) Inventors/Applicants (for US only) : BIRD, Derek, G. [GB/GB]; Hawthorn Hedges, Horsebridge Road, Kings Somborne, Stockbridge, Hampshire SO20 6PT (GB). SPICER, John, William [GB/GB]; 44 St. Anne's Close, Badger Farm, Winchester, Hampshire FO22 4LQ (GB). COLE, Michael [GB/GB]; Bramleys, Manor Rise, Anna Valley, Nr Andover, Hampshire SP11 7LS (GB).</p>		8827895.7	30 November 1988 (30.11.88)	GB	8827896.5	30 November 1988 (30.11.88)	GB	8829184.4	14 December 1988 (14.12.88)	GB	<p>(74) Agent: BROOKES & MARTIN; High Holborn House, 52/54 High Holborn, London WC1V 6SE (GB).</p> <p>(81) Designated States: AT (European patent), BE (European patent), CH (European patent), DE (European patent), ES (European patent), FR (European patent), GB (European patent), IT (European patent), JP, LU (European patent), NL (European patent), SE (European patent), US.</p> <p>Published <i>With international search report.</i></p>
8827895.7	30 November 1988 (30.11.88)	GB									
8827896.5	30 November 1988 (30.11.88)	GB									
8829184.4	14 December 1988 (14.12.88)	GB									

(54) Title: IMPROVEMENTS IN OR RELATING TO APPARATUS FOR REMOVING FOREIGN MATERIAL FROM A STREAM OF PARTICULATE MATERIAL



(57) Abstract

The invention relates to apparatus for removing foreign matter from a stream of particulate material as part of the processing of that material; and finds particular but not exclusive use in the removal of foreign matter such as paper or other items from a stream of tobacco material as part of the pre-processing of tobacco in the manufacture of cigarettes. The apparatus for removing foreign matter from a stream of material comprises conveyor means arranged to carry the stream of material from an inlet (16), successively past an agitation stage (20) in which the material is agitated to spread it evenly over the conveyor means, a detection stage (21) at which foreign matter is detected optically, and an ejection stage (22) at which detected foreign matter is removed from the material, and is delivered to an exit (18) from the apparatus.

FOR THE PURPOSES OF INFORMATION ONLY

Codes used to identify States party to the PCT on the front pages of pamphlets publishing international applications under the PCT.

AT	Austria	ES	Spain	MG	Madagascar
AU	Australia	FI	Finland	ML	Mali
BB	Barbados	FR	France	MR	Mauritania
BE	Belgium	GA	Gabon	MW	Malawi
BF	Burkina Fasso	GB	United Kingdom	NL	Netherlands
BG	Bulgaria	HU	Hungary	NO	Norway
BJ	Benin	IT	Italy	RO	Romania
BR	Brazil	JP	Japan	SD	Sudan
CA	Canada	KP	Democratic People's Republic of Korea	SE	Sweden
CF	Central African Republic	KR	Republic of Korea	SN	Senegal
CG	Congo	LI	Liechtenstein	SU	Soviet Union
CH	Switzerland	LK	Sri Lanka	TD	Chad
CM	Cameroon	LJ	Luxembourg	TG	Togo
DE	Germany, Federal Republic of	MC	Monaco	US	United States of America
DK	Denmark				

IMPROVEMENTS IN OR RELATING TO APPARATUS FOR REMOVING FOREIGN
MATERIAL FROM A STREAM OF PARTICULATE MATERIAL

This invention relates to apparatus for removing foreign matter from a stream of particulate material as part of the processing of that material; and finds particular but not exclusive use in the removal of foreign matter such as paper or other items from a stream of tobacco material as part of the pre-processing of tobacco in the manufacture of cigarettes.

The invention is particularly useful, although not exclusively so, in the removal of foreign matter which has a significantly lower terminal velocity in air than the components of the main stream of material from which the foreign matter is removed, for instance the removal of paper from tobacco. A typical example of the application of the invention is in the removal of paper remnants from tobacco material when cigarettes which have faults in them after their manufacture, are broken up so that the tobacco therein can be re-used in making fresh cigarettes. In such a case it is necessary to remove the remnants of the cigarette papers from the tobacco.

The foreign matter in the stream of material may be detected by optical means. A suitable optical detection system is described in our copending international Patent Application published under the numbers W088/03063, which describes a system for optically detecting the presence of an unacceptable particle across the width of the stream of material, and then rejecting it by operating a specific

solenoid valve, to provide compressed air to a specific nozzle, located adjacent the path of the stream of material, to blow a detected unacceptable particle from the main stream flow. However, due to the rapid diffusion of air as it leaves the nozzle in such a prior arrangement, significant quantities of good material are also rejected with the unacceptable particle from the product stream, particularly when the material being treated is tangleable material such as tobacco. Further airborne debris and dust is generated in the areas of the machine with consequent inconvenience.

An object of the present invention is to provide an apparatus which improves the discrimination of the removal action, whilst limiting the generation of airborne debris from the process of unacceptable particles removal.

A further object of the invention is to provide a method whereby the rejection area is tightly controlled and any dust generated by the rejection process is carried away with the rejected particles of foreign matter rather than being diffused into the atmosphere surrounding the machine and in the prior art arrangement.

Accordingly the present invention provides apparatus for removing foreign matter from a stream of material comprising conveyor means arranged to carry the stream of material from an inlet, successively past an agitation stage in which the material is agitated to spread it evenly over the conveyor means, a detection stage at which foreign matter is detected optically, and an ejection stage at which

detected foreign matter is removed from the material, to an exit from the apparatus.

In order to promote a fuller understanding of the above and other aspects of the present invention an embodiment of the present invention will now be described by way of example only with reference to the accompanying drawings in which:

FIGURES 1 and 1A show a schematic side elevation of a machine embodying the invention,

FIGURE 2 shows a schematic block diagram of the electrical and electronics circuitry associated with the optical detection of the embodiment of Figure 1,

FIGURE 3 shows a schematic prospective view of an alternative feed arrangement for material to the embodiment of Figure 1,

FIGURE 4 shows a schematic diagram of an alternative arrangement for removing a foreign matter from the embodiment of Figure 1 and,

FIGURES 5 & 6 show schematic diagrams of alternative arrangements of Figure 4.

FIGURE 1 shows a schematic cross sectional side elevation of a machine for removing foreign matter from a stream of material being processed, particularly for removing such matter as paper from a stream of tobacco material.

The machine comprises a floor mounted frame 10, which includes a support surface indicated generally at 11, for a conveyor belt 12 which is carried between main rollers 13 &

14 over the support surface 11, and tensioned by jockey pulleys 15, 16 & 17. The belt 12 is perforated so as to make it readily porous to air, while still being able to support the acceptable particle size of the material to be processed without it passing through the conveyor. An inlet 16 for material to be processed is provided at the left hand end of the machine as seen in Figure 1 in the form of an aperture in an upper cover structure 17 which covers and encloses the run of the conveyor belt 12 over the support 11. An outlet 18 is provided at the right hand end of the machine in the form of a discharge chute to carry treated material away to some other process.

The conveyor belt 12 carries material from left to right as seen in Figure 1 from the inlet 16 through a first stage 20 in which the material on the belt is agitated or fluidized, partly to spread the material evenly over the belt, and partly to attempt to bring the foreign matter to be removed to the surface of the material on the belt, an inspection stage 21 at which the foreign material is detected, a foreign matter ejection stage 22 at which the foreign matter is removed from the material on the belt 12, and finally to the exit 18 to leave the machine.

The first stage 20 is arranged with an air chamber 30 immediately beneath the support 11, so that air supplied to the chamber 30 through a conduit 31, may pass through the belt 12 into the material thereon at that stage to agitate and/or fluidize it. Because the foreign matter to be

removed, often has a lower terminal velocity in air than the tobacco material to be treated, apart from spreading the material more evenly across the width of the belt, this agitation or fluidization, causes the foreign material, particularly paper, to rise to the surface of the material on the belt. The cover 17 is formed with an upper chamber 32 over the chamber 30, to collect any dust or other material blown from the material on the belt, and this is extracted by air flow from the chamber 32 to the next stage as will be discussed below.

The inspection stage 21 comprises a light box 40 having an open lower face which cooperates with an aperture in the top of the housing 17. The light box contains lamps, indicated schematically at 41, arranged to illuminate the material on the belt 12 as it passes beneath the light box. An optical scanning device 42 is mounted above the light box 40 and arranged to observe through an aperture 43 in a plane 44, a narrow band across the width of the material on the conveyor belt 12. The scanning device 42 is mounted on a separate support frame (not shown) to be supported in position from the ground independantly of the rest of the machine, so that it is not subjected to the vibrations created by the machine.

At the detection stage 21, the support 11 is provided with apertures 45, 46 & 47 beneath the belt 12 which are a communication with a chamber 48 and thus to an air extraction conduit 49. A further aperture 50 is provided beneath the

belt in communication with the chamber 51 also in communication with the extraction conduit 49. This means that air may be drawn through the material from the belt, through the belt and out through the conduit 49 carrying with it dust from the chamber 32 as mentioned above, and from the material generally. The drawing of air through the belt also helps to hold the material on the belt more firmly to carry it reliably beneath the scanning device 42.

In operation the scanning device 42 scans as mentioned a narrow band across the width of the belt, and optically (and electronically) detects in a manner to be discussed below, any foreign matter on the material passing beneath it on the belt 12 so that it can be ejected from the belt 12 at the ejection stage 22 in a manner to be discussed below.

The ejection stage 22 comprises two rows 60 and 61 of nozzles, 62, shown in more detail in Figures 1a, disposed beneath the belt 12 in the support 11. The rows of nozzles 60 and 61 are arranged so that the nozzle 62 are staggered across the width of the belt, and in this embodiment there are thirty two nozzles 62 in each row thus providing a nozzle to cover each of 64 distinct strips or bands across the width of the belt. The nozzle 62 are arranged to supply a blast of air through the belt 12 and the material on it, to eject the foreign material detected off the belt 12. A hood 63 is embodied in the upper cover 17 connected to an outlet conduit 64 through which air is continuously drawn, so that any

foreign material ejected by a nozzle 62 is carried away from the housing 17 and from the machine. As seen in Figure 1a, the rows of nozzles 60 and 61 are carried on a support bar 65 adjustably supported on screw adjusters 66, from a beam 67 forming part of the machine frame 10. This means that the nozzle 62 can be positioned accurately immediately beneath the belt 12. Each nozzle 62 is provided with an associated solenoid operated air valve 68, to control the supply of air to the nozzle from a reservoir chamber 69 forming part of the frame 10, by flexible conduits 70.

Material passes from the ejection stage 22 to fall into the exit chute at the exit 18 and the machine.

FIGURE 3 shows in schematic block form the electric/electronic circuit for controlling the solenoid valves 68 in response to detection of foreign matter by the scanning device 42.

The scanning device 42 is arranged to provide a video signal on the line 70, corresponding to the light intensity reflected from the material on the belt 12 in a single line scan across the width of the belt. The scanning device 42 also provides a synchronisation pulse on the line 71 to coincide with the commencement of the video signal line on the line 70. The sync pulse is passed to a decoder 72 which embodies a counter arranged to divide the time interval of the video line into a series of elements, in this embodiment 64, to divide the width of the belt 12 in effect into 64 bands. The counter is started by the sync pulse on line 71.

The video signal is passed to an amplifier 73 the gain of which is controlled by control means 74, in dependence from the count from the counter in the decoder 72, indicative of the instantaneous position across the belt 12 that is represented by that instant in the video signal. By this means the response of the scanning device may be corrected to make it substantially linear despite the effects of uneven illumination and of scanning geometry, which would otherwise tend to make the scanning device more sensitive at the centre of the belt than at the sides. The decoder 72 provides an output on the line 75 during the scan time of the video signal on the line 70 to activate a sampling means 76 which stores the content of the video signal passed through it from the amplifier 73. An averaging device 77 produces a background compensation signal from averaging the video signal stored in the sample device 76, and a signal representative of the average output of the scanning device 42 is passed to a summing amplifier indicated at 78, together with a pre-set value for a detection threshold which is set on the line 79. The output of the summing amplifier 78, and of the amplifier 73, are passed to a comparator 80, so that when the video signal from the scanning device 42 exceeds a pre-set threshold above the background output, the comparator 80 gives an output signal on the line 81. Thus when foreign matter is detected by the scanning device, by giving a video output markedly different from the background level, a matter detected signal occurs on the line 81. The count from the

counter in the decoder 72 is also passed on the a line 82 to a band or strip decoding means 83, in conjunction with the foreign matter detected signal on the line 81, so that a corresponding signal occurs on an appropriate one of a series of parallel outputs 84, which corresponds to the band or strip across the belt at which the foreign matter was detected. The outputs 84 are each connected to a respective one of the series parallel shift registers indicated by the block 85. These shift registers are each clocked to carry any input signal along their logical length, in synchronism with the speed of the belt 12 through the machine; so that an output occurs, on one of the series of parallel lines 86, at an instant corresponding to the arrival of detected foreign matter at the ejection stage 22. The output lines 26 are connected through driver circuits in the block 87 to the solenoids 68 to control the air nozzles 62, so that the appropriate one is energised, to eject the detected foreign matter. Pre-set means indicated at 88 may be used to alter the starting point in any of the shift registers of the block 85, to adjust the operation of the nozzle 62 for instance to compensate for their staggered relationship. Similar means 89 may be provided for controlling the length of time that the solenoids 68 are operated thus to control the length of air blast in operation of the machine.

Thus it can be seen that the embodiment provides apparatus for receiving material, spreading it out on a conveyor, passing it beneath a scanning device to detect

foreign matter and subsequently ejecting that foreign matter, down stream from the scanning device, to separate it from the main stream of material which then leaves the machine.

FIGURE 3 shows an alternative arrangement for feeding material to the belt 12 of the embodiment of Figure 1. In this arrangement material to be fed to the machine passes down a chute 100 to fall onto the conveyor belt 12 across a perforated plate 101. An air chamber 102 is provided behind the plate 101 and air is supplied to that chamber under pressure so that a series of air jets are emitted from the plate 101. Thus the material is subjected to these air jets as it passes across the plate 101 and is subjected to an agitating and mixing effect somewhat similar to the process known as winnowing.

FIGURE 4 shows an alternative arrangement of the ejection stage 22. In this arrangement instead of air jets being positioned beneath the belt, suction nozzles 110 are arranged above the belt and connected to an air extraction device 111 by means of a conduit 112. The nozzles 110 are individually movable in vertical direction from a position shown in full in Figure 4 to a position, shown at 113 in dotted outline, immediately above the belt 12. The suction nozzles 110 correspond in number, and may correspond in arrangement, to the air nozzles 62. On detection of foreign matter in the material on the belt 12, the appropriate nozzle 110 is moved down at the appropriate instant to draw the unwanted foreign matter out of the material on belt 12, to be

collected in a container 114.

FIGURES 5 & 6 show alternative arrangements for the nozzles 110 of Figure 4. In these arrangements the nozzles are mounted on a transverse bar 115 which is in turn carried on a link 116 driven by an associated crank 117, to cause the nozzles to move in an elliptical path as indicated in the diagram. With this arrangement when foreign matter is detected, at the appropriate instant in time, the crank 117 is caused to rotate so that the nozzles 110 execute their elliptical path to come down onto the foreign matter carried on the material on the belt 12, follow it briefly along the path of the belt, and then lift it away for disposal. The appropriate nozzle 110 is connected to a source of vacuum by a respective solenoid valve 119 by way of a flexible pipe 118 carried on a mounting beam 120.

The arrangements of Figures 4, 5 & 6 may be used with a belt 12 which is not perforated, in which case it would be preferable to use the feed means of Figure 3. In such an arrangement the chambers 48 and 51 beneath the detection stage may also be omitted. In some circumstances the arrangements of Figures 4, 5 & 6 may be used together with the air jets of Figures 1 or 1a with a perforated belt 12.

Thus it can be seen that the embodiment of the invention provides apparatus for receiving a stream of material, spreading it upon on moving belt, detecting foreign matter lying in that material and removing from the belt before the stream of material leaves the machine.

CLAIMS:

1. Apparatus for removing foreign matter from a stream of material comprising conveyor means arranged to carry the stream of material from an inlet (16), successively past an agitation stage (20) in which the material is agitated to spread it evenly over the conveyor means, a detection stage (21) at which foreign matter is detected optically, and an ejection stage (22) at which detected foreign matter is removed from the material, to an exit (18) from the apparatus.

2. Apparatus as claimed in Claim 1, in which said conveyor means comprises a perforated or porous conveyor belt (12) supported over a run between the inlet and outlet by means of a support (11).

3. Apparatus as claimed in Claim 2, in which said agitation stage comprises means (30,31) for blowing air through a portion of the conveyor belt from below, to agitate or fluidize the material thereon, means (32) for containing any dust, or other small particles, which may leave the material, and means (48,49,51) for extracting such dust from the apparatus.

4. Apparatus as claimed in Claim 3, in which the means for containing the dust comprises a hood disposed over that portion of the belt.

5. Apparatus as claimed in Claim 2, in which said agitation stage comprises an inclined perforated plate (101)

disposed between the inlet and the conveyor belt, and means (102) to blow air through the plate so that material passing from the inlet to the belt over the perforated plate is agitated or fluidized.

6. Apparatus as claimed in any one of Claims 2 to 5, in which said detection stage comprises a light box (46) disposed over the conveyor means, including means (41) to illuminate the material on the conveyor belt, and scanning means (42) arranged to optically scan a narrow band across the width of the conveyor belt to detect foreign matter in or on the material on the conveyor, and to determine its location across the width of the conveyor belt.

7. Apparatus as claimed in Claim 6, in which the scanning means determines such position across the width of the conveyor belt in one of a plurality of discrete strips or bands along the conveyor belt.

8. Apparatus as claimed in Claim 6, in which means (48,49,51) is provided for extracting air from beneath a portion of the conveyor belt beneath the light box, to hold the material on the conveyor belt over the detection stage.

9. Apparatus as claimed in Claim 7, in which the extracting means comprises a number of apertures (45,46,47) in said support communicating with one or more chambers (48,51) disposed beneath the support and communicating with extraction means.

10. Apparatus as claimed in Claim 8, as dependant upon Claim 3, in which said extracting means provides the

means for extracting dust from said agitation stage.

11. Apparatus as claimed in any one of Claims 2 to 9, in which the ejection stage comprises a plurality air of jets (62) arranged beneath the conveyor belt, a selected one of which is operable in response to detection of foreign matter at said detection stage to remove that foreign matter.

12. Apparatus as claimed in Claim 11, in which the air jets are individually controllable in response to the detection of foreign matter.

13. Apparatus as claimed in Claim 11 or 12 as dependant upon Claim 7, in which the air jets are arranged in one or more rows across the width of the conveyor belt, with one air jet being disposed beneath each such strip or band of the conveyor belt.

14. Apparatus as claimed in Claim 11, 12 or 13, in which delay means is provided operative between the scanning means and the air jets to synchronise the operation of the air jets with the arrival of detected foreign matter at the ejection stage from the detection stage.

15. Apparatus as claimed in Claim 14, in which the delay means comprises an electronic shift register which is arranged to be clocked in synchronisation with the movement of the conveyor belt.

16. Apparatus as claimed in Claim 15, in which a respective shift register is provided for each air jet.

17. Apparatus as claimed in any one of Claims 11 to

16, in which the ejection stage comprises a hood (63) disposed over the air jets and connected to extraction means to carry away ejected foreign matter.

18. Apparatus as claimed in any one of Claims 1 to 9, in which the ejection stage comprises a plurality of suction nozzles (110) arranged over the conveyor belt, and movable between an inoperative position clear of the belt and an operative position immediately above the material on the belt in response to detection of foreign matter at the detection stage to remove that foreign matter.

19. Apparatus as claimed in Claim 18, in which the suction nozzles are individually controllable in response to the detection of foreign matter.

20. Apparatus as claimed in Claim 18 or 19, in which the suction nozzles move substantially along with the conveyor belt while in their operative position.

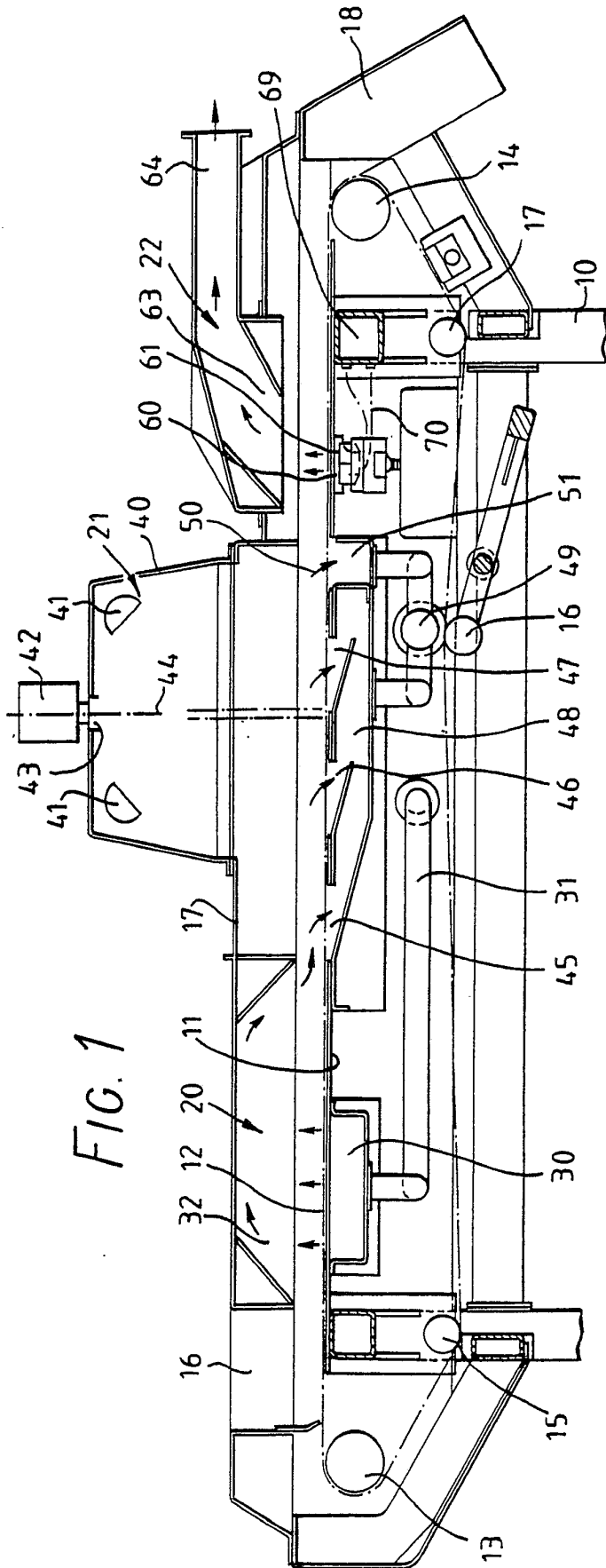

FIG. 1

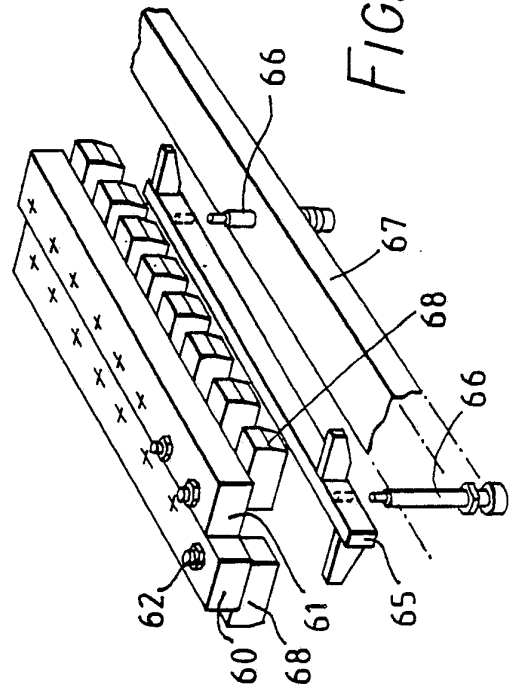

FIG. 1A

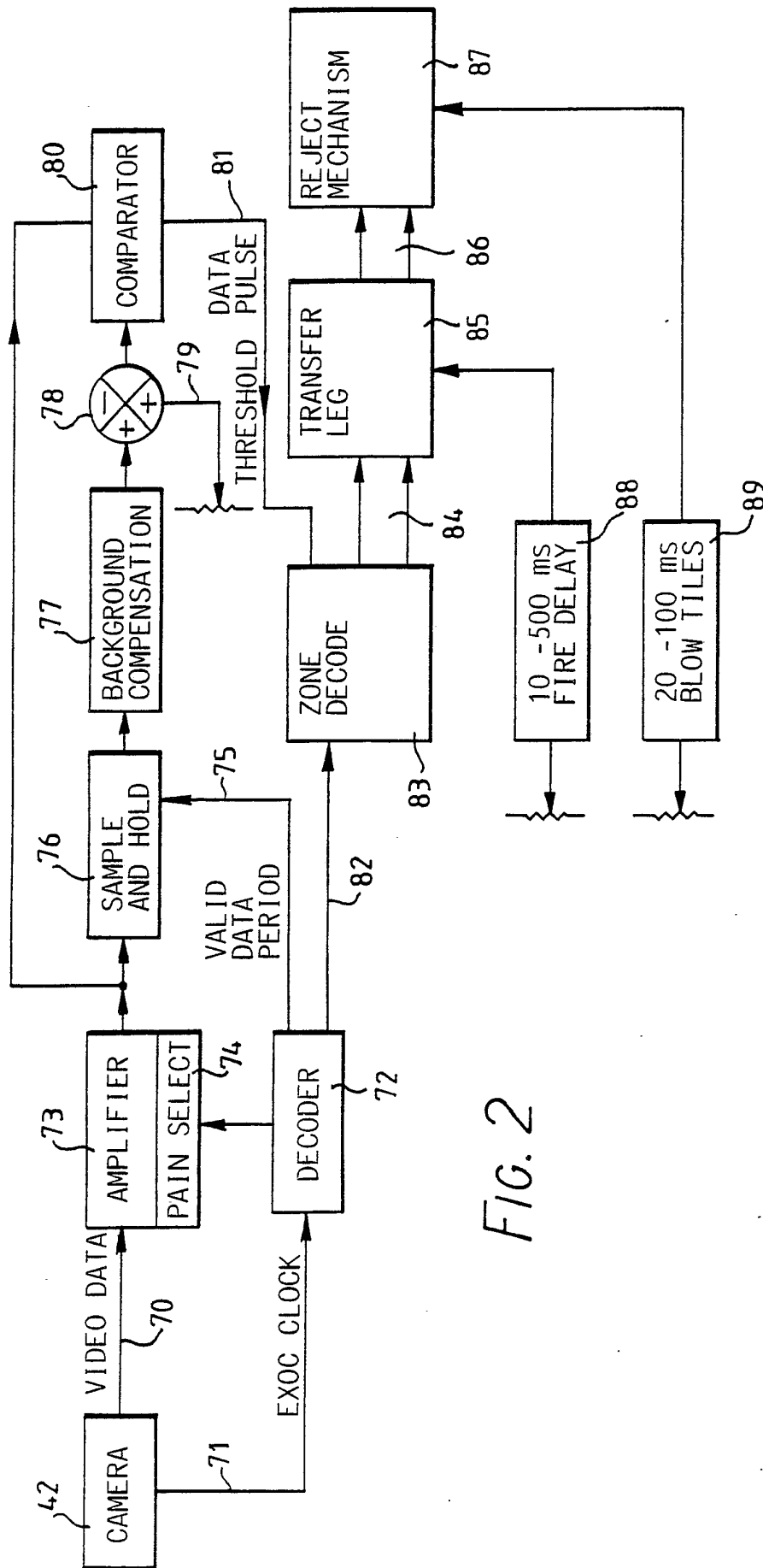
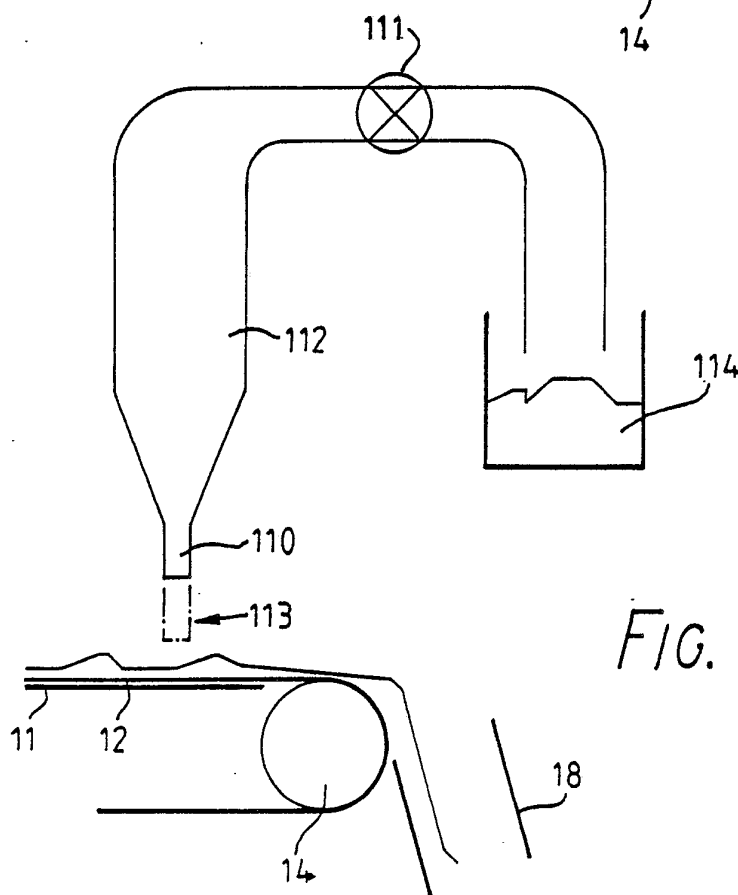
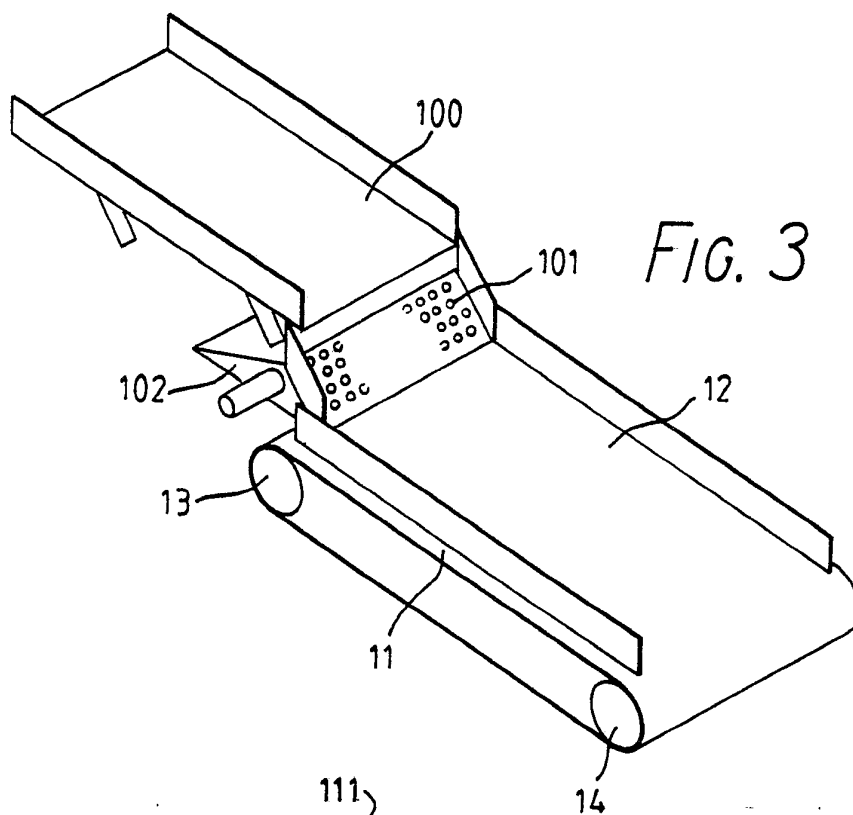
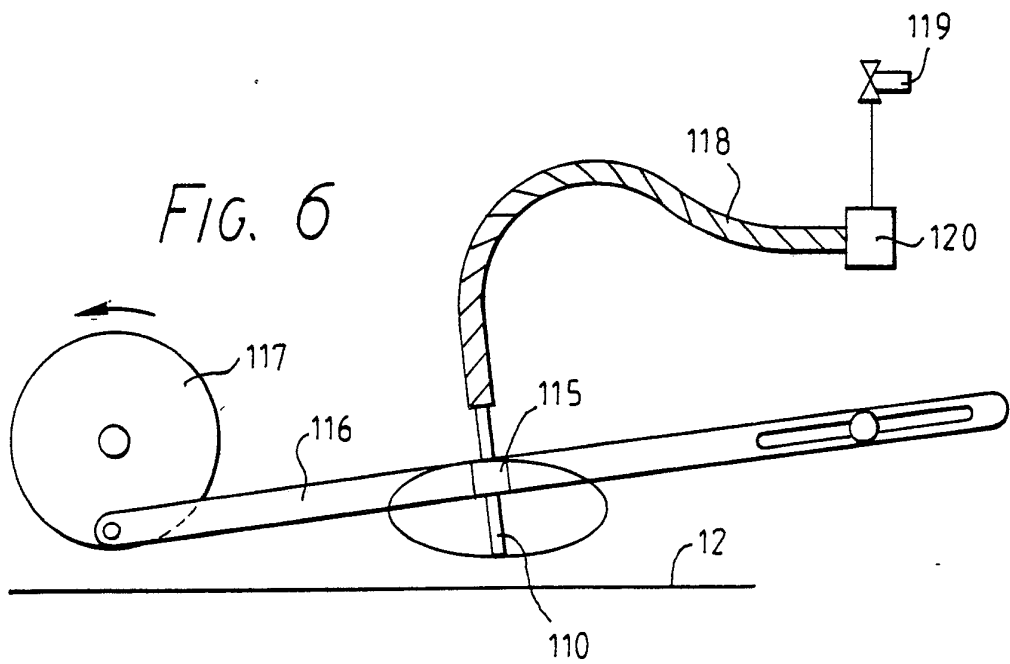
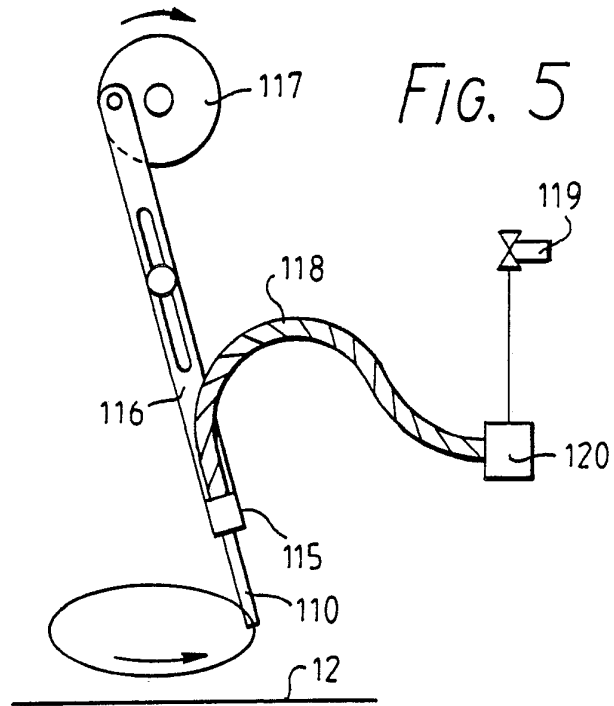

FIG. 2





INTERNATIONAL SEARCH REPORT

International Application No

PCT/GB 89/01434

I. CLASSIFICATION OF SUBJECT MATTER (if several classification symbols apply, indicate all)⁶
 According to International Patent Classification (IPC) or to both National Classification and IPC
 Int.Cl. 5 A24C5/36 ; A24B1/04 ; B07C5/342

II. FIELDS SEARCHED

Minimum Documentation Searched ⁷	
Classification System	Classification Symbols
Int.Cl. 5	A24C ; A24B ; B07C ; B03B

Documentation Searched other than Minimum Documentation
 to the Extent that such Documents are Included in the Fields Searched⁸

III. DOCUMENTS CONSIDERED TO BE RELEVANT⁹

Category ¹⁰	Citation of Document, ¹¹ with indication, where appropriate, of the relevant passages ¹²	Relevant to Claim No. ¹³
X	DE,U,8531196 (STENZEL) 20 February 1986 see the whole document ---	1
A	US,A,4056463 (HANSEN) 01 November 1977 see the whole document ---	1, 6, 7, 11, 12, 14
A	US,A,3685650 (WALTHER) 22 August 1972 see the whole document ---	1, 6, 7, 18
A	NL,A,8304371 (THOMASSEN) 16 July 1985 see page 5, lines 12 - 35; figures 3, 4 ---	1, 6, 7, 11-14
A	EP,A,193308 (PHILIP MORRIS INC.) 03 September 1986 see page 5, line 1 - page 6, line 33; figures 1, 2 ---	1, 6, 7, 11-14
	-/--	

¹⁰ Special categories of cited documents :

<p>"A" document defining the general state of the art which is not considered to be of particular relevance</p> <p>"E" earlier document but published on or after the international filing date</p> <p>"L" document which may throw doubts on priority claim(s) or which is cited to establish the publication date of another citation or other special reason (as specified)</p> <p>"O" document referring to an oral disclosure, use, exhibition or other means</p> <p>"P" document published prior to the international filing date but later than the priority date claimed</p>	<p>"T" later document published after the international filing date or priority date and not in conflict with the application but cited to understand the principle or theory underlying the invention</p> <p>"X" document of particular relevance; the claimed invention cannot be considered novel or cannot be considered to involve an inventive step</p> <p>"Y" document of particular relevance; the claimed invention cannot be considered to involve an inventive step when the document is combined with one or more other such documents, such combination being obvious to a person skilled in the art.</p> <p>"&" document member of the same patent family</p>
--	---

IV. CERTIFICATION

Date of the Actual Completion of the International Search <p style="text-align: center; font-size: 1.2em;">12 MARCH 1990</p>	Date of Mailing of this International Search Report <p style="text-align: center; font-size: 1.2em;">27.03.90</p>
International Searching Authority <p style="text-align: center;">EUROPEAN PATENT OFFICE</p>	Signature of Authorized Officer <p style="text-align: center;">RIEGEL R.E. </p>

III. DOCUMENTS CONSIDERED TO BE RELEVANT (CONTINUED FROM THE SECOND SHEET)

Category °	Citation of Document, with indication, where appropriate, of the relevant passages	Relevant to Claim No.
A	DE,C,598130 (ROTH) 07 June 1934 see the whole document	2, 3
A	US,A,4186836 (WASSMER) 05 February 1980	

ANNEX TO THE INTERNATIONAL SEARCH REPORT
ON INTERNATIONAL PATENT APPLICATION NO.

PCT/GB 89/01434
SA 32687

This annex lists the patent family members relating to the patent documents cited in the above-mentioned international search report.
The members are as contained in the European Patent Office EDP file on
The European Patent Office is in no way liable for these particulars which are merely given for the purpose of information. 12/03/90

Patent document cited in search report	Publication date	Patent family member(s)	Publication date
DE-U-8531196	20-02-86	None	
US-A-4056463	01-11-77	CA-A- 1053530 DE-A, C 2737512 GB-A- 1578957	01-05-79 23-02-78 12-11-80
US-A-3685650	22-08-72	None	
NL-A-8304371	16-07-85	None	
EP-A-193308	03-09-86	US-A- 4657144 AU-A- 5407686 CA-A- 1243752 JP-A- 61195333	14-04-87 28-08-86 25-10-88 29-08-86
DE-C-598130		None	
US-A-4186836	05-02-80	None	