

T. CHARLTON.
GEARING.

APPLICATION FILED MAR. 14, 1911.

1,001,819.

Patented Aug. 29, 1911.

2 SHEETS-SHEET 2.

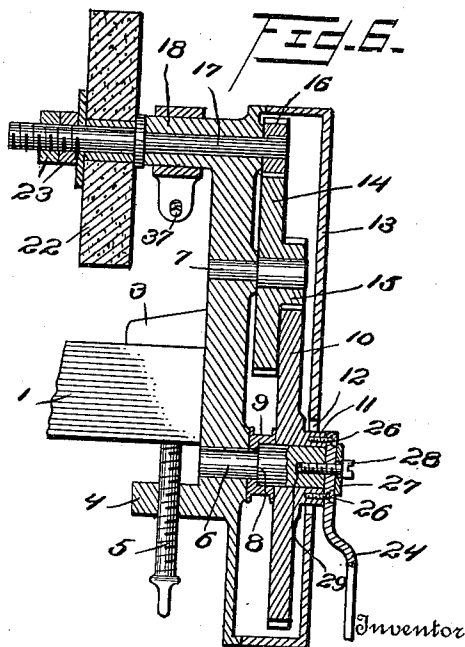
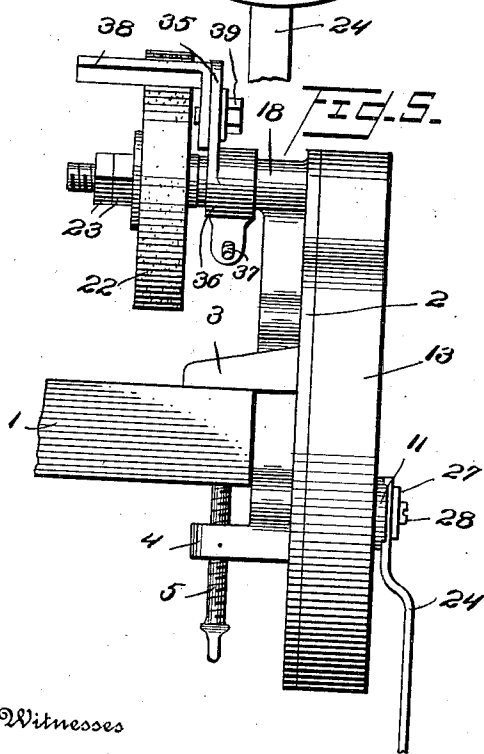
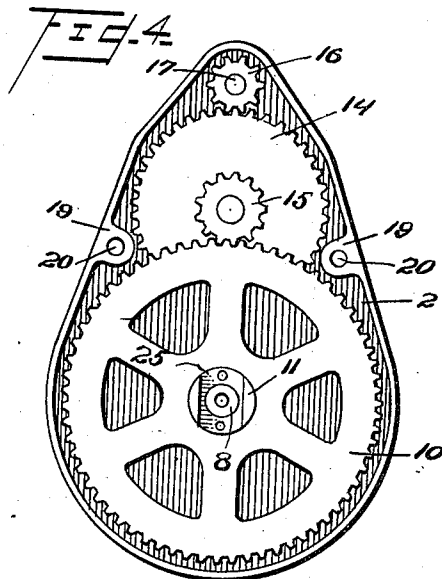
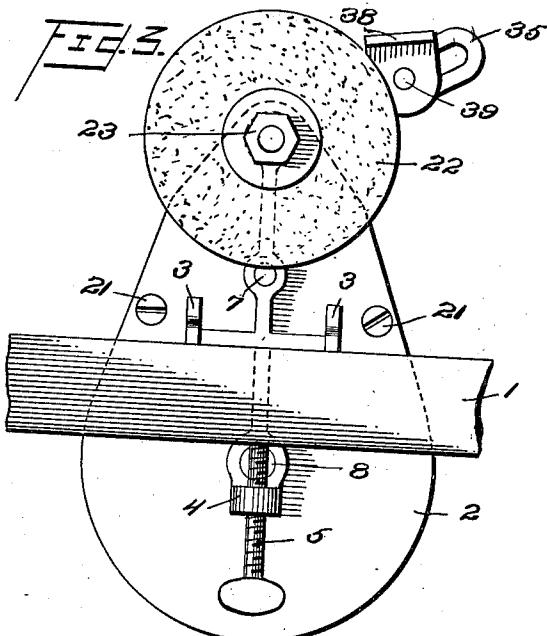

Witnesses

H. Strass
R. H. Krenkel.

Inventor
Thomas Charlton

By Joshua R. T. Totten
Attorney

UNITED STATES PATENT OFFICE.

THOMAS CHARLTON, OF PHILADELPHIA, PENNSYLVANIA, ASSIGNOR TO STERLING MACHINE WORKS, OF PHILADELPHIA, PENNSYLVANIA.

GEARING.

1,001,819.

Specification of Letters Patent. Patented Aug. 29, 1911.

Application filed March 14, 1911. Serial No. 614,321.

To all whom it may concern:

Be it known that I, THOMAS CHARLTON, a citizen of the United States, residing at Philadelphia, in the county of Philadelphia and State of Pennsylvania, have invented certain new and useful Improvements in Gearing, of which the following is a specification.

My invention relates to improvements in gearing, and more particularly to gearing adapted for use in connection with grinders, the object of the invention being to provide an improved gearing of this type which will impart the desired power transmission to minimize the expenditure of power to obtain the desired speed.

It is a well known fact that grinding wheels unless they obtain a relatively high speed wear rapidly, and the faster the wheel turns, the slower the wear, hence it is the effort of all manufacturers to attain the highest speed with the least power, and this I believe I have done with my device.

A further object is to provide an improved mounting for the main driving gear, improved connection between the same and the crank, and improved tool guiding means capable of adjustment from side to side in accordance with the position of the grinder.

With these and other objects in view, the invention consists in certain novel features of construction and combinations and arrangements of parts, as will be more fully hereinafter described and pointed out in the claims.

In the accompanying drawings: Figure 1, is a view in elevation illustrating my improvements attached to the table and operating by means of a treadle. Fig. 2, is a similar view of the grinding machine showing it operated by an ordinary crank and showing the machine partly in section to illustrate the manner of connecting the tool guide. Fig. 3, is a view in elevation of the back of the grinder. Fig. 4, is a view in elevation showing the gearing when the covering plate or casing is removed. Fig. 5, is an edge view of Fig. 3, and Fig. 6, is a view in vertical longitudinal section through the center of the grinder.

1, represents a table or support to which my improved grinder is secured, the backing plate 2 of said grinder having integral lugs 3 to be positioned above the table and an integral screw-threaded lug 4 to be positioned

below the table and having a set screw 5 therein to clamp the grinder on the table. In this back plate 2, two journal pins 6 and 7 respectively are secured by forcing said pins into openings in the plate or otherwise rigidly securing them. The lower journal pin 6 is shouldered as shown at 8, and fits within a spacing cup 9. On this journal 6, and against the spacing cup 9, is the main driving gear 10, the outwardly projecting hub portion 11 of said gear extending through an opening 12 in the casing or cover 13, all of which parts will be more fully hereinafter described.

On journal pin 7, integral gears 14 and 15 are mounted to turn, gear 15 being relatively small, and in mesh with the main driving gear 10, while gear 14 is relatively large and meshes with a pinion 16 on a driven shaft 17, which projects through an integral sleeve 18 on plate 2 at the upper end of the latter.

By reference particularly to Fig. 4, it will be noted that plate 2 on its outer face is provided with two integral lugs 19, having screw-threaded openings 20 therethrough for the reception of screws 21, which screw into the cover or casing 13, and tightly hold the latter in place.

In order that a perfect joint may be had between the plate 2 and the cover or casing 13, the edge of the casing 13 and the face of plate 2 with the lugs 19, are ground smooth, so that when the casing fits against the plate, the joint is that of two ground surfaces against each other, and thereby dust and foreign matter are excluded.

On the shaft 17, a grinding wheel 22 is secured by nuts 23, and this grinding wheel is turned by the gears above described when the driving gear 10 is turned by a crank arm 24.

The hub 11 of gear 10 at its outer end is made with a groove or recess 25 of a width to receive crank arm 24, and said crank arm is secured to the hub by small screws 26.

A washer 27 is located against the outer face of the crank arm 24, and through this washer 27 and the crank arm 24, a screw 28 is positioned and screwed into a socket 29 in journal 6, so that the crank arm is not only locked to the driving gear, but the driving gear is securely held on the journal, and the frictional engagement of the driving gear with the cup 9 is regulated by means of this screw 28.

Crank arm 24 may be operated by means of an ordinary handle 29 connected to the crank arm at one end as shown in Fig. 2, or it may be operated by means of a treadle 30 as shown in Fig. 1. The treadle illustrated in Fig. 1 is pivotally supported at one end in a bracket 31 secured to the floor, and at its other end is connected by an adjustable link 32 with the crank arm 24. To effect this connection between the link 32 and the crank 24, an opening 33 is provided in the crank 24 for the reception of a thumb screw 34.

On the sleeve 18, my improved tool rest is mounted and comprises a slotted arm 35 having a split clamp 36 at one end which is clamped onto the sleeve 18 by means of a set screw 37. In this slotted arm 35, an angle bracket 38 is adjustably secured by means of a set screw 39, and it will be noted that the bracket 38 may be adjusted radially with relation to the grinding wheel 22, that the arm 35 may be adjusted in the arc of a circle so as to position it either to the right or to the left of the grinding wheel, and the bracket 35 may be positioned on either side of the wheel, and either in the position shown or in the exact reverse position, which will be readily understood. This arrangement of tool holder enables the device to be used either right or left in accordance with the position of the machine on the table, and the particular workman using the same.

Various slight changes might be made in the general form and arrangement of parts described without departing from my invention, and hence I do not limit myself to the precise details set forth, but consider myself at liberty to make such changes and alterations as fairly fall within the spirit and scope of the appended claims.

Having thus described my invention, what I claim as new and desire to secure by Letters Patent is:

1. In a grinding machine, the combination with a back plate, and an outer casing secured on the back plate, of a journal secured in the back plate, a driving gear mounted to turn on said journal and having a hub thereon, said casing having an opening through which said journal and said hub project, said hub having a groove or recess therein, a crank arm in said groove or

recess, screws securing said crank arm to the hub, a screw securing said crank arm to the journal, and a train of gearing connected to said driving gear and inclosed within the casing, substantially as described. 55

2. In a grinding machine, the combination with a back plate, an integral rearwardly projecting sleeve at the upper end of said back plate, two journal pins secured in the back plate, the lower journal pin of two diameters forming a shoulder, a cup positioned against the back plate through which said journal projects and into which said shoulder of the journal bears, a driving gear mounted to turn on the journal and having a hub thereon, an outer casing secured to the back plate and having an opening through which said hub and said journal project, said hub projecting outward beyond the journal and having a groove or recess therein, a crank arm fitting in said groove or recess, screws securing said crank arm to said hub, a screw projected through said crank arm and screwed into the journal, integral small and large gears on the other of said journals, the smaller gear meshing with the driving gear, a shaft mounted in the said sleeve, and a pinion on said shaft meshing with the larger of said last-mentioned gears, substantially as described. 60 65 70 75 80

3. In a grinding machine, the combination with a back plate having integral lugs projecting rearwardly from the back plate, a set screw in one of said lugs to clamp said back plate on a support, and forwardly projecting journals secured in said back plate, of a casing conforming in shape to the outline of the back plate, said back plate and said casing having milled engaging faces, screws projected through the back plate and screwed into the casing, a train of gears mounted on said journals in the casing, means for turning said gears, and a shaft projecting through the back plate and driven by said gears, substantially as described. 85 90 95

In testimony whereof I have signed my name to this specification in the presence of two subscribing witnesses.

THOMAS CHARLTON.

Witnesses:

J. GORDON HENDEL,
MARGARET CRAIG.