

A. J. HOOD.  
 GAGE AND WORK DROPPING DEVICE FOR PLATEN PRINTING PRESSES.  
 APPLICATION FILED OCT. 7, 1909.

976,366.  
 MODEL.

Patented Nov. 22, 1910.

2 SHEETS—SHEET 1.

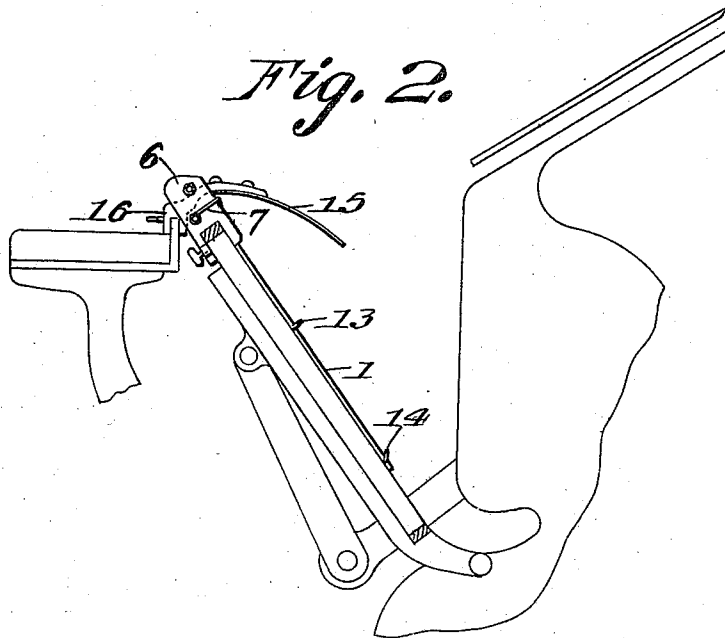
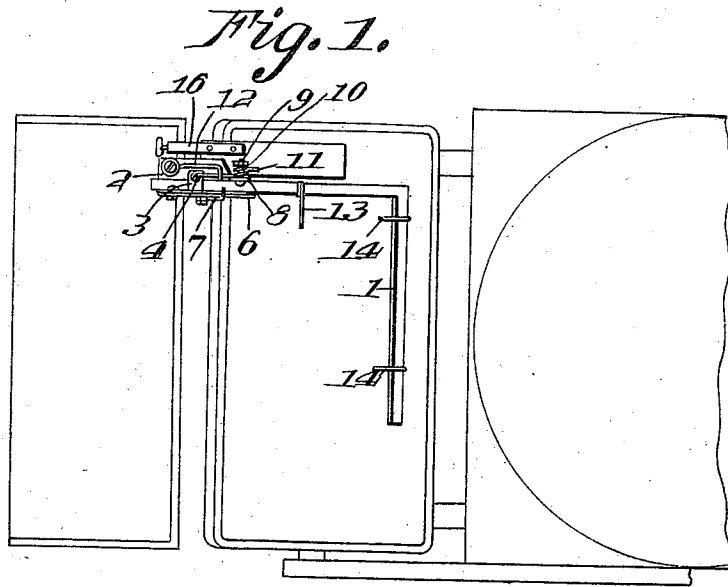

Witnesses  
*E. D. Brown.*  
*C. H. Griesbauer.*

Inventor  
*Alexander J. Hood.*  
 By *A. B. Wilson & Co.*  
 Attorneys

A. J. HOOD.  
 GAGE AND WORK DROPPING DEVICE FOR PLATEN PRINTING PRESSES.  
 APPLICATION FILED OCT. 7, 1909.

976,366.  
 MODEL.

Patented Nov. 22, 1910.  
 2 SHEETS—SHEET 2.

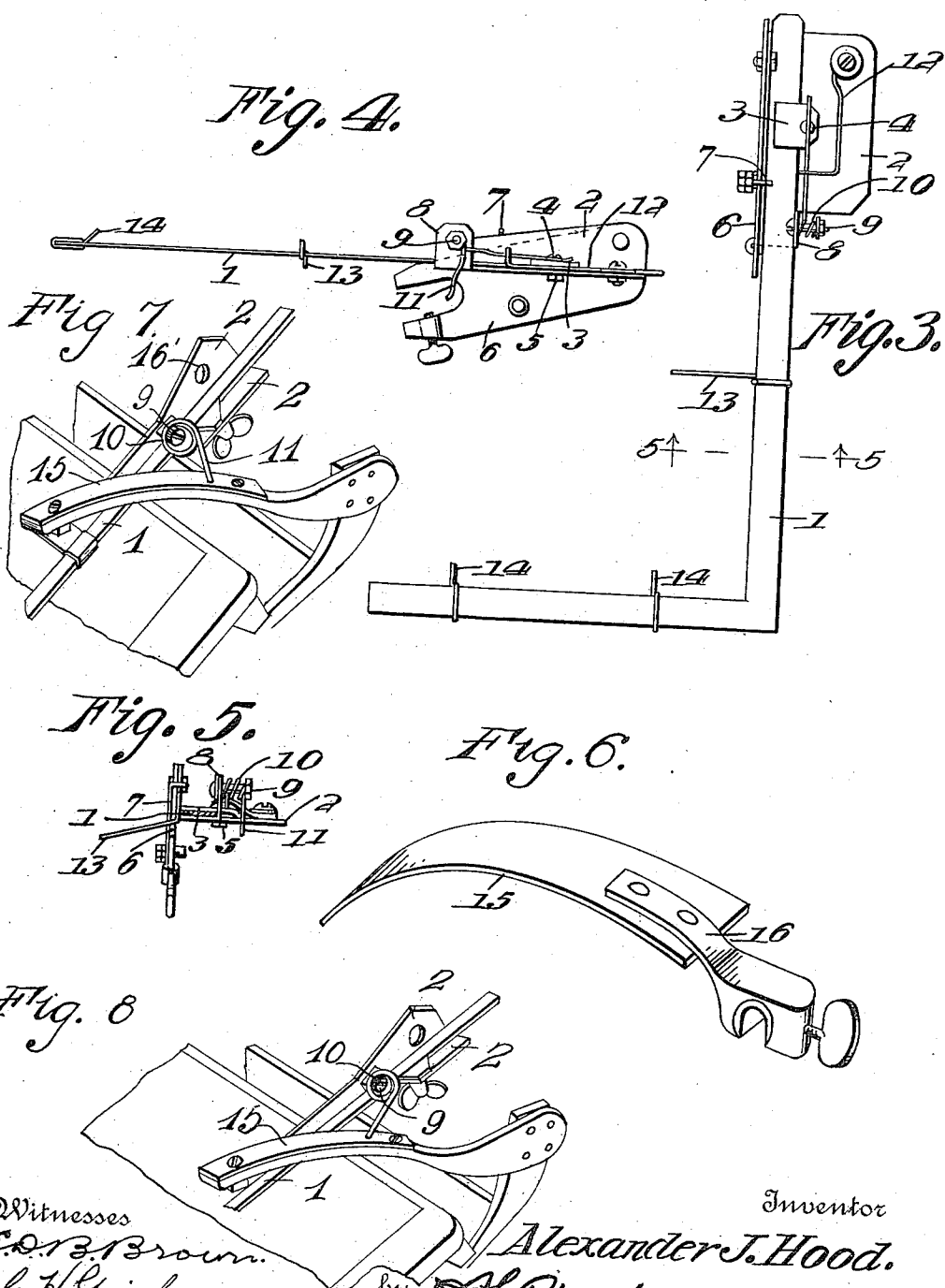

Witnesses  
 C. D. Brown.  
 C. H. Giesbauer.

Inventor  
 Alexander J. Hood.  
 By A. Blumson & Co.  
 Attorneys

# UNITED STATES PATENT OFFICE.

ALEXANDER J. HOOD, OF MUSCODA, WISCONSIN.

GAGE AND WORK-DROPPING DEVICE FOR PLATEN PRINTING-PRESSES.

976,366.

Specification of Letters Patent. Patented Nov. 22, 1910.

Application filed October 7, 1909. Serial No. 521,449. (Model.)

To all whom it may concern:

Be it known that I, ALEXANDER J. HOOD, a citizen of the United States, residing at Muscodia, in the county of Grant and State of Wisconsin, have invented certain new and useful Improvements in Gages and Work-Dropping Devices for Platen Printing-Presses; and I do declare the following to be a full, clear, and exact description of the invention, such as will enable others skilled in the art to which it appertains to make and use the same.

This invention relates to improvements in gages and work dropping or discharging devices for platen printing presses.

One object of the invention is to provide an improved construction of gage and dropping mechanism adapted to be automatically operated when the press is closed to hold the work in position on the platen and when the press is opened to release the work and start the discharge or delivery of the same from the press.

Another object is to provide a device of this character which will be simple, strong and durable in construction, efficient and reliable in operation, and well adapted to the purpose for which it is designed.

With the foregoing and other objects in view, the invention consists of certain novel features of construction, combination and arrangement of parts, as will be more fully described and particularly pointed out in the appended claims.

In the accompanying drawings, Figure 1 is a plan view of a portion of a printing press, showing the application of the invention; Fig. 2 is a vertical section through the same, showing a side elevation of the invention; Fig. 3 is an enlarged plan view of the gage, dropper and the attaching mechanism for the same; Fig. 4 is a side view of one side of the gage and the parts connected thereto; Fig. 5 is a cross sectional view on the line 5-5 of Fig. 3; Fig. 6 is a detail view of the curved operating arm or track. Fig. 7 is a detail perspective view showing the position of the spring finger 11 when the platen is in closing position; Fig. 8 is a similar view showing the position of the parts when the platen is in opening position.

Referring more particularly to the drawings, 1 denotes the gage which consists of a right angularly formed bar, one end of which is adjustably secured to a head 2 by a suitable clamping device. The clamping

device here shown comprises a plate 3 adapted to be engaged with the upper side of the gage bar and a screw 4 which is inserted through the plate and through the head 2 and is provided on its under side with a clamping nut 5 which, when screwed up against the under side of the head, will draw the plate 3 downwardly into tight engagement with the gage bar, thus clamping the same against the upper side of the head and holding the gage in adjusted position.

The head 2 is preferably provided with an arm 2' extending upwardly at right angles thereto and which is pivotally connected to an attaching plate 6 adapted to be secured to the upper edge of the platen by any suitable attaching mechanism, thus pivotally supporting the gage in operative position on the platen, as clearly shown in the drawings. Secured to one side of the attaching plate 6, is a stop finger 7 which projects above the plate 6 and is adapted to be engaged by the upper edge of the head 2 when the latter is raised to limit its upward movement.

On the head 2, is formed an upwardly projecting lug 8, in which is arranged a laterally projecting bolt 9. On the bolt 9 is arranged a coiled spring 10, one end of which projects downwardly below the head and forms a spring operating finger 11. The opposite end of the spring 10 preferably bears against the upper side of the head and is yieldingly held by the free end of a retaining spring 11 the other end of which is secured to the head 2 by a screw or any other suitable means. The spring 12 serves to hold the gage down in yielding engagement with the platen when the press is being closed.

On the longitudinally extending portion of the gage bar, is arranged a throw-off finger 13 which, when the gage is in operative position, fits closely against the platen beneath the work and when the press is opened after the impression has been made and the gage is raised by the spring finger 11 dragging behind and bearing on a track to be described, will lift the work and start the discharging movement of the same from the platen. The work when thus started, will readily fall from the platen into a suitable receptacle without the necessity of the operator touching the work. On the laterally projecting portion of the gage bar are the usual or any suitable gage pins 14 which

are adjustably connected with the bar and serve as stops to hold the work in position on the platen while the impression is being made.

5 Secured to the feed board of the press, is a curved convexo-concave operating plate or track 15, said plate being secured to an arm 16, which in turn is clamped to the feed board by a clamping screw or other suitable fastening device, as shown. The gage is attached to the platen, adjacent to and at one side of the operating plate 15, and in such relative position thereto that when the platen carrying the work is closed or moved toward the type, the spring operating finger 11 which always drags behind will engage and ride over the plate 15 as shown in Fig. 7, thus holding the gage down in yielding engagement with the platen and holding the work in position on the platen, while the impression is being made. The finger 11 dragging behind as shown in Fig. 7, causes the spring 10 to exert a downward pressure on the gage. After the impression has been made on the work and the platen begins to move back or open, the spring operating finger 11 will turn and bear on the curved operating plate 15 as shown in Fig. 8 thereby lifting the gage and causing the throw-off finger 13 to raise the work and start the same on its discharging movement from the platen, thus dispensing with the necessity of the operator removing or in any way touching the work after the impression has been made.

From the foregoing description, taken in connection with the accompanying drawings, the construction and operation of the invention will be readily understood without requiring a more extended explanation.

Various changes in the form, proportion and the minor details of construction may be resorted to without departing from the principle or sacrificing any of the advan-

tages of the invention, as defined in the appended claims.

Having thus described my invention, what I claim is:

1. In a gage and work dropping device for printing presses, an attaching mechanism having a stop finger, a gage carrying head pivotally mounted on said attaching means, a gage bar adjustably secured to said head, a throw-off finger secured to said gage bar, a spring operating finger arranged on said head, and a curved operating plate secured to the press and adapted to be engaged by said operating finger to hold the gage in yielding engagement with the platen while the latter is being closed and to lift the gage and throw-off finger while the platen is being opened.

2. In a gage and work dropping device for printing presses, a head, means to attach said head to the platen of the press, a gage bar, a clamp arranged on said head and adapted to adjustably secure said gage bar thereto, gage pins arranged on said bar, a throw-off pin also arranged on the bar, a spring operating finger connected to said head, a retaining spring arranged on the head and adapted to coact with said spring finger to yieldingly hold the gage bar in engagement with the platen, a curved operating plate secured to the printing press in position to be engaged by said spring operating finger, when the platen is opened and closed thereby holding the gage bar against the platen in its closing movement and lifting said bar and throw-off finger from the platen when the latter is being opened.

In testimony whereof I have hereunto set my hand in presence of two subscribing witnesses.

ALEXANDER J. HOOD.

Witnesses:

A. C. V. ELSTON,  
R. B. McINTYRE.