

J. R. BROWN & W. A. FOSKETT.
Automatic Fire-Extinguishers.

No. 166,451.

Patented Aug. 10, 1875.

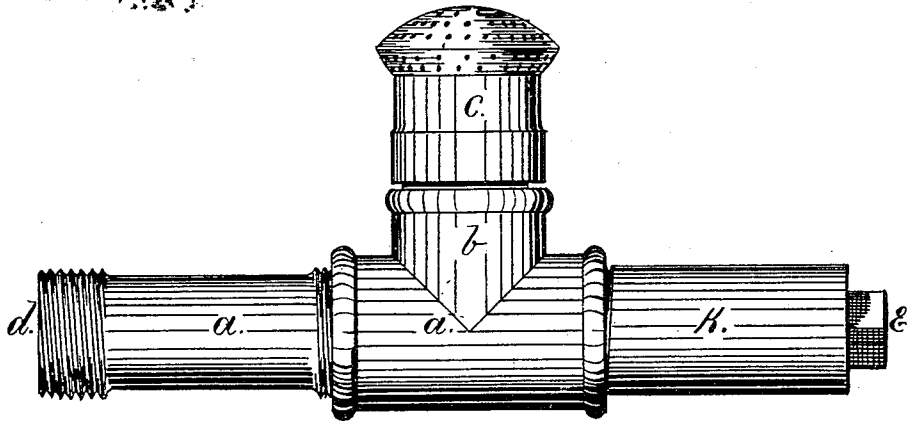

FIG. I.

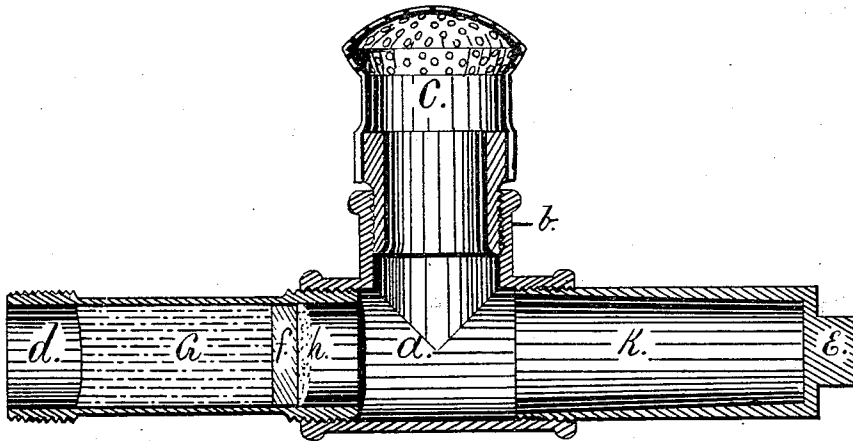

FIG. II.

WITNESSES

L. P. Langworthy
R. W. Eaton.

INVENTOR.

Joseph R. Brown
William A. Foskett
by Joseph A. Miller
his Attorney

UNITED STATES PATENT OFFICE.

JOSEPH R. BROWN AND WILLIAM A. FOSKETT, OF NEW HAVEN, CONN.

IMPROVEMENT IN AUTOMATIC FIRE-EXTINGUISHERS.

Specification forming part of Letters Patent No. **166,451**, dated August 10, 1875; application filed January 4, 1875.

To all whom it may concern:

Be it known that we, JOSEPH R. BROWN and WILLIAM A. FOSKETT, both of the city of New Haven, State of Connecticut, have invented a new and useful Improvement in Automatic Fire-Extinguishers; and we hereby declare that the following is a full, clear, and exact description of the same, which will enable others skilled in the art to make and use the same, reference being had to the accompanying drawings forming part of this specification.

Figure I is a perspective view, showing the device and the arrangement of the rose-sprinkler on the same. Fig. II is a section of the same, showing the interior of the device.

Similar letters of reference indicate corresponding parts.

This invention has reference to that class of fire-extinguishers in which the heat of a fire, by raising the temperature of the apartment above the normal or any fixed temperature, automatically lets on the water to that part of the apartment or building, and thus extinguishes the fire.

The object of the invention is to insure the prompt action of the apparatus as soon as the temperature reaches the fixed point. Another object is to prevent the accumulation of impurities contained in water and liable to precipitate and form a cement, and thus prevent the release of the water when the temperature is raised by a fire. Still another object of the invention is to prevent the water in the pipes reaching the soldered joints, and thus absorb the heat and delay the action of the extinguisher.

The nature of this invention consists in placing a plug within the apparatus, held in place by a suitable solder, and protected by a core of a substance which is a poor conductor of heat, as is more fully set forth hereinafter.

In the drawings, A is a cylindrical pipe, having a screw-socket at each end and a branch at *b*, to which the rose-sprinkler C is secured. One end of the pipe A is secured to the supply-pipe *d*, and the other is closed by the plug E. *f* is a metal disk, fitting loosely into the pipe A. Around the edge of this disk suitable solder is placed, and when the pipe A is heated to the melting-point of the solder and allowed

to cool, the disk will be firmly fixed and retained in the pipe A. After the disk *f* is thus secured the core G is placed into the pipe and forced, so as to fill up the pipe in front of the disk, as shown in Fig. II.

The core G is made of material which, being a poor conductor of heat, will melt at, or nearly at, the temperature at which the solder on the disk melts. In ordinary rooms or manufacturing establishments a temperature exceeding 120° Fahrenheit would indicate a fire. In such places stearine, paraffine, or wax may be used for the core, whereas, in drying-kilns, ovens, or rooms in which a higher temperature is maintained, the core G, as well as the solder by which the disk *f* is secured, must be composed of such material as will only melt when the temperature is raised sufficiently above the normal temperature to indicate that a fire has broken out, and thus at once automatically put the extinguisher into operation. That part of the pipe A between the disk *f* and the plug E is of slightly larger diameter than the rest, thus forming the pocket K; when, now, the heat generated by the fire softens the outside of the core G and melts the solder on the edge of the disk *f*, the water forces the disk and core into the box K, and allows a free flow of the water to the rose-sprinkler C, by which it is thrown in a fine spray on the fire automatically, and at such points only where the rise in temperature indicates that the fire exists.

When, in an automatic fire-extinguisher in which the melting of solder relieves a cup, valve, or disk, the water comes in contact with the disk, valve, or cup, the impurities in the water—such as lime or other earthy matter, or some metallic oxide—in the course of time form a solid and strong cement, firmly cementing the valve, disk, or cup to its seat, and when a fire breaks out in a building provided with such fire-extinguishers, the apparent security engendered by the certainty of the action of the apparatus, when first put up, is liable to cause the most disastrous consequences, and this is almost certain to happen in the course of time.

To prevent this action of the water on the disk, we place the core G between the water and the disk *f*, and also cover the other side

of the disk with the same composition, as is shown in broken lines at *h*, and in all cases where paraffine or wax can be used we prefer them, as they are not liable to change; but do not confine ourselves to any particular substance, selecting such material as will not change or melt until the dangerous temperature is reached.

The apparatus thus arranged, with the core *G* between the water and that part of the device in which the solder is to be melted by heat only a few degrees above the highest temperature possible without a fire, is more reliable than when water can come in contact with the part to be so heated, as in the latter case the water must be also heated to the temperature required to melt the solder, and thus the most valuable time, when the fire is small, is lost.

Having thus described our invention, we claim as new and desire to secure by Letters Patent—

1. The disk *f*, secured within the pipe *A* by fusible solder, and covered with paraffine, wax, or their equivalent, substantially as and for the purpose specified.

2. The core *G*, consisting of fusible material, when placed between the water and the disk, secured by solder to be fused by the heat of the fire, substantially as and for the purpose described.

3. The combination of the core *G*, the disk *f*, and the pocket *K* for receiving the core and disk, and allowing a free passage for the water, substantially as herein described.

JOSEPH R. BROWN.
WILLIAM A. FOSKETT.

Witnesses:

JOHN F. BISHOP,
B. H. JOHNSON.