

F. MUELLER & G. W. GWINN.
 CAPPING MACHINE.
 APPLICATION FILED JAN. 14, 1905.

954,200.

Patented Apr. 5, 1910.

3 SHEETS—SHEET 1.

Fig. 2.

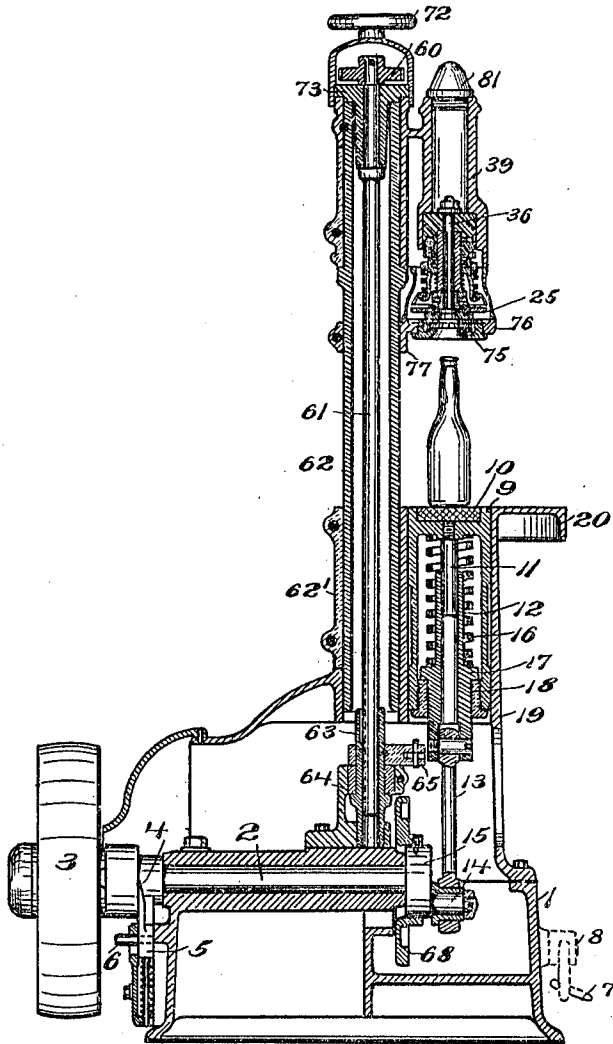
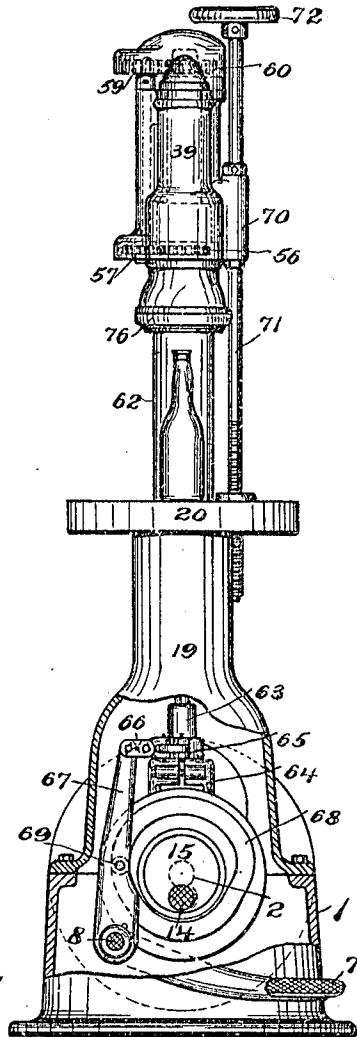

Fig. 1.



Attest
A. White
J. F. Graves.

Inventors
Felix Mueller
George H. Gwinn
 by *Philipp. Sawyer, Rice & Kennedy*
Attys

F. MUELLER & G. W. GWINN.
 CAPPING MACHINE.
 APPLICATION FILED JAN. 14, 1905.

954,200.

Patented Apr. 5, 1910.
 3 SHEETS—SHEET 3.

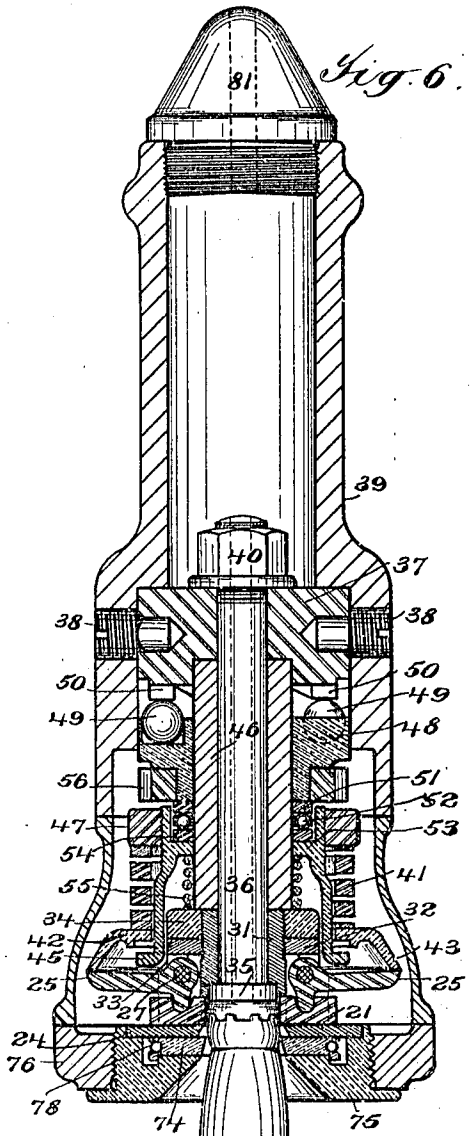
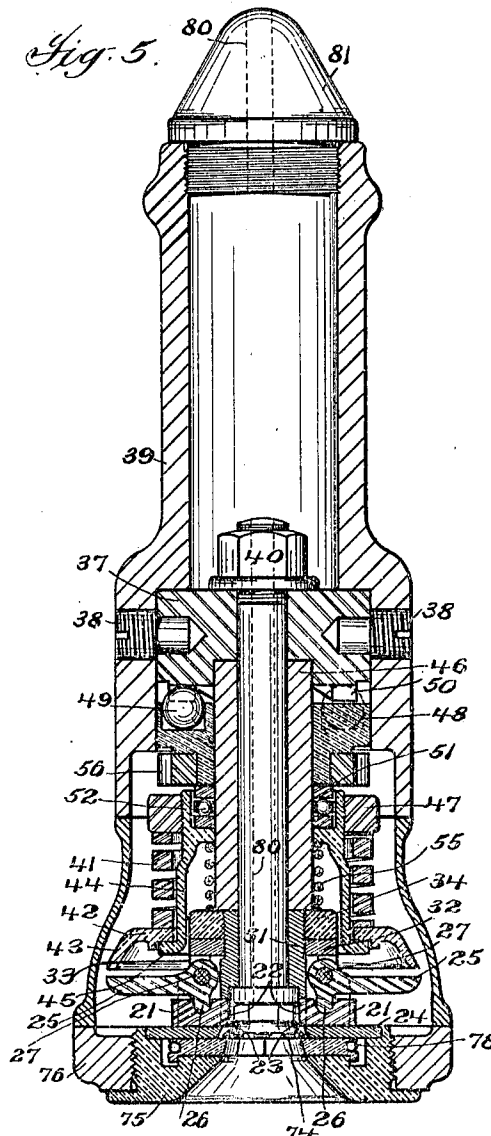

Attest
A. White
J. A. Brown

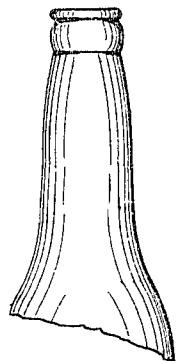

Inventors
Philip Mueller
George H. Gwinn
 by *Philip S. Sawyer, Ricc. Kennedy*
Attys.

F. MUELLER & G. W. GWINN.
 CAPPING MACHINE.
 APPLICATION FILED JAN. 14, 1905.

954,200.

Patented Apr. 5, 1910.

3 SHEETS—SHEET 2.

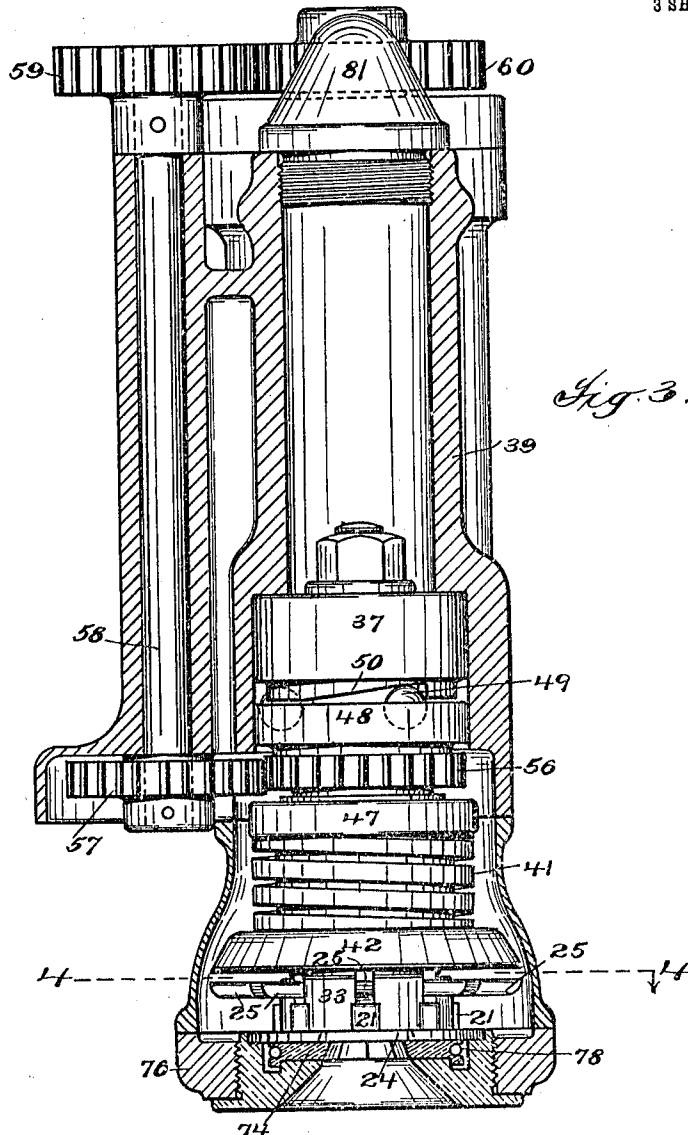

Fig. 3.

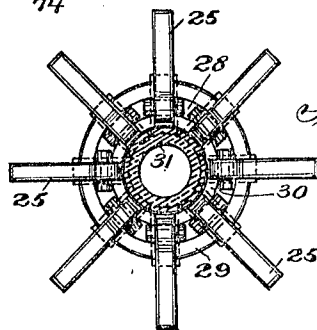

Fig. 4.

Attest
A. White
J. A. Graves.

Inventors
Felix Mueller
George W. Gwinn
by Philipp S. Sawyer, Ric. Kennedy
Attys

UNITED STATES PATENT OFFICE.

FELIX MUELLER AND GEORGE W. GWINN, OF NEW YORK, N. Y., ASSIGNORS TO STANDARD STOPPER COMPANY, OF NEW YORK, N. Y., A CORPORATION OF NEW JERSEY.

CAPPING-MACHINE.

954,200.

Specification of Letters Patent.

Patented Apr. 5, 1910.

Application filed January 14, 1905. Serial No. 241,136.

To all whom it may concern:

Be it known that we, FELIX MUELLER, a subject of the German Emperor, and GEORGE W. GWINN, a citizen of the United States, and both residents of the city, county, and State of New York, have invented certain new and useful Improvements in Capping-Machines, fully described and represented in the following specification and the accompanying drawings, forming a part of the same.

This invention relates to certain improvements in capping machines.

In attaching caps to receptacles, and more particularly to receptacles of earthenware and glass, it is desirable that the capping die shall be constructed so as to allow for variations in the size of the mouth of the receptacles to which the caps are to be attached and variations in the shape of the mouth of said receptacles, since it often happens that glass receptacles intended to be uniform in size will vary considerably and will also be irregular in outline even when made with the same tools.

Machines have been heretofore employed for capping bottles in which the capping die was conical in form, the bottle carrying the cap being caused, in the operation of the machine, to enter the cone shaped recess in the die, the theory of the operation of these machines being that the bottles will enter the die different distances according as the diameter of the mouths of the bottles varies. In the practical operation of these machines, however, it is difficult to regulate with exactness the distance which bottles having different sized necks shall enter the die, and it happens, therefore, that in the use of these machines bottles are frequently broken. Furthermore, every point in the walls of the cone lying in a plane at right angles to its axis is equally distant from that axis, so that when a bottle having an irregular mouth is introduced into the die, it happens that greater pressure will necessarily be brought on some parts of the bottle than on others, this variation in pressure at different points around the mouth of the bottle also tending to break the bottle.

A construction has been suggested in which the cone-shaped die is formed of sections, the sections being held together by a flexible band, the theory of this construction being that the flexible band will permit

the die members to shift somewhat so as to take care of the irregularities which occur in bottles. This construction, permits, however, only of a very limited degree of movement of the parts of the die, is open to the objection that it is difficult to control the distance which bottles having different diameters of mouths shall enter the die, and has not gone into practical use. Other forms of capping dies have been employed, the dies being constructed of sections which move inward after the article to be capped has come within the range of action of the sections to force the flange of the cap to be applied beneath the shoulder on the receptacle. With these constructions, however, the movement of the sections has been produced by a mechanism which is positive in its action, so that variations in the diameters of the mouths of the receptacles to be capped are not automatically compensated for.

The present invention has for one of its objects to produce a capping mechanism employing a die made up of sections in which a movement of the sections, which will increase the area inclosed by the operating faces of the die, is permitted during the capping operation.

A further object of the invention is to produce a capping mechanism which employs a capping die made up of a plurality of sections which are permitted to have a movement during the capping operation to compensate for irregularities or variations in the diameter of the mouths of the articles to be capped, and in which releasing means is employed for positively releasing the die sections after a capping operation is completed, so as to permit the capped article to be readily withdrawn.

A further object of the invention is to produce an improved capping die for use in capping mechanisms which shall be provided with means by which the die can be readily cleared in case the throat formed by the die sections becomes choked.

A further object of the invention is to produce a simple and efficient capping mechanism which shall be cheap to construct and which may be readily operated by unskilled labor.

With these and other objects not specifically referred to in view, the invention consists in certain constructions and in certain

parts, improvements and combinations as will be hereinafter fully described and then specifically pointed out in the claims hereunto appended.

5 Referring to the drawings—Figure 1 represents in front elevation a form of capping mechanism embodying the invention, certain parts being shown in section. Fig. 2 is a vertical central section of the construction shown in Fig. 1. Fig. 3 is an elevation on an enlarged scale, of the capping head construction illustrated in Figs. 1 and 2, the casing inclosing said capping head being shown in section. Fig. 4 is a section on the line 4—4 of Fig. 3. Fig. 5 is a vertical section of the construction shown in Fig. 3, and Fig. 6 is a section similar to Fig. 5, but showing the parts in a different position.

20 Referring to the drawings which illustrate one embodiment of the invention, 1 indicates a base on which the operating parts are mounted, this base being of course varied in its construction and shape according to the particular form of mechanism which 25 may be employed for carrying the invention into effect. In the particular construction shown, the base serves to support a driving shaft 2, said shaft being provided with any suitable driving means, as, for instance, a 30 pulley 3. In the preferred construction and as shown, this pulley will be loosely mounted on the shaft and will be connected thereto by what is known as a single revolution clutch, that is to say, a clutch which permits 35 the shaft when the pulley has been clutched thereto, to make a single revolution, after which the clutch is thrown out, so that the pulley runs loose on the shaft. This single revolution clutch is a well-known mechanical device and any suitable form of it may 40 be employed. Inasmuch, however, as a description of the clutch would in no wise conduce to an understanding of the present invention, specific illustration of the clutch 45 has been omitted, the clutch being simply indicated at 4 and being shown as under the control of a spring pin 5 having mounted thereon an operating pin 6.

50 The means by which the parts of the machine are controlled in their operation may be varied widely and will vary according to the particular type of mechanism employed in carrying out the invention. The operation of the machine illustrated is controlled by a treadle mounted on a rock shaft 8 suitably supported in the base, this rock shaft having an arm, not shown, which operates on the pin 6.

60 In a complete capping machine embodying the invention, means will be provided for supporting the article to be capped, and such a machine will also include mechanism by which a relative movement between the support and the capping die may be effected 65 to bring the article to be capped into the

range of action of the die. While this might be effected by moving either the die or the support, or both, in the construction selected to illustrate the invention, the support alone is moved, the die being stationary. When the invention is embodied in a machine employing a moving support for the receptacle to be capped, the construction of the support and the means for moving it may be of any desired construction. In the 75 construction shown by way of illustration, the support includes a plunger 9, said plunger, in the construction shown, being provided with an elastic pad 10 on which the article to be capped rests. The plunger, in 80 the construction shown, is provided with a stem 11 which enters a guide in a driving head 12, this head being operated from a crank rod 13 which is pivoted to the head and to a crank pin 14 on a crank disk 15, 85 said disk being mounted on the shaft 2. A spring 16 may be introduced between the driver and the plunger, said spring permitting the driver to have, under the influence of the crank mechanism described, a 90 certain degree of upward movement without moving the plunger, the purpose of this construction being, as is well understood in the art, to allow the machine to operate upon receptacles varying in vertical height. 95 The driver is provided with a shoulder 17 which operates against the end of a nut 18 screwed into a plunger, this construction operating to effect a positive downward movement of the plunger after a capping 100 operation has taken place. The plunger and its driving mechanism are shown as incased in a standard 19, the upper end of which is formed to provide a table 20 on which the receptacles to be capped or the 105 ceptacles that have been capped may rest.

The capping die, while it may be varied widely in its details of construction, will comprise a plurality of movable sections or jaws, these sections being marked 21 in the 110 drawings. While the operating faces of these sections may be given any suitable configuration, in the construction shown, these operating faces, which are marked 22, are sections of a cylinder so that the space 115 inclosed thereby is cylindrical in shape, as distinguished from the dies having cone shaped interiors heretofore employed. The edges of these sections at the entrance or mouth of the die may, if desired, be slightly 120 beveled or chamfered off, as indicated at 23, this construction being common in capping dies of various descriptions, its purpose being to prevent any shearing action of the die on the flange of the cap as the cap enters 125 the die.

The die sections will be normally held in operative position, *i. e.*, the cap applying position, and so held as to permit them to expand when necessary in order to increase 130

or vary the position of the sections or the area of the space inclosed by the die, the purpose of this increase in area being to provide for the capping of receptacles having mouths of varying diameters or irregular in contour. The die sections will preferably be guided in their movement, the guide employed being of any suitable construction and varying in construction according to the character of the movement which the die sections have. As shown, the guide includes a plate 24 on which the die sections rest, this plate having an annular opening therein through which the articles to be capped pass into the die, this annular opening being made large enough to permit the entry of the articles having the greatest diameter on which the machine is intended to operate and their caps.

The means referred to by which the sections are held in position and which permit them to expand so as to increase the area inclosed by the operating faces of the die, may be varied widely in construction. As shown, a series of bell-crank levers 25, 26 are employed, there being preferably one of these levers for each of the die sections, and the arms 26 of these levers resting in recesses formed in the sections. In the particular construction shown, these bell-crank levers 25, 26 are pivoted on pins 27 which pins rest in recesses 28 lying between outer ears 29 and inner ears 30, which ears extend from a central block 31. The recesses 28 are formed on a curve, as clearly appears in Fig. 4, and the outer ears 29 are wider than the inner ears 30. The ears 29, 30 extend down to and rest upon the guiding plate 24, and the adjacent ears are cut out, as appears in Fig. 3, so that they form additional guiding means for the jaws 22. The pins are held in position by a plate 32 which has depending lugs 33 which pass down on each side of the tops of the levers 25, 26 and rest upon the pins. This plate is further held in position by a nut 34 which is threaded onto the upper portion of the block 31.

In the preferred construction, an abutment will be provided which operates to limit the distance which the article to be capped can be forced into or through the die sections. While this abutment may be provided in any suitable way, in the construction shown it is formed by a circular plate 35 which is formed on a bolt 36, this bolt passing through and being supported in position by a block or plate 37. This block or plate 37 is supported and held in position by means of screws 38 tapped into the casing 39 in which the capping die mechanism as a whole is contained. The bolt 36 is shown as provided with a nut 40 and this bolt and abutment 35 serve to maintain in position the block 31 in which the levers 25, 26 are mounted.

When levers such as the levers 25, 26 are employed for actuating the die sections, suitable operating means will be provided for these levers, and this means will be of such a character as to permit a rocking movement of the levers on their pivots whenever it is desired that the die sections shall move outward. While these means may be of any suitable character, in the preferred construction, they will embody a spring. In the particular construction illustrated, the spring which operates the lever is marked 41. This spring rests upon an operating plate 42 which has a downward extending flange 43 which overlies the arms 25 of the bell-crank levers 25, 26. The plate 42 may be supported in any desired manner, but in the preferred construction it will be mounted in such a manner as to permit it to be moved toward and away from the levers at proper times to permit the force of the spring at times to be effective on the levers and at other times to permit the levers to be free from the spring. In the construction shown, there is provided a carrier member 44 having an outwardly turned flange 45 on which the plate rests. This carrier member is, as shown, generally tubular in form and is guided in its movement by a filling block 46 which surrounds the bolt 36. The spring 41 will preferably be normally held under tension, this being effected in the particular construction shown by providing a nut 47 which is threaded onto the top of the carrier member 44. The spring rests on the plate 42 which is in turn supported by the outwardly turned flange 45, the upper end of the spring bearing against the nut 47. By adjusting the nut, the tension under which the spring is held may be varied as desired. In the particular construction shown, the bell-crank levers 25, 26 are released from the action of the spring between successive capping operations, the position of the parts between capping operations being indicated in Fig. 5.

When it is desired to operate the capping die to apply a cap to a bottle or other receptacle, the force of the spring is brought to bear upon the die sections through the levers or such other suitable means as may be selected to operate the sections. While the means for bringing the spring into operative relation with respect to the bell-crank levers 25, 26 may be varied widely, in the particular construction shown, there is provided a rotating block 48 having recesses in which are located balls 49. These balls underlie cams 50 which are formed on the underside of the block or plate 37. The rotating block 48 is journaled on the filling block 46 and has a combined rotating and reciprocating movement with respect to this block. The lower edge of the block 48 rests on a washer 51 which washer in turn rests

upon a series of balls 52 which are located in a recess in the upper end of the carrier member 44, the bottom of this recess being formed by a projection 53 extending inwardly from the carrier member. In the construction shown, the balls 52 rest upon a washer 54, the washer resting upon the projection 53. Surrounding the block 46 is a spring 55 said spring bearing at one of its ends against the inwardly extending projection 53 and at its other end against the nut 34. With this construction it is apparent that if the block 48 is rotated, the balls 49 will travel under the cam 50 and force the block 48 downward. This in turn will force the carrier member 44 downward, the plate 42 moving with it. This movement of the plate causes the lower edge of its flange 43 to strike the arms 25 of the bell crank levers 25, 26, and thus to produce a rocking movement of these levers which forces the sections 22 inward to their fullest extent. The parts will preferably be so proportioned that the movement of the block 48 and the carrier member will continue after the die sections have moved inward to their fullest extent, so as to bring the flange 45 of the carrier member below and clear of the plate 42, this position of the parts being clearly indicated in Fig. 6. When the parts are in the position shown in Fig. 6, therefore, the die members will be yieldingly held in position by the action of the spring, and if sufficient force is exerted against the operating faces of the die sections, the die sections will slide outward, the levers 25, 26 rocking in a reverse direction against the tension of the spring as this action takes place.

The tension of the spring 41 will be so calculated as to hold the die sections in place with sufficient force to enable them to bend inward the flange of the cap to be applied by the die, but the force of the spring on the other hand will be so proportioned as to permit an outward movement of the die sections sufficiently to compensate for irregularities and, within the limits, for varying sizes of bottles or other receptacles to be capped.

From the foregoing description, it will be understood that, if a bottle having a mouth of proper size and formed on a circle corresponding with the circle of the flange of the cap be inserted into the die, the cap will be applied without any movement on the part of the sections of the die, this being due to the fact that the sections are normally held in operative position by the mechanism which has just been described. If, however, a bottle having a mouth of the same diameter and of generally circular form, although irregular in form, say, for instance, oval, be pushed up into the die, certain movements of the die sections may take

place according to the shape of the bottle mouth. If, for instance, a bottle having a mouth which is elliptical in shape be pushed up into the die, the minor diameter of the ellipse being equal to the diameter of the circle in which the operative faces of the die sections are normally held, then the die sections at the ends of the major diameter of the ellipse will move outward, while those die sections at the ends of the minor diameter will retain their position. If, again, a bottle the mouth of which is in the shape of a true circle which is greater in diameter than the diameter of the circle in which the operating faces of the die sections lie when they are normally held in capping position, be pushed up into the die, then all the die sections will move outward. It appears, therefore, that in the construction shown, none of the sections may move in the capping operation, all of them may move, or some of them may move, this being determined by the shape of the bottle to be capped. Further, it will be noted that whenever any movement of the die sections takes place, it is always an outward movement, that is, a movement away from the center of the die.

After the capping operation has been completed, the block 48 is given a movement in a reverse direction, the effect of which is to permit the spring 55 which the carrier compressed in its downward movement, to expand, thus carrying the carrier member and the other parts of the device back into their initial position, that is, the position shown in Fig. 5.

The means for rotating the block 48 may be varied widely. As shown, this block carries a gear 56 which gear meshes with a gear 57 on a short vertical shaft 58 supported in the casing of the head. This shaft 58 has on its upper end a gear 59 which is in mesh with a gear 60, this gear being mounted on a long vertical shaft 61 which, in the particular construction shown, is illustrated as being contained in a hollow standard or casing 62 suitably supported in the machine casing. This shaft 61 is stepped in a sleeve 63, the shaft and sleeve being connected by a spline. The sleeve is supported in a bracket 64 and has an arm 65 extending therefrom. This arm 65 is connected by a link 66 to a rock arm 67 loosely mounted on the shaft 8 before referred to. The shaft 2 operates a cam 68 this cam being a closed cam and being shown as mounted on the crank disk 15 before described. The rock arm 67 is provided with a cam roller 69, this construction operating to give the rock arm an oscillating movement. With this construction, it is apparent that each time the clutch is thrown into operation by the treadle 7, the shaft 2 will, through the crank connections pre-

viously described, operate to carry the bottle or other receptacle to be capped, up into the range of action of the die, and the die sections will be operated through the movement of the vertical shaft 61 and the parts connected therewith.

Means may be provided, if desired, to adjust the machine for bottles of different lengths. In the construction shown, this is effected by mounting the casing 39 of the head on the hollow standard or casing 62. This casing is slidingly supported in a long collar 62' which forms a part of the general machine casing. The casing 62 is provided with a tubular projection 70 through which passes a screw 71, this screw being tapped through an opening in the table 20 and being provided with a hand wheel 72. The bearing 73 for the upper end of the shaft 61 is rigidly connected to the hollow casing 62. When, therefore, the hand wheel 72 is turned, the casing 62 and the shaft will be moved vertically in one direction or the other, the splined connection between the shaft 62 and the sleeve 63 permitting this movement.

While the cap to be applied to the receptacle may be supported in any desired manner, or carried on the receptacle itself, in the preferred construction, there will be provided a cap support which is located near the mouth of the throat formed by the operating faces of the die sections. The construction of this cap support may be varied widely. As shown, it consists of a plurality of segmental plates 74, these plates being supported on a nut 75 having a tapered opening therein which registers with the throat and being screwed into a ring 76 which is supported on a bracket 77 mounted on the tubular casing 62. The segmental plates are held in position by means of a spring 78 which surrounds their outer edges. The opening inclosed by the inner edges of the segmental plates is slightly smaller than the greatest diameter of the flange of the cap to be applied. In operating the machine, a cap is forced up through the opening in the segmental plates 74, the spring 78 yielding sufficiently to permit the cap to pass the plates, after which the plates return to their initial position, and the cap rests upon the upper surface of the plates as clearly shown in Fig. 5. The upward movement of the bottle or other receptacle to be capped carries the cap up into the throat and as the cap and bottle or other receptacle pass into the throat, the flange of the cap is bent under the shoulder on the bottle by the operating faces of the die sections. Attention is called to the fact that in the construction described, the bending of the cap flange is completed before the top of the cap strikes the under side of the

abutment 35, the die acting both to draw the cap down into place and to bend the flange of the cap into locking position beneath the shoulder on the receptacle.

It may happen that the operator, after finishing the capping of a series of receptacles, will leave the machine with a cap in place, and when he returns to the machine, will force a second cap into place, so that there will be two caps resting on the cap support instead of one. This may result in seriously clogging the machine. Means are accordingly provided to permit the throat to be cleared whenever it is clogged for this or for any other reason. While these means may be varied, in the construction shown, the abutment 35 has an opening 80 therethrough, this opening extending up through the bolt 36 and also through the cap 81 which is shown as closing the top of the casing 39. With this construction a rammer or other suitable device may be pushed down through the opening to clear the throat from obstruction.

While the construction which has just been described is an exceedingly efficient one for carrying the invention into effect, it is to be understood that the invention may be embodied in constructions which differ widely therefrom. The invention is not, therefore, to be restricted to the specific construction hereinbefore described and illustrated in the accompanying drawings.

What is claimed is:—

1. In a capping die, the combination with a plurality of sections, the acting faces of which form a throat, of means for normally holding the sections in operative position, said means being constructed to permit a movement of the sections during the cap applying operation to vary the position of the acting faces, and means for releasing the holding means after the applying operation is completed, substantially as described.

2. In a capping die, the combination with a plurality of sections, the acting faces of which form a throat, of a cap support located at the mouth of the throat, and means for normally holding the sections in operative position, said means being constructed to permit a movement of the sections during the cap applying operation to vary the position of the acting faces, substantially as described.

3. In a capping die, the combination with a plurality of sections, the acting faces of which form a throat, of a cap support located at the mouth of the throat, means for normally holding the sections in operative position, said means being constructed to permit a movement of the sections during the cap applying operation to vary the position of the acting faces, and means for re-

leasing the holding means after the applying operation is completed, substantially as described.

4. In a capping mechanism, the combination with a capping die having a plurality of sections, the acting faces of which form a throat, of means for holding the sections in operative position, said means being constructed to permit a movement of the sections during the cap applying operation to vary the area inclosed by the acting faces, a support for the receptacle to be capped, means for producing a relative movement between the die and the support for the receptacle, and means for releasing the holding means after the applying operation is completed, substantially as described.

5. In a capping mechanism, the combination with a capping die having a plurality of sections, the acting faces of which form a throat, of a cap support located at the mouth of the throat, means for normally holding the sections in operative position, said means being constructed to permit a movement of the sections during the cap applying operation to vary the position of the acting faces, a support for the receptacle to be capped, and means for producing a relative movement between the die and the support for the receptacle, substantially as described.

6. In a capping mechanism, the combination with a capping die having a plurality of sections, the acting faces of which form a throat, of a cap support located at the mouth of the throat, means for normally holding the sections in operative position, said means being constructed to permit a movement of the sections during the cap applying operation to vary the position of the acting faces, a support for the receptacle to be capped, means for producing a relative movement between the die and the support for the receptacle, and means for releasing the holding means after the applying operation is completed, substantially as described.

7. In a capping die, the combination with a plurality of sections, the acting faces of which form a cylindrical throat, of spring controlled means for normally holding the sections in operative position, said means being constructed to permit a movement of the sections during the cap applying operation to vary the position of the acting faces, and releasing means for the holding means, substantially as described.

8. In a capping mechanism, the combination with a capping die having a plurality of sections, the acting faces of which form a cylindrical throat, of spring controlled means for normally holding the sections in operative position, said means being constructed to permit a movement of the sections during the cap applying operation to

vary the position of the acting faces, a cap support located at the mouth of the throat, a support for the receptacle to be capped, means for producing a relative movement between the capping die and receptacle support, and releasing means for the holding means, substantially as described.

9. In a capping mechanism, the combination with a capping die having a plurality of sections, the acting faces of which form a cylindrical throat, of means for normally holding the sections in operative position, said means being constructed to permit a straight line movement of the sections toward and away from the axis of the die, a support for the receptacle to be capped, and means for producing a relative movement between the die and support, substantially as described.

10. In a capping mechanism, the combination with a capping die having a plurality of sections, the acting faces of which form a cylindrical throat, of a cap support located at the mouth of the throat, means for normally holding the sections in operative position, said means being constructed to permit a straight line movement of the sections toward and away from the axis of the die, a support for the receptacle to be capped, and means for producing a relative movement between the die and support, substantially as described.

11. In a capping mechanism, the combination with a capping die having a plurality of sections, the acting faces of which form a cylindrical throat, of a cap support located at the mouth of the throat, means for normally holding the sections in operative position, said means being constructed to permit a straight line movement of the sections toward and away from the axis of the die, a support for the receptacle to be capped, means for producing a relative movement between the die and support, and releasing means for the holding means, substantially as described.

12. In a capping die, the combination with a plurality of sections, the acting faces of which form a throat, of guiding means for the sections, and means for normally holding the sections in operating position, said means including a spring controlled lever mechanism, whereby the sections are permitted to have a movement during the cap applying operation to vary the position of the acting faces, substantially as described.

13. In a capping die, the combination with a plurality of sections, the acting faces of which form a cylindrical throat, of a cap support located at the mouth of the throat, guiding means for the sections, means for normally holding the sections in operating position, said means including a spring controlled lever mechanism, whereby the sec-

tions are permitted to have a movement during the cap applying operation to vary the position of the acting faces, and releasing means for the holding means, substantially as described.

14. In a capping mechanism, the combination with a die having a plurality of sections, the acting faces of which form a cylindrical throat, of a plurality of levers, one for each section, spring controlled operating means for the levers, and means normally holding the levers and jaws in operative position, releasing means for said operating means, a support for the receptacle to be capped, and means for producing a relative movement between the receptacle support and the die, substantially as described.

15. In a capping die, the combination with a plurality of sections, the acting faces of which form a throat, of a guiding plate for the sections, a plurality of operating levers, one for each section, lever actuating means, a spring for forcing the actuating means into operative relation with the levers, and releasing means for rendering the spring inoperative, substantially as described.

16. In a capping mechanism, the combination with a capping die having a plurality of sections, the acting faces of which form a cylindrical throat, of a guiding plate for the sections, a plurality of operating levers, one for each section, lever actuating means, a spring for forcing the actuating means into operative relation with the levers, releasing means for rendering the spring inoperative, a support for the receptacle to be capped, and means for producing a relative movement between the support and the die, substantially as described.

17. In a capping die, the combination with a plurality of sections, the acting faces of which form a throat, of means for holding the sections in operative position, said means including a spring normally held under tension, means for increasing the tension of the spring, and releasing means for the holding means, substantially as described.

18. In a capping die, the combination with a plurality of sections, the acting faces of which form a cylindrical throat, of a plurality of operating levers, actuating means for the levers, said means including a spring normally held under tension, means for increasing the tension of the spring, and releasing means, substantially as described.

19. In a capping mechanism, the combination with a capping die having a plurality of sections, the acting faces of which form a cylindrical throat, of a plurality of operating levers, actuating devices for the levers, said devices including a spring normally held under tension, means for increasing the tension of the spring, releasing means, a support for the receptacle to be

capped, and means for producing a relative movement between the support and the die, substantially as described.

20. The combination with a capping mechanism, of a capping die having a plurality of sections, the acting faces of which form a cylindrical throat, operating levers for the sections, lever actuating means including a spring, a rotating cam for increasing the tension of the spring, releasing means, a support for the receptacle to be capped, and means for producing a relative movement between the support and the die, substantially as described.

21. The combination with a capping mechanism, of a capping die provided with a plurality of sections, the acting faces of which form a cylindrical throat, actuating levers for the sections, a spring for positioning the levers, an actuating cam for increasing the tension of the spring, a retractor for freeing the levers from the action of the spring, a support for the receptacle to be capped, and means for producing a relative movement between the support and the die, substantially as described.

22. The combination with a capping mechanism, of a capping die provided with a plurality of sections, the acting faces of which form a cylindrical throat, a cap support at the mouth of the throat, actuating levers for the sections, a spring for positioning the levers, an actuating cam for increasing the tension of the spring, a retractor for freeing the levers from the action of the spring, a support for the receptacle to be capped, and means for producing a relative movement between the support and the die, substantially as described.

23. In a capping mechanism, the combination with a capping die having a plurality of sections, the acting faces of which are arranged to form a throat, of guiding means for the sections, means for holding the sections in operative position, said means permitting a movement of the sections away from the axis of the die in order to vary the position of the sections, a support for the receptacle to be capped, means for producing a relative movement between the die and the support, and a stationary abutment operating to determine the distance which the article to be capped shall enter the die, substantially as described.

24. In a capping mechanism, the combination with a capping die having a plurality of sections, the acting faces of which are arranged to form a throat, of guiding means for the sections, means for holding the sections in operative position, said means permitting a movement of the sections away from the axis of the die in order to increase the area inclosed by the sections, a support for the receptacle to be capped, means for producing a relative movement between the

die and the support, and a stationary abutment operating to determine the distance which the article to be capped shall enter the die, said abutment having a perforation 5 through which a clearing tool may be inserted, substantially as described.

25. In a capping mechanism, the combination with a capping die having a plurality of sections, the acting faces of which are 10 arranged to form a throat, of guiding means for the sections, means for holding the sections in operative position, said means permitting a movement of the sections away from the axis of the die in order to increase 15 the area inclosed by the sections, a support for the receptacle to be capped, means for producing a relative movement between the die and the support, a stationary abutment 20 operating to determine the distance which the articles to be capped shall enter the die, said abutment having a perforation through which a clearing tool may be inserted, and releasing means for the die sections, substantially as described.

26. In a capping mechanism, the combination with a capping die having a plurality of sections, the acting faces of which are 25 arranged to form a throat, of a cap support located at the mouth of the throat, guiding means for the sections, means for holding the sections in operative position, said means permitting a movement of the 30 sections away from the axis of the die in order to increase the area inclosed by the sections, a support for the receptacle to be capped, means for producing a relative 35 movement between the die and the support, and a stationary abutment operating to determine the distance which the articles to be capped shall enter the die, substantially 40 as described.

27. In a capping mechanism, the combination with a capping die having a plurality of sections, the acting faces of which are 45 arranged to form a throat, of a cap support located at the mouth of the throat, guiding means for the sections, means for holding the sections in operative position, said means permitting a movement of the sections away 50 from the axis of the die in order to increase the area inclosed by the sections, a support for the receptacle to be capped, means for

producing a relative movement between the die and the support, a stationary abutment 55 operating to determine the distance which the articles to be capped shall enter the die, and releasing means for the die sections, substantially as described.

28. In a capping mechanism, the combination with a capping die having a plurality 60 of sections, the acting faces of which are arranged to form a throat, of a cap support located at the mouth of the throat, guiding means for the sections, means for holding the sections in operative position, said means 65 permitting a movement of the sections away from the axis of the die in order to increase the area inclosed by the sections, a support for the receptacle to be capped, means for producing a relative movement between the 70 die and the support, and a stationary abutment operating to determine the distance which the articles to be capped shall enter the die, said abutment having a perforation through which a clearing tool may be inserted, 75 substantially as described.

29. In a capping mechanism, the combination with a capping die having a plurality of sections, the acting faces of which are 80 arranged to form a throat, of a cap support located at the mouth of the throat, guiding means for the sections, means for holding the sections in operative position, said means permitting a movement of the sections away 85 from the axis of the die in order to increase the area inclosed by the sections, a support for the receptacle to be capped, means for producing a relative movement between the die and the support, a stationary abutment 90 operating to determine the distance which the articles to be capped shall enter the die, said abutment having a perforation through which a clearing tool may be inserted, and releasing means for the die sections, substantially 95 as described.

In testimony whereof, we have hereunto set our hands in the presence of two subscribing witnesses.

FELIX MUELLER.
GEORGE W. GWINN.

Witnesses:

J. A. GRAVES,
A. WHITE.