



(10) **DE 601 43 893 C5** 2013.07.11

(12) **Geänderte Patentschrift**

Europäische Veröffentlichungsnummer
(97) **EP 1 308 002 B1**
(21) Deutsches Aktenzeichen: **601 43 893.0**
(96) Europäisches Aktenzeichen: **01 95 5821.2**
(96) Europäischer Anmeldetag: **12.07.2001**
(97) Erstveröffentlichung durch das EPA: **07.05.2003**
(97) Veröffentlichungstag
der Patenterteilung beim EPA: **19.01.2011**
(45) Veröffentlichungstag
des geänderten Patents im Patentblatt: **11.07.2013**

(51) Int Cl.: **H04L 12/28** (2006.01)
H04L 29/08 (2006.01)

Patent im Beschränkungsverfahren geändert

<p>(30) Unionspriorität: 217997 P 13.07.2000 US 690213 17.10.2000 US</p>	<p>(84) Benannte Vertragsstaaten: AT, BE, CH, CY, DE, DK, ES, FI, FR, GB, GR, IE, IT, LI, LU, MC, NL, PT, SE, TR</p>
<p>(73) Patentinhaber: Aeritas LLC, Dallas, Tex., US</p>	<p>(72) Erfinder: MAMDANI, Malik, Dallas, TX 75219, US; GRANT, Curtis, Flower Mound, TX 75028, US; JOHNSON, Patrick, Trophy Club, TX 76262, US; BOMAR, Kevin, Weatherford, TX 76087, US; WHATLEY, Tim, Irving, TX 75063, US</p>
<p>(74) Vertreter: BOEHMERT & BOEHMERT, 80336, München, DE</p>	

(54) Bezeichnung: **VERFAHREN UND SYSTEM ZUR ERLEICHTERUNG VON DRAHTLOSEN ELEKTRONISCHEN HANDEL-TRANSAKTIONEN**

(57) Hauptanspruch: A method for facilitating a transaction using a wireless network, comprising:
receiving a transaction request at a transaction management system for a user selected transaction, said transaction request being received from an Internet-enabled wireless telephone (308) of the user;
in response to the received transaction request, generating an optically scannable transaction code at the transaction management system;
communicating the optically scannable transaction code to the wireless telephone (308), the optically scannable transaction code being displayed on a visual display (308d) of the wireless telephone (308), the displayed optically scannable transaction code being scanned by a transaction fulfillment system for authorising fulfillment of the user selected transaction in response to the optically scannable transaction code being optically scanned; and
verifying fulfillment of the transaction.

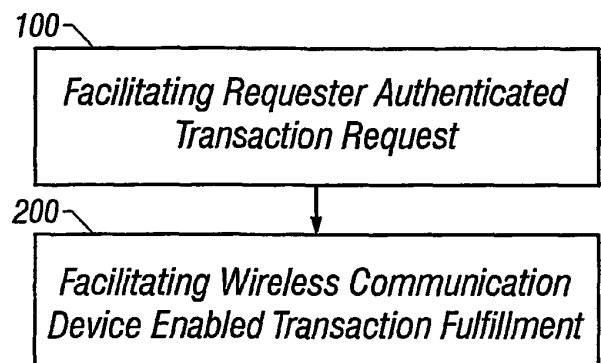

Beschreibung

Background

[0001] The disclosures herein relate generally to mobile electronic commerce, and more particularly to methods and systems for facilitation of wireless e-commerce transactions.

[0002] Mobile e-commerce is expected to grow at a tremendous rate. The sheer scale of the opportunity is impressive. The number of Internet-enabled mobile devices is expected to exceed the number of PCs by 2003. It is predicted that by 2004 the majority of e-commerce purchases will be made through wireless communication devices.

[0003] With the convergence of location information and wireless access to the Internet, users of wireless communication devices will be able to receive product offerings relevant to their location and interests. This will open up a whole new method for targeting customers with advertising. A key area of interest in wireless e-commerce is the communication of targeted ads to the wireless devices. However, to take full advantage of wireless e-commerce, users will need to be in a position to act on such advertisements in a real time manner. This will require that transactions to be made using a wireless communication device in concert with receiving an advertisement for a product or service.

[0004] There are several barriers, however, that must be overcome to make such wireless e-commerce transactions commonplace. One such barrier to wireless transactions being widely accepted is security. For wireless transactions to be embraced, systems must be in place for preventing unauthorized purchases on a user's wireless account. Such security measures are even more important in the case of a wireless communication device, due to situations such as the wireless communication device being lost or stolen. Because wireless communication devices are significantly less secure than non-portable communication devices, steps must be taken to provide an elevated degree of security.

[0005] However, present e-commerce security solutions are limited in their ability to provide effective and efficient solutions for facilitating secured wireless e-commerce transactions.

[0006] Another barrier that must be overcome to make wireless e-commerce transactions commonplace is tying e-commerce transactions to "real world" products and services. For example, if an authorized user of a wireless communication device purchases a movie ticket for a show at a particular theater using her wireless communication device, systems must be in place for notifying the theater that the ticket has

been purchased by an authorized user. Furthermore, systems must be in place for permitting the authorized user of the wireless communication device to obtain entry to the theater and the show once at the theater.

[0007] Present solutions for tying e-commerce transactions to real world products are inconvenient and time-consuming. As a result, they offset much of the convenience of facilitating a wireless e-commerce transaction. For example, one present solution for tying an e-commerce transaction to a corresponding real world product requires that a printed confirmation, such as a receipt, pass or ticket, be printed out on a printer. Such a solution requires that the printed confirmation be generated at a physical location. The printed confirmations often include non-standardized barcodes that are processed at the merchant's location. Typically, the printed confirmation needs to be generated at a location different than the location where the wireless e-commerce transaction is performed.

[0008] Accordingly, what is needed is a method for enabling wireless e-commerce transactions to be facilitated and fulfilled in a secure and convenient manner.

[0009] With reference to document GB 2362012A, the applicant has voluntarily limited the scope of the present application, and submitted separate claims for GB.

[0010] Document WO 01/82031 A2 discloses a system including at least one portable device capable of presenting the user with portable device applications and content which can be displayed to the user in the form of a bar code or other type of code on the screen of the device to be read or scanned.

[0011] Methods for redeeming coupons in a supermarket by means of a barcode scanner are known from US 5,789,732 and WO 00/03328.

[0012] A method for checking a user identity in which a code generation device sends generated codes to a mobile phone upon request is known from prior right DE 100 05 487 A1.

Summary

[0013] According to one aspect of the present invention, there is provided a method of facilitating a transaction using a wireless network, comprising: receiving a transaction request at a transaction management system for a user selected transaction, said transaction request being received from an Internet-enabled wireless telephone of the user; in response to the received transaction request, generating an optically scannable transaction code at the transaction management system;

communicating the optically scannable transaction code to the wireless telephone, the optically scannable transaction code being displayed on a visual display of the wireless telephone, the displayed optically scannable transaction code being scanned by a transaction fulfillment system for authorising fulfillment of the user selected transaction in response to the optically scannable transaction code being optically scanned; and verifying fulfillment of the transaction.

[0014] According to another aspect of the present invention, there is provided a transaction apparatus for facilitating a transaction using a wireless network capable of:

receiving a transaction request for a user selected transaction from an Internet-enabled wireless telephone of the user;

in response to the received transaction request, generating an optically scannable transaction code at a transaction management system;

communicating the optically scannable transaction code to the wireless telephone, the optically scannable transaction code being adapted to be displayed on a visual display of the wireless telephone, the displayed optically scannable transaction code being adapted to be scanned by a transaction fulfillment system for authorising fulfillment of the user selected transaction in response to the optically scannable transaction code being optically scanned; and verifying fulfillment of the transaction.

[0015] In the claim version for GB, the method and the apparatus additionally comprises a second optically scannable transaction code being transmitted to the wireless communications device in response to fulfillment of the transaction.

Brief Description of the Drawings

[0016] [Fig. 1](#) is a flowchart illustrating an embodiment of a method for facilitating a wireless transaction.

[0017] [Fig. 2](#) is a flowchart illustrating an embodiment of a method for facilitating authentication of a spoken authentication code of a transaction requester.

[0018] [Fig. 3A](#) is a flow chart illustrating an embodiment of a method for facilitating fulfillment of a wireless transaction, wherein transaction code verification is completed by a transaction management system.

[0019] [Fig. 3B](#) is a flow chart illustrating an embodiment of a method for facilitating fulfillment of a wireless transaction, wherein transaction code verification is completed by a transaction fulfillment system.

[0020] [Fig. 4](#) is a block diagram illustrating an embodiment of a system for facilitating a wireless transaction using a telephonic-type wireless communication device.

[0021] [Fig. 5](#) is a diagrammatic view illustrating an embodiment of a telephonic-type wireless communication device.

[0022] [Fig. 6](#) is a block diagram illustrating an embodiment of operations for carrying out a wireless transaction using the system illustrated in [Fig. 4](#).

[0023] [Fig. 7](#) is a block diagram illustrating an embodiment of a system for facilitating fulfillment of a wireless transaction using a non-telephonic type wireless communication device.

[0024] [Fig. 8](#) is a diagrammatic view illustrating an embodiment of a non-telephonic type wireless communication device.

[0025] [Fig. 9](#) is a block diagram illustrating an embodiment of operations for carrying out a wireless transaction using the system illustrated in [Fig. 7](#).

[0026] [Fig. 10](#) is a block diagram illustrating another embodiment of operations for carrying out a wireless transaction using the system illustrated in [Fig. 7](#).

Detailed Description

[0027] An embodiment of a method for facilitating a wireless transaction is illustrated in [Fig. 1](#). At a box **100**, the method includes an operation of facilitating a requester authenticated transaction request. At a box **200**, the method includes an operation of facilitating wireless communication device enabled transaction fulfillment.

[0028] By wireless transaction, it is meant that the transaction is requested and fulfilled through the use of a wireless communication device. By wireless communication device enabled transaction fulfillment, it is meant that the wireless communication device is used for facilitating fulfillment of the actual products or services requested. Internet enabled wireless telephones, Internet enabled wireless personal digital assistants (wPDA's) and wireless enabled laptop computers illustrate examples of suitable wireless communication devices capable of connecting with and communicating through a computer network system, such as the Internet. Broadly speaking, the wireless communication devices discussed herein are wireless communication devices capable of accessing a public computer network, a private computer network or both.

[0029] As described below in greater detail, an apparatus for facilitating the methods and operations dis-

closed herein may include functional systems, such as a transaction management system and a transaction fulfillment system. The transaction requester utilizes a wireless communication device for communicating information to and from the transaction management system and the transaction fulfillment system.

[0030] Two or more of the functional systems of the apparatus, such as the transaction management system and the transaction fulfillment system, may be located at a remote location from each other. However, in some applications, it may be advantageous for the functional systems to be located at the same physical location. In these applications, it may also be advantageous for a single integrated hardware system comprising the transaction management system and the transaction fulfillment system.

[0031] The portability of wireless communication devices requires that sufficient security measures be in place to insure that the transaction requester is an authorized user of the wireless communication device. The intent of such security measures is to insure that an unauthorized user of the wireless communication device cannot facilitate a transaction using the wireless communication device. Accordingly, it is advantageous that the method for facilitating the wireless transaction includes an operation for verifying that the transaction requester is an authorized user of the wireless communication device.

[0032] An embodiment of a method for performing the operation of facilitating the requester authenticated transaction request, the box **100** in [Fig. 1](#), is illustrated in [Fig. 2](#). At a box **102**, the method includes receiving, at the transaction management system, a transaction request from a wired or a wireless communication device of a transaction requester. At a box **104**, the identity of the transaction requester is authenticated. At a box **106**, a first transaction barcode (FTB) is communicated to the wireless communication device. Depending on the configuration of the system architecture employed for carrying out the method **100**, the FTB may be communicated from the transaction management system or the transaction fulfillment system.

[0033] The FTB illustrates a first example of an optically scannable transaction code used to facilitate fulfillment of the transaction request. In subsequent operations disclosed herein, the FTB is displayed on a visual display of the wireless communication device for being optically scanned by a component of the transaction fulfillment system for enabling full or partial fulfillment of the transaction request.

[0034] Voice authentication illustrates one example of a suitable technique for performing the operation of verifying the identity of the transaction requester at the box **104**. A method for performing the operation of

voice authentication of the transaction requester includes receiving, at a box **104a**, a spoken transaction requester authentication code. It is contemplated that the spoken authentication code can be received from a wired telephone or the wireless communication device. At a box **104b**, an operation of comparing the spoken transaction requester authentication code is performed. At a box **104c**, an operation is performed for determining a match between the spoken transaction requester authentication code and an authentic voice print for an authorized user of the wireless communication device.

[0035] An example of voice authentication includes the user of a wireless phone calling into a secure server and speaking their phone number. The spoken telephone number illustrates an example of the spoken transaction requester authentication code. The spoken telephone number is then compared to an authentic voice print of an authorized user of the wireless communication device. If the spoken transaction requester authentication code matches the authentic voice print, the transaction requester is permitted to continue with fulfillment of the transaction.

[0036] An embodiment of a method for performing the operation of facilitating wireless communication device enabled transaction fulfillment, the box **200** in [Fig. 1](#), is illustrated in [Fig. 3A](#). The method for the embodiment illustrated in [Fig. 3A](#) is best suited for being facilitated by a system in which verification of transaction codes is performed at the transaction management system. At a box **201**, the FTB is received by the wireless communication device. At a box **202**, the FTB is scanned from the wireless communication device. At a box **204**, the FTB is verified. Verifying the FTB includes decoding the scanned FTB at a box **204a**, communicating the decoded FTB to the transaction management system at a box **204b** and correlating the decoded FTB to a first transaction fulfillment event at a box **204c**. At a box **206**, the first transaction fulfillment event is performed.

[0037] At a box **208**, a second transaction barcode (STB) is received by the wireless communication device. At a box **210**, the STB is scanned from the wireless communication device. At a box **212**, the STB is verified. Verifying the STB includes decoding the scanned STB at a box **212a**, communicating the decoded STB to the transaction management system at a box **212b** and correlating the decoded STB to a first transaction fulfillment event at a box **212c**. At a box **214**, the second transaction fulfillment event is performed.

[0038] The first and second fulfillment events may be physical events or informational events. Activating a turnstile at a movie theater illustrates an example of a physical event. Communicating directions to a hotel illustrates an example of an informational event.

[0039] Another embodiment of a method for performing the operation of facilitating wireless communication device enabled transaction fulfillment, the box **200** in **Fig. 1**, is illustrated in **Fig. 3B**. The method illustrated in **Fig. 3B** is best suited for being facilitated by a system in which verification of transaction codes is performed at the transaction fulfillment system. At a box **201'**, the FTB is received by the wireless communication device. At a box **202'**, the FTB is scanned from the wireless communication device. At a box **204'**, the FTB is verified. Verifying the FTB includes decoding the scanned FTB at a box **204a'**, correlating the decoded FTB to a first transaction fulfillment event at a box **204b'** and communicating a first fulfillment verification (FFV) to the transaction management system at a box **204c**. Fulfillment verifications may be used by the transaction management system for coordinating operations, such as removing the requested transaction from a list of available transactions. At a box **206**, the first transaction fulfillment event is performed.

[0040] At a box **208'**, a second transaction barcode (STB) is received by the wireless communication device. At a box **210'**, the STB is scanned from the wireless communication device. At a box **212**, the STB is verified. Verifying the STB includes decoding the scanned STB at a box **212a'**, correlating the decoded STB to a first transaction fulfillment event at a box **212b'** and communicating a second fulfillment verification (SFV) to the transaction management system at a box **212c'**. At a box **214'**, the second transaction fulfillment event is performed.

[0041] An embodiment of a transaction apparatus **300** for carrying out the methods of **Fig. 1–Fig. 3B** using a telephonic type wireless communication device is illustrated in **Fig. 4**. The transaction apparatus **300** includes a transaction management system **302** coupled to a transaction fulfillment system **304** and an client system **305**. It is also contemplated that in some applications it may be advantageous for the client computer system to be omitted from or discrete from the transaction apparatus **300**. The transaction management system **302** is coupled to the transaction fulfillment system **304** through a computer network system **306**. A wireless communication device **308** is coupled to the transaction management system **302** and to the transaction fulfillment system **304** through a telecommunications network system **310**. A transaction requester **312** utilizes the wireless communication device **308** for communicating with the transaction management system **302** and the transaction fulfillment system **304**.

[0042] A transport control protocol/Internet protocol (TCP/IP) computer network system illustrates an example of the computer network system **306**. A suitable TCP/IP computer network system is a global computer network such as the Internet.

[0043] The telecommunications network system **310** includes a wireless telecommunications network and a wired telecommunications network. The telecommunication network system **310** enables communication of voice and data information to and from the transaction management system **302** and the transaction fulfillment system **304**. The telecommunications networks of Sprint, AT&T, and Southwestern Bell illustrate examples of the telecommunication network system **310**.

[0044] The transaction management system **302** includes a central processing unit (CPU) **302a**, an information storage device **302b**, a network interface system **302c**, speech services module **302d** and barcode software **302e**. A network server or a workstation comprise the CPU **302a**. A Dell PowerEdge™ series server illustrates an example of a suitable commercially available network server. A Dell Precision™ series workstation illustrates an example of a suitable commercially available workstation.

[0045] The information storage device **302b**, such as a disk drive, is coupled to the CPU **302a** for storing information in non-volatile memory. A Dell PowerVault (TM) series storage device illustrates an example of a suitable information storage device **302b**. Fulfillment information, barcode information and authentic voice prints illustrate examples of information retrieved from the information storage device **302b**.

[0046] The network interface system **302c** is coupled to the CPU **302a** for facilitating the communication of information between the transaction management system **302**, the computer network system **306** and the wireless communication device **308**. A suitable network interface system includes a router such as, for example, a Cisco Systems 7200 series unit coupled to a data service unit/channel service unit (hereinafter referred to as a DSU/CSU) such as, for example, an ADC Kentrox D-Serv (TM) series unit.

[0047] The speech services module **302d** enables communication of voice signals between the wireless communication device **308** and the transaction management system **302**. The speech services module **302d** includes components such as hardware and software for enabling voice authentication.

[0048] Voice authentication is a desirable technique for verifying the identity of the transaction requester. Wireless communication devices are not well suited for entering alpha information. Spoken authentication codes can be effectively and conveniently communicated from a wireless communication device such as a wireless telephone. Accordingly, the use of voice authentication reduces the difficulty in submitting identity verification information.

[0049] Voice authentication technologies are commercially available from a number of sources. One example of a suitable voice authentication is Nuance Verifier 2.0 offered by Nuance Communications. Nuance Verifier is tightly integrated with Nuance 7.0 speech recognition software to ensure an exceptional level of user convenience and security. Users are recognized and authenticated simultaneously, shortening overall call duration, and eliminating the need for users to remember personal identification numbers and passwords.

[0050] The tight integration of voice authentication and speech recognition technologies enables Nuance Verifier 2.0 to take advantage of unique distributed architecture associated with the Nuance platform. This architecture supports simultaneous load balancing of speech recognition, natural language understanding, voice authentication, and text-to-speech resources. It ensures optimal usage of every server CPU in the network, thus minimizing the amount of hardware required, and the associated cost, for a given speech system.

[0051] SpeakEZ™ voice print speaker verification software offered by T-Netix Incorporated illustrates another example of voice authentication software. Smart Tone Technologies Incorporated offers proprietary software for enabling positive voice identification over wired and cellular telephones and in Internet applications. Both of these software offerings illustrate additional examples of voice authentication software that may be incorporated into the speech services module **302d**.

[0052] The SpeakEZ voice print speaker verification functionality has been incorporated into a number of commercially available software development tool kits and interactive voice response (IVR) systems. These types of development tool kits and IVR systems are suitable for providing the transaction management system **302** with voice authentication functionality. Examples of commercially available software development tool kits and IVR systems incorporating SpeakEZ voice print speaker verification include the following. BioNetrix has integrated SpeakEZ voice print speaker verification into its Bio-Netrix Authentication Suite. Envoy Incorporated has integrated SpeakEZ voice print speaker verification into a number of its computer telephony development tool kits. IBM has integrated SpeakEZ voice print speaker verification into its DirectTalk/6000 and DirectTalk/2 IVR systems. Periphonics Corporation has integrated SpeakEZ voice print speaker verification into its VPS family of IVR systems.

[0053] The barcode software **302e** enables encoding and decoding of barcodes. The barcode software **302e** is accessible by the CPU **302a** from a computer readable medium, such as a compact disk,

disk drive or network connection. Commercially available barcode software from Omniplanar Incorporated, Peernet Incorporated and RVB Systems Group illustrate examples of the barcode software **302e**.

[0054] The transaction fulfillment system **304** includes a central processing unit (CPU) **304a**, an information storage device **304b**, a network interface system **304c**, a barcode reader **304d**, and barcode software **304e**. A network server or a workstation comprise the CPU **304a**. A Dell PowerEdge™ series server illustrates an example of a suitable commercially available network server. A Dell Precision™ series workstation illustrates an example of a suitable commercially available workstation.

[0055] The information storage device **304b**, such as a disk drive unit, is coupled to the CPU **304a** for storing information in non-volatile memory. A Dell PowerVault (TM) series storage device is an example of a suitable information storage device **304b**. Fulfillment reply information, product information, and barcode information illustrate examples of information that may be retrieved from the information storage device **304b**.

[0056] The network interface system **304c** is coupled to the CPU **304a** for facilitating the communication of information between the transaction fulfillment system **304**, the computer network system **306** and the wireless communication device **308**. A router such as, for example, a Cisco Systems 7200 series unit coupled to a data service unit/channel service unit (hereinafter referred to as a DSU/CSU) such as, for example, an ADC Kentrox D-Serv (TM) series unit illustrates an example of the network interface system **304c**.

[0057] Depending on the volume of transaction requests fulfilled through the transaction fulfillment system **304**, a network interface card ("NIC") and a modem illustrate two other examples of suitable network interface system **304c**.

[0058] The bar code reader **304d** enables transaction codes, such as barcodes, to be optically scanned and decoded. The barcode reader **304d** is coupled to the CPU **304a** for communicating a scanned representation of a barcode to the CPU **304a**. Several commercially available barcodes are offered by Metrologic Incorporated. Metrologic offers a Fixed-mount Scanner under the model no. S700I and an in-counter scanner under the model no. MS860.

[0059] The barcode software **302e** enables encoding and decoding of barcodes. The barcode software **302e** is accessible by the CPU **302a** from a computer readable medium, such as a compact disk, disk drive or network connection. Barcode software that is commercially available from Omniplanar Incorporated

rated, Peernet Incorporated and RVB Systems Group illustrate examples of the barcode software **302e**.

[0060] The client computer system **305** is the system of the entity that offers the product or service requested in the transaction request. The client computer system **305** communicates with the transaction management system **302** and the transaction fulfillment system **304** to facilitate the transaction. The client system **305** includes a network interface a CPU **305a**, an information storage device **305b** and a network interface device **305c**. The CPU **305a** is coupled to the information storage device **305b** for storing information, such as product and service information, in non-volatile memory. The network interface device **305c** is coupled between the CPU **305a** and the computer network system **306** for enabling communication therebetween.

[0061] The wireless communication device **308** includes a device controller **308a**, audible devices **308b**, a keypad **308c**, a visual display **308d** and a transceiver **308e**. The device controller **308a** is capable of controlling and integrating the operation of audible devices **308b**, the keypad **308c**, the visual display **308d** and the transceiver **308e**. The audible devices **308b**, such as a microphone and a speaker, permit the transaction requester **312** to submit and hear spoken information. The keypad **308c** permits the transaction requester **312** to submit keyed-in information. The visual display **308d** permits the transaction requester **312** to view visual information being received by and communicated from the wireless communication device **308**.

[0062] The transceiver **308e** is capable of enabling the communication of voice and data information between the wireless communication device **308** and the telecommunications network system **310**. In this manner, information is communicated to and from the transaction management system **302** and the transaction fulfillment system **304**. In the embodiment of the system architecture illustrated in **Fig. 4**, voice and data information is communicated to and from the transaction management system **302**, and only data information is communicated to and from the transaction fulfillment system.

[0063] As illustrated in **Fig. 5**, the wireless communication device **308** includes a scrolling device **308e**. A user interface **308f** is displayable on the visual display **308d** of the wireless communication device **308**. Using the scrolling device **308e**, a desired transaction code name **308g** is selected from a list of transaction code names **308h** displayed on the visual display **308d**. An optically scannable transaction code **308i** is displayed on the visual display **308d** in response to selecting the desired transaction code name **308g**.

[0064] A wireless application protocol (WAP) enabled wireless telephone illustrates an example of the wireless communication device **308**. In addition to WAP enabled wireless telephones and devices, wireless communication devices operating under other wireless protocols such as imode, sms and hdml may be utilized with the methods and systems disclosed herein. Wireless telephones capable of accessing computer networks, such as the Internet, are commercially available from several wireless telephone manufacturers.

[0065] The transaction apparatus **300** of **Fig. 4** permits wireless transaction to be carried out by telephonic-type wireless communication devices, such as Internet enabled wireless telephones. However, by replacing the telecommunication network system with a wireless local area network system or adding a wireless local area network system to the transaction apparatus **300**, the transaction apparatus **300** may be used for facilitating a wireless transaction using a non-telephonic Internet enabled telephonic communication device, such as a wireless PDA. When carrying out transaction requests with such a non-telephonic wireless communication device, authentication of the transaction requester may be more effectively achieved by known data password techniques rather than voice authentication.

[0066] The transaction apparatus **300**, **Fig. 4**, is capable of enabling communication directly between a transaction fulfillment system **304** and a wireless communication device **308**. To this end, the transaction fulfillment system **304** and the wireless communication device **308** each include a low power short range digital radio **314** integrated therein. Each digital radio **314** includes a radio transceiver for enabling voice and data information to be communicated between the transaction fulfillment system **304** and the wireless communication **308** without being communicated through the computer network system **306** or the telecommunication network system **310**. The speed of information transfer between the transaction fulfillment system **304** and the wireless communication device **308** is significantly increased by eliminating the need to communicate such information through the computer network system **306** and the telecommunication network system **310**.

[0067] A Bluetooth™ radio illustrates one example of the digital radio **314**. Bluetooth radios are based on a radio specification governed by the Bluetooth Special Interest group. The specification defines the standards for a tiny microchip that comprise a radio transceiver. Accordingly, Bluetooth radios are built into digital devices, such as cellular telephones, PDA, portable computers, etc.

[0068] The Bluetooth radio makes communication of information nearly instant. It facilitates fast and secu-

re transmissions of both voice and data, even when the devices are not within line-of-sight. The transceivers operates in a globally available frequency band, ensuring compatibility worldwide. The Ericsson R520 wireless telephone illustrates an example of a Bluetooth enabled wireless telephone. The R520 telephone is a triple mode phone with GPRS, Bluetooth radio, WAP capabilities.

[0069] A key aspect of the system and method embodiments disclosed herein is the ability and functionality associated with optically scanning transaction codes from the visual display of the wireless communication device. Optical scanning of transaction codes facilitates a convenient and secure technique for allowing fulfillment of real world products and services from a wireless transaction. The transaction requester must simply pass the visual display of the wireless communication device over the barcode reader of the transaction fulfillment system to act on fulfillment of the wireless transaction.

[0070] Many wireless communication devices, such as wireless telephones and wPDA's, have relatively small visual displays. As a result, optically scannable code communicated to the wireless communication devices must be relatively compact. One-dimensional barcodes and truncated two-dimensional barcodes illustrate examples of suitable barcodes for being communicated to devices having visual displays that are capable of displaying bitmap images. It is anticipated that over time most commercially available wireless communication devices will be capable of displaying larger barcodes, such as two-dimensional barcodes. One of the advantages of a two-dimensional barcode is the ability to embed several thousand bytes of information in the barcode.

[0071] Bar codes configured according to Code 128 Specification illustrates an example of a bar code configuration that is well suited for small visual displays of wireless telephones. Furthermore, most barcode readers in use today are capable of reading Code 128 barcodes. Code 128 barcodes are a very high-density alphanumeric symbology. The symbol can be as long as necessary to store the encoded data. It is designed to encode all 128 ASCII characters, and will use the least amount of space for data of 6 characters or more of any 1-D symbology. Each data character encoded in a Code 128 symbol is made up of 11 black or white modules. The stop character, however, is made up of 13 modules. Three bars and three spaces are formed out of these 11 modules. Bar and spaces can vary between 1 and 4 modules wide.

[0072] Presently, several commercially available wireless communication devices are not suitable capable of displaying bitmap images. A solution for communicating an optically scannable code to these types of wireless communication devices is to com-

municate a type of "hash code" to these of devices. One example of a hash code includes a string of forward slashes (/), representing a binary 1, and backward slashes (\), representing a binary 0. Suitable software would be required for decoding these types of code.

[0073] As illustrated in [Fig. 4](#), the transaction management system (TMS) **302**, transaction fulfillment system (TFS) **304**, the client computer system (CCS) **305** and the wireless communication device (WCD) **308** are coupled in a manner for communicating information therebetween. In this embodiment, verification of the transaction barcodes and communication of the transaction barcodes are facilitated by the TMS **302**. Furthermore, communication for determining the desired transaction is facilitated by the TMS **302**.

[0074] Referring to [Fig. 6](#), an operation A of receiving, at the TMS **302**, a transaction request from the WCD **308** is performed. After receiving the transaction request, an operation B of communicating a request for a spoken transaction requester authentication code (TRAC) from the TMS **302** to the WCD **308** is performed. The request for the spoken TRAC is intended to initiate an operation C of receiving, at the TMS **302**, a spoken TRAC from the WCD **308**. An operation D of communicating a requester authentication message (RAM) from the TMS **302** to the WCD **308** initiates an operation E of communicating a first transaction barcode (FTB) to the WCD **308**. The request authentication message confirms that the transaction request is approved and that the FTB has been communicated. The TFS **304** and the TMS **302** may interact with the CCS **305** to facilitate and enable fulfillment of the transaction request.

[0075] An operation F of scanning the FTB is performed after the operation E. In response to scanning the FTB, an operation G of receiving, at the TMS **302**, a decoded representation of the FTB from the TFS **304** is performed. After receiving the decoded representation of the FTB and in response to the FTB being verified, an operation H of communicating a second transaction barcode (STB) from the TMS **302** to the WCD **308** is performed. A first fulfillment event is typically also performed in response to the FTB being verified. An operation I of scanning the STB is performed after the operation H. In response to scanning the STB, an operation J of receiving, at the TMS **302**, a decoded representation of the STB from the TFS **304** is performed. After receiving the decoded representation of the STB and in response to the STB being verified, an operation K of communicating a transaction fulfillment message (TFM) from the TMS **302** to the WCD **308** is performed. A second fulfillment event is typically performed in response to the FTB being verified. Communication of the TFM may be part of the second fulfillment event.

[0076] After scanning and decoding the FTB and the STB, internal operations are conducted by the TFS **304**, the TMS **304** or both. One such internal operation is communicating with a client computer system for enabling facilitation of the requested transaction. The TMS **302**, the TFS **304** or both may use the fulfillment verification to initiate subsequent internal operations, such as removing a particular transaction offering from being available to transaction requesters.

[0077] The first and second transaction barcodes enables the transaction requester to act on fulfillment of the real world products or services requested in the transaction request. Renting and taking possession of a rental car using a cellular telephone represents a viable commercial implementation of the methods disclosed herein, the system illustrated in [Fig. 4](#) and the operations described in reference to [Fig. 7](#).

Example 1 – Car Rental

[0078] A transaction requester who will be travel by plane to a different city uses his Internet enabled wireless telephone for renting a car for use during his trip. To this end, he contacts the TMS using his wireless telephone. He then interacts with a transaction requester user interface (TRUI) of his wireless telephone for communicating car rental information to and from car rental information from the TMS. The car rental information includes typical car rental information, such as rental dates, the type of car, etc. The TMS interacts with the OCS to complete the transaction request. For example, the TMS may interact with the OCS to determine whether the selected type of vehicle is available on the desired days. After he completes the transaction request, his identity is authenticated using voice authentication techniques, such as those described herein.

[0079] After authenticating his identity, a FTB is communicated to his wireless telephone. When he arrives at the air port of the city he is traveling to, he accesses the TRUI for retrieving the FTB. He then passes the wireless telephone over one of many barcode readers of the TFS that are located throughout the airport. By doing so, the FTB is optically scanned from the visual display of his wireless telephone. By scanning the FTB, he has confirmed with the TFS that he has arrived at the airport and expects the car to be ready. After scanning the FTB, a STB is communicated to his wireless telephone.

[0080] He then makes his way to the car rental lot. Once at the car rental lot, he accesses the TRUI for retrieving the STB. After retrieving the STB, he optically scans the STB from the visual display of his wireless telephone using a barcode reader that is located at the car rental lot. By scanning the STB, he has confirmed with the TFS that he has arrived at the car rental lot and is ready to take possession of the

rental car. After scanning the STB, a TFM may be communicated to his wireless telephone. In such an instance, the TFM includes information, such as direction to his hotel, information about the city, etc.

[0081] This example illustrates the convenience and time savings associated with using the methods and systems disclosed herein for renting a car when traveling. The advantages are especially significant to business travelers, as their schedules often change on short notice. However, the advantages associated with these methods and systems afford travelers of all types with a means of maintaining a tight travel schedule.

[0082] An embodiment of a transaction apparatus for carrying out the methods of [Fig. 1–Fig. 3](#) using a non-telephonic wireless communication device is illustrated in [Fig. 7](#). The transaction apparatus **400** includes a transaction fulfillment system **402** coupled to a transaction fulfillment system **404** and to a client computer system **405**. It is also contemplated that in some applications it may be advantageous for the client computer system to be omitted from or discrete from the transaction apparatus **400**. The transaction management system **402** is coupled to the transaction fulfillment system **404** through a computer network system **406**.

[0083] A wireless communication device **408**, such as a wireless personal digital assistant, communicates with the transaction management system **402** and the transaction fulfillment system **404** through a wireless data network system **410** and the computer network system **406**. A transaction requester **412** utilizes the wireless communication device **408** for communicating with the transaction management system **402** and the transaction fulfillment system **404**.

[0084] The wireless data network system **410** is a network system for providing wireless connectivity of non-telephonic wireless communication devices. The wireless data network system **410** may include a wireless local area network, a device specific wireless network or both. Examples of non-telephonic wireless communication devices include notebook computers including wireless modems and wireless PDA's.

[0085] The Cisco® Aironet™ wireless local area network illustrates an example of the wireless local area network system **410**. The Aironet wireless LAN system includes an Aironet **340** family of access points. The access point acts as a bridge integrate wireless functionality into a wired infrastructure. The Aironet wireless LAN system also includes an Aironet **340** Series family of client adapters. One example of a client adapter is an Aironet wireless data modem that plugs into a PCMCIA connector of a portable computer. The wireless data modem permits the portable computer to communicate with a network computer

system such as the Internet via the Aironet 340 Series access point.

[0086] The PalmNet™ illustrates an example of a device specific wireless network. The PalmNet provides wireless connectivity of PDA's offered by Palm Computing Corporation. Through the PalmNet, users of Palm Computing PDA's can communicate information through a global computer network system such as the Internet.

[0087] The transaction management system 402 includes a central processing unit (CPU) 402a, an information storage device 402b, a network interface system 402c and barcode software 402d. A network server or a workstation, such as those identified above in reference to Fig. 4, comprise the CPU 402a. The information storage device 402b, such as that identified above in reference to Fig. 4, is coupled to the CPU 402a for storing information in non-volatile memory. Fulfillment information, barcode information and transaction requester passwords illustrate examples of information that may be retrieved from information storage device 402b.

[0088] The network interface system 402c, such as that identified above in reference to Fig. 4, is coupled to the CPU 402a for facilitating the communication of information between the transaction management system 402, the computer network system 406 and the wireless communication device 408. The barcode software 402d, such as that indicated above in reference to Fig. 4, enables encoding and decoding of barcodes. The barcode software 402d is accessible by the CPU 402a from a computer readable medium, such as a compact disk, disk drive or network connection.

[0089] The transaction fulfillment system 404 includes a central processing unit (CPU) 404a, an information storage device 404b, a network interface system 404c, a barcode reader 404d, and barcode software 404e. The transaction fulfillment system 404 includes a central processing unit (CPU) 404a. A network server or workstation, such as those identified above in reference to Fig. 4, comprise the CPU 404a. The information storage device 404b, such as that identified above in reference to Fig. 4, is coupled to the CPU 404a for storing information in non-volatile memory. Fulfillment reply information, transaction codes, product information, and barcode information illustrate examples of information that may be retrieved from the information storage device 404b.

[0090] The network interface system 404c, such as that identified above in reference to Fig. 4, is coupled to the CPU 404a for facilitating the communication of information between the transaction fulfillment system 404, the computer network system 406 and the wireless communication device 408. The bar code re-

ader 404d, such as that identified above in reference to Fig. 4, enables barcodes to be optically scanned and decoded. The barcode reader 404d is coupled to the CPU 404a for communicating a scanned representation of a barcode to the CPU 404a.

[0091] The barcode software 404e, such as that identified above in reference to Fig. 4, enables the encoding and decoding of barcodes. The barcode software 404e is accessible by the CPU 402a from a computer readable medium, such as a compact disk, disk drive or network connection.

[0092] The client system 405 is the system of the entity that offers the product or service requested in the transaction request. The client computer system 405 communicates with the transaction management system 402 and the transaction fulfillment system 404 to facilitate the transaction. The client system 405 includes a network interface a CPU 405a, an information storage device 405b and a network interface device 405c. The CPU 405a is coupled to the information storage device 405b for storing information, such as product and service information, in non-volatile memory. The network interface device is coupled between the CPU 405a and the computer network system 406 for enabling communication therebetween.

[0093] The wireless communication device 408 includes a device controller 408a, an audible output component 408b, a touch screen-type visual display 408c and a data transceiver 408d. The device controller is capable of controlling and integrating the operation of the audible output component 408b, the touch screen-type visual display 408c and the data transceiver 408d. The audible output component 408b, such as a speaker, permit the transaction requester to hear spoken information. The touch screen type visual display 408c permits the transaction requester 412 to input information by touching the visual display 408c, by writing on the visual display 408c or both.

[0094] The data transceiver 408d is capable of enabling the communication of data information between the wireless communication device 308, the transaction management system 402 and the transaction fulfillment system 404. The transceiver may also be capable of communicating voice information between the wireless communication device 308 and the wireless local area network system 410. In this manner, information is communicated between the wireless communication device 408, the transaction management system 402 and the transaction fulfillment system 404.

[0095] As illustrated in Fig. 8, the visual display 408c of the wireless communication device 308 includes a touch screen type visual display. A user interface 408e is displayable on the visual display 408c of the

wireless communication device **408**. Using a suitable physical pointing device, a desired transaction code name **408f** is selected from a list of transaction code names **408g** displayed on the visual display **408c**. An optically scannable transaction code **408h** is displayed on the visual display **408c** in response to selecting the desired transaction code name **408f**. A wireless personal digital assistant illustrates an example of the wireless communication device **408**.

[0096] As illustrated in [Fig. 7](#), the transaction management system (TMS) **402**, transaction fulfillment system (TFS) **404**, the client computer system (CCS) **405** and the wireless communication device (WCD) **408** are coupled in a manner for communicating information therebetween. In this embodiment, verification of the transaction barcodes and communication of the transaction barcodes are facilitated by the TFS **404**.

[0097] Communication for determining the desired transaction is facilitated by the TMS **402**. Referring to [Fig. 9](#), an operation A' of receiving, at the TMS **402**, a transaction request from the WCD **408** is performed. After receiving the transaction request, an operation B' of communicating a request for a password from the TMS **402** to the WCD **408** is performed. The request for the password is intended to initiate an operation C' of receiving, at the TMS **402**, a password from the WCD **408**. An operation D' of communicating a requester authentication message (RAM) from the TMS **402** to the WCD **408** initiates an operation E' of communicating a first transaction barcode (FTB) to the WCD **408**. The RAM confirms that the transaction request is approved and that the FTB has been communicated. The TFS **404** and the TMS **402** may interact with the CCS **405** to facilitate and enable fulfillment of the transaction request. The FTB is used by the transaction requester to act on fulfillment of the real world products or services requested in the transaction request. The TFS **404** and the TMS **402** may interact with the CCS **405** to facilitate and enable fulfillment of the transaction request.

[0098] An operation F' of scanning the FTB is performed after the operation E'. In response to performing the operation F', a decoded representation of the FTB is generated at the TFS **404**. After scanning and decoding the FTB and in response to the STB being verified, an operation G' of receiving, at the TMS **402**, a first fulfillment verification (FFV) from the TFS **404** is performed. A first fulfillment event is typically also performed in response to the FTB being verified. The TMS **302**, the TFS **304** or both may use such verification to initiate subsequent internal operations, such as removing a particular transaction offering from being selectable by the transaction requester.

[0099] After scanning the FTB, an operation H' of communicating a second transaction barcode (STB)

from the TFS **404** to the WCD **408** is performed. An operation Γ of scanning the STB is performed after the operation H'. In response to scanning the STB, a decoded representation of the STB is generated at the TFS **404**. After the STB is scanned and in response to the STB being verified, an operation J' of receiving, at the TMS **402**, a second fulfillment verification (SFV) from the TFS **404** is performed. A second fulfillment event is typically also performed in response to the STB being verified.

[0100] The first and second fulfillment verifications illustrates an example of fulfillment verifications. Such verifications from the TFS **404** notify the TMS **402** that the transaction has been initiated or completed. After the STB is scanned, an operation K' of communicating a transaction fulfillment message (TFM) from the TFS **402** to the WCD **408** is performed.

Example 2 – Movie Theater

[0101] A transaction requester uses her wireless PDA to purchase a ticket to a desired movie while on her way to the theater. To this end, she contacts the TMS using her wireless PDA. She then interacts with a transaction requester user interface (TRUI) of her PDA for communicating movie information to and receiving movie information from the TMS. The movie information includes typical movie information such as the name of the movie and the time of the movie. The TMS interacts with the OCS to complete the transaction request. For example, the TMS may interact with the OCS to determine whether seats are remaining for the desired movie at a desired time. After completing the transaction request, her identity is authenticated in response to her keying in her password.

[0102] After authenticating her identity, a FTB is communicated to her PDA. When she arrives at the theater, she accesses the TRUI for retrieving the FTB. She then passes the PDA over a barcode reader that is located at the entrance of the theater. In this manner, the FTB is optically scanned from the visual display of her PDA. Scanning the FTB activates a first turnstile allowing her to gain entry into the lobby of the theater. In some instances, it may also activate a ticket dispenser in the turnstile to dispense a physical ticket for the specified movie. After scanning the FTB, a STB is communicated to her PDA.

[0103] She then makes her way toward the auditorium portion of the theater. To gain access to the auditorium portion of the theater, she retrieves the STB. After retrieving the STB, she passes the PDA over a barcode reader that is located at the entrance of the auditorium portion of the theater. Scanning the STB activates a second turnstile allowing her to gain access to the auditorium portion of the theater.

[0104] After scanning the STB, a transaction fulfillment message is sent to her PDA. The transaction fulfillment message includes information such as directions to the particular auditorium her movie is in, interactive or exclusive information about the movie, etc.

[0105] This example illustrates the convenience and time savings associated with using the methods and systems disclosed herein for attending a movie. In this example, the advantages associated with these methods and systems are even more pronounced during times of high traffic at movie theaters.

[0106] Fig. 10 illustrates another embodiment of an operation flowchart for the system illustrated in Fig. 7. In this embodiment verification of the transaction barcodes, communication of the transaction barcodes and communication for determining the desired transaction is facilitated by the TFS 404. An operation A" of receiving, at the TMS 402, a transaction request from the WCD 408 is performed. After receiving the transaction request, an operation B" of communicating a request for a password from the TMS 402 to the WCD 408 is performed. The request for the password is intended to initiate an operation C" of receiving, at the TMS 402, a password from the WCD 408. An operation D" of communicating a requester authentication message (RAM) from the TMS 402 to the WCD 408 initiates an operation E" of communicating the transaction request from the TMS 402 to the TFS 404. The RAM confirms that the password is approved. In this embodiment, the transaction request is communicated to the TFS 404 for enabling fulfillment of the transaction request by the TFS 404. The TFS 404 and the TMS 402 may interact with the CCS 405 to facilitate and enable fulfillment of the transaction request.

[0107] An operation F" of communicating a FTB from the TFS 404 to the WCD 408 is performed after the TFS 404 receives the transaction request. The FTB is used by the transaction requester to act on fulfillment of the real world products or services requested in the transaction request. An operation G" of scanning the FTB is performed after the operation F". In response to performing the operation G", a decoded representation of the FTB is generated at the TFS 404 and a first fulfillment verification operation is completed by the TFS 404.

[0108] After verifying the FTB, an operation H" of communicating a second transaction barcode (STB) from the TFS 404 to the WCD 408 is performed. An operation I" of scanning the STB is performed after the operation H". In response to scanning the STB, a decoded representation of the STB is generated at the TFS 404 and a second fulfillment verification operation is completed by the TFS 404. In response to verifying the STB, an operation J" of communicating

a transaction fulfillment message (TFM) from the TFS 402 to the WCD 408 is performed.

[0109] A multiple stage transaction method including the communication of two transaction codes is disclosed herein. It is contemplated and expected that the methods disclosed herein may be implemented in a manner in which a one stage transaction method or a multiple stage transaction method having three stages or more is provided. For example, in some applications, it will be advantageous to utilize a one stage transaction method in which only one transaction code, such as the first transaction code discussed herein, is communicated to the wireless communication device. It will be understood that the number of transaction codes communicated to the wireless communication device is dependent on the specific application, rather than being definitive of the systems and methods disclosed herein.

[0110] Commercial implementation of the methods and systems described herein may be accomplished in conjunction with one of many open or proprietary global specification that enables wireless communication device users to easily access and interact with information and services through the computer network systems described herein. One example of such an open global specification is the Wireless Application Protocol (WAP). WAP is designed to work with most wireless device architectures such as CDPD, CDMA, GSM, PDC, PHS, TDMA, FLEX, ReFLEX, iDEN, TETRA, DECT, DataTAC, Mobitex. Examples of WAP enabled wireless phones include the phone offered by Nokia under the model number 7110, the phone offered by Siemens under the model number S25, and the phone offered by Ericsson under the model number R380. Examples of WAP enabled wireless PDA's include the PDA offered by 3Com under the tradename PalmPilot VII and the PDA offered by Ericsson under the model number MC218.

[0111] WAP is a communications protocol and application environment. WAP technology can be included in the operating system of most wireless communication devices, including PalmOS, EPOC, Windows CE, FLEX-OS, OS/9, JavaOS etc. It provides service interoperability even between different device families. Additional details regarding the WAP can be obtained from the Wireless Application Protocol Forum Ltd. (www.wapforum.org) and from Dynamical Systems Research Ltd. (www.wap.net).

[0112] Symbian (www.symbian.com) offers a technology and hardware system under the tradename EPOC that provides a complete solution for manufacturers of wire communication devices. EPOC Release 5 includes Symbian's entire technology platform for bringing EPOC and other technology of Symbian into the heart of the wireless industry. This includes technologies for supporting integrated Internet e-

mail, wireless text messaging, contacts database and schedule, Internet-standard web browser, synchronization between EPOC-based and PC-based personal information and document formats, and a high-performance implementation of a wireless application language offered by Sun Microsystems under the trade name Java. EPOC provides robustness, compactness and performance that are delivered through careful system design in programming languages including C++.

[0113] WAP gateways are applications capable of enabling Internet content to be delivered to wireless communication devices. WAP gateways include the gateways offered by Opensource, Ericsson, Apion, Mobileways, Nokia, Unwired Planet, and Edgemail.

[0114] Dynamical Systems Research offers the WAP Developer's Toolkit (WDT). WDT supports the development of WAP applications. WAP applications use Wireless Mark-Up Language (WML) and Wireless Mark-Up Language Script (WML Script). WML's are used to create WAP pages in a manner similar to how HTML is used to create web pages for the Internet/World Wide Web. WMLScript is a script language for creating and laying out actual page content.

[0115] Phone.com offers UP.SDK, a freely available software development kit accessible at www.phone.com/products/upsdk.html, that enables Web developers to quickly and easily create HDML and WML information services and applications. UP.SDK includes a software development tool referred to as the UP.Simulator that accurately simulates the behaviour of an UP.Browser-enabled device. The simulator can run applications in local mode or connect to an UP.Link so developers can test the complete set of UP.Link-enabled services. Phone.com also provides a publicly available UP.Link for all developers to use freely so that they can create complete applications without the need for a handset or expensive carrier infrastructure. UP.SDK tools can be run on either Windows 95 or Windows NT (Windows 95 and Windows NT are trade names of Microsoft Corporation).

[0116] In the preceding detailed description, reference has been made to the accompanying drawings which form a part hereof, and in which are shown by way of illustration specific embodiments in which the invention may be practised. These embodiments, and certain variants thereof, have been described in sufficient detail to enable those skilled in the art to practice the invention. It is to be understood that other suitable embodiments may be utilised and that logical, mechanical, chemical and electrical changes may be made without departing from the scope of the invention. For example, functional blocks shown in the figures could be further combined or divided in any manner without departing from the scope of the invention. To avoid unnecessary detail, the description omits certain in-

formation known to those skilled in the art. The preceding detailed description is, therefore, not intended to be limited to the specific forms set forth herein, but on the contrary, it is intended to cover such alternatives, modifications, and equivalents, as can be reasonably included within the scope of the appended claims.

Patentansprüche

1. A method for facilitating a transaction using a wireless network, comprising:
 - receiving a transaction request at a transaction management system for a user selected transaction, said transaction request being received from an Internet-enabled wireless telephone (308) of the user; in response to the received transaction request, generating an optically scannable transaction code at the transaction management system;
 - communicating the optically scannable transaction code to the wireless telephone (308), the optically scannable transaction code being displayed on a visual display (308d) of the wireless telephone (308), the displayed optically scannable transaction code being scanned by a transaction fulfillment system for authorising fulfillment of the user selected transaction in response to the optically scannable transaction code being optically scanned; and
 - verifying fulfillment of the transaction.
2. A method according to claim 1, further including the step of authenticating the identity of the user.
3. A method according to claim 2, in which authenticating the identity of the user comprises voice authentication.
4. A method according to any one of the preceding claims, including the step of a user selecting a transaction, in response to which the transaction request is generated and sent to the transaction management system.
5. A method according to any one of the preceding claims, in which the optically scannable transaction code comprises a bar code.
6. A method according to any one of the preceding claims, further comprising verifying the read optically scannable transaction code.
7. A method according to claim 6, in which verifying the read optically scannable transaction code comprises decoding the read optically scannable transaction code and correlating this to a transaction fulfillment event.
8. A method according to any one of the preceding claims, including transmitting a second optically scannable transaction code to the wireless communi-

cations device (308) in response to fulfillment of the transaction.

telephone (308) in response to fulfillment of the transaction.

9. A method according to claim 8, in which the displayed optically scannable transaction code is scannable by a transaction fulfillment system for authorising fulfillment of a second transaction event in response to the optically scannable transaction code being optically scanned.

Es folgen 10 Blatt Zeichnungen

10. A method according to any of the preceding claims, in which the requested transaction is removed from a list of available transactions when the transaction is fulfilled.

11. A transaction apparatus (300) for facilitating a transaction using a wireless network, the apparatus capable of:
 receiving a transaction request for a user selected transaction from an internet-enabled wireless telephone (308) of the user;
 in response to the received transaction request, generating an optically scannable transaction code at a transaction management system;
 communicating the optically scannable transaction code to the wireless telephone (308), the optically scannable transaction code being adapted to be displayed on a visual display (308d) of the wireless telephone (308), the displayed optically scannable transaction code being adapted to be scanned by a transaction fulfillment system for authorising fulfillment of the user selected transaction in response to the optically scannable transaction code being optically scanned; and
 verifying fulfillment of the transaction.

12. An apparatus according to claim 11, in which the apparatus (300) is adapted to authenticate the identity of the user (312).

13. An apparatus according to claim 12, in which the apparatus (300) includes a speech services module for authenticating the identity of the (312) user using voice authentication.

14. An apparatus according to any one of claims 11 to 13, the apparatus further comprising an optical scanner for scanning the optically scannable transaction code displayed on the display of the wireless telephone (308).

15. An apparatus according to claim 14, in which the scanner is a bar code scanner.

16. An apparatus according to any one of claims 11 to 15, in which the transaction request apparatus (300) is further capable of communicating a second optically scannable transaction code to the wireless

Anhängende Zeichnungen

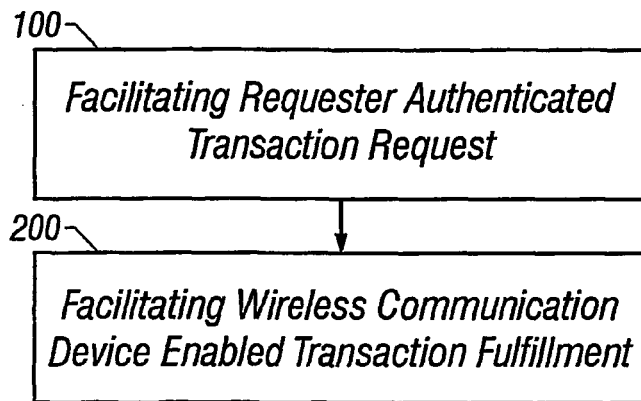

FIG. 1

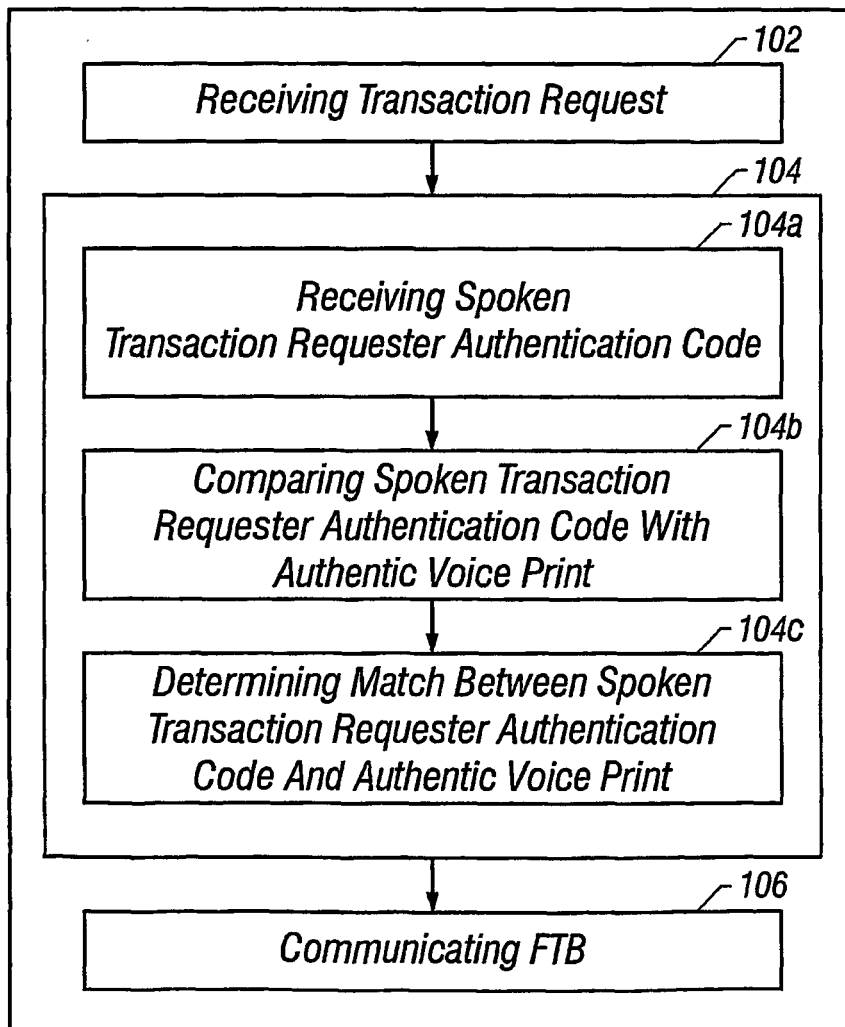

FIG. 2

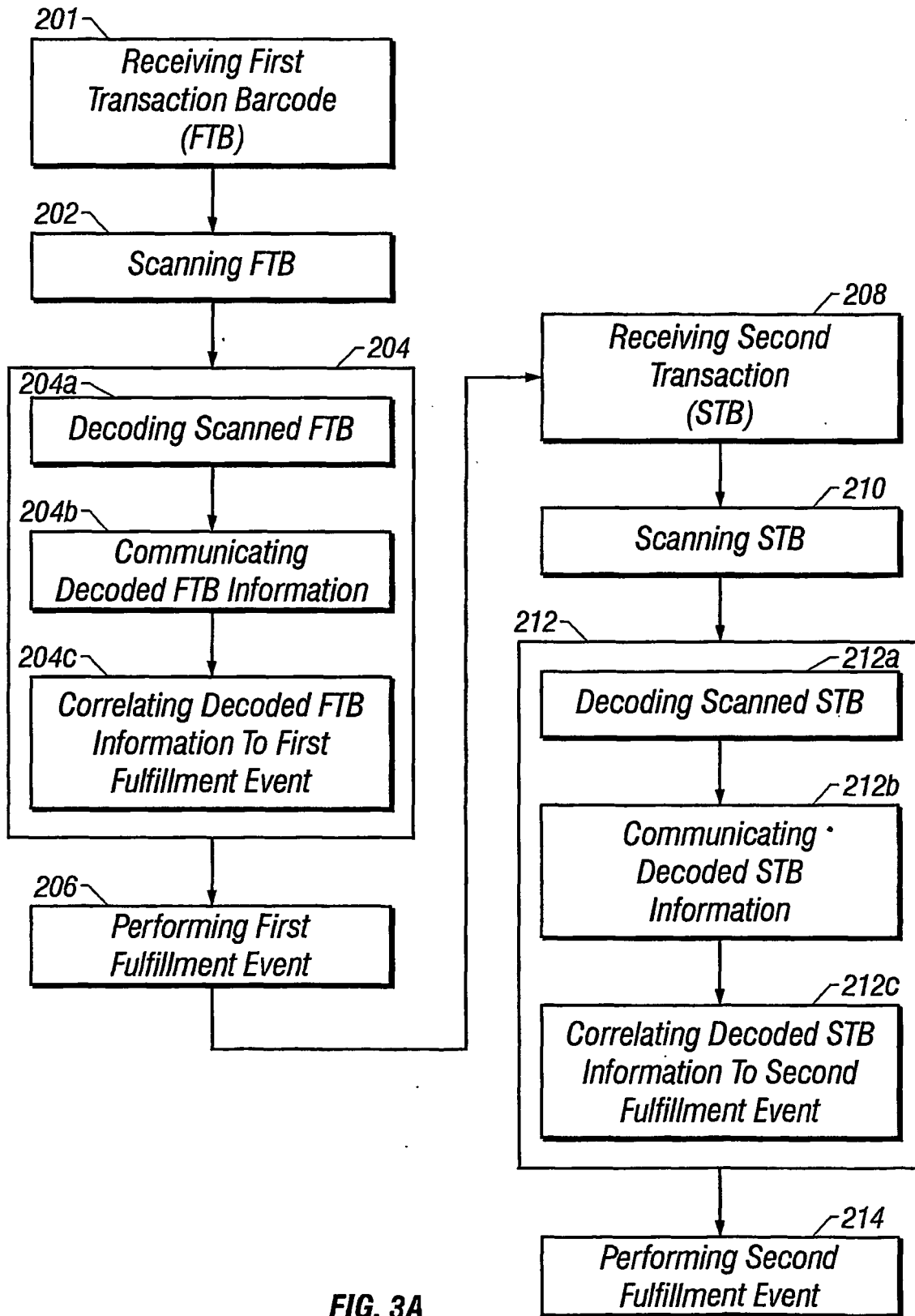

FIG. 3A

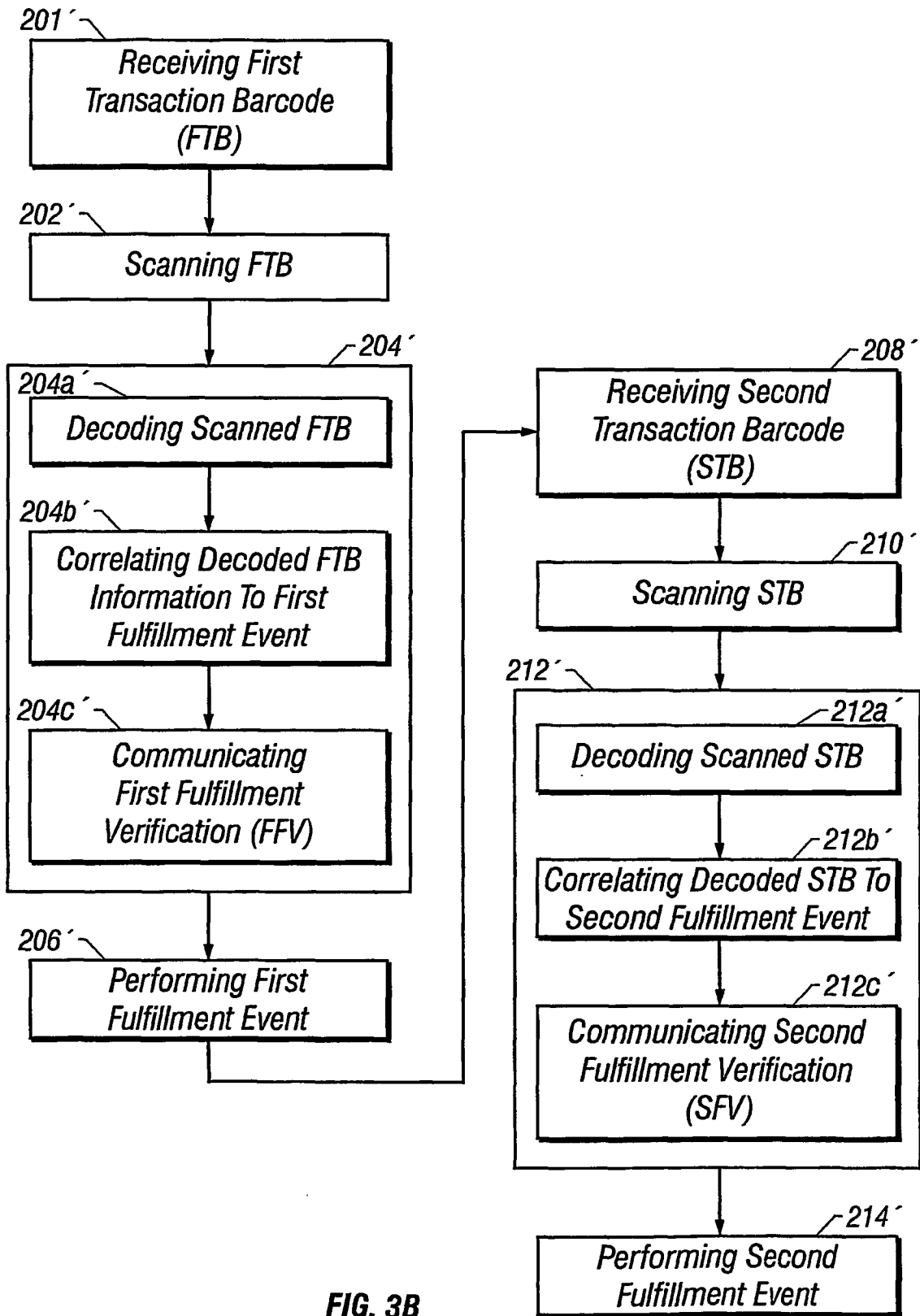
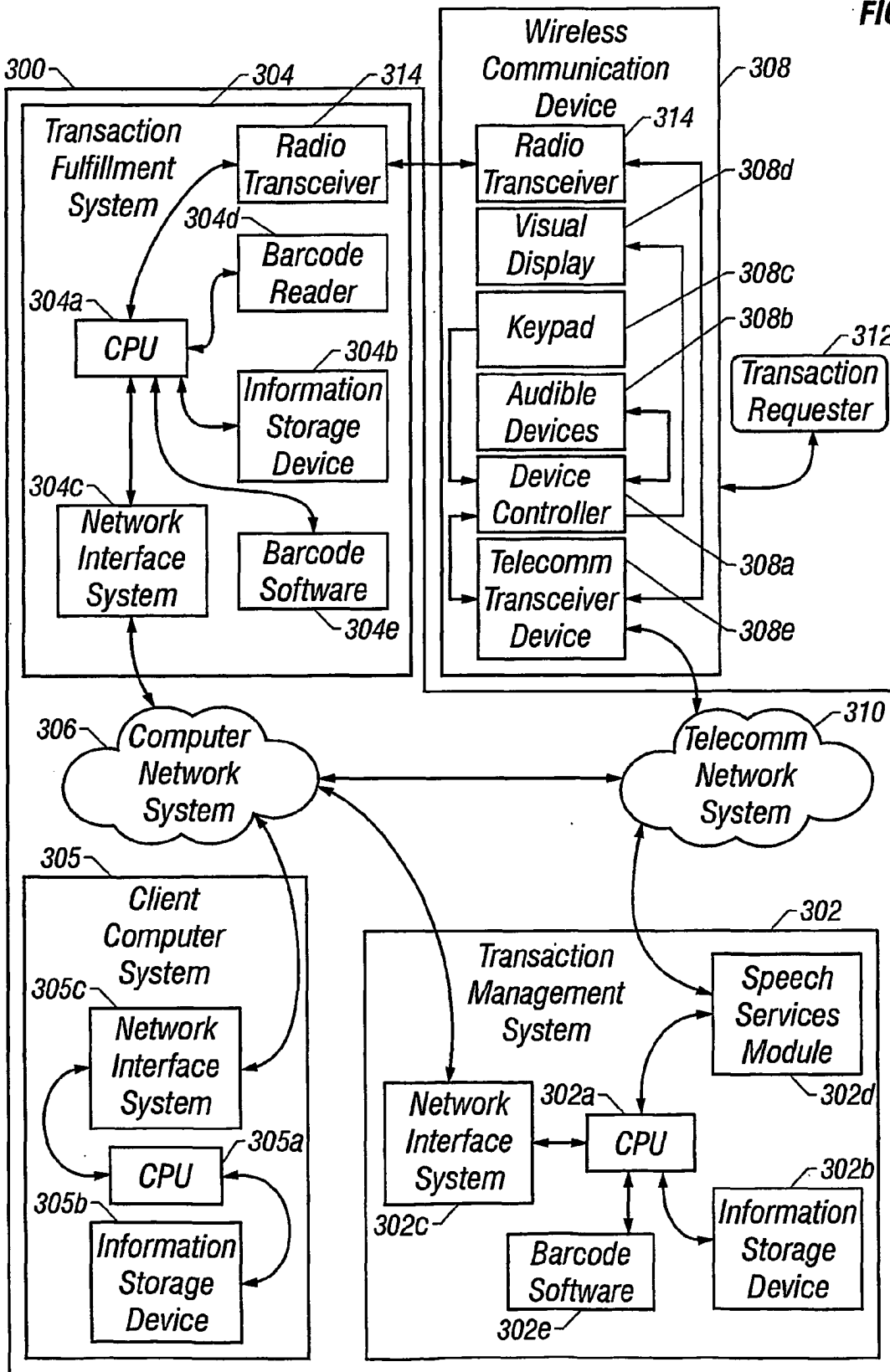

FIG. 3B

FIG. 4



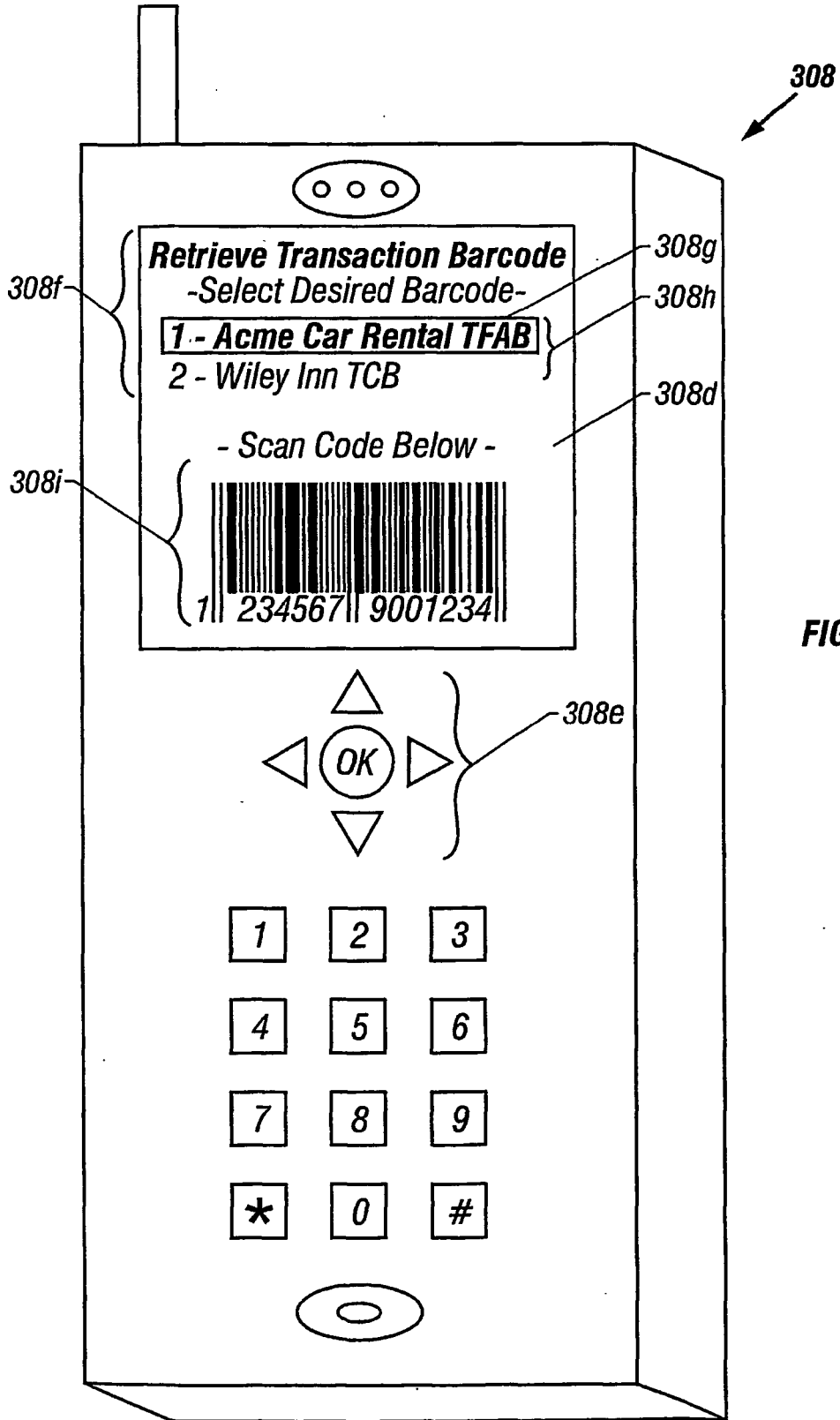

FIG.5

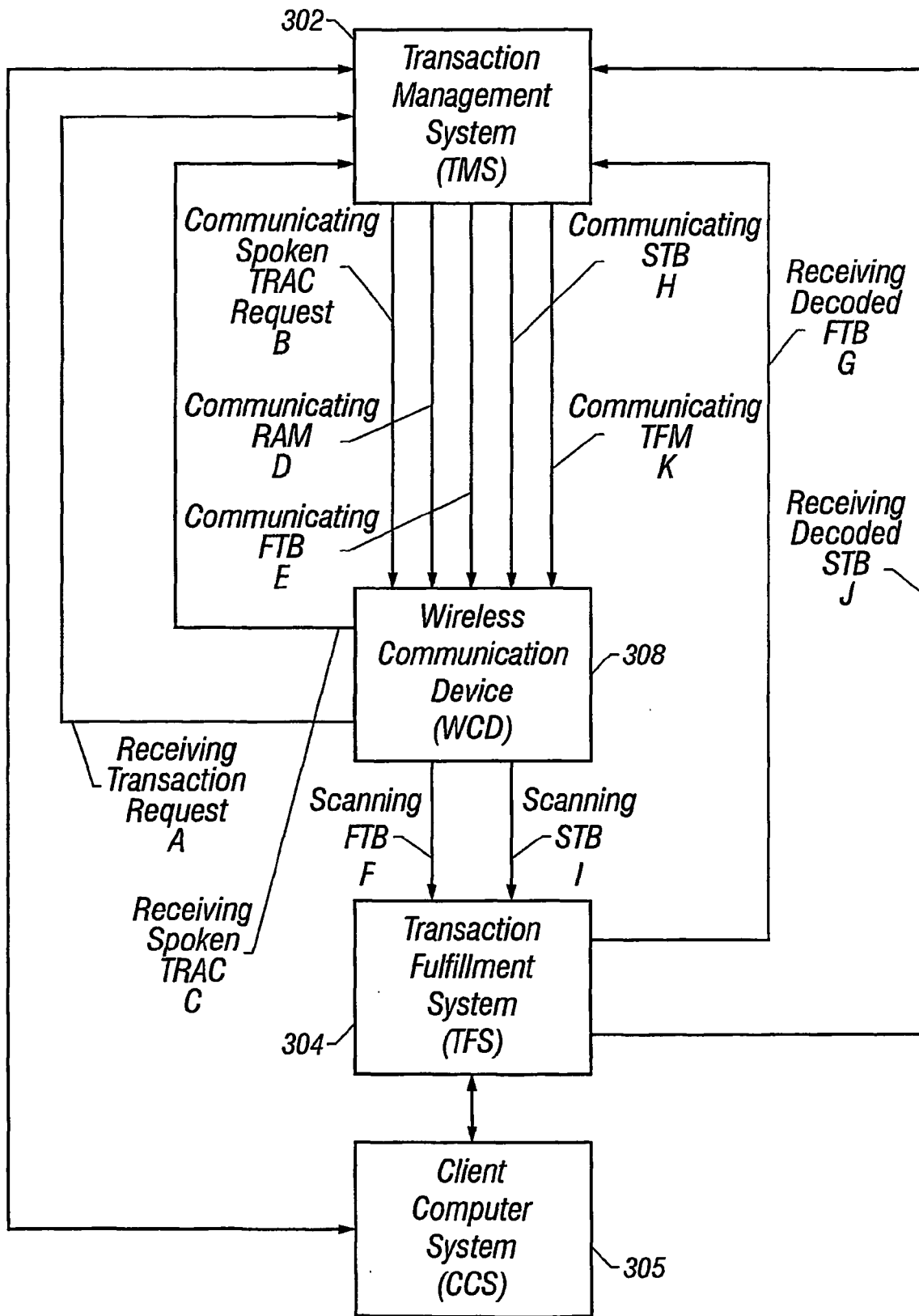
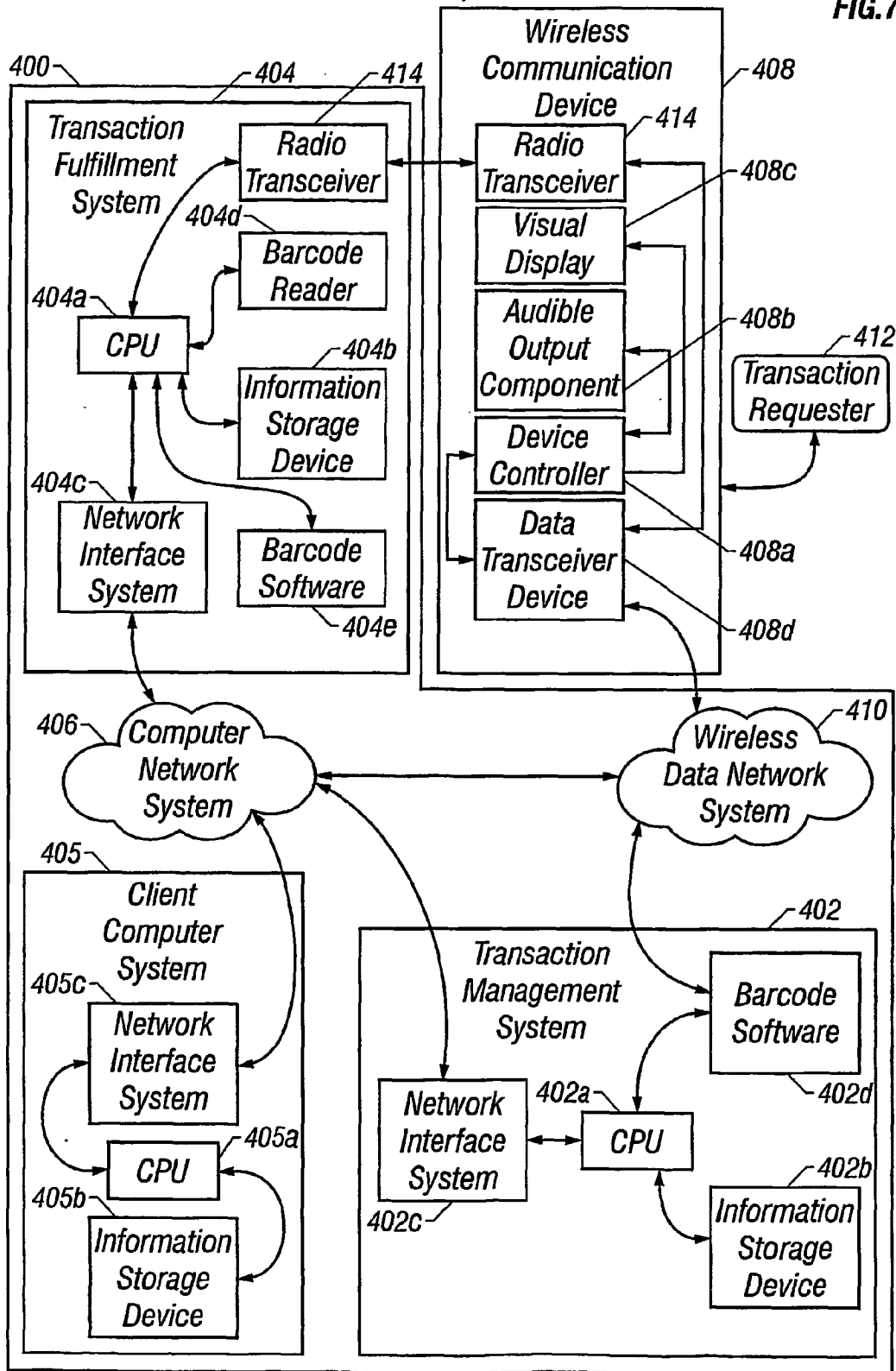

FIG. 6

FIG. 7



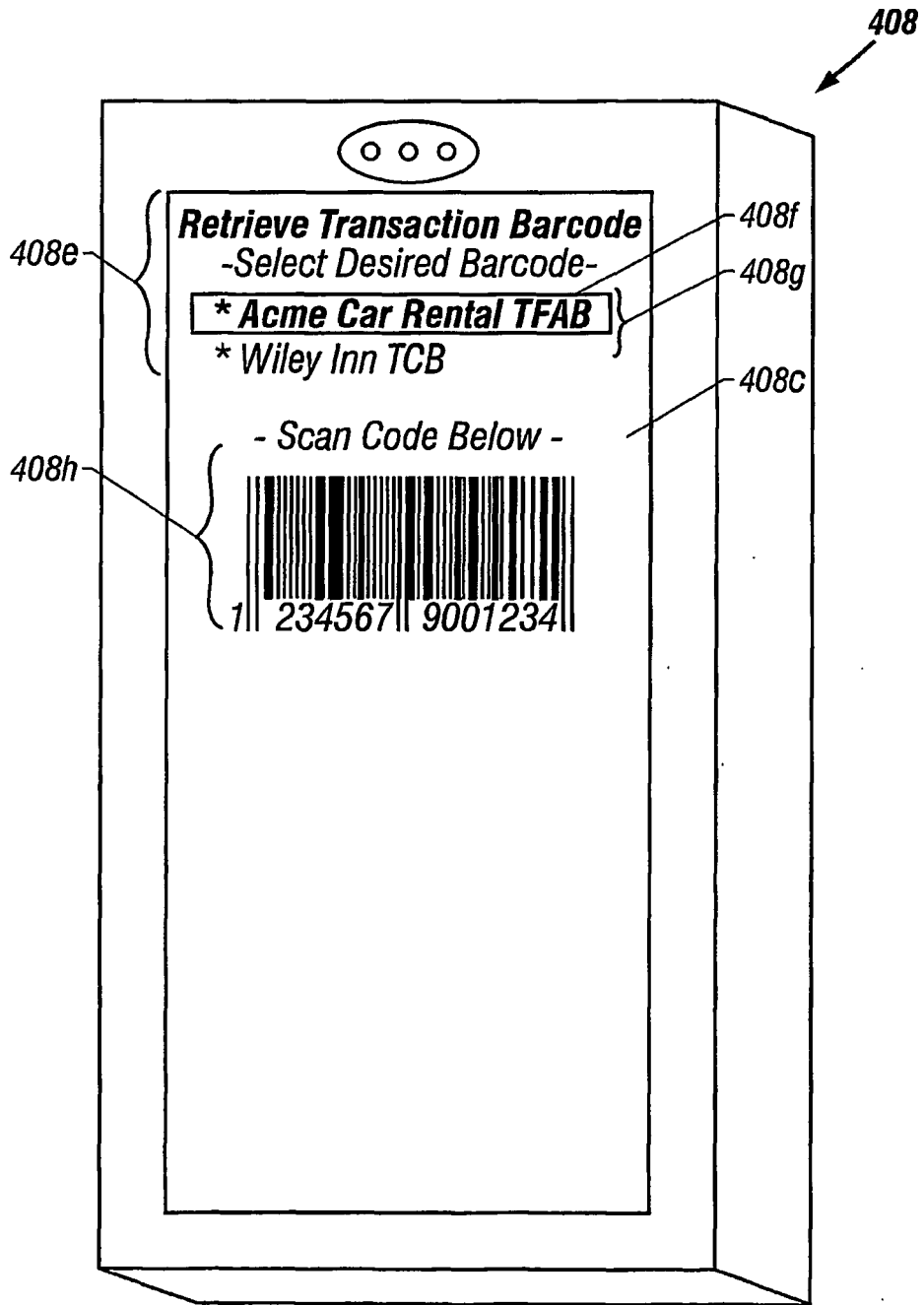

FIG.8

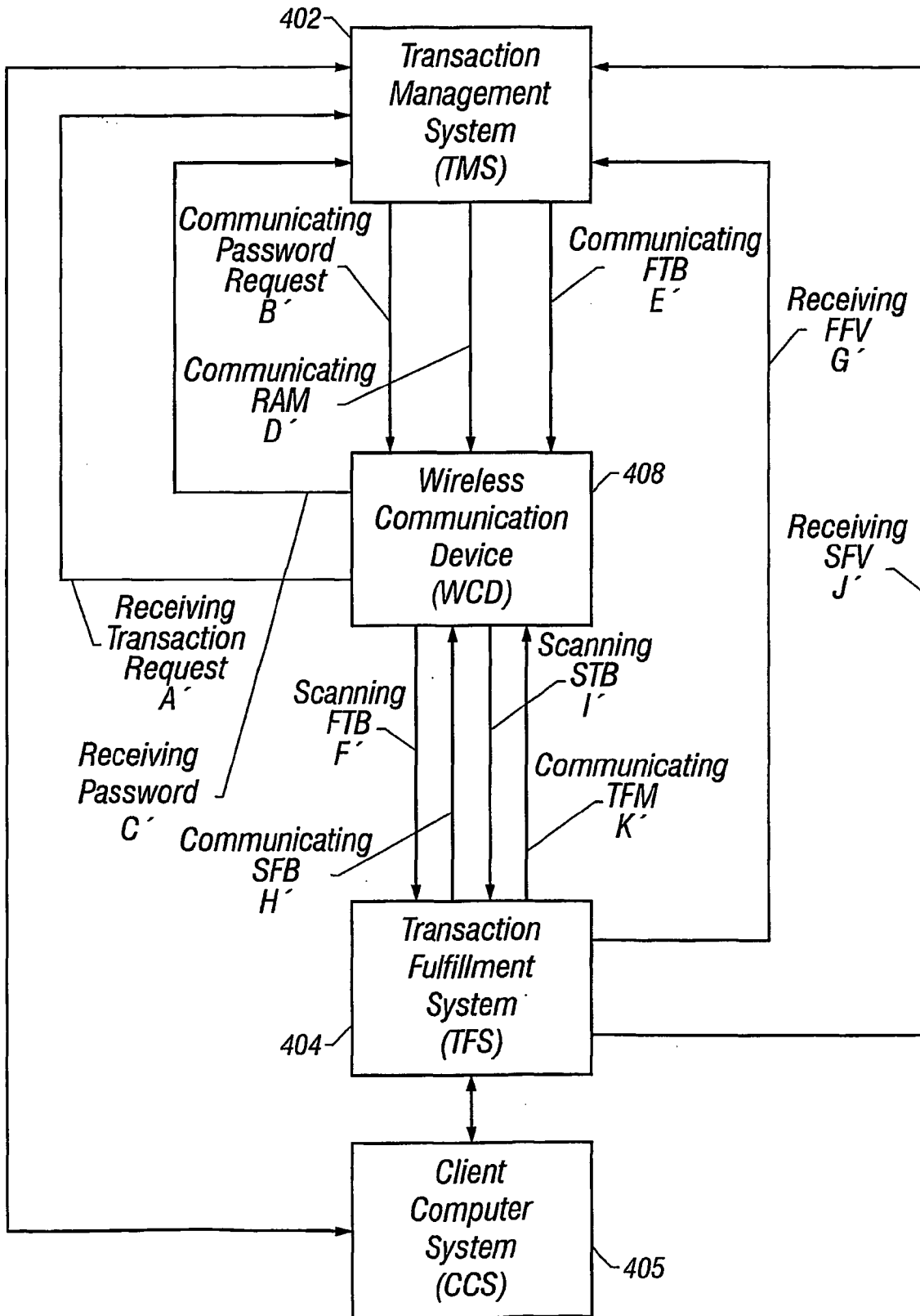

FIG. 9

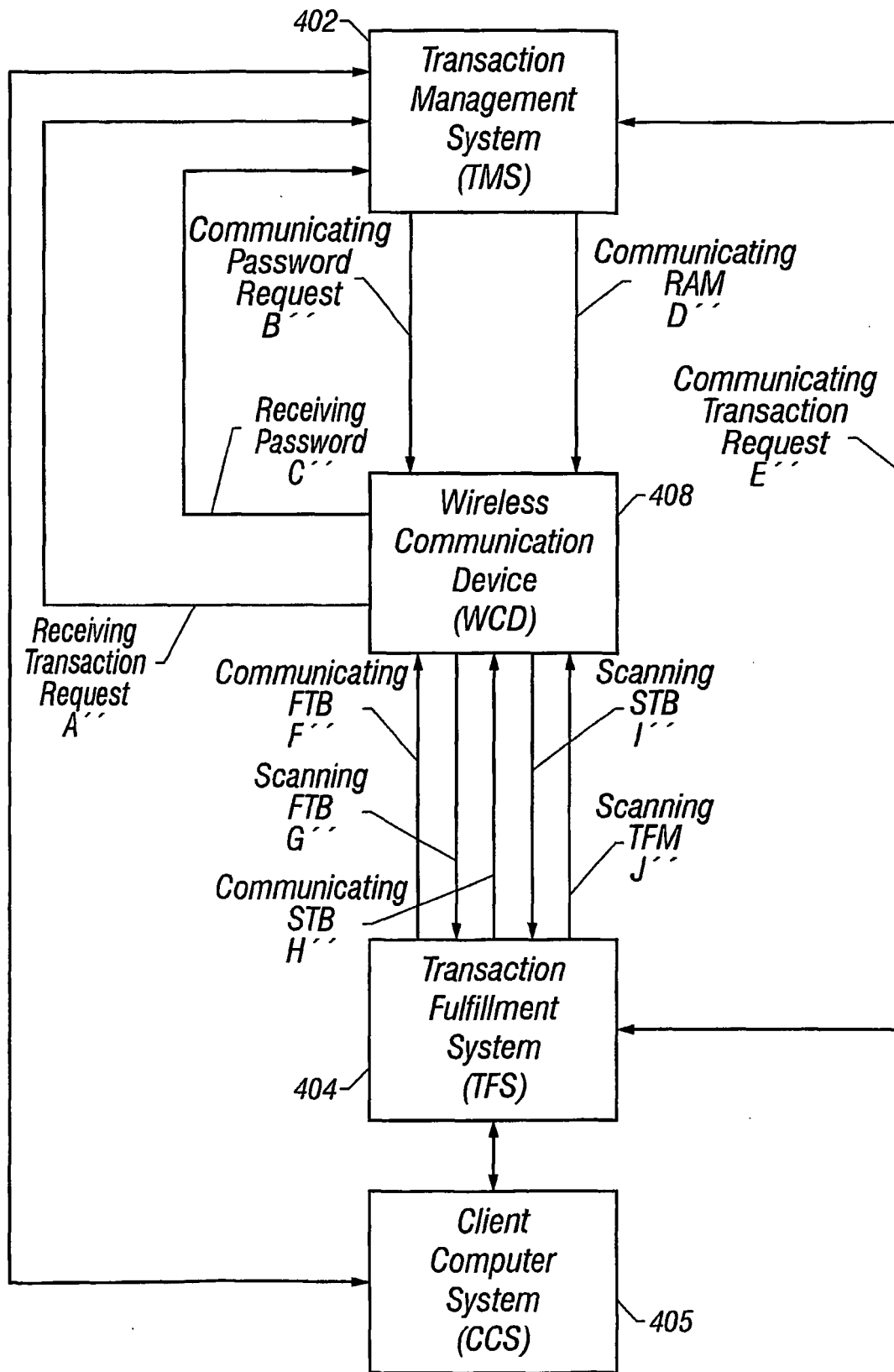

FIG. 10