

M. & A. WAISSNIX & C. A. SPECKER.  
MACHINE FOR PREPARING WOOD PULP.

No. 111,496.

Patented Jan. 31, 1871.

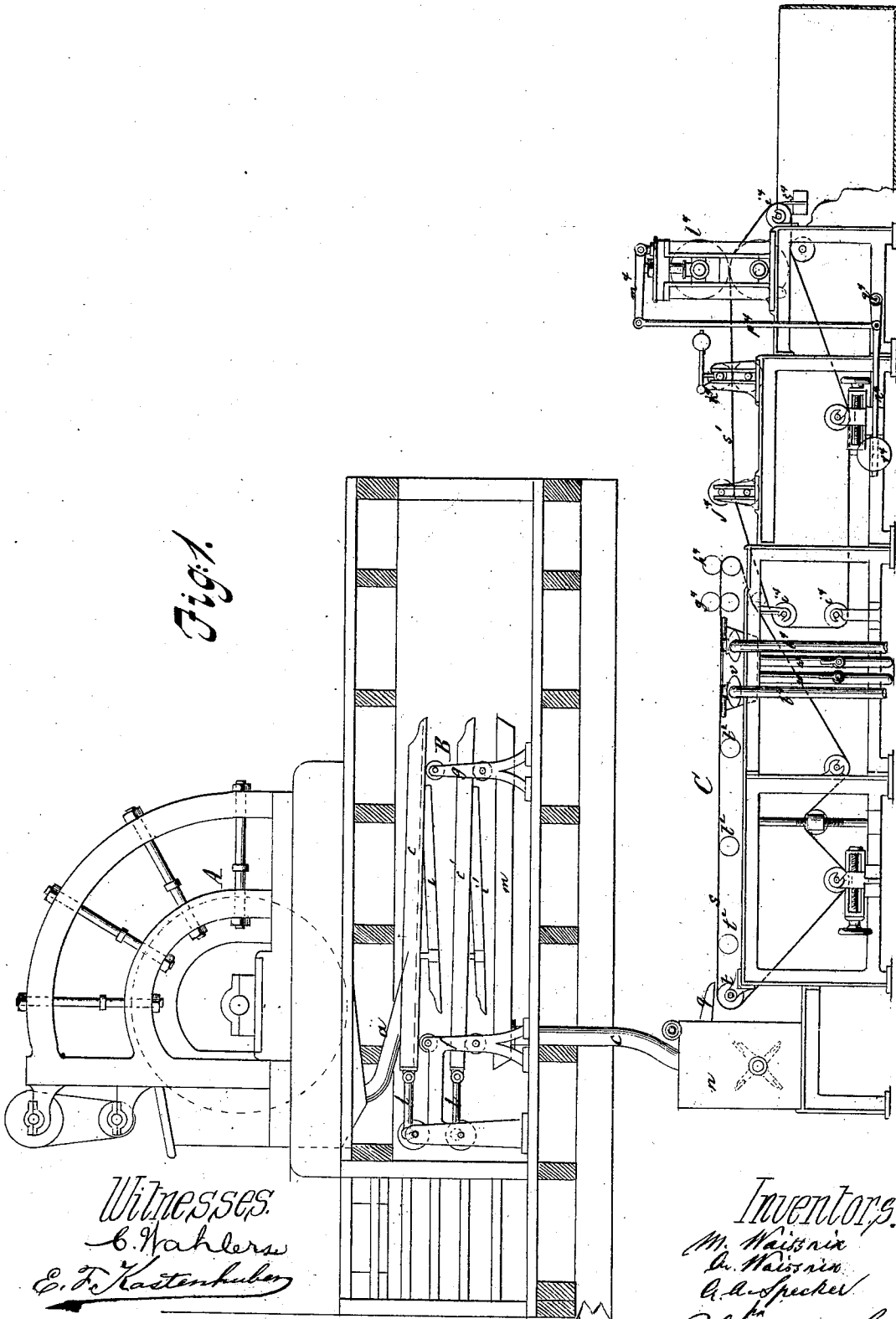

*Fig. 1.*

*Witnesses.*  
*G. Wahler*  
*E. F. Kastenhuber*

*Inventors.*  
*M. Waissnix*  
*A. Waissnix*  
*C. A. Specker*  
*Per*  
*Van Santvoord & Lang*

M. & A. WAISSNIX & C. A. SPECKER.  
MACHINE FOR PREPARING WOOD PULP.

No. 111,496.

Patented Jan. 31, 1871.

*Fig. 3.*

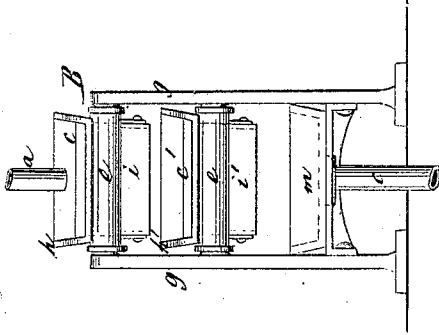

*Fig. 2.*

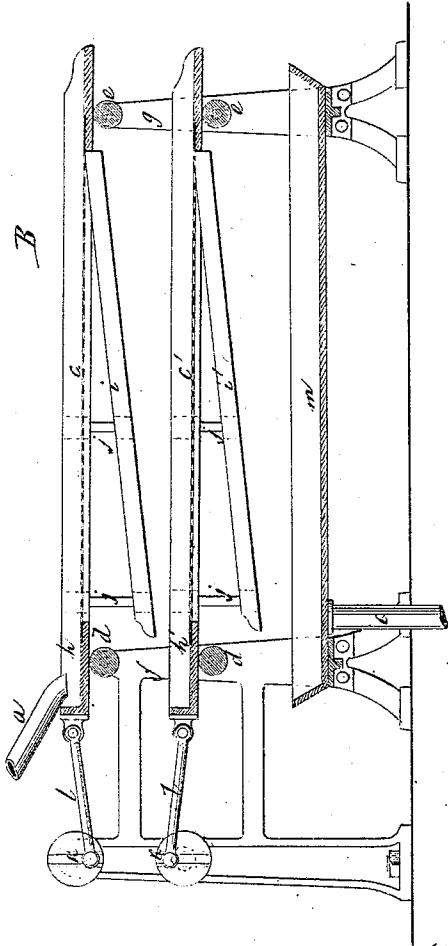

*Witnesses:*  
*G. Wahlers.*  
*E. F. Kastenhuber*

*Inventors.*  
*M. Waissnix*  
*A. Waissnix*  
*C. A. Specker*  
*Per*  
*Max Sartorius & Hauff*  
*1871*

M. & A. WAISSNIX & C. A. SPECKER.  
MACHINE FOR PREPARING WOOD PULP.

No. 111,496.

Patented Jan. 31, 1871.

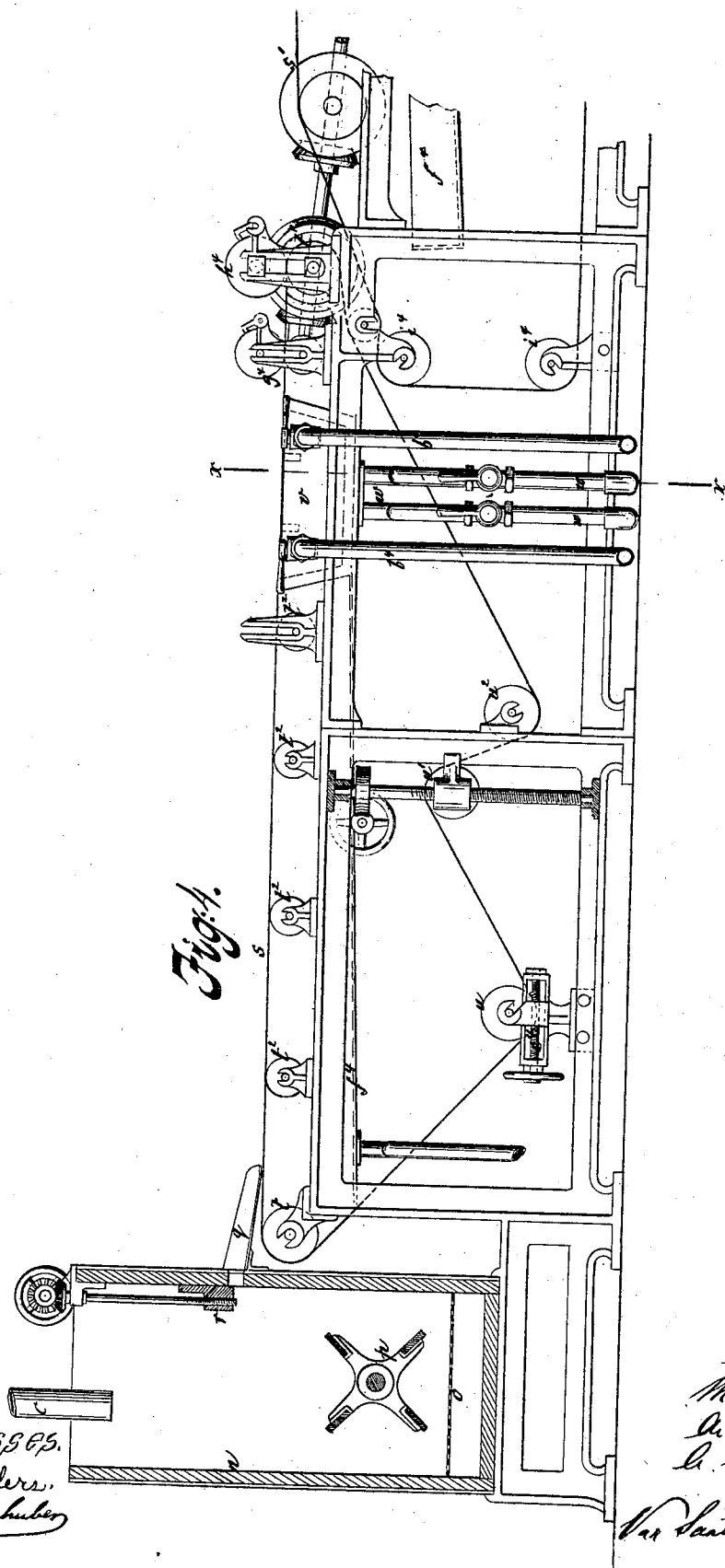

*Fig. 4.*

*Witnesses.*  
*C. Wahler.*  
*E. F. Hattenhuber*

*Inventors.*  
*M. Waissnix*  
*A. Waissnix*  
*C. A. Specker*  
*per*  
*Van Santvoord & Kauf*  
*Dtl.*

M. & A. WAISSNIX & C. A. SPECKER.  
MACHINE FOR PREPARING WOOD PULP.

No. 111,496.

Patented Jan. 31, 1871.

*Fig. 6.*

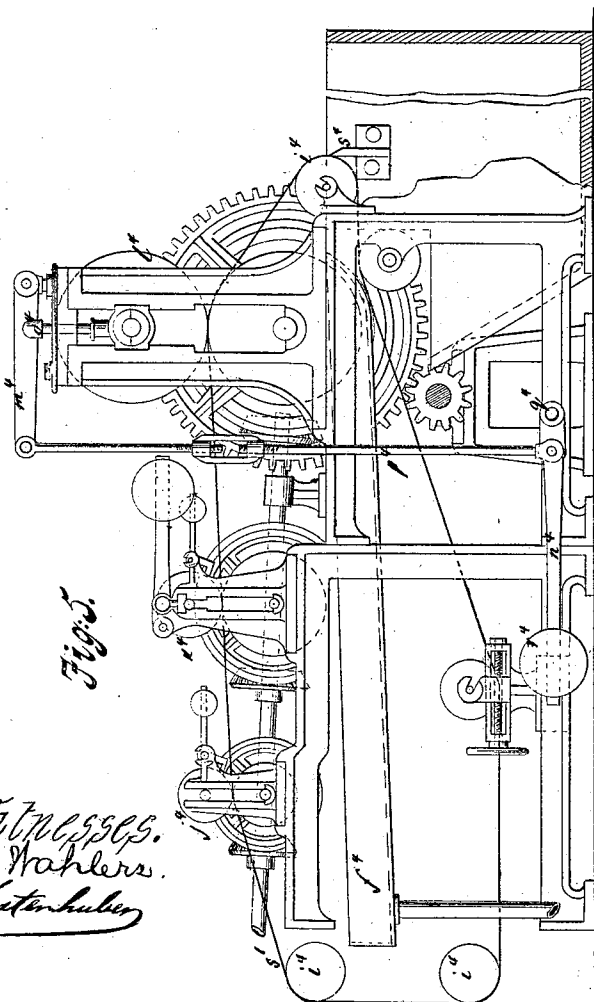
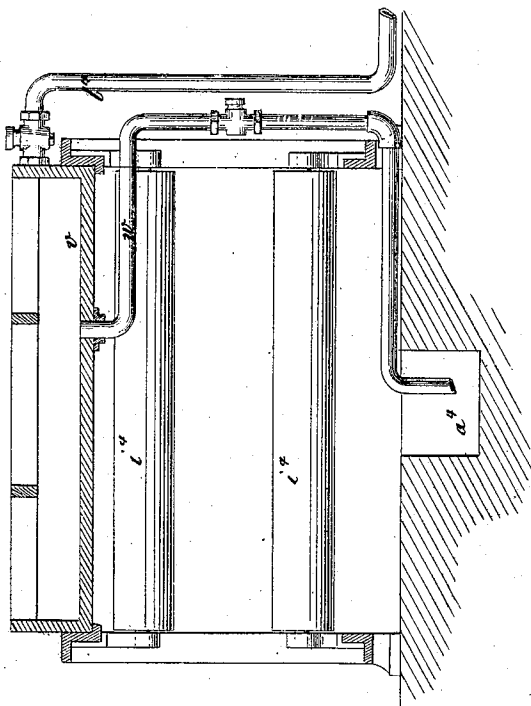

*Fig. 5.*

*Witnesses.*  
*C. Wahlers.*  
*E. F. Kautenhuber*

*Inventors.*  
*M. Waissnix*  
*A. Waissnix*  
*C. A. Specker*  
*Per Laurboord & Haupt Attors*

# United States Patent Office.

MICHAEL WAISSNIX AND ALOIS WAISSNIX, OF REICHENAU, AND CARL A. SPECKER, OF VIENNA, AUSTRIA.

Letters Patent No. 111,496, dated January 31, 1871.

## IMPROVEMENT IN MACHINES FOR PREPARING WOOD PULP.

The Schedule referred to in these Letters Patent and making part of the same.

To all whom it may concern:

Be it known that we, MICHAEL WAISSNIX and ALOIS WAISSNIX, of Reichenau, and CARL A. SPECKER, of Vienna, Austria, have invented a new and useful Improvement in Wood-Pulping Machines; and we do hereby declare that the following is a full, clear, and exact description of the same, reference being had to the accompanying drawing forming a part of this specification, in which drawing—

Figure 1 represents a side view of our machine, showing the position of the various parts of the mechanism in relation to each other.

Figure 2 is a longitudinal vertical section of our assorting mechanism, detached, in a larger scale than the previous figure.

Figure 3 is an end view of the same.

Figure 4 is a side view of the drying mechanism detached, showing one end of this mechanism, the remaining end being represented in fig. 5.

Figure 6 is a transverse section of the same, taken in the plane indicated by the line  $x x$ , fig. 4.

Similar letters indicate corresponding parts.

This invention relates particularly to that part of a wood-pulping machine by means of which the assorted fibers are freed from water and rendered dry enough to be packed up and shipped; and which consists essentially of an endless apron, a series of pressing-rollers and a suction apparatus, by the combined action of which the fibers are freed from water and delivered from the apparatus in a dry state ready to be packed up in bales.

In the drawing—

The letter A, fig. 1, designates a disintegrating mechanism, which may be of the construction described in Letters Patent granted to Henry Voelter August 10, 1858 and May 22, 1866, or it may be of any other suitable construction, this mechanism forming no part of our present invention.

The fibers which are produced by the disintegrating mechanism are conducted, by means of a pipe,  $a$ , to the assorting mechanism B, and thence through a pipe,  $c$ , to the drying apparatus, C, the position of the various parts, in relation to each other, being illustrated in fig. 1 of the drawing.

The assorting mechanism B consists of a series of sieves,  $c c'$ , (see figs. 2 and 3,) which are secured in frames  $h h'$ , the ends of which are supported by transverses  $d e$ , secured in the frames  $f g$ .

The transverses  $d$ , which support the receiving ends of the frames  $h h'$ , are situated somewhat higher than the transverses  $e$ , which support the discharging ends of said frames, so that the sieves will be slightly inclined down toward their discharging ends, as shown in fig. 2.

To the bottom of each of the frames  $h h'$  is secured a shoe,  $i$ , or  $i'$ , and these shoes extend under the sieves  $c c'$ , being inclined in a direction opposite to said sieves, so that the fibers passing through the first sieve are conducted to the highest part of the second sieve, and so on.

The connection between the shoes  $i i'$  and frames  $h h'$  is effected by straps  $j$ , which may be so arranged that they can be shortened or lengthened, for the purpose of increasing or decreasing the inclination of the shoes.

A rapid reciprocating motion is imparted to the frames  $h h'$ , by means of cranks,  $k$ , which connect with said frames by rods  $l$ , or instead of these cranks any other suitable mechanism may be used to produce this motion.

The fibers, which are fine enough to pass through the several sieves, are collected in a vat or box,  $m$ , situated below the lowest sieve, while the coarse particles previously mixed with said fibers pass off over the discharging ends of the sieve.

It must be remarked that the sieves  $c c'$ , instead of being placed one below the other, might be arranged one behind the other, or side by side, locating the second sieve sufficiently lower than the first, the position of the sieves being dependent upon the locality in which the apparatus is to be put up.

It may also be desirable to increase the number of sieves, which can easily be done without making any material change in the construction of this apparatus.

From the vat or box  $m$  of the assorting mechanism the fine fibers, mixed with water, pass through the pipe  $c$  in the box  $n$  of the drying apparatus.

This box may be provided with a false perforated bottom,  $o$ , so that a portion of the water mixed with the fibers can pass off, and in the interior of said box is an agitator,  $p$ , which prevents the fibers from settling down, and causes them to discharge uniformly with the water through the spout  $q$ .

The aperture leading to this spout can be opened or closed by means of a gate,  $r$ , which is operated by suitable mechanism from the top of the box  $m$ , and which serves to regulate the discharge of the fibers and water from the box.

On leaving the spout  $q$  the fibers and water drop upon an endless apron,  $s s'$ , which is, by preference, made of fine wire-cloth, and in two parts, as shown in figs. 1, 4, and 5.

The first part  $s$  of said apron, is stretched over rollers  $t t'$ , and its upper portion is supported by rollers  $t''$ , while the bottom portion thereof passes through under a roller,  $u$ , then over a roller,  $u'$ , then down under a roller,  $u''$ , and up to the roller  $t'$ , best shown in fig. 4.

Between the rollers  $t$  and  $t^1$  is situated the suction-box  $v$ , which is so constructed that the apron  $s$  bears flat on its upper edges, the sagging down of said apron while passing over this box being prevented by cross-bars secured in the box at suitable distances apart, best seen in fig. 6, which represents a transverse section of this part of the drying apparatus.

From the bottom of the box  $v$  extend one or more pipes,  $w$ , down about four or five feet into a well,  $a^1$ , which is filled with water, so that, by the current of water passing down through said pipe, a certain suction is produced, which materially facilitates the separation of the water from the fibers spread over the sieve or apron.

A suitable stop-cock serves to regulate the action of the suction-pipe.

From the upper part of the box  $v$  extend one or more pipes,  $b^1$ , which connect with a suction-blower, so that any air passing through the meshes of the apron into the box  $v$  is removed therefrom, and the effect of the suction-pipe  $a^1$  is thereby increased.

The tension of the apron  $s$  is regulated by the rollers  $u$   $u^2$ , (see fig. 4,) one of which is adjustable by a hand-screw,  $e^1$  in a horizontal, while the other is adjustable in a vertical direction, and the rollers  $t^2$ , which support the upper part of the apron, are placed so close together that no possible sagging down of the apron takes place.

The water which passes through the meshes while the same passes over the supporting rollers  $t^2$ , is collected in a trough,  $f^1$ , secured on the upper part of the main frame, so as to prevent said water from dripping down and wetting the lower portion of the apron.

After having passed the suction-box  $v$  the apron is conducted through between the first roller-press  $g^1$ , and, in passing over the roller  $t^1$ , the pulp in the apron is exposed to the pressure of a roller,  $h^1$ , so that most of the water adhering to the fibers is pressed out.

As the apron  $s$  passes over the roller  $t^1$  the pulp resting thereon is dumped on the second apron  $s^1$ ,

which is stretched over rollers  $t^1$  and passes through between a succession of roller-presses  $g^1$   $h^1$  (see fig. 5.)

All these roller-presses consist of a pair of rollers, the upper roller being so arranged that it bears on the lower one by its own gravity, which may be assisted by a weight and lever, and, in order to be able to increase the pressure as much as may be required, two or more levers,  $m^1$   $n^1$ , may be combined, as shown, on the press  $h^1$ , fig. 5, the levers  $m^1$  being hinged to the tops of the standards forming the guides for the journal-boxes, and bearing on rods  $o^1$ , which extend from said boxes, while their outer ends connect by rods  $p^1$ , with the bottom levers  $n^1$ , which have their fulcrums on pivots  $q^1$ , secured in the main frame, and on the loose ends of which are applied weights  $r^1$ , which may be made adjustable, so that the pressure on the top roller of the press may be increased or decreased, as may be desired.

A scraper,  $s^1$ , best seen in fig. 5, serves to separate the dried fibers from the apron, and these fibers collect in a suitable reservoir ready to be packed. A similar scraper may also be applied at the discharging end of the first apron.

We prefer to use two detached aprons, since it is difficult to manage an apron of very great length; but in some cases a single apron may be used, or the number of aprons may be still further increased.

What we claim as new, and desire to secure by Letters Patent, is—

The drying apparatus for wood pulp, consisting of an endless apron, a suction mechanism, and one or more roller-presses, all constructed and operating substantially in the manner set forth.

This specification signed by us this 30th day of November, 1870.

M. WAISSNIX.  
ALOIS WAISSNIX.  
CARL A. SPECKER.

Witnesses:

WILLIAM HUNING,  
GEO. W. KOROSIN.