

(19) World Intellectual Property Organization
International Bureau



(43) International Publication Date
14 May 2009 (14.05.2009)

PCT

(10) International Publication Number
WO 2009/061481 A1

(51) International Patent Classification:
G01V 3/00 (2006.01)

(21) International Application Number:
PCT/US2008/012592

(22) International Filing Date:
6 November 2008 (06.11.2008)

(25) Filing Language: English

(26) Publication Language: English

(30) Priority Data:
61/002,022 6 November 2007 (06.11.2007) US
61/008,991 21 December 2007 (21.12.2007) US

(71) Applicant (for all designated States except US): **T2 BIOSYSTEMS, INC.** [US/US]; 286 Cardinal Medeiros Avenue, Cambridge, MA 02141-1920 (US).

(72) Inventors; and

(75) Inventors/Applicants (for US only): **PRADO, Pablo, J.** [US/US]; 1 Devonshire Place, Apt. 2110, Boston, MA 02109 (US). **LOWERY, Thomas, J. Jr.**, [US/US]; 85 Beech Street #2, Belmont, MA 02478 (US).

(74) Agents: **WAKIMURA, Mary, Lou et al.**; Hamilton, Brook, Smith & Reynolds, P.C., 530 Virginia Road, P.O. Box 9133, Concord, MA 01742-9133 (US).

(81) Designated States (unless otherwise indicated, for every kind of national protection available): AE, AG, AL, AM, AO, AT, AU, AZ, BA, BB, BG, BH, BR, BW, BY, BZ, CA, CH, CN, CO, CR, CU, CZ, DE, DK, DM, DO, DZ, EC, EE, EG, ES, FI, GB, GD, GE, GH, GM, GT, HN, HR, HU, ID, IL, IN, IS, JP, KE, KG, KM, KN, KP, KR, KZ, LA, LC, LK, LR, LS, LT, LU, LY, MA, MD, ME, MG, MK, MN, MW, MX, MY, MZ, NA, NG, NI, NO, NZ, OM, PG, PH, PL, PT, RO, RS, RU, SC, SD, SE, SG, SK, SL, SM, ST, SV, SY, TJ, TM, TN, TR, TT, TZ, UA, UG, US, UZ, VC, VN, ZA, ZM, ZW.

(84) Designated States (unless otherwise indicated, for every kind of regional protection available): ARIPO (BW, GH, GM, KE, LS, MW, MZ, NA, SD, SL, SZ, TZ, UG, ZM, ZW), Eurasian (AM, AZ, BY, KG, KZ, MD, RU, TJ, TM), European (AT, BE, BG, CH, CY, CZ, DE, DK, EE, ES, FI, FR, GB, GR, HR, HU, IE, IS, IT, LT, LU, LV, MC, MT, NL, NO, PL, PT, RO, SE, SI, SK, TR), OAPI (BF, BJ, CF, CG, CI, CM, GA, GN, GQ, GW, ML, MR, NE, SN, TD, TG).

Published:
— with international search report

(54) Title: SMALL MAGNET AND RF COIL FOR MAGNETIC RESONANCE RELAXOMETRY

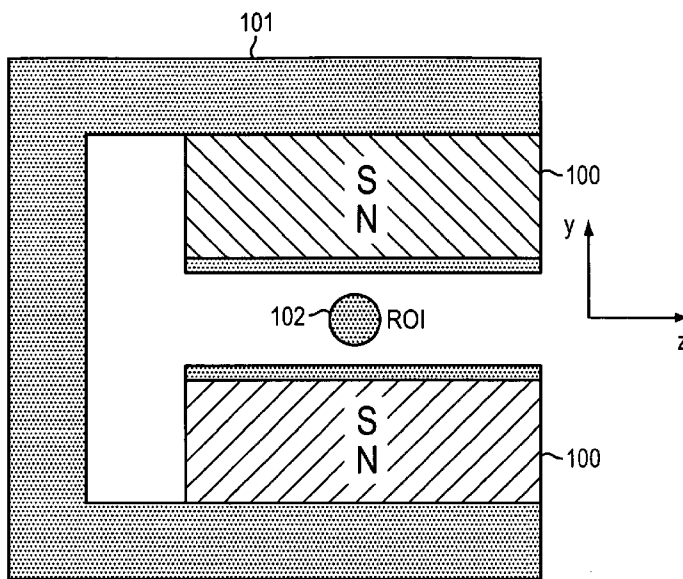

FIG. 1

(57) Abstract: Small and inexpensive probeheads for use in nuclear magnetic resonance systems, in particular, magnetic resonance relaxometry systems are provided. The design of the magnet-radiofrequency coil configurations within the probeheads is guided by an excitation bandwidth associated with radiofrequency pulses to be applied to a sample.



WO 2009/061481 A1

SMALL MAGNET AND RF COIL FOR MAGNETIC RESONANCE RELAXOMETRY

RELATED APPLICATIONS

This application claims priority to and the benefit of U.S. Provisional
5 Application No. 61/002,022, filed November 6, 2007; and this application claims
priority to and the benefit of U.S. Provisional Application No. 61/008,991, filed
December 21, 2007. The entire contents of the prior applications are incorporated
herein by reference in their entirety.

BACKGROUND OF THE INVENTION

10 Nuclear magnetic resonance (NMR) systems make use of nuclear magnetic
resonance of atomic nuclei contained in a sample and are known to be able to
provide a large variety of information characterizing the sample and corresponding
sample components. Systems include, for example, magnetic resonance imaging
(MRI) devices, magnet resonance spectrometers and magnetic resonance
15 relaxometers. The nature of the nuclear magnetic resonance phenomenon requires
the presence of a magnetic field upon excitation with a radiofrequency
electromagnetic wave. Thus, generally, NMR systems include a magnet and a
radiofrequency coil, either as separate system components or combined in a
probehead.

20 Magnets that are preferred in magnetic resonance systems provide magnetic
fields with high magnetic field strength and high homogeneity. Magnets known to
satisfy these requirements are typically large and/or expensive. They are therefore
not suitable for portable devices and/or implantation devices, and/or not suitable as
part of disposable probeheads. Thus, a need exists for small, inexpensive probeheads
25 for use in magnetic resonance systems, allowing portability, implantation and/or
one-time use applications.

SUMMARY OF THE INVENTION

5 Provided probeheads and methods of preparing the same solve the problems of the current MR systems relating to portability, potential implantation and/or disposability of probeheads for use in MR systems. Probeheads provided in the present invention are particularly suitable, though not limited to, magnetic resonance relaxation measurements.

10 One embodiment is a small probehead for use in a magnetic resonance relaxometer. The probehead comprises (a) at least one magnet or magnetic field generator providing a magnetic field, (b) a space capable of accommodating a sample volume having an associated excitable volume, and (c) a radiofrequency coil having an associated detection volume, the radiofrequency coil being adapted and positioned such that its detection volume overlaps at least partly with an excitable volume. The provided magnetic field is inhomogeneous, and the space
15 accommodating the sample volume and the radiofrequency coil are adapted and positioned according to a radiofrequency pulse optimized for the magnetic field distribution corresponding to the position of the sample volume. A provided probehead is optimized to obtain relaxometry parameters from a sample contained in the detection volume..

20 Another embodiment of is a probehead for magnetic resonance relaxometry. A small probehead comprises (a) two magnets or two magnetic field generators attached to a yoke, the south pole surface of one of the magnets or magnetic field generators opposing the north pole surface of the other magnet or magnetic field generator to form a gap between the magnets or magnetic field generators and to
25 provide a magnetic field in the gap, (b) a space capable of accommodating a sample volume having an associated excitable volume, and (c) a radiofrequency coil within the gap, the radiofrequency coil having an associated detection volume and being adapted to emit a radiofrequency pulse with a pulse length, the radiofrequency coil being positioned and designed to have the detection volume partly overlap with an
30 excitable volume within the gap. The provided magnetic field is inhomogeneous. Additionally, the space accommodating the sample volume and the radiofrequency

coil are adapted and positioned according to a radiofrequency pulse bandwidth optimized for the magnetic field distribution corresponding to the position of the sample volume. The probehead is thus optimized to obtain relaxometry parameters from a sample contained in the sample volume.

5 Additionally provided are methods for preparing probeheads for use in a magnetic resonance relaxometry. In one embodiment is a method for preparing a probehead for use in a magnetic resonance relaxometer. The method comprises the steps of (a) providing at least one magnet or magnetic field generator providing a magnetic field, (b) providing a radiofrequency coil, (c) positioning the
10 radiofrequency coil to have its associated detection volume overlap at least partly with an excitable volume, (d) positioning a space capable of accommodating a sample volume having an associated excitable volume; and (e) adapting the space for the sample volume and the radiofrequency coil according to a radiofrequency pulse optimized for the magnetic field distribution corresponding to the position of
15 the detection volume. The probehead is thus optimized to obtain relaxometry parameters from a sample contained in the sample volume.

A further embodiment is a method of preparing a small probehead for use in portable magnetic resonance relaxometry. The method comprises the steps of (a) attaching two magnets or two magnetic field generators to a yoke such that the south
20 pole surface of one of the magnets or magnetic field generators opposes the north pole surface of the other magnet or magnetic field generator to form a gap between the magnets or magnetic field generators and to provide a magnetic field in the gap, (b) positioning a space capable of accommodating a sample volume having an associated excitable volume, and (c) positioning a radiofrequency coil within the
25 gap, the radiofrequency coil having an associated detection volume and being adapted to emit a radiofrequency pulse with a pulse length, the radiofrequency coil being positioned and designed to have the detection volume at least partly overlap with an excitable volume within the gap. The probehead is thus optimized to obtain relaxometry parameters from a sample contained in the sample volume.

30 The foregoing will be apparent from the following more particular description of example embodiments of the invention, as illustrated in the accompanying drawings in which like reference characters refer to the same parts

throughout the different views. The drawings are not necessarily to scale, emphasis instead being placed upon illustrating embodiments of the present invention.

BRIEF DESCRIPTION OF THE DRAWINGS

5 FIG. 1 provides a schematic representation of a probehead including a c-shaped yoke with magnets attached thereto and a radiofrequency coil placed between the magnets.

 FIG. 2 shows a probehead employing two NdFeB permanent magnets and a ten-turn radiofrequency coil from two sides.

10 FIG. 3 shows the "T2-yoke" made from a steel yoke and 1"x 1"x 0.5" NdFeB magnets.

 FIG. 4 shows a Halbach magnet positioned on a field mapping apparatus with a gaussmeter probe positioned within the center gap.

 FIG. 5 provides a schematic representation (side view and front view) of a
15 probehead including a c-shaped yoke with magnets attached thereto and a radiofrequency coil placed between the magnets.

 FIG. 6 shows the measured dependency of the magnetic field strength along three directions (along the gap, across the gap, and from bottom to top) within the gap between the magnets of the probehead shown in FIG. 2.

20 FIG. 7 provides a shaded field map within the center gap of a theoretical model magnet.

 FIG. 8 provides a relaxation decay curve of a nanoparticle assay measured using the magnet and probehead in FIG. 2. A solution of magnetic relaxation switch nanoparticles sensitized to the protein β -hCG was used to detect a concentration of
25 65 nM (or 1 microgram/mL) hCG in 0.4 microliters of pH 7.4 PBS buffer.

 FIG. 9 shows the measured dependency of the magnetic field strength along three directions (along the gap, across the gap, and from bottom to top) within the gap between the magnets or within the center gap of the T2-yoke magnet (shown in FIG. 3) and the Halbach magnet (shown in Figure 4) respectively. Examples of
30 determining the region that can be excited for each dimension are shown with the dashed-line boxes.

FIG. 10 shows the radiofrequency coil resonant circuit for the Halbach magnet.

FIG. 11 shows the radiofrequency coil resonant circuit for the T2-yoke.

5 DETAILED DESCRIPTION OF CERTAIN EMBODIMENTS OF THE INVENTION

Probeheads of the present invention include a magnet and/or magnetic field generator and at least one radiofrequency coil, and are much smaller and much less expensive than conventional combinations of magnet(s) and radiofrequency coil(s).

10 Weight and size of a probehead are critical factors for portable MR instruments. For example, weight and size reduction has implications in regards to system development and manufacturing, cost, and placement. Small probes may be, e.g., implantable in-vivo devices, embedded sensors for material testing, and sensors for on-line process monitoring. Additionally, because they are inexpensive provided small probeheads may be used in applications that benefit from disposable
15 probeheads.

One aspect of the present invention is the scalability of a Magnetic Resonance (MR) probehead comprising a magnet and a radio-frequency (RF) coil. In particular, the present invention addresses the issue of significantly reducing size of probehead components while allowing measurement of magnetic resonance signal
20 level(s), and, in particular, magnetic resonance relaxation parameter(s) and time(s). Designing a probehead specifically for relaxometry instead of conventional MR spectroscopy, allows for a dramatic reduction in its size and cost.

Magnet configuration and yoke design, if desired, can be accomplished initially by a theoretical prediction of what magnet and yoke configuration will lead
25 to in terms of magnetic field strength. Suitable magnetic field strength will be discussed below. This can be done using standard analytical methods known in the art.

In one embodiment at least one magnet or magnetic field generator is shaped and/or configured to provide the magnetic field in a gap. In certain embodiments, a
30 radiofrequency coil is positioned, either partly or completely within the gap of such a configuration.

For a given magnet configuration, for example, two opposing permanent magnets as presented schematically in Figure 1 and shown in Figures 2 and 3, and a Halbach magnet as shown in Figure 4, the magnetic field in the x, y, and z directions can be determined using standard methods known in the art, for example, by fixing a
5 gaussmeter probe relative to the magnet and moving the magnet in incremental steps with a three axis stage while recording the field strength as a function of position to obtain a field map.

Given knowledge of the magnetic field, for example, in terms of a calculated or measured magnetic field map and a pulse length of a radiofrequency pulse to be
10 used in relaxation measurements, a radiofrequency coil or radiofrequency coil array can be designed and concurrently a proper position for the same be determined. Pulse length and excitation bandwidth are inversely related. For example, a 2 μ s pulse corresponds to a 500 kHz excitation bandwidth (see below for more details). The excitation bandwidth can be used to calculate: 1) for a given sample volume, the
15 necessary magnetic field homogeneity to be able to excite part of or an entire sample volume, and/or 2) for a given magnet or magnet array, the volume that is excitable with a radiofrequency pulse of a given pulse length in the presence of the magnetic field of the given magnet or magnet array.

Typically, a given excitation bandwidth dictates a requisite magnetic field
20 homogeneity. Once a magnet is designed to create limited homogeneity of a volume that is suitable or desirable for a sample (e.g., which may be dictated by fluidics or specimen size of a sample), a coil is designed to excite a complete volume of excitable spins of a sample volume. Thus, according to the present invention, an excitation bandwidth appropriate for a magnet configuration guides the magnet and
25 coil design as well as the probehead configuration design.

A probehead of the present invention includes (a) at least one magnet or magnetic field generator providing a magnetic field; (b) a space capable of
accommodating a sample volume having an associated excitable volume; and (c) a
30 radiofrequency coil having an associated detection volume, the radiofrequency coil being adapted and positioned such that its detection volume overlaps at least partly with the excitable volume. The magnetic field provided by the magnet or magnetic field generator is inhomogenous. The space accommodating the sample volume and

the radiofrequency coil are adapted and positioned according to a radiofrequency pulse bandwidth optimized for a magnetic field distribution corresponding to the position of the sample volume. The probehead is thus optimized to obtain relaxometry parameters from a sample contained in the detection volume.

5 An “excitable volume” as used herein is a volume of hydrogen nuclei of water within a sample volume which are transitioned to a higher energy state by a radiofrequency pulse of a given pulse length in the presence of a magnetic field provided by a magnet and/or magnet field generator.

10 All atomic nuclei with an odd atomic mass or an odd atomic number (like hydrogen nuclei of water for example) possess an intrinsic nuclear magnetic momentum. When such atomic nuclei are placed in a static magnetic field, this momentum can take at least two different orientations. For spin $\frac{1}{2}$ nuclei, such as ^1H the momentum may take either a parallel or anti-parallel orientation relative to the magnetic field. Considering a population of hydrogen nuclei immersed in the same
15 static magnetic field, the number of nuclei having a parallel orientation is slightly greater than the number of nuclei having an anti parallel orientation (a ratio of 1,000,003: 1,000,000 at fields of 0.5 T and room temperature). This is due the fact that the parallel orientation is only slightly more energetically favorable. Transitions
20 from a parallel state to an anti-parallel state occur when nuclei absorb electromagnetic energy at a given frequency called a resonance frequency, which is dictated by the strength of the magnetic field. Typically, hydrogen nuclei in different locations in a magnetic field experience different magnetic field strengths and therefore have different resonance frequencies required for excitement. Therefore, in prior systems, a range of frequencies were necessary to sufficiently
25 excite a significant portion of hydrogen nuclei in a sample and generate effective relaxation readings. A given pulse length produces a corresponding excitation bandwidth that, at a given magnetic field, excites a volume of hydrogen nuclei with a radiofrequency pulse. The resulting signal after excitation can be detected via typical methods known in the art.

30 In one embodiment, a RF coil included in a probehead of the present invention is adapted to provide pulse lengths between about 0.4 μs and about 10 μs . Typically, a pulse length of between about 0.5 μs and about 4 μs is used. More

typically, a pulse length of between about 1 μ s and about 4 μ s is used. Even more typically, a pulse length of between about 1 μ s and about 3 μ s is used.

A "probehead" as used herein is a sensing or probing device of a nuclear magnetic resonance system. A probehead may be implanted, partially or
5 completely, in a mammal's body. Typically, a probehead of the present invention includes (a) at least one magnet and/or magnetic field generator providing a magnetic field, and (b) a radiofrequency coil having an associated detection volume, and the radiofrequency coil being positioned such that its detection volume overlaps at least partly with an excitable volume..

10 In one embodiment, a probehead comprises a space capable of accommodating a sample volume and/or a port. In certain embodiments, a space capable of accommodating a sample volume and port can be, for example, a radiofrequency coil (as part of a radiofrequency circuit) wound to enclose a sample volume while providing an opening (i.e., space capable of accommodating a sample
15 volume) to allow a sample volume to be placed within the opening. In other embodiments, a space capable of accommodating a sample volume and/or port is distinct from the opening of a radiofrequency coil but adapted to a given radiofrequency coil, for example, formed to enclose part or all of a detection volume of the radiofrequency coil. For example, a glass capillary within a radiofrequency
20 coil.

In some embodiments a radiofrequency coil is wound to enclose a volume of less than about 500 μ l. In certain embodiment a radiofrequency coil is wound to enclose a volumes of less than about 100 μ l. In still other embodiments a radiofrequency coil is wound to enclose a volume of less than about 10 μ l are used.
25 In still further embodiment a radiofrequency coil is wound to enclose a volume of less than about 5 μ l. In particular embodiments a radiofrequency coil is wound to enclose a volume of less than about 1.6 μ l. In still further particular embodiments a radiofrequency coil is wound to enclose a volume of less than about 0.4 μ l.

Also, for implantable probeheads, typically, material used to form a sample
30 volume, and, in particular, any material that may be in contact with a biological sample or tissue is typically biocompatible, that is constructed of materials that allow for proper function of both the device and a host animal's biological functions

and/or coated with a physiologically acceptable coating as known in the art to render the implantable bioinert, biomimetic, or bioactive, as desired. Suitable materials include titanium, inert silicone elastomers, ceramics, glass, polymeric materials, poly- β -hydroxybutyrate (PHB) and the like. One or more sample volumes and
5 corresponding ports can be fabricated using methods known in the art. Suitable methods include form or injection molding methods, and microfabrication methods for sample containers smaller than a few millimeter, for example, two-photon three-dimensional lithography. A probehead may contain a "housing" that encloses the components of the probehead such as, for example, a radiofrequency coil and
10 magnet. In certain embodiments at least one component of a probehead (e.g., a magnet, a magnetic field generator, a radiofrequency coil) is attached to the housing.

A "port" as used herein, refers in the simplest case to an opening as provided above, but can also be a structure or device that is adapted to selectively allow
15 analytes or reagents to enter and/or exit the sample volume.

In certain embodiments, a probehead includes one or more separate sample volumes. In some embodiments a probehead includes between about 1 and about 100 sample volumes. In some embodiments a probehead includes between about 1 and about 10 sample volumes. In some embodiments a probehead includes two
20 sample volumes. In certain embodiments a probehead includes one sample volume.

A probehead containing more than one sample volume may comprise a radiofrequency coil with an associated detection volume encompassing at least part of each sample volume. Alternatively, a probehead may have more than one radiofrequency coil and/or radiofrequency circuit, one for each sample volume or a
25 subgroup of the sample volumes. In certain embodiments, a probehead comprises at least two radiofrequency coils. Also, a probehead of the systems of the present invention can include a magnet or magnetic field generator as discussed above.

For probeheads that include a plurality of separate sample volumes but only one radiofrequency coil that is employed to probe the plurality of sample volumes
30 simulatenously, multiplexing methods may be used to distinguish the magnetic resonance signal or information from the separate sample chambers. For example, one multiplexing method that may be used is based on extracting decay constant

values, for example, values of spin-spin relaxation constant T_2 from multi-exponential relaxation curves (see T.J. Lowery *et al.*, *Anal. Chem.* (2008), *80*, 1118-1123.). Relaxation data obtained using a probehead of the present invention may be fit to a decaying exponential curve defined by the following equation:

$$5 \quad f(t) = \sum_{i=1}^n A_i \exp\left(-t/T(i)\right)$$

where $f(t)$ is the signal intensity as a function of time, t , A_i is the amplitude coefficient for the i th component, and $(T)_i$ the decay constant (such as T_2) for the i th component. For relaxation phenomenon discussed here the detected signal is the sum of a discrete number of components ($i=1,2,3,4\dots n$). Such functions are called
10 mono-, bi-, tri-, tetra- or multi-exponential, respectively. Due to the widespread need for analyzing multi-exponential processes in science and engineering, there are several established mathematical methods for rapidly obtaining estimates of A_i and $(T)_i$ for each coefficient (Istratov, A. A. & Vyvenko, O. F. 1999. Exponential analysis in physical phenomena. *Rev. Sci. Inst.* 70 (2): 1233-1257).

15 A "magnet" as used herein can be any material or combination of materials that provides a magnetic field in at least some volume around the material. Typically, the magnet is a permanent magnet. Suitable, materials include but are not limited to NdFeB, FeCo, and the like. Magnets can be configured to form new magnets, that is, magnet arrays, for example, a permanent magnet with a c-shaped
20 yoke, a Halbach magnet (cylinder and other configurations), u-magnet, torroidal magnet and the like.

The magnets, magnet configurations and magnetic field generators of the present systems can be weak and/or provide magnetic fields that are inhomogeneous. Typically, maximum magnetic field strength values provided by
25 the magnets and/or magnet configurations of the present invention are between about 0.2 Tesla and about 2 Tesla. More typically, they are between about 0.3 and about 1.5 Tesla. Even more typically, they are between about 0.4 and about 1.1 Tesla. Even more typically, they are between about 0.2 and about 1.1 Tesla. Even more typically, they are between about 0.2 and about 0.8 Tesla. Most typically, they
30 are between about 0.45 and 0.85 Tesla. In some embodiments the magnetic field strength is less than about 2 Tesla. In certain embodiments the magnetic field

strength is less than about 1.1 Tesla. In certain embodiments the magnetic field strength is less than about 0.8 Tesla.

The term “inhomogeneous” refers to magnetic fields that are lower in uniformity than those required for spectroscopy. Homogeneity is dependent on the space in which the measurement is defined. For the instant applications,
5 homogeneities of the magnetic fields can range between about 10000 ppm and about 10 ppm. In some embodiments homogeneities can range between about 50 ppm and 5000 ppm. In particular embodiments homogeneities can range between about 100 ppm and about 1000 ppm.

10 Also, typically, magnetic fields employed in the present systems are effectively static, that is, they do not change substantially over time. Changes in magnetic field such as due to temperature fluctuations are considered to be not substantial.

Small probeheads of the present invention can be used for, but are not
15 limited to *in-vivo* magnetic resonance measurements. Small probeheads for complete implantation within a mammal’s body, preferably have small magnets to lessen the invasiveness of the implantation. Typically, magnets for implantation are smaller than about 2 inches in any dimension. More typically, magnets for implantation are smaller than about 1 inch in any dimension. Most typically,
20 magnets for implantation are smaller than about 0.5 inches in any dimension.

The probeheads of the present invention can also be used *in-vitro*, for example, as part of small and/or portable magnetic resonance systems. Typically, magnets in probeheads for these systems are smaller than about 2 inches in any dimension. More typically, they are smaller than about 1 inch in any dimension.
25 Most typically, they are smaller than about 0.5 inches in any dimension. Each dimension may be independently determined.

A “magnetic field generator” as used herein, is a device that provides a magnetic field in at least some volume around the device. Typically, a magnetic field generator requires a power supply and provides the targeted magnetic field
30 only when powered. Examples of magnetic field generators include but are not limited to electromagnets with and without a metal pole (see Cardot et al Sensors and Actuators 1994).

Probeheads using magnetic field generators can be implanted in a mammal's body. However, because magnetic field generators tend to be larger than magnets, and they are more complex, for example, require a power supply, more typically, probeheads using magnetic field generators are used for disposition outside a
5 mammal's body.

The magnet(s) and magnetic field generator(s) in the present systems are selected and positioned to provide a magnetic field of sufficient strength in the sample volume to allow measuring magnetic resonance signals. The magnetic field strength of a given magnet or magnetic field generator in a given volume, for
10 example, a sample volume can be calculated and/or approximated using methods known in the art. Typically, the magnetic field strength depends on the nature of the magnet or magnetic field generator and the position of the magnet or magnetic field generator relative to the sample volume. Also, magnetic field strength of a given
15 magnet or magnetic field generator in a sample volume can be measured using methods and devices known in the art, for example, gaussmeters, teslameters, hall effect probes, and the like. Typically, magnetic field strengths within a sample volume of between about 0.2 and about 2 Tesla are sufficient to allow measuring magnetic resonance signals. More typically, magnetic field strengths within the
20 sample volume of between about 0.2 and about 1 Tesla are sufficient to allow measuring magnetic resonance signals. Even more typically, magnetic field strengths within the sample volume of between about 0.2 and about 0.8 Tesla are sufficient to allow measuring magnetic resonance signals. Most typically, magnetic field strengths within the sample volume of between about 0.3 and about 0.65 Tesla are sufficient to allow measuring magnetic resonance signals.

25 The magnets and magnetic field generators suitable for the probeheads of the present invention are not limited to any particular size. However, in particular, for implantable and handheld probeheads small magnets are desired. Typically, each of the at least one magnet or magnetic field generator of the probeheads of the present invention is in any dimension less than about one two inches. More typically, each
30 of the at least one magnet or magnetic field generator is in any dimension less than about 1 inch. Most typically, each of the at least one magnet or magnetic field generator is in any dimension less than about 0.5 inch.

Probeheads of the present invention may be used to sense/measure magnetic resonance signals as part of a magnetic resonance system with sensing reagents enclosed within the probehead, and, in particular, within one or more sample volume.

5 A “sensing agent” as used herein is an agent that senses, responds to or is influenced by a sample characteristic to correlate the presence and/or extent of the sample characteristic with the presence, change or magnitude of the magnetic resonance signals associated with the sample. The term “sample characteristic” as used herein refers to any chemical and/or physical property of a given sample.

10 Suitable sample characteristics can be, but are not limited to concentration of an analyte (that is, a molecule, ion, or radical of interest in the sample), pH-value, ionic strength, hydration state (e.g., of tissue or biofluids, that is, concentration of water in tissue or biofluids), temperature, and the like.

 Suitable sensing agents can be, but are not limited to dry reagent
15 compositions, magnetic particles, responsive polymers, magnetic resonance contrast agents, and the like.

 Dried reagent compositions that are suitable include, for example, dried biotinylated coated nanoparticles (see T.J. Lowery *et al.*, *Anal. Chem.* (2008), *80*, 1118-1123), for example, based on the following formulation (216 μ L, 0.083 mM
20 Fe, 10 mM PBS, 20 mg/ml dextran, pH 7.4). Dried reagent compositions can be prepared by placing a magnetic particle solution, for example, biotinylated coated nanoparticle solution into a container, for example, a container such as a glass tube, and freezing the container in a freeze dryer (e.g., VirTis freeze dryer (Gardiner, NY)), for example, at -80°C for 24h. Each of the one or more separate volumes of
25 the sample containers may be filled by transfer of the dried reagent composition from the container that was used during freeze drying.

 “Magnetic particles” as used herein, are particles that respond to or are influenced by a sample characteristic to correlate the presence and/or extent of the sample characteristic with the presence, change or magnitude of the magnetic
30 resonance signals associated with the sample. Typically, the magnetic particles respond by aggregating. Also, typically, magnetic particles have an average particle size of between about 1 nm and 5 μ m. Magnetic particles may be paramagnetic or

superparamagnetic. They can have binding moieties on their surface. The binding moieties are preferably operative to alter the aggregation of the magnetic particles as a function of the presence or concentration of the analyte. The magnetic particles may include an oxide and/or a hydroxide of Fe, Si, Sn, An, Ti, Bi, Zr, and/or Zn.

5 The magnetic particles are preferably superparamagnetic and have crystallite size from about 1 nm to about 100 nm. The magnetic nanoparticles preferably have a metal oxide core of about 1 to about 25 nm, from about 3 to about 10 nm, or about 5 nm in diameter. The binding moieties may include one or more species of one or more of the following: an amino acid, a nucleic acid, an oligonucleotide, a
10 therapeutic agent, a metabolite of a therapeutic agent, a peptide, a polypeptide, a protein, a carbohydrate, a polysaccharide, a virus, and/or bacteria. For example, in one embodiment, the binding moieties may include one, two, or more types of oligonucleotides and/or one, two, or more types of proteins. The binding moieties may be a polymer, or may be part of a polymer that is linked to, or otherwise
15 associated with one or more of the magnetic particles. The binding moieties preferably include functional groups, for example, the binding moieties may include one or more species of one or more of the following: an amino group, a carboxyl group, a sulfhydryl group, an amine group, an imine group, an epoxy group, a hydroxyl group, a thiol group, an acrylate group, and/or an isocyanate group.

20 The analyte may include one or more species of one or more of the following: a protein, a peptide, a polypeptide, an amino acid, a nucleic acid, an oligonucleotide, a therapeutic agent, a metabolite of a therapeutic agent, RNA, DNA, an antibody, an organism, a virus, bacteria, a carbohydrate, a polysaccharide, and glucose. The analyte may also include, for example, a lipid, a gas (e.g., oxygen,
25 carbon dioxide), an electrolyte (e.g., sodium, potassium, chloride, bicarbonate, BUN, creatinine, glucose, magnesium, phosphate, calcium, ammonia, lactate), a lipoprotein, cholesterol, a fatty acid, a glycoprotein, a proteoglycan, and/or a lipopolysaccharide.

For example, magnetic particles can be adapted to respond to glycosylated
30 hemoglobin. For example, amino-CLIO nanoparticles, that is, iron oxide nanoparticles coated with amino-functionalized cross-linked dextran, may be decorated with boronate compounds by standard solution-phase chemistries. The

boronate compounds such as boronic acid, phenylboronic, boric acid and boronate, etc. have an affinity for HbA1c, a specific type glycated hemoglobin designated based on its separation from other species of glycated hemoglobin.. Hemoglobin is composed of four subunits, two α chains and two β chains therefore HbA1c is

5 divalent. The divalency allows HbA1c to facilitate the boronic acid functionalized superparamagnetic iron oxide particle agglomeration. Boronate reacts with HbA1c in a sample through the cis-diol moiety of glucose bound to hemoglobin, forming a five-membered ring structure. A boronate group can be attached to a solid phase covalently or electrostatically by a variety of chemistries. Solid phases such as

10 amino-CLIO nanoparticles can be decorated with boronate compounds by standard solution-phase chemistries. Amino-CLIO are iron oxide nanoparticles coated with amino-functionalized cross-linked dextran. The dextran polymer coating endows these nanoparticles with solubility and enabled solution-phase chemistries. Suitable boronate compounds include but are not limited to 4-carboxyphenylboronic acid, 3-

15 nitro-5-carboxyphenylboronic acid, and m-aminophenylboronic acid (APBA).

“Nanosensors” are paramagnetic or superparamagnetic magnetic particles, typically of nanometer scale, that comprise a polymer matrix layer about a magnetic core and/or are derivatized/functionalized with binding moieties or affinity groups for a target compound or analyte. Suitable nanosensors include responsive polymer-

20 coated magnetic nanoparticles. These nanosensors can exploit the ability of magnetic nanoparticles to dephase nuclear spins detectable by nuclear magnetic resonance (NMR), hereinafter generally exemplified as the protons of water molecules, for detection without aggregation of nanoparticles. Each nanoparticle has a polymer matrix layer which expands or contracts when exposed to an analyte

25 and/or condition to be detected. The resulting change in nanoparticle size affects the dephasing of freely-diffusing water molecules in the vicinity of the nanoparticles, which affects one or more NMR-detectable properties. By calibrating the NMR-detected properties with known reference samples, the existence of the condition and/or analyte of interest may be detected in test samples via NMR techniques using

30 the probeheads of the present invention.

In the case where the detected nuclei are water protons, the polymer matrix preferably takes the form of a stimuli or molecule sensitive hydrogel comprising a

polymer “mesh” that is cross-linked by binding moieties that affects the volume, permeability and the proton content of the matrix as a function of a physical or chemical stimulus or a physical parameter of the analyte under study. This is accomplished by design of the matrix as a hydrophilic polymer network comprising
5 (as pendent groups or as part of the polymer backbone) binding moieties that influence water permeability (and/or permeability of other molecules in the environment) through formation of one or more covalent or hydrogen bonds, van der Waals interactions, or physical entanglement with a component of the analyte. The presence of analyte induces a change in the crosslink density of the polymer, which
10 leads to a change in the volume fraction of the solution occupied by the polymer. The change in cross link density also leads to a change in the diameter of the nanoparticles, which leads to a change in their diffusion time. Both diffusion time and specific volume are proportional to the T_2 relaxivity observed for a solution, as shown in the proportionality:

$$15 \quad 1/T_2 \propto (V_p)(R^2/D)$$

where V_p is the specific volume fraction of the particles in solution, R the radius of the particles, and D the diffusion constant of water. The term R^2/D is equal to the diffusion time, τ_d . This is the time necessary for a water molecule to diffuse past a particle, and is proportional to the extent of T_2 relaxation that occurs.

20 The binding moiety may be a chemical binder, an electroactive mediator, an electron-pair donor, and/or an electron-pair acceptor. It may contain an amino, carboxyl, sulfhydryl, amine, imine, epoxy, hydroxyl, thiol, acrylate, or isocyanate group, or a mixture thereof. For example, the binding moiety may be an acetic acid moiety such as in poly(acrylic acid) for sensing pH, or phenylboronic acid for
25 sensing the presence of diols, such as glucose. Alternatively, the binding moieties are binding pairs, or binding pendants, such as antibodies that serve as cross-linkers in the presence of their cognate antigen, or antigens that serve as cross-linkers in the presence of their cognate antibodies, and which mediate the water proton flux in and out of the matrix and change in specific volume by competitive affinity reactions.
30 This typically is accomplished as the extent of cross-linking of matrix polymer is mediated as a function of the physical parameter under study so as to control the permeability of water, including its amount and rate of translational diffusion in an

out of the matrix and within the matrix volume in proximity to the magnetic particle(s). For example, the binding pairs may be a ligand binding protein such as concanavalin A bound to a low-affinity ligand such as a carbohydrate. Addition of glucose to this system would displace the low affinity ligand and change the crosslinking of the matrix. Another example is a matrix-immobilized antibody, antibody fragment, or peptide that crosslinks the matrix by binding to its matrix-immobilized antigen or target. The presence of a higher affinity analyte would lead to disruption of the cross-linked matrix and a swelling of the matrix.

The responsive matrix may comprise a matrix of material which includes one or more monomers and/or polymers. The one or more monomers and/or polymers contains functional groups that enable the binding moiety to be attached to or otherwise in stable association with the nanoparticle to form the conjugate. The polymer can be a natural polymer, a synthetic polymer, a combination of natural and synthetic polymers, shape memory polymers, block co-polymers (PEO, PPO), or derivatives of each type. For example, the matrix polymer may be poly (N-isopropylacrylamide). The matrix polymer may also be (or include), for example, Poly(N-isopropylacrylamide) (PNIAAm), Poly(N,N-diethylacrylamide) (PDEAAm), P(NIAAm-co-BMA), PEO-PPO-PEO (e.g., Pluronic®), N,N-diethylaminoethyl methacrylate (DEA), 2-hydroxypropyl methacrylate (HPMA), Poly-(methacrylic acid-g-ethylen glycol), Poly(2-glucosyloxyethyl methacrylate), Poly(N-vinyl-2pyrrolidone – co – 3-(acrylamido)phenylboronic acid), and/or N-(S)-sec-butylacrylamide. The functional groups can be any appropriate chemical functional group, e.g. carboxy, amino, or sulfhydryl groups. A specific moiety or moieties may be attached to the nanoparticle via conjugation to these groups, or by physical adsorption and/or through hydrogen bonds or van der Waals interactions. The responsive polymer matrix, through physical and/or chemical stimuli, mediates the specific volume of the polymer layer, leading to a detectable change in NMR-measurable properties such as T_2 relaxivity.

“Responsive polymers” (also referred to herein as “smart polymers”) are polymers that are, for example, sensitive to pH, ionic strength, and specific molecular and biomolelar analytes. In these cases the hydration level, cross-link density, or other characteristic of the polymer changes in response to a changes in

the sample, for example, biofluid. This change in polymer state leads to changes in the magnetic resonance signals that can be detected by an implanted radiofrequency coil. Suitable smart polymers are known in the art, and described, for example, in Gemeinhart, RA, Chen, J, Park, H, Park, K. 2000. pH-sensitivity of fast responsive superporous hydrogels. *J. Biomater. Sci. Polym. Ed.* 11: 1371-1380; Murakami, Y, Maeda, M. 2005. DNA-responsive hydrogels that can shrink or swell. *Biomacromolecules*, 6: 2927-2929; Miyata, T, Uragami, T, Nakamae, K. 2002. Biomolecule-sensitive hydrogels. *Adv Drug Deliv Rev*, 54: 79-98; and Zhang, R, Bowyer, A, Eisinger, R, Hubble, J. 2006. A smart membrane based on an antigen-responsive hydrogel. *Biotechnol Bioeng*.

Probeheads of the present invention include a radiofrequency coil.

A “radiofrequency coil” as used herein is a coil that is suited to sense and/or detect magnetic resonance signals in an associated detection volume, and, optionally, also allows to apply/emit radiofrequency pulses with associated pulse length(s) to a sample under investigation with the probehead as part of a magnetic resonance system. Suitable radiofrequency coil types include planar coils and “whole volume” coils such as might be constructed of opposed saddle coils, solenoids, Helmholtz coils and the like. Typically, the probeheads employed in the systems of the present invention include solenoids.

“Detection volume” as used herein refers to a volume associated with a given radiofrequency coil from which magnetic resonance signals, in principle, are detectable with the given radiofrequency coil as part of a given magnetic resonance system. “Detectable” as used herein refers to distinguishable from the background noise level, that is, a magnetic resonance signal is detectable if a signal can be distinguished from background noise level with a given radiofrequency coil as part of a given magnetic resonance system. The detection volume for a given radiofrequency coil-magnetic resonance system combination can be calculated, approximated and/or measured using methods known in the art. Typically, however, it is sufficient to approximate the detection volume. For example, for a solenoid coil, typically, the detection volume is effectively, the volume enclosed within the coil, which, typically, is of about cylindrical shape. In certain embodiments a radiofrequency coil is a cylinder shape. Thus, for a solenoid a good

approximation of the detection volume is the volume of the enclosed cylinder, which can be calculated very easily. Similar approximations are known in the art for other types of radiofrequency coils (see, e.g., Mispelter, J., Lupu, M., Briquet, A. "NMR Probeheads for biophysical and biomedical experiments" 2006 Imperial College Press, London.). In certain embodiments a radiofrequency coil is wound to enclose a coil volume having a shape of about cylindrical shape and the associated detection volume is effectively the volume of the cylindrical shape. In some embodiments a radiofrequency coil is positioned to have the coil volume include between about 80 percent and about 100% of the excitable volume. In still other embodiments a radiofrequency coil is positioned to have the coil volume include effectively all of the excitable volume.

"Sensitive volume" as used herein refers to the overlap volume between the excitable volume and the detection volume, and is the volume from which magnetic resonance signals can be detected with the radiofrequency coil. A sensitive volume is determined by a fill factor (i.e., a fraction of the detection volume of an RF coil which is filled with a sample volume).

In some embodiments, a fill factor is between about 10 percent and about 100 percent. In certain embodiments a fill factor is between about 50 percent and about 100 percent. In some embodiments the fill factor is about 80 percent. In certain embodiments the fill factor is effectively 100 percent. In some embodiments a fill factor is at least about 0.1, at least about 0.5, at least about 0.75, at least about 0.9, and or about 1.

Typically, a detection volume includes between about 10 percent and about 100 percent of the excitable volume. More typically, a detection volume of a given radiofrequency coil within the probehead includes between about 50 percent and about 100 percent of the excitable volume. Even more typically, a detection volume includes about 80 percent of the excitable volume. Most typically, a detection volume includes effectively all of the excitable volume.

Also, typically, an excitable volume includes between about 10 percent and about 100 percent of the detection volume. More typically, the excitable volume includes between about 50 percent and about 100 percent of the detection volume. Even more typically, the excitable volume includes between about 80 percent and

about 100 percent of the detection volume. Most typically, the excitable volume includes effectively all of the detection volume.

Further, for a given sample volume within the probehead, typically, the sample volume includes between about 10 percent and about 100 percent of the excitable volume. More typically, the sample volume includes between about 50 percent and about 100 percent of the excitable volume. Even more typically, the sample volume includes between about 80 percent and about 100 percent of the excitable volume. Even more typically, the sample volume includes effectively all of the excitable volume. Most typically, the sample volume includes effectively all of the excitable volume and the detection volume includes effectively all of the sample volume.

In some embodiments a sample volume includes effectively all of the excitable volume and a detection volume includes effectively all of the sample volume. In still further embodiments a sample volume includes between about 10 and about 100 percent of the sensitive volume.

Typically, for a magnetic field of between about 0.2 Tesla and 1.1 Tesla, radiofrequency coils with associated detection volumes of less than about 500 μl are used. More typically, radiofrequency coils with associated detection volumes of less than about 100 μl are used. Even more typically, radiofrequency coils with associated detection volumes of less than about 10 μl are used. Even more typically, radiofrequency coils with associated detection volumes of less than about 5 μl are used. Most typically, radiofrequency coils with associated detection volumes of less than about 1.6 μl are used. In some embodiments a radiofrequency coil with associated detection volume of about 1.6 μl is used, and a sample volume of about 0.4 μl is used.

A radiofrequency coil of a given probehead of the present invention senses and/or detects magnetic resonance signals of a sample in the presence of a magnetic field and provides the sensed signals to a processing unit. The processing unit can be included within a probehead, but does not have to be included in a probehead. In any case, a probehead contains any parts, for example, circuitry, logic circuitry, power sources and other parts such as capacitors and the like, as known in the art, to allow the sensed signals to be provided to the processing unit. For example, a

probehead of the present invention that is to be used in a magnetic resonance system with a radiofrequency coil of the probehead being inductively coupled to the processing unit via an external pickup coil, typically, includes the radiofrequency coil as part of a radiofrequency circuit with one or more tuning capacitors included
5 in the circuit. In one embodiment a probehead further comprises at least one capacitor, wherein a radiofrequency coil and at least one capacitor are part of a radiofrequency circuit.

One embodiment of the present invention is a probehead for magnetic resonance relaxometry that includes (a) at least one magnet providing a magnetic
10 field, and (b) a radiofrequency coil having an associated detection volume, the radiofrequency coil being adapted and positioned such that its detection volume includes between about 80 percent and about 100 percent of an excitable volume, wherein the magnetic field has a magnetic field strengths of less than about 1.1 Tesla.

15 Another embodiment of the present invention is a probehead for magnetic resonance relaxometry that includes (a) at least one permanent magnet providing a magnetic field, and (b) a radiofrequency coil having an associated detection volume, the radiofrequency coil being adapted and positioned such that its detection volume includes between about 80 percent and about 100 percent of an excitable volume,
20 wherein the magnetic field has a magnetic field strengths of less than about 1.1 Tesla.

Another embodiment of the present invention is a probehead for magnetic resonance relaxometry that includes (a) at least one permanent magnet providing a magnetic field, and (b) a radiofrequency coil having an associated detection volume,
25 the radiofrequency coil being adapted and positioned such that its detection volume includes effectively all of an excitable volume, wherein the magnetic field has magnetic field strengths of less than about 1.1 Tesla.

Another embodiment of the present invention is a probehead for magnetic resonance relaxometry that includes (a) at least one permanent magnet providing a magnetic field, and (b) a radiofrequency coil having an associated detection volume,
30 the radiofrequency coil being adapted and positioned such that its detection volume includes effectively all of an excitable volume, wherein the magnetic field having

magnetic field strengths of less than about 1.1 Tesla, the probehead further comprising a sample volume and the sample volume including between about 10 and about 100 percent of the excitable volume.

Another embodiment of the present invention is a probehead for magnetic resonance relaxometry that includes (a) at least one permanent magnet providing a
5 magnetic field, and (b) a radiofrequency coil having an associated detection volume, the radiofrequency coil being adapted and positioned such that its detection volume includes effectively all of an excitable volume, wherein the magnetic field having magnetic field strengths of less than about 1.1 Tesla, the probehead further
10 comprising a sample volume, and the sample volume including between about 50 and about 100 percent of the excitable volume.

Another embodiment of the present invention is a probehead for magnetic resonance relaxometry that includes (a) at least one permanent magnet providing a magnetic field, and (b) a radiofrequency coil having an associated detection volume,
15 the radiofrequency coil being adapted and positioned such that its detection volume overlaps at least partly with an excitable volume, wherein the magnetic field having magnetic field strengths of less than about 1.1 Tesla, the probehead further comprising a sample volume, the sample volume including effectively all of the excitable volume and the detection volume including effectively all of the sample
20 volume.

Another embodiment of the present invention is a probehead for magnetic resonance relaxometry that includes (a) at least one permanent magnet providing a magnetic field, and (b) a radiofrequency coil having an associated detection volume,
25 the radiofrequency coil being adapted and positioned such that its detection volume overlaps at least partly with an excitable volume, wherein the magnetic field has a magnetic field strengths of less than about 1.1 Tesla, and wherein the probehead further comprises a sample volume, the excitable volume and the detection volume overlapping in a sensitive volume, and wherein the sample volume includes between about 10 and 100 percent of the sensitive volume.

30 Another embodiment of the present invention is a probehead for magnetic resonance relaxometry that includes (a) at least one permanent magnet providing a magnetic field, and (b) a radiofrequency coil having an associated detection volume,

the radiofrequency coil being adapted and positioned such that its detection volume overlaps at least partly with an excitable volume, wherein the magnetic field having magnetic field strengths of less than about 1.1 Tesla, wherein the probehead further comprises a structure defining a sample volume, the excitable volume and the
5 detection volume overlapping in a sensitive volume, and wherein the sample volume includes between about 50 and 100 percent of the sensitive volume.

Another embodiment of the present invention is a probehead for magnetic resonance relaxometry that includes (a) at least one permanent magnet providing a magnetic field, and (b) a radiofrequency coil having an associated detection volume,
10 the radiofrequency coil being adapted and positioned such that its detection volume overlaps at least partly with an excitable volume, wherein the magnetic field has a magnetic field strengths of less than about 1.1 Tesla, the probehead further comprising a sample volume, the excitable volume and the detection volume overlapping in a sensitive volume, and wherein the sample volume includes
15 effectively all of the sensitive volume.

Another embodiment of the present invention is a probehead for magnetic resonance relaxometry that includes (a) two permanent magnet providing a magnetic field, and (b) a radiofrequency coil having an associated detection volume, the radiofrequency coil being adapted and positioned such that its detection volume
20 overlaps at least partly with an excitable volume, wherein the magnetic field has magnetic field strengths of less than about 1.1 Tesla, wherein the radiofrequency coil is wound around a sample tube or capillary to enclose, the radiofrequency coil and the sample tube or capillary enclosing a sample volume within the sample tube or capillary. In certain embodiments, the excitable volume and the detection volume
25 are overlapping in a sensitive volume, and the sample volume includes between about 50 and about 100 percent of the sensitive volume.

Another embodiment of the present invention is a probehead for magnetic resonance relaxometry that includes (a) two permanent magnet providing a magnetic field, and (b) a radiofrequency circuit comprising (1) a radiofrequency coil and (2) a
30 capacitor, the radiofrequency coil having an associated detection volume and the radiofrequency coil being adapted and positioned such that its detection volume overlaps at least partly with an excitable volume, wherein the magnetic field has

magnetic field strengths of less than about 1.1 Tesla, the radiofrequency coil being wound around a sample tube or capillary to enclose, the radiofrequency coil and the sample tube or capillary enclosing a sample volume within the sample tube or capillary, the excitable volume and the detection volume overlapping in a sensitive
5 volume, and the sample volume includes between about 50 and about 100 percent of the sensitive volume.

Another embodiment of the present invention is a probehead for magnetic resonance relaxometry that includes (a) two permanent magnet attached to a yoke providing a magnetic field, and (b) a radiofrequency circuit comprising (1) a
10 radiofrequency coil and (2) a capacitor, the radiofrequency coil having an associated detection volume and the radiofrequency coil being adapted and positioned such that its detection volume overlaps at least partly with an excitable volume, wherein the magnetic field has magnetic field strengths of less than about 1.1 Tesla, the radiofrequency coil being wound around a sample tube or capillary to enclose, the
15 radiofrequency coil and the sample tube or capillary enclosing a sample volume within the sample tube or capillary, the excitable volume and the detection volume overlapping in a sensitive volume, and the sample volume including between about 50 and about 100 percent of the sensitive volume. Other specific embodiments of the present invention are the probeheads as described in the preceding paragraphs,
20 wherein a probehead is adapted for a pulse length of between about 0.4 microseconds and about 10 microseconds, between about 1 microsecond and about 4 microseconds, or between about 1.5 microseconds and 2.5 microseconds, and, independently, each magnet is independently in any dimension less than about two inches, less than about 1 inch, or less than about 0.5 inch. Other embodiments of the
25 present invention include methods of preparing probeheads provided and described in the preceding paragraphs, and the examples which follow. In one embodiment is a method for preparing a probehead for use in a magnetic resonance relaxometer. The method comprises the steps of (a) providing at least one magnet or magnetic field generator providing a magnetic field, (b) providing a radiofrequency coil, (c)
30 positioning the radiofrequency coil to have its associated detection volume overlap at least partly with an excitable volume, (d) positioning a space capable of accommodating a sample volume having an associated excitable volume; and (e)

adapting the space for the sample volume and the radiofrequency coil according to a radiofrequency pulse optimized for the magnetic field distribution corresponding to the position of the detection volume. The probehead is thus optimized to obtain relaxometry parameters from a sample contained in the sample volume.

5 Another embodiment is a method of preparing a small probehead for use in portable magnetic resonance relaxometry. The method comprises the steps of (a) attaching two magnets or two magnetic field generators to a yoke such that the south pole surface of one of the magnets or magnetic field generators opposes the north pole surface of the other magnet or magnetic field generator to form a gap between
10 the magnets or magnetic field generators and to provide a magnetic field in the gap, (b) positioning a space capable of accommodating a sample volume having an associated excitable volume, and (c) positioning a radiofrequency coil within the gap, the radiofrequency coil having an associated detection volume and being adapted to emit a radiofrequency pulse with a pulse length, the radiofrequency coil
15 being positioned and designed to have the detection volume at least partly overlap with an excitable volume within the gap. The probehead is thus optimized to obtain relaxometry parameters from a sample contained in the sample volume.

In a further embodiment a method of preparing a small probehead for use in a portable magnetic resonance relaxometer further comprises the step of providing,
20 calculating, and/or measuring a magnetic field map of the at least one magnet or magnetic field generator, and further wherein the step of providing the radiofrequency coil comprises selecting or manufacturing a radiofrequency coil dimensioned based on the magnetic field map to optimize its associated detection volume be at least as large as the excitable volume.

25 In another further embodiment a method of preparing a small probehead for use in a portable magnetic resonance relaxometer further comprises the step of providing, calculating or measuring a magnetic field map of the at least one magnet or magnetic field generator, and further wherein the step of positioning the radiofrequency coil is based on the magnetic field map to optimize its associated
30 detection volume overlap at least partly with the excitable volume.

In yet another further embodiment a method of preparing a small probehead for use in a portable magnetic resonance relaxometer further comprises the step of

providing, calculating or measuring a magnetic field map of the at least one magnet or magnetic field generator, and further wherein providing the radiofrequency coil comprises selecting or manufacturing a radiofrequency coil dimensioned based on the magnetic field map to have its associated detection volume be at least as large as the excitable volume, and positioning the radiofrequency coil is based on the magnetic field map to have the associated detection volume overlap at least partly with the excitable volume.

EXEMPLIFICATION

10 Example 1

The probehead of Figure 2 (also referred herein as "Abe" probehead) was fabricated from a custom machined c-shaped yoke **208** (0.688" x 0.5" x 0.438", steel), custom machined electronics enclosure **201** (1" x 0.5" x 0.5", aluminum), coil holders **202** (0.19" x 0.19", teflon), magnet positioner (0.438" x 0.5" x 0.063", Teflon), sample tube **203** (1mm O.D., 0.5 mm I.D., 0.6" long, Teflon), and ten-turn RF coil **204** (32 gage enamel coated copper wire, hand-wound, fastened to the sample tube by lock-tite instant adhesive). The resonant circuit was constructed by a 10-120 pF variable matching capacitor **206**, and a combination of a 10-120 pF variable capacitor **206** and two fixed capacitors **205**, and a bulkhead SMA connector **207**.

Two inexpensive, off-the-shelf permanent magnets made of NdFeB **200** were attached to the steel yoke **208** as shown schematically in Figures 1 and 5. (Figures 1 and 5 show two magnets **100** attached to a c-shaped yoke **101** and a radiofrequency coil **102** positioned between the magnets). The size of the magnets was 1/4" x 1/8" x 1/2", magnetized along the 1/8" axis. The largest dimension of the array, including the supporting yoke was 1/2". It is believed that the steel yoke helps driving the magnetic flux between the magnet blocks, following the path of high magnetic permeance.

The magnetic field was mapped by measuring along the three axis around the geometrical center of the gap between the magnet pieces. Figures 6 and 7 show the magnetic field distribution.

A solenoid radiofrequency coil **204** was designed and positioned based on the magnetic field map with the goal of maximizing the sensitive volume, (e.g., the overlap volume of excitable volume and detection volume to be excited by short duration RF pulses). This was achieved by winding the radiofrequency coil to
5 enclose a volume determined by the bandwidth of the RF pulses, provided in Figure 6 as box shaped area **600**, that is, approximately 1mm diameter by about 2 mm length. The radiofrequency coil was fabricated using these dimensions. In this manner, a coil taking up about 20% of the gap between the magnets with a microliter sensitive volume was achieved. It is contemplated that this concept can
10 be further exploited by, e.g., using more than one block at each side of the magnet. This allows for higher control on the field distribution and therefore a further size reduction keeping the same sensitive volume.

The Abe probehead was attached to a KEA spectrometer (not shown; Magritek, Wellington, New Zealand) outfitted with a Tomco pulse amplifier and
15 controlled by Prospa software (Magritek, Wellington, New Zealand). The resonant circuit was tuned at the so-called Larmor frequency by using the “wobble” macro provided by the Prospa software, that is, using standard procedures known in the art and signal was acquired utilizing a conventional CPMG pulse sequence as controlled
20 by the “cpmgadd” and “cpmgint” macros of the Prospa software, that is, by using standard procedures known in the art. Figure 8 shows the signal decay utilizing a conventional CPMG pulse sequence.

The sample was loaded by means of a syringe outfitted with a fused silica glass capillary. A series of CuSO_4 samples were analyzed as well as nanoparticle assay solutions. The nanoparticle assay solutions consisted of antibody
25 functionalized nanoparticles that bind to the beta subunit of the hCG protein (Kim, G. Y., Josephson, L., Langer, R., Cima, M. J. “Magnetic Relaxation Switch Detection of Human Chorionic Gonadotrophin”. 2007, *Bioconjugate Chemistry* 18(6), 2024-2028.). Two solutions were prepared that contained 0.14 mM nanoparticle iron and 0 and 1 $\mu\text{g/mL}$ beta subunit of hCG in PBS pH 7.4 buffer.
30 The T_2 values of these solutions were measured in a volume of 300 μL on a Bruker minispec and in a volume of 0.4 μL on the Abe probehead. Both measurements showed a decrease in T_2 upon addition of hCG. However, the absolute T_2 values on

the Abe magnet were lower than those for the Bruker minispec. It is believed that that the reason for lower values is that the T_2 value measured with the Abe probehead is an effective T_2 value that includes effects from diffusion, temperature, and stimulated echoes. However, the most important result is that addition of hCG leads to a change in the measured T_2 and this information is successfully provided using the many orders of magnitude less expensive and smaller Abe probehead.

Example 2

Magnet configuration and yoke design can be accomplished initially by a theoretical prediction of what magnet and yoke configuration will lead to in terms of magnetic field strength. This was done by using standard analytical methods. A magnet assembly including two NdFeB permanent magnets (1" x 1" x 0.5") **301** was fabricated according to this method (see "T2-yoke" in Figure 3). The yoke **300** was fabricated from steel stock using standard machining methods. The magnetic field in the x, y, and z directions was determined by fixing a gaussmeter probe relative to the magnet and moving the magnet in incremental steps with a three axis stage while recording the field strength as a function of position. The strength along the x, y, and z axes was measured by fixing two of the three directions to zero while incrementing the other. The same process was conducted for a pre-fabricated Halbach magnet (Figure 4; the figure shows the Halbach magnet **400** while the magnetic field is being measured with a Gaussmeter probe **401**).

Values obtained for a field map of each of the T2-yoke and the Halbach magnet configurations were plotted as function of position and magnetic field strength as shown in Figure 9. Data were fitted with a quadratic function ($y = ax^2 + bx + c$). The information of these plots was used to design a radiofrequency coil by determining what length in each dimension corresponds to a region that can be excited by a 2 μ s RF pulse. For example, a 2 μ s pulse excites a bandwidth of 500 kHz (bandwidth = (pulselength)⁻¹). For the T2-yoke shown in Figure 3, the homogeneous region has a field strength of 535 millitesla. The resonant frequency of hydrogen nuclei at this field can be calculated from

$$f = \gamma B_0 / 2\pi \quad (1)$$

where f is the resonant frequency in Hz, γ the gyromagnetic ratio for ^1H nuclei ($267.522 \times 10^6 \text{ rad s}^{-1} \text{ T}^{-1}$), and B_o the magnetic field in Tesla. Accordingly, the resonant frequency for the T2-yoke is 22.8 MHz. Equation 1 can also be used to determine the range of magnetic field over which a sample can be excited. Solving for B_o and substituting 500 kHz for f , a ΔB_o of 11 millitesla is calculated. This value was used to determine the length in each dimension for the volume of sample that can be excited by a 2 μs pulse. Figure 9 shows a graphical representation as to how this can be determined for each magnet. A box with a height corresponding to 11 mT is positioned on the plot such that one edge is at the minimum of the curve fit for “along the gap” and the other edge is used to determine the appropriate width of the box such that the two corners are traversed by the curve fit. The width of this box (~5 mm) corresponds to the length in this dimension that an excitation coil would enclose to maximize the sensitive volume. A similar box is shown for the Halbach magnet for the “bottom to top” dimension. Other analytical methods can be used to determine this, but the general idea is taking the ΔB_o and using the field map to translate that into a distance for each dimension.

Figures 10 and 11 show radiofrequency circuits that were fabricated for the Halbach magnet and the T2-yoke respectively to form a complete probehead. The coils **1000** were custom made from inductors that are commercially available (inductors can be hand wound as for the previous example), enclose a sample volume to which sample can be delivered through a sample tube **1001**, are part of a radiofrequency circuit that includes capacitors **1003** and a bulkhead SMA connector **1002**, and are supported by a support plate **1004**. Magnetic resonance signal was successfully measured using these probeheads (data not shown).

CLAIMS

What is claimed is:

1. A small probehead for use in a portable magnetic resonance relaxometer, comprising:
 - 5 (a) at least one magnet or magnetic field generator providing a magnetic field;
 - (b) a space capable of accommodating a sample volume having an associated excitable volume; and
 - (c) a radiofrequency coil having an associated detection volume, the
10 radiofrequency coil being adapted and positioned such that its detection volume overlaps at least partly with the excitable volume;
wherein the magnetic field provided is inhomogeneous and the space accommodating the sample volume and the radiofrequency coil are adapted and positioned according to a radiofrequency pulse bandwidth
15 optimized for a magnetic field distribution corresponding to the position of the sample volume;
and wherein the probehead is optimized to obtain relaxometry parameters from a sample contained in the detection volume.
2. The probehead of Claim 1, wherein the magnetic resonance relaxometer
20 comprises a further radiofrequency coil, a radiofrequency pulse being provided by the further radiofrequency coil.
3. The probehead of Claim 1, a radiofrequency pulse being provided by the
25 radiofrequency coil.
4. The probehead of Claim 1, further comprising a housing, wherein the at least one magnet or magnetic field generator and the radiofrequency coil is attached to the housing.
- 30 5. The probehead of Claim 1, wherein the detection volume includes between about 10 percent and about 100 percent of the excitable volume.

6. The probehead of Claim 1, wherein the detection volume includes between about 50 percent and about 100 percent of the excitable volume.
- 5 7. The probehead of Claim 1, wherein the detection volume includes between about 80 percent and about 100 percent of the excitable volume.
8. The probehead of Claim 1, wherein the detection volume includes effectively all of the excitable volume.
- 10 9. The probehead of Claim 1, wherein the excitable volume includes between about 10 percent and about 100 percent of the detection volume.
- 15 10. The probehead of Claim 1, wherein the excitable volume includes between about 50 percent and about 100 percent of the detection volume.
11. The probehead of Claim 1, wherein the excitable volume includes between about 80 percent and about 100 percent of the detection volume.
- 20 12. The probehead of Claim 1, wherein the excitable volume includes effectively all of the detection volume.
13. The probehead of Claim 1, wherein the probehead further comprises a sample volume.
- 25 14. The probehead of Claim 13, wherein the sample volume includes between about 10 percent and about 100 percent of the excitable volume.
- 30 15. The probehead of Claim 13, wherein the sample volume includes between about 50 percent and about 100 percent of the excitable volume.

16. The probehead of Claim 13, wherein the sample volume includes between about 80 percent and about 100 percent of the excitable volume.
17. The probehead of Claim 13, wherein the sample volume includes effectively
5 all of the excitable volume.
18. The probehead of Claim 13, wherein the sample volume includes effectively all of the excitable volume and wherein the detection volume includes effectively all of the sample volume.
10
19. The probehead of Claim 13, wherein the excitable volume and the detection volume overlap is a sensitive volume, and the sample volume includes between about 10 and 100 percent of the sensitive volume.
- 15 20. The probehead of Claim 1 comprising two permanent magnets providing the magnetic field.
21. The probhead of Claim 1, wherein the radiofrequency coil is part of a radiofrequency circuit, the radiofrequency circuit comprising a capacitor.
20
22. The probehead of Claim 1, wherein the radiofrequency coil is wound to enclose a coil volume having the shape of about cylindrical shape and the associated detection volume is effectively the volume of the cylindrical shape.
25
23. The probehead of Claim 22, wherein the radiofrequency coil is positioned to have the coil volume include between about 80 percent and about 100% of the excitable volume.
- 30 24. The probehead of Claim 22, wherein the radiofrequency coil is positioned to have the coil volume include effectively all of the excitable volume.

25. The probehead of Claim 22, wherein the radiofrequency coil is a cylinder shape.
26. The probehead of Claim 2, wherein the further radiofrequency coil is
5 positioned outside of the probehead.
27. The probehead of Claim 1, wherein the radiofrequency pulse length is between about 0.4 microseconds and about 10 microseconds.
- 10 28. The probehead of Claim 1, wherein the radiofrequency pulse length is between about 1 microsecond and about 4 microseconds.
29. The probehead of Claim 1, wherein the at least one magnet or magnetic field generator are shaped and/or configured to provide the magnetic field in a
15 gap, and wherein the radiofrequency coil is positioned partly or completely within the gap.
30. The probehead of Claim 29, wherein the magnetic field is provided by a
20 Halbach magnet.
31. The probehead of Claim 1, wherein the magnetic field is provided by two permanent magnets, the south pole surface of one of the permanent magnets opposing the north pole surface of the other permanent magnet to form a gap and to provide the magnetic field in the gap, the radiofrequency coil being
25 positioned partly or completely within the gap.
32. The probehead of Claim 31, wherein the magnetic field has magnetic field strengths within the gap of less than about 2 Tesla.
- 30 33. The probehead of Claim 31, wherein the magnetic field has magnetic field strengths within the gap of less than about 1.1 Tesla.

34. The probehead of Claim 31, wherein the magnetic field has magnetic field strengths within the gap of between about 0.2 Tesla and about 1.1 Tesla.
35. The probehead of Claim 31, wherein the magnetic field has magnetic field strengths within the gap of between about 0.2 Tesla and about 0.8 Tesla.
36. The probehead of Claim 31, wherein the permanent magnets are attached to a yoke.
37. The probehead of Claim 1, wherein the magnetic field has magnetic field strengths of less than about 2 Tesla.
38. The probehead of Claim 1, wherein the magnetic field has magnetic field strengths of less than about 1.1 Tesla.
39. The probehead of Claim 1, wherein the magnetic field has magnetic field strengths of less than about 0.8 Tesla.
40. The probehead of Claim 1, further comprising at least one capacitor, the at least one capacitor and the radiofrequency coil being part of a radiofrequency circuit.
41. The probehead of Claim 1, wherein each of the at least one magnet or magnetic field generator is in any dimension less than about one two inches.
42. The probehead of Claim 1, wherein each of the at least one magnet or magnetic field generator is in any dimension less than about 0.5 inches.
43. The probehead of Claim 1, wherein the radiofrequency coil is wound to enclose a volume of less than about 500 μ l.

44. The probehead of Claim 1, wherein the radiofrequency coil is wound to enclose a volume of less than about 100 μl .
45. The probehead of Claim 1, wherein the radiofrequency coil is wound to enclose a volume of less than about 10 μl .
46. The probehead of Claim 1, wherein the radiofrequency coil is wound to enclose a volume of less than about 1.6 μl .
47. The probehead of Claim 1, wherein the detection volume is less than about 500 μl .
48. The probehead of Claim 1, wherein the detection volume is less than about 100 μl .
49. The probehead of Claim 1, wherein the detection volume is less than about 10 μl .
50. The probehead of Claim 1, wherein the detection volume is less than about 1.6 μl .
51. The probehead of Claim 1, wherein the detection volume is about 1.6 μl and the sample volume is about 0.4 μl .
52. A small probehead for use in a portable magnetic resonance relaxometer, comprising:
- (a) two magnets or two magnetic field generators attached to a yoke, the south pole surface of one of the magnets or magnetic field generators opposing the north pole surface of the other magnet or magnetic field generator to form a gap between the magnets or magnetic field generators and to provide a magnetic field in the gap;

- (b) a space capable of accommodating a sample volume having an associated excitable volume; and
- (c) a radiofrequency coil within the gap, the radiofrequency coil having an associated detection volume, and being adapted to emit a radiofrequency pulse with a pulse length, and being positioned such that its detection volume overlaps at least partly with the excitable volume within the gap;
- 5
- wherein the magnetic field provided is inhomogeneous and the space accommodating the sample volume and the radiofrequency coil are adapted and positioned according to a radiofrequency pulse bandwidth optimized for the magnetic field distribution corresponding to the position of the sample volume;
- 10
- and wherein the probehead is optimized to obtain relaxometry parameters from a sample contained in the sample volume.
- 15
53. A method for preparing a small probehead for use in a portable magnetic resonance relaxometer, the method comprising the steps of:
- (a) providing at least one magnet or magnetic field generator providing a magnetic field;
- 20
- (b) providing a radiofrequency coil;
- (c) positioning the radiofrequency coil to have its associated detection volume overlap at least partly with an excitable volume associated with a sample volume;
- (d) positioning a space capable of accommodating a sample volume having an associated excitable volume;. and
- 25
- (e) adapting the space for the sample volume and the radiofrequency coil according to a radiofrequency pulse bandwidth optimized for the magnetic field distribution corresponding to the position of the sample volume;
- 30
- wherein the probehead is optimized to obtain relaxometry parameters from a sample contained in the sample volume.

54. The method of Claim 53, further comprising the step of
(f) providing, calculating or measuring a magnetic field map of the at least
one magnet or magnetic field generator;
and wherein providing the radiofrequency coil comprises selecting or
5 manufacturing a radiofrequency coil dimensioned based on the magnetic
field map to optimize the associated detection volume be at least as large as
the excitable volume.
55. The method of Claim 53, further comprising the step of
(f) providing, calculating or measuring a magnetic field map of the at least
10 one magnet or magnetic field generator;
and wherein positioning the radiofrequency coil is based on the magnetic
field map to optimize the associated detection volume overlap at least partly
with the excitable volume.
56. The method of Claim 53, further comprising the step of
15 (f) providing, calculating or measuring a magnetic field map of the at least
one magnet or magnetic field generator;
and wherein providing the radiofrequency coil comprises selecting or
manufacturing a radiofrequency coil dimensioned based on the magnetic
field map to have the associated detection volume be at least as large as the
20 excitable volume, and positioning the radiofrequency coil is based on the
magnetic field map to have the associated detection volume overlap at least
partly with the excitable volume.
57. The method of Claim 53, further comprising enclosing the at least one
25 magnet or magnetic field generator and the radiofrequency coil in a housing.
58. The method of Claim 53, wherein the detection volume includes between
about 10 percent and about 100 percent of the excitable volume.
- 30 59. The method of Claim 53, wherein the detection volume includes between
about 50 percent and about 100 percent of the excitable volume.

60. The method of Claim 53, wherein the detection volume includes between about 80 percent and about 100 percent of the excitable volume.
- 5 61. The method of Claim 53, wherein the detection volume includes effectively all of the excitable volume.
62. The method of Claim 53, wherein the excitable volume includes between about 10 percent and about 100 percent of the detection volume.
- 10 63. The method of Claim 53, wherein the excitable volume includes between about 50 percent and about 100 percent of the detection volume.
64. The method of Claim 53, wherein the excitable volume includes between
15 about 80 percent and about 100 percent of the detection volume.
65. The method of Claim 53, wherein the excitable volume includes effectively all of the detection volume.
- 20 66. The method of Claim 53, wherein the radiofrequency coil is wound to enclose a volume of cylindrical shape and the associated detection volume is effectively the volume enclosed within the cylindrical shape.
67. The method of Claim 53, wherein the radiofrequency coil is wound to
25 generate a detection volume, and the radiofrequency coil is positioned to have the detection volume include between about 80 percent and about 100% of the excitable volume.
68. The method of Claim 53, wherein the radiofrequency coil is wound to
30 generate a detection volume, and the radiofrequency coil is positioned to have the detection volume include effectively all of the excitable volume.

69. The method of Claim 53, wherein the radiofrequency coil is of about cylindrical shape.
70. The method of Claim 53, wherein the radiofrequency coil is adapted to emit
5 the radiofrequency pulse.
71. The method of Claim 53, wherein the pulse length is between about 0.4 microseconds and about 10 microseconds.
- 10 72. The method of Claim 53, wherein the pulse length is between about 1 microsecond and about 4 microseconds.
73. The method of Claim 53, wherein the at least one magnet or magnetic field generator are shaped and/or configured to provide the magnetic field in a gap
15 between a south pole surface of the gap and a north pole surface of the gap, the radiofrequency coil being positioned partly or completely within the gap.
74. The method of Claim 53, wherein the magnetic field is provided by a Halbach magnet, the Halbach magnet comprising a gap, the radiofrequency
20 coil being positioned partly or completely within the gap.
75. The method of Claim 53, wherein the magnetic field is provided by two permanent magnets, the south pole surface of one of the permanent magnets opposing the north pole surface of the other permanent magnet to form a gap
25 and to provide the magnetic field in the gap, the radiofrequency coil being positioned partly or completely within the gap.
76. The method of Claim 60, wherein the magnetic field has magnetic field strengths within the gap of less than about 2 Tesla.
30
77. The method of Claim 60, wherein the magnetic field has magnetic field strengths within the gap of less than about 1 Tesla.

78. The method of Claim 60, wherein the magnetic field has magnetic field strengths within the gap of between about 0.2 Tesla and about 0.8 Tesla.
- 5 79. The method of Claim 60, wherein the permanent magnets are attached to a yoke.
80. The method of Claim 53, wherein the magnetic field has magnetic field strengths of less than about 2 Tesla.
- 10 81. The method of Claim 53, wherein the magnetic field has magnetic field strengths of less than about 1 Tesla.
82. The method of Claim 53, wherein the magnetic field has magnetic field strengths of less than about 0.8 Tesla.
- 15 83. The method of Claim 53, further comprising at least one capacitor, the at least one capacitor and the radiofrequency coil being part of a radiofrequency circuit.
- 20 84. The method of Claim 53, wherein each of the at least one magnet or magnetic field generator is in any dimension less than about one two inches.
85. The method of Claim 53, wherein each of the at least one magnet or magnetic field generator is in any dimension less than about 0.5 inches.
- 25 86. The method of Claim 53, wherein the radiofrequency coil is wound to enclose a volume of less than about 500 μ l.
- 30 87. The method of Claim 53, wherein the radiofrequency coil is wound to enclose a volume of less than about 100 μ l.

88. The method of Claim 53, wherein the radiofrequency coil is wound to enclose a volume of less than about 10 μl .
89. The method of Claim 53, wherein the radiofrequency coil is wound to enclose a volume of less than about 1.6 μl .
90. The method of Claim 53, wherein the detection volume is less than about 500 μl .
91. The method of Claim 53, wherein the detection volume is less than about 100 μl .
92. The method of Claim 53, wherein the detection volume is less than about 10 μl .
93. The method of Claim 53, wherein the detection volume is less than about 1.6 μl .
94. A method of preparing a small probehead for use in a portable magnetic resonance relaxometer, the method comprising the steps of:
- (a) attaching two magnets or two magnetic field generators to a yoke such that the south pole surface of one of the magnets or magnetic field generators opposes the north pole surface of the other magnet or magnetic field generator to form a gap between the magnets or magnetic field generators and to provide a magnetic field in the gap;
 - (b) positioning a space capable of accommodating a sample volume having an associated excitable volume; and
 - (c) positioning a radiofrequency coil within the gap, the radiofrequency coil having an associated detection volume and being adapted to emit a radiofrequency pulse with a pulse length, the radiofrequency coil being positioned and designed to have the detection volume at least partly overlap with an excitable volume within the gap;

wherein the probehead is optimized to obtain relaxometry parameters from a sample contained in the sample volume.

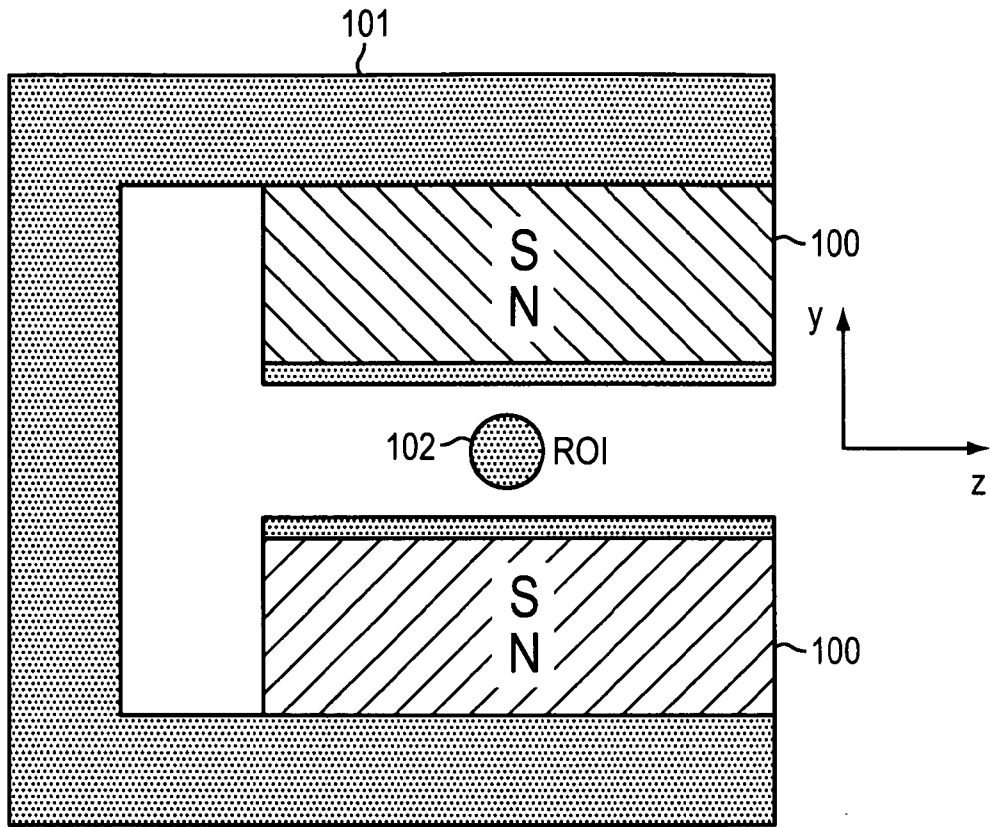

FIG. 1

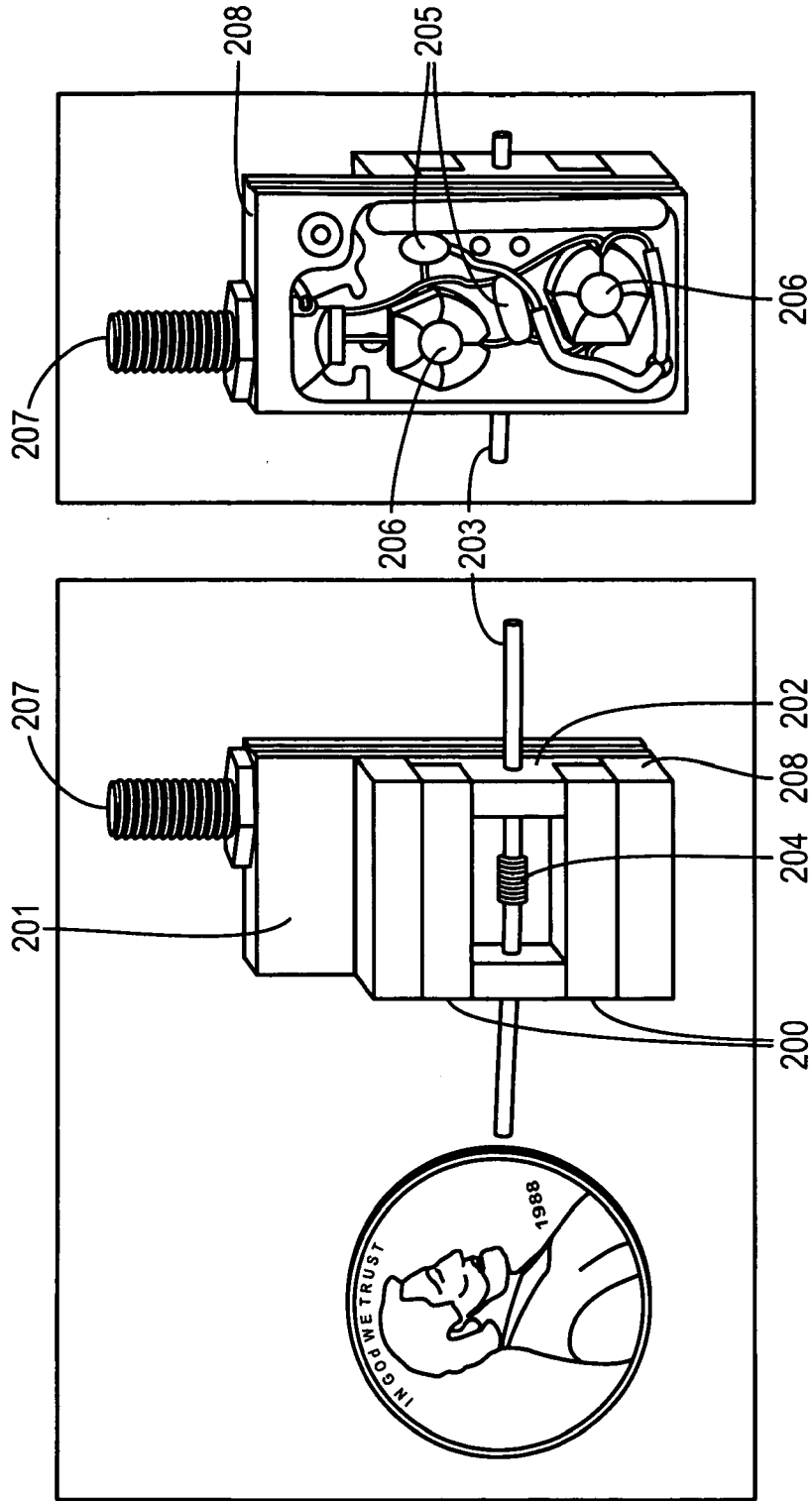

FIG. 2

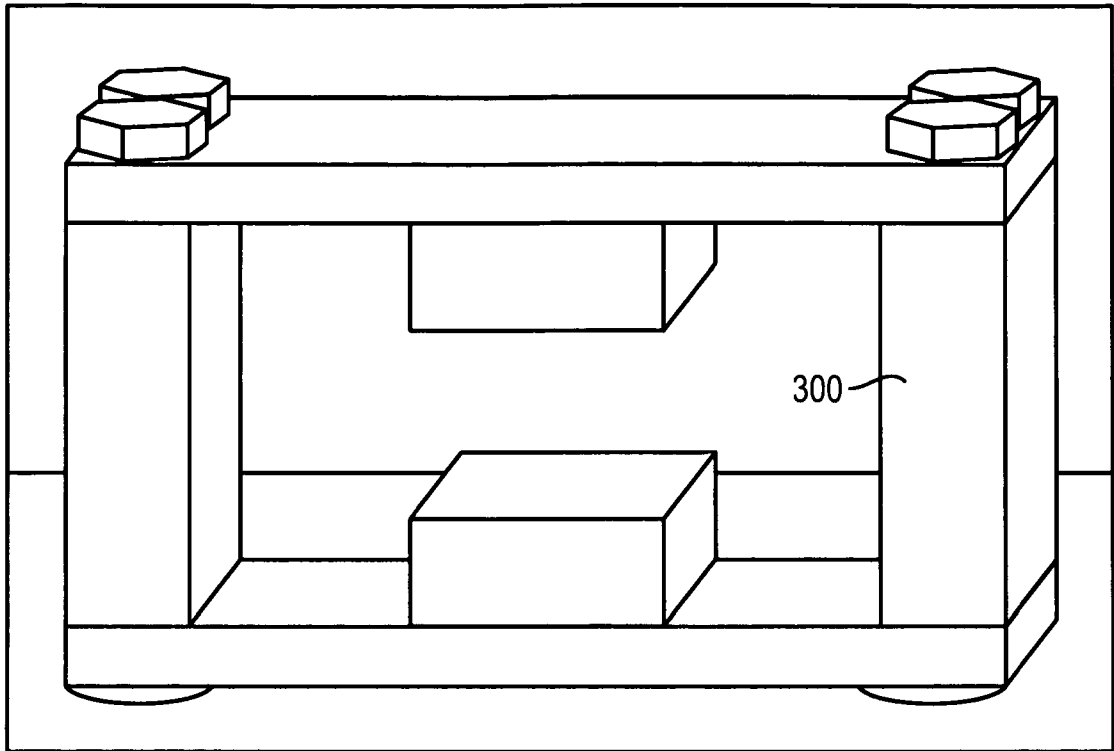

FIG. 3

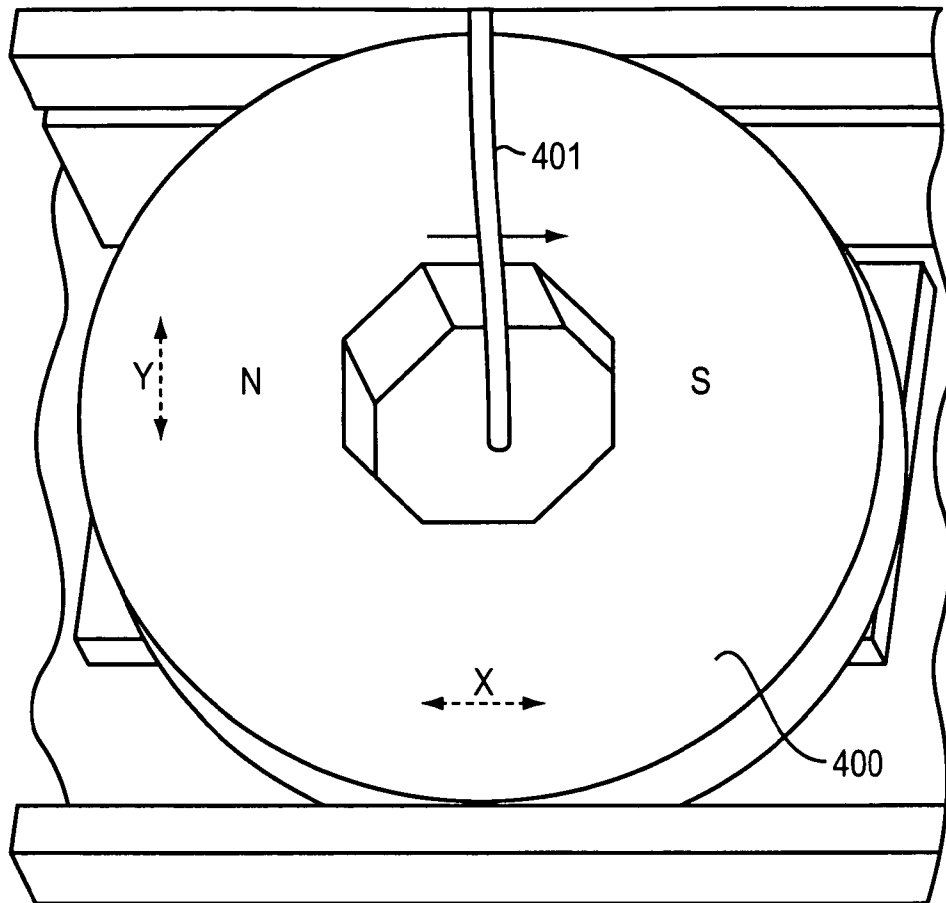

FIG. 4

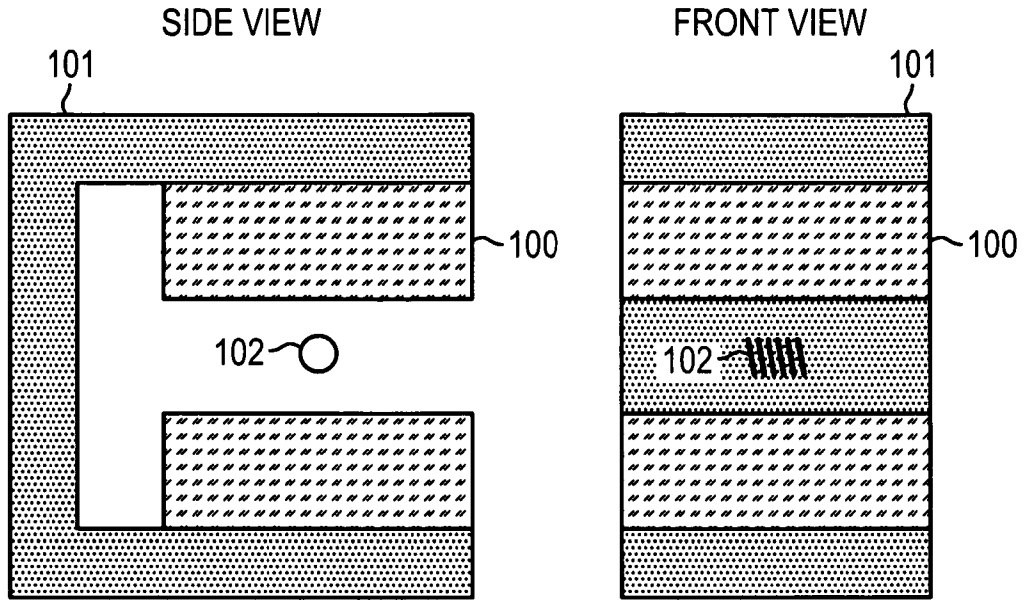

FIG. 5

6/11

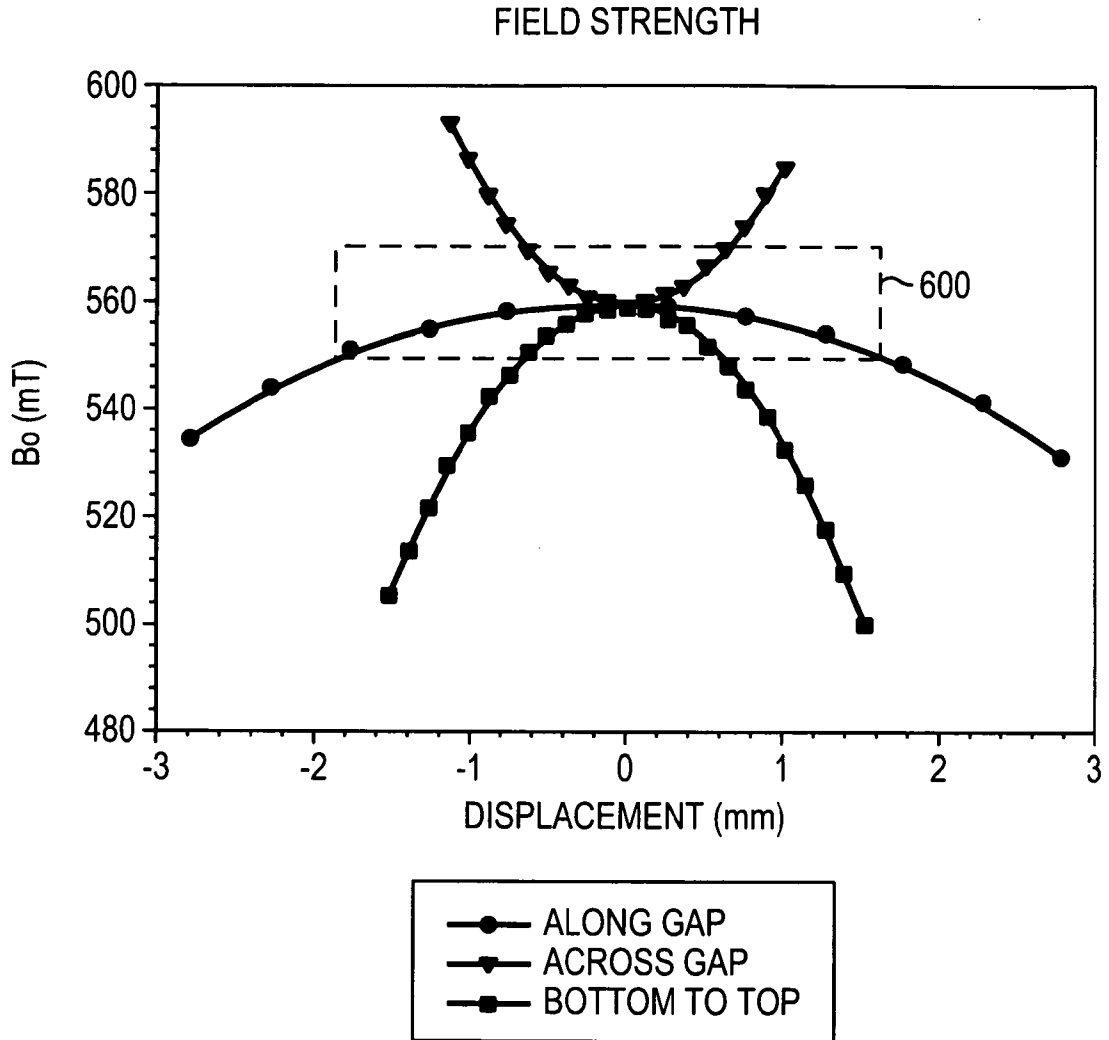

FIG. 6

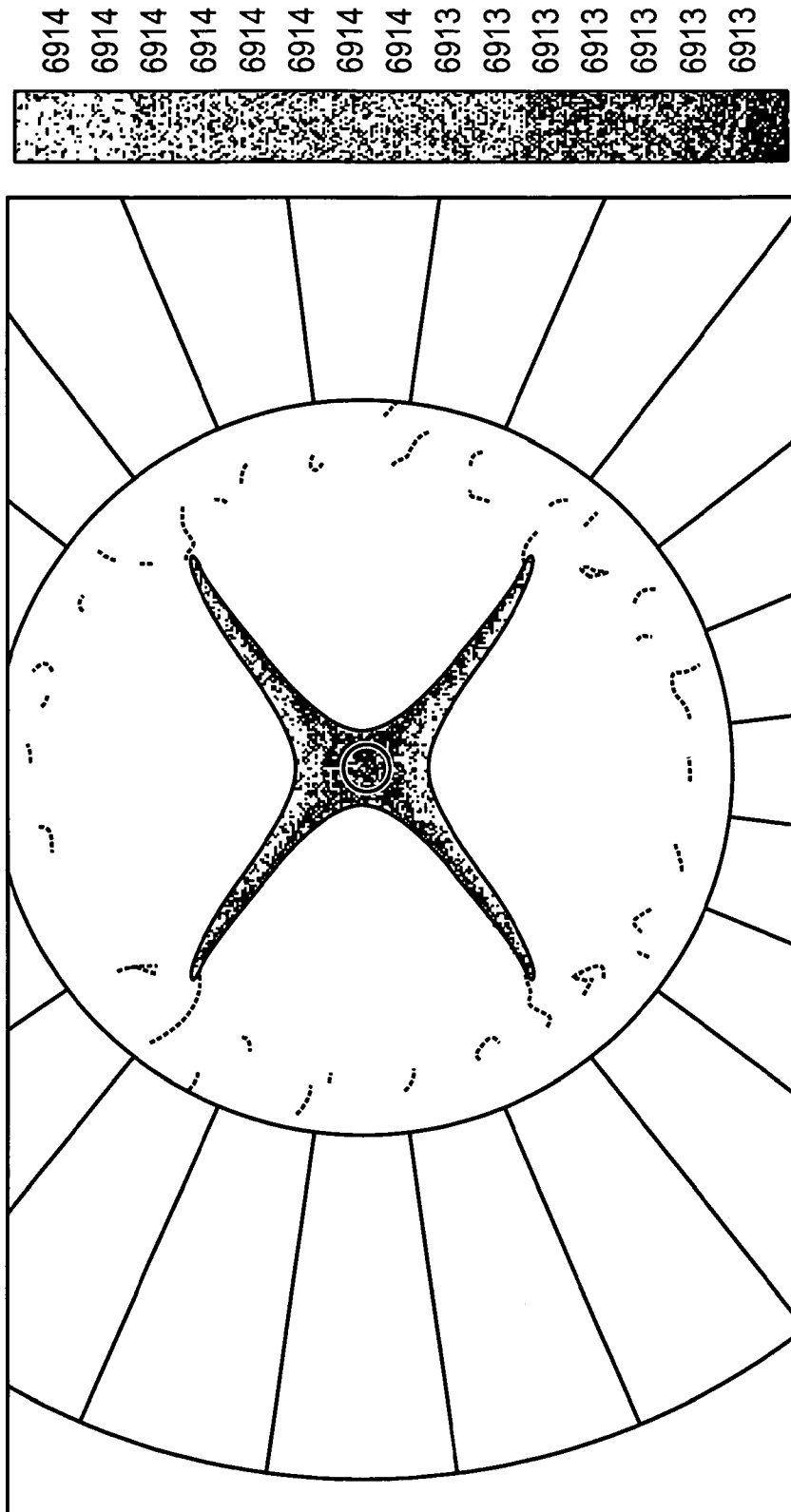

FIG. 7

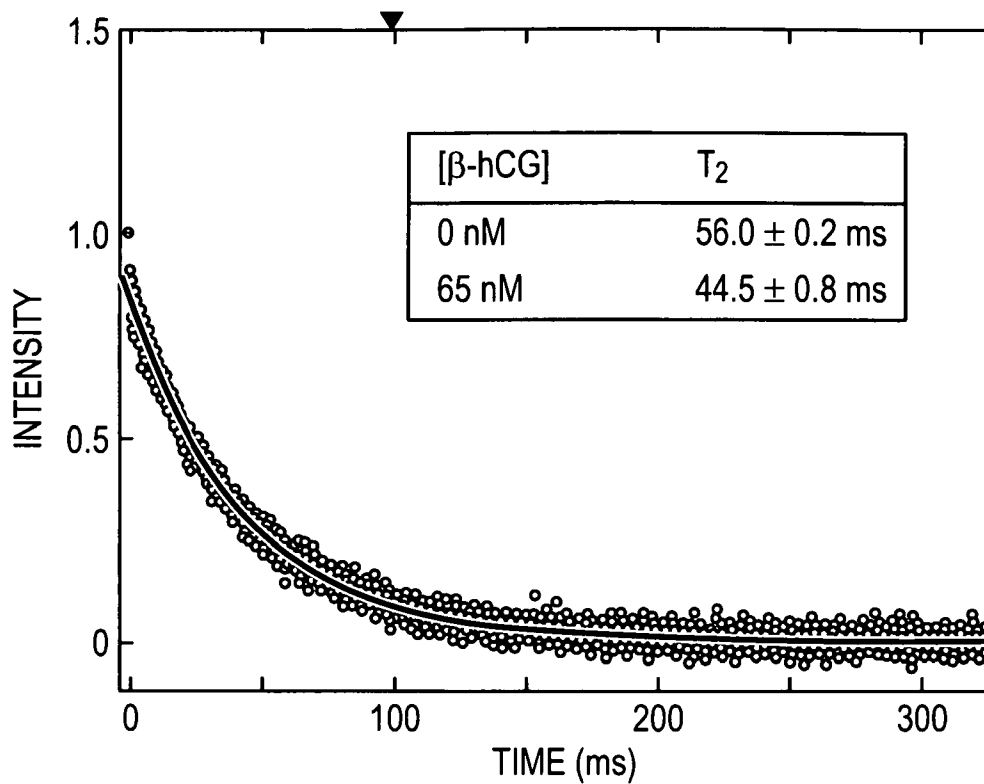

FIG. 8

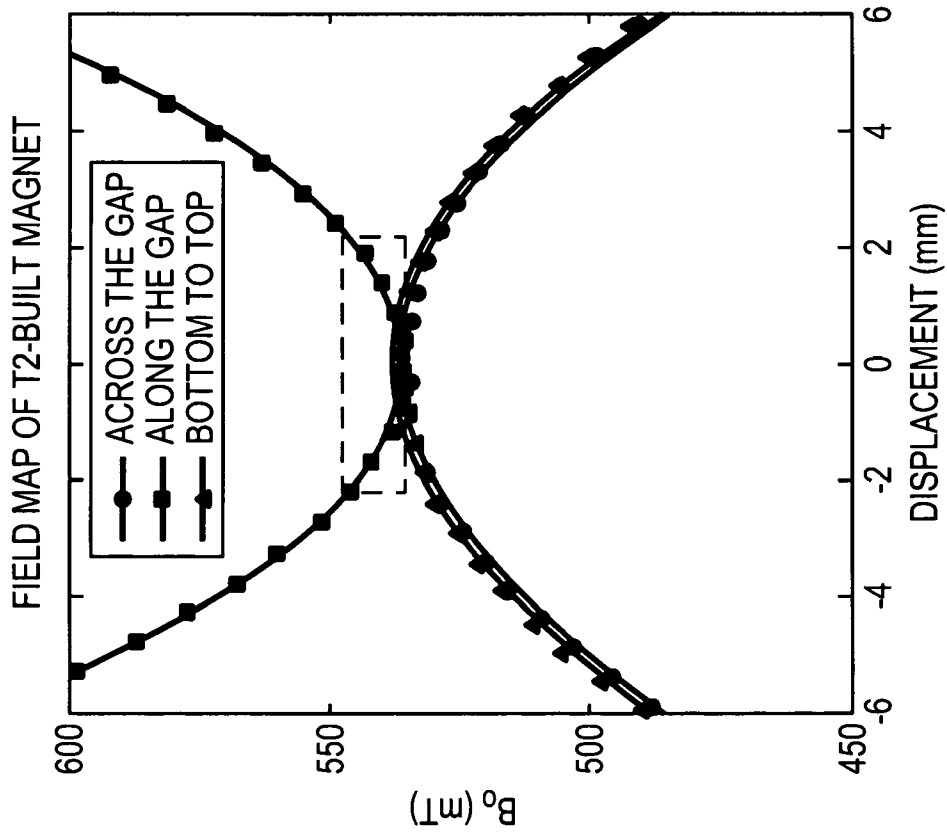
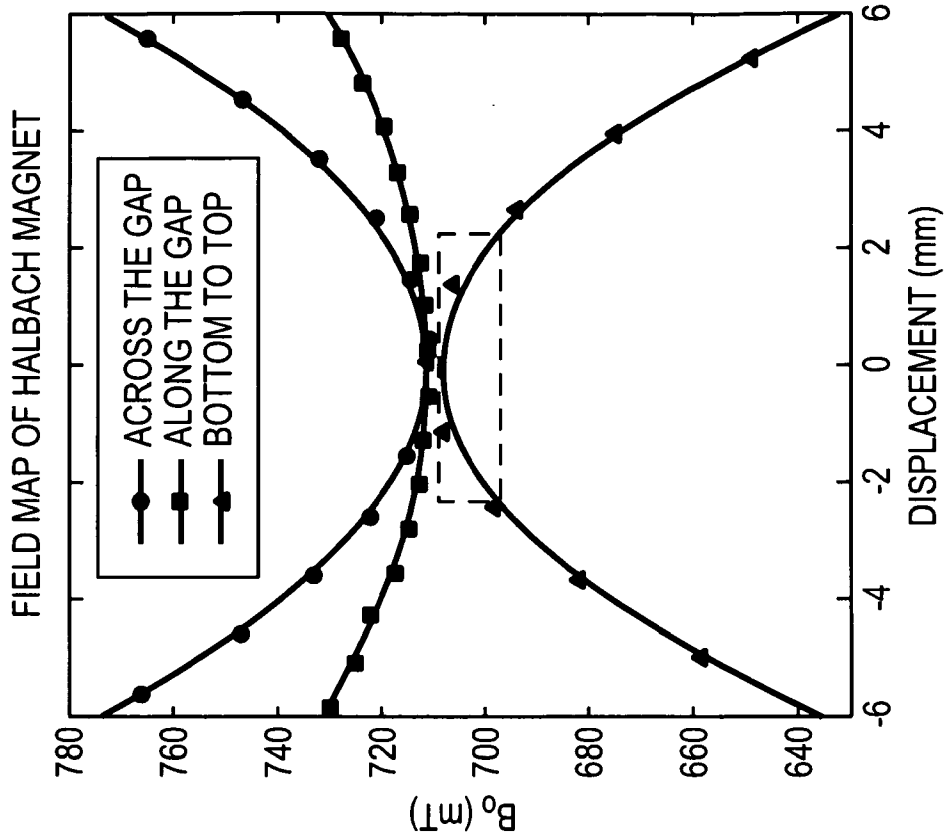

FIG. 9

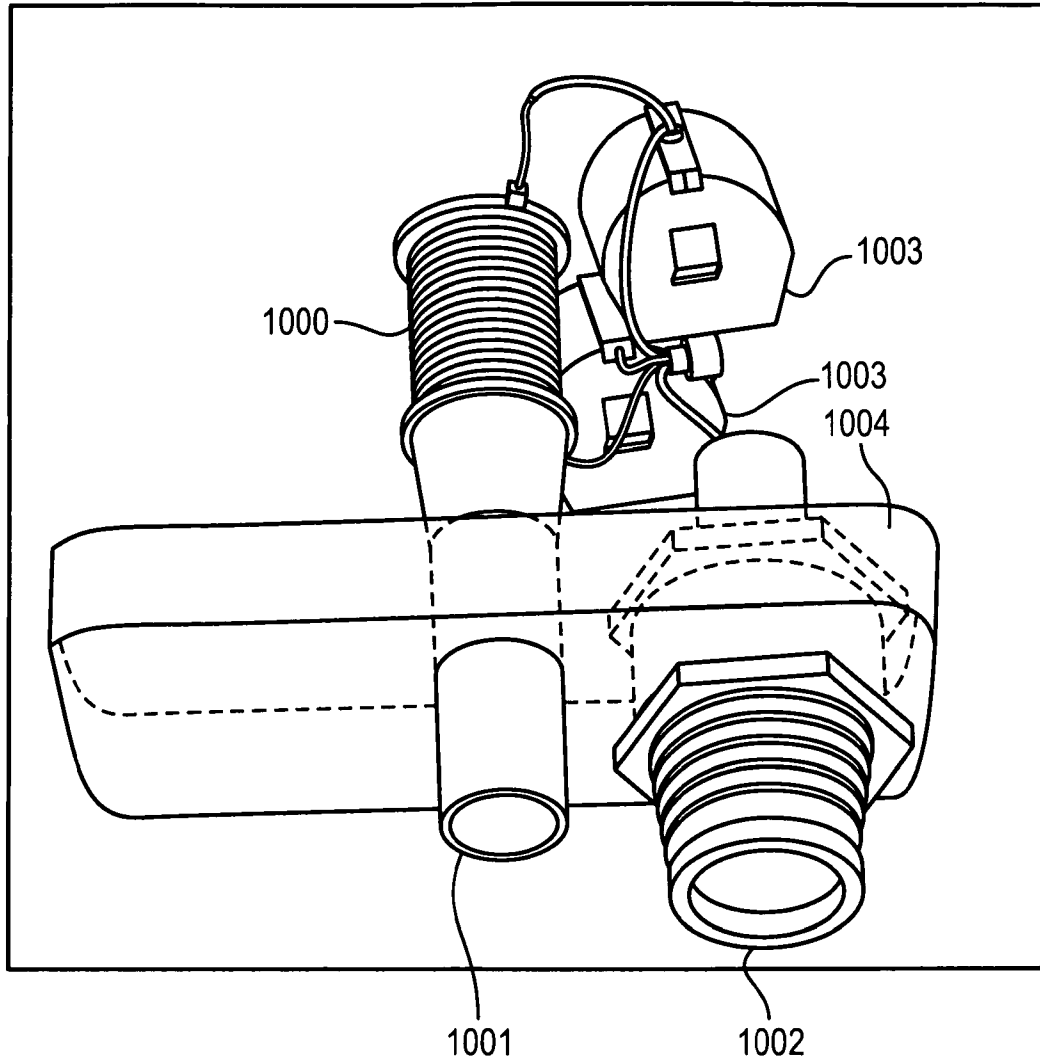

FIG. 10

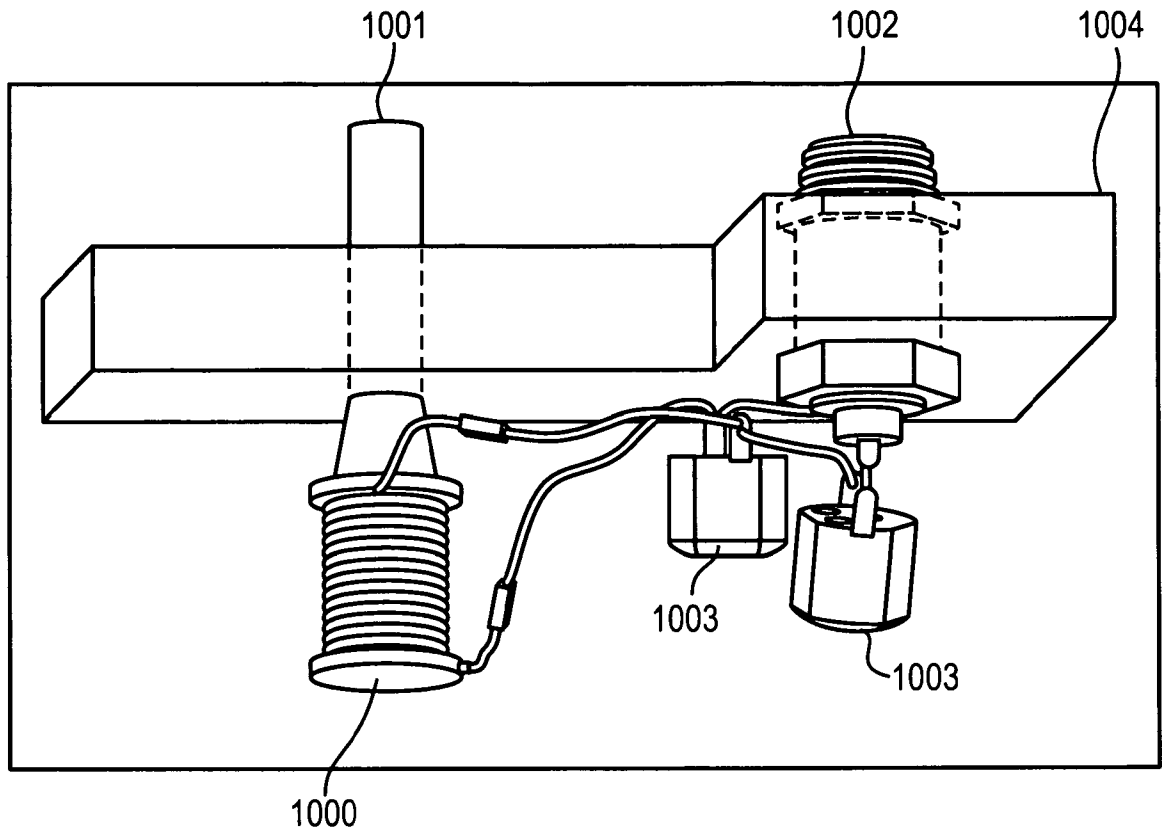

FIG. 11

INTERNATIONAL SEARCH REPORT

International application No.
PCT/US2008/012592

A. CLASSIFICATION OF SUBJECT MATTER
 IPC(8) - G01V 3/00 (2009.04)
 USPC - 324/309
 According to International Patent Classification (IPC) or to both national classification and IPC

B. FIELDS SEARCHED
 Minimum documentation searched (classification system followed by classification symbols)
 IPC(8) - G01V 3/00 (2009.04)
 USPC - 324/309

Documentation searched other than minimum documentation to the extent that such documents are included in the fields searched

Electronic data base consulted during the international search (name of data base and, where practicable, search terms used)
 MicroPatent, IP.com, DialogPro

C. DOCUMENTS CONSIDERED TO BE RELEVANT

Category*	Citation of document, with indication, where appropriate, of the relevant passages	Relevant to claim No.
Y	US 6,958,609 B2 (RAFTERY et al) 25 October 2005 (25.10.2005) entire document	1-94
Y	US 5,910,728 A (SODICKSON) 08 June 1999 (08.06.1999) entire document	1-51 and 53-93
Y	US 4,574,240 A (LIBOVE et al) 04 March 1986 (04.03.1986) entire document	5-7, 9-11, 14-16, 19, 58-60, 62-64, and 76-79
Y	US 7,034,536 B2 (HIGUCHI) 25 April 2006 (25.04.2006) entire document	20, 31-36, 52, 75, and 94
Y	US 6,940,378 B2 (MILLER et al) 06 September 2005 (06.09.2005) entire document	30 and 74
Y	US 6,194,898 B1 (MAGNUSON et al) 27 February 2001 (27.02.2001) entire document	45-46, 49-51, 88-89, and 92-93

Further documents are listed in the continuation of Box C.

* Special categories of cited documents:
 "A" document defining the general state of the art which is not considered to be of particular relevance
 "E" earlier application or patent but published on or after the international filing date
 "L" document which may throw doubts on priority claim(s) or which is cited to establish the publication date of another citation or other special reason (as specified)
 "O" document referring to an oral disclosure, use, exhibition or other means
 "P" document published prior to the international filing date but later than the priority date claimed
 "T" later document published after the international filing date or priority date and not in conflict with the application but cited to understand the principle or theory underlying the invention
 "X" document of particular relevance; the claimed invention cannot be considered novel or cannot be considered to involve an inventive step when the document is taken alone
 "Y" document of particular relevance; the claimed invention cannot be considered to involve an inventive step when the document is combined with one or more other such documents, such combination being obvious to a person skilled in the art
 "&" document member of the same patent family

Date of the actual completion of the international search
05 January 2009

Date of mailing of the international search report
15 JAN 2009

Name and mailing address of the ISA/US
 Mail Stop PCT, Attn: ISA/US, Commissioner for Patents
 P.O. Box 1450, Alexandria, Virginia 22313-1450
 Facsimile No. 571-273-3201

Authorized officer:
 Blaine R. Copenheaver
 PCT Helpdesk: 571-272-4300
 PCT OSP: 571-272-7774