

(No Model.)

2 Sheets—Sheet 1.

C. H. HEYWOOD.

ELEVATOR FOR FEEDING SHEETS OF PAPER.

No. 580,942.

Patented Apr. 20, 1897.

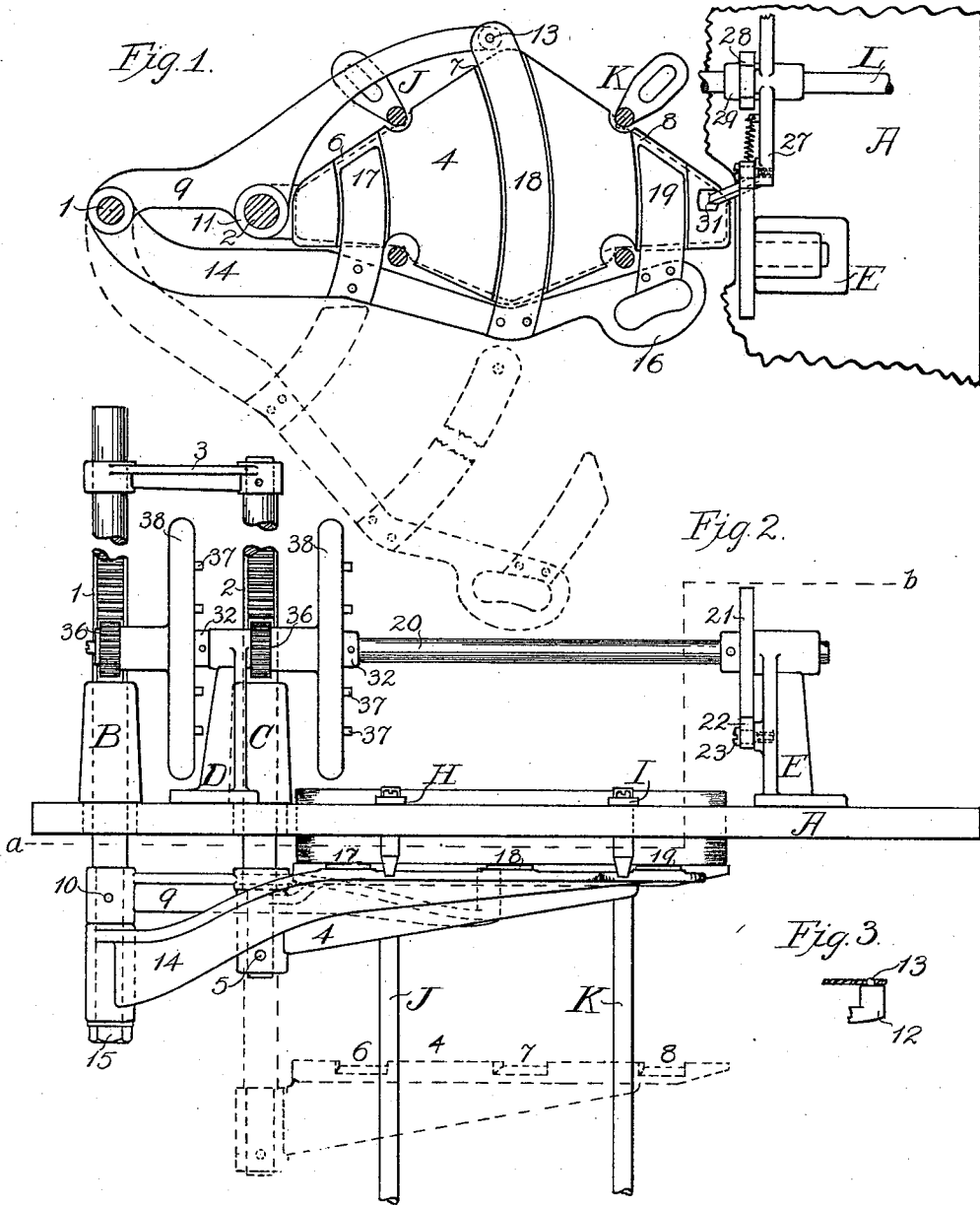

Witnesses  
*L. H. Horner.*  
*C. C. Stinson.*

Inventor  
*Charles H. Heywood*  
 By *Allen Melster*  
 Attorney

C. H. HEYWOOD.  
ELEVATOR FOR FEEDING SHEETS OF PAPER.

No. 580,942.

Patented Apr. 20, 1897.

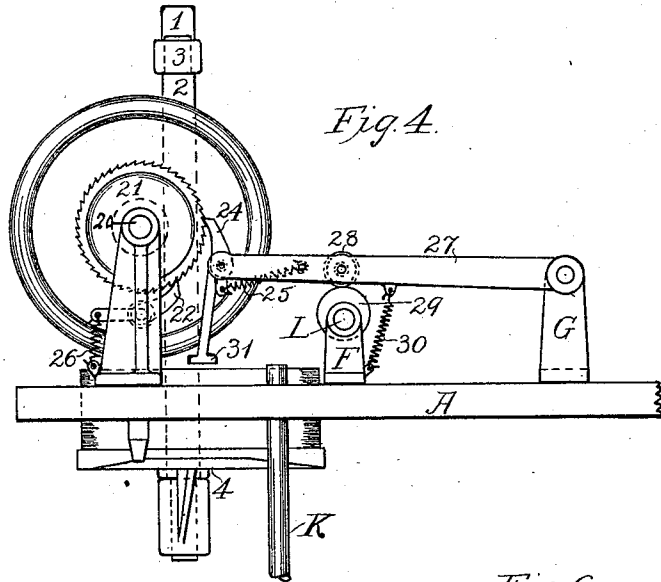

Fig. 4.

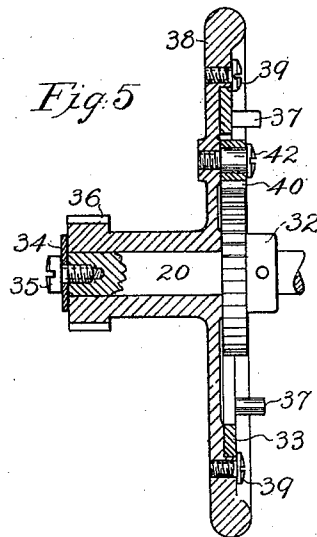

Fig. 5.

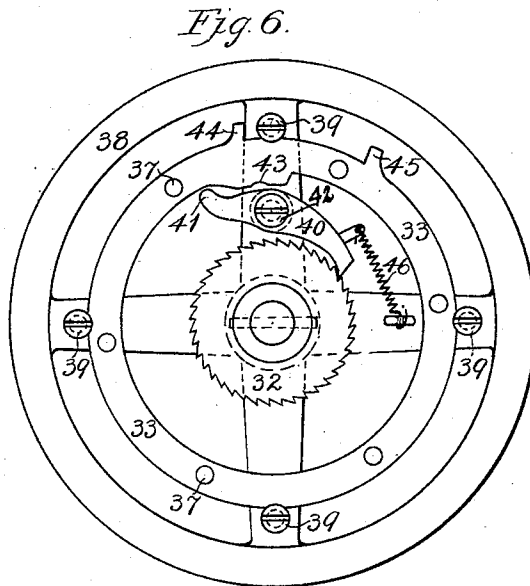

Fig. 6.

Witnesses:  
*L. H. Homer.*  
*O. C. Stickney.*

Inventor  
*Charles H. Heywood*  
 By *Allan Webster*  
 Attorney

# UNITED STATES PATENT OFFICE.

CHARLES HENRY HEYWOOD, OF MILWAUKEE, WISCONSIN.

## ELEVATOR FOR FEEDING SHEETS OF PAPER.

SPECIFICATION forming part of Letters Patent No. 580,942, dated April 20, 1897.

Application filed August 13, 1895. Serial No. 559,188. (No model.)

*To all whom it may concern:*

Be it known that I, CHARLES HENRY HEYWOOD, a citizen of the United States of America, residing in Milwaukee, in the county of Milwaukee and State of Wisconsin, have invented new and useful Improvements in Elevators for Feeding Sheets of Paper or other Material, of which the following is a specification, reference being had to the accompanying drawings and letters and figures of reference marked thereon.

This invention relates to a class of elevators in which the paper is fed to the machine continuously. As the paper is fed to the machine from off the top of the stack the stack is added to by more paper placed beneath and raised up into contact with the stack above. In this way paper is fed from the top of stack without being interrupted when a new supply is being added to the stack.

Mechanisms have heretofore been devised for supplying paper to the under side of the stack, in which two platens or duplicate plates are usually combined, each designed to be operated independently of the other, but none to my knowledge have been devised in which are combined a main platen with an arrangement of blades to be used only to support the remaining sheets of the stack during the time the fresh supply is being placed upon the platen. In other words, my device has practically one platen upon which the paper is at all times placed and materially differs from other feeding mechanisms.

In the accompanying drawings, in which like letters and figures of reference indicate like parts, Figure 1 is a section on line *a b*, Fig. 2, showing part of the table of the machine and the platen and retaining-blades in position. Fig. 2 is a front elevation of the elevator in operation, showing some paper in position to be fed to the machine, while the platen of the elevator is shown in dotted lines lowered in position to receive a new supply of paper. Fig. 3 is a detached view showing the manner in which the blades are retained in position when supporting the stack. Fig. 4 is a side elevation taken from the right of Fig. 1, illustrating the manner in which the upward motion may be given to the elevator-platen by a cam and lever. Fig. 5 is a section view of one of the elevator hand-wheels and

shows it in position on its shaft with the pawl resting upon the ratchet; and Fig. 6 is a side elevation of Fig. 5, with the hand-wheels complete and all the parts thereon.

In detail, A indicates the table; B and C, sleeves; D and E, stands; F and G, brackets; H, I, J, and K, gages, and L driving-shaft.

The construction is as follows: To the table A are attached the sleeves B and C to provide guides for the rods 1 and 2.

D and E are stands fastened upon the table A and supporting the shaft 20.

F is a bracket in which a driving-shaft rotates.

G indicates a bracket-supporting lever 27.

H I J K are corner-gages, the two former fastened upon the table at the front, while the two latter are supported at their lower ends upon any convenient portion of the machine.

In Fig. 1, 4 is the main platen from which the upper paper is fed to the machine. This platen is fastened upon rack-rod 2 by a pin 5. (Shown in Fig. 2.) The construction of this platen is as follows: Extending from the hub fastened to the rounded lower end of the rack-bar 2 by a pin 5 is an arm reaching up and supporting the platen 4. The face of this platen is formed with three concentric grooves or channels 6 7 8, of such depth as to allow the passage of the coinciding curved blades 17 18 19, which project horizontally from and have one end secured to the arm 14. When these blades are in position, as shown in Fig. 1, the surfaces of the platen and blades are flush, forming a continuous surface for the support of the paper. The rack-rod 2, on which the platen is fastened, extends upward through the sleeve C, past the gear 36, and carries a laterally-projecting arm 3, pinned upon the top. Parallel with the rack-rod 2 is a similar rack 1. This rack-rod 1 extends down through sleeve B and has arm 9 fastened thereto by pin 10, and then through the arm 14, and has a nut 15 on the end, which holds the arm 14 in position. The top of the rod 1 passes through the free end of the arm 3. This gives support to the rod 2 in such way that said rod-carrying platen 4 may be raised or lowered and maintain its position beneath the paper without other than vertical motion.

The arm 14, carrying the blades 17 18 19, is arranged to swing outward upon the rod 1,

and when swung out the blades 17 18 19 travel through the channels before referred to in platen 4. These channels are shown in dotted lines in Fig. 2. The arm 9, fastened on the rod 1, extends across with the hub 11, circling the rod 2, and its end supports the end of blade 18 and contains a pin 13, (see Fig. 3,) that retains the blade and arm 14 in position. The arm 9 is so made that when the sleeve 11 rests on the hub of the platen 4 the blades 17 18 19 are flush with the platen 4. By this arrangement the blades of frame 14 can never get below the surface of the platen, but the platen may be lowered below the blades to any depth required, according to the length of the rack-rod 2. This will readily be understood upon reference to Fig. 2.

By rotating the wheels 38 38, that carry the gears 36 36, the rack-rods are raised and lowered, thus elevating or depressing the platen or the supporting-blades. As arm 9 is firmly fastened to the rod 1, it is always held in position and restrained from other than a vertical movement by the sleeve 11 upon the rod 2.

Supported by standards D and E is the shaft 20, carrying ratchets 32 32 21. These three ratchets are pinned to the shaft and rotate therewith. Ratchet 21 is prevented from rotating backward by a pawl 22 on the screw 23 and is held in position by a spring 26. This pawl prevents the backward movement of the shaft 20. The means for raising the paper upward as it is fed off the stack in the machine may be of any convenient form of construction. I have illustrated one way it may be done, consisting of the lever 27, fulcrumed on stand G and carrying the cam-roller 28, rolling in contact with the cam 29 upon the shaft L. This lever carries a pawl 24, which is termed a "feeding-pawl," while the lever itself terminates in the bent portion 31 and extends downward and over the paper. By the action of this lever through the cam 29, after the paper is raised to the proper height, if the top sheets of the stack be removed, the portion 31 of the lever will be allowed to move to a lower position than it would if the paper were there to prevent further downward movement of the lever. If the paper be removed and the lever move lower, the pawl 24 will descend and take a tooth in the ratchet 21, and when forced upward by the cam 29 will elevate the platen and paper. A constant feed with a train of spur-gears might be provided for feeding the platen upwardly.

The manner of raising the stack to keep the top always in the same plane as sheets are fed off has nothing to do with my invention. I make no claim on this part. The stack may be kept at proper height by the operator or by any suitable mechanism in common use, one of which is illustrated herein.

In Fig. 6 the hand-wheel 38 is shown carrying the connecting mechanism. The hand-wheels 38 38 turn freely upon the shaft 20 in one di-

rection at all times. The hubs of the wheels are provided with the gears 36, which engage racks 1 and 2, the wheels being arranged on a shaft 20, so that the racks are elevated by rotating the wheel in the proper direction. As this is done the pawl 40 on the screw 42 will travel around the ratchet 32, the point actuated by spring 46 always dropping in a tooth of the ratchet to maintain the platen in any desired position. Inside the wheels 38 38 are fastened rings 33 33. These rings are let into the wheel and retained in position by screws 39. On the inner surface of these rings is a cam portion in which is cut a notch 43, the object of which notch is to retain the pawl 40 out of contact with the ratchet 32. When the ring 33 shall have been rotated sufficiently for the notch to engage the tail 41 of pawl 40, a stop 45 upon the ring 33 will abut against the arm of the wheel 38 and arrest the motion of the ring. On the opposite side of the wheel-arm is another stop 44, which acts as the ring is moved in the opposite direction, as shown in the drawings. Projecting from the side of the ring 33 are pins 37. These pins are designed to be used as handles for the turning of the ring 33. The two hand-wheels are exactly alike in all particulars, rotating freely by hand upon the shaft 20 in a direction to raise the platen and prevented from rotating backward by the pawls 40, as described. As the ratchet 21 never moves backward, but is fed forward as fast as it is necessary, the wheels 38 are carried by the ratchets 32 32 just as fast as the ratchet 21 is advanced. When it is necessary to lower the platen, the ring 33 is shifted to throw the pawl 40 out of engagement with the ratchet and the platen will descend. As the sleeve 11 of arm 9 rests upon the hub of the platen 4, and as that platen is raised and lowered, all mechanism for carrying the arm 14 with the blades 17 18 19 will be raised and lowered with the platen, providing the pawl 40 is not in contact with the ratchet 32 for supporting the rod 1. The right-hand wheel 38 rotates freely on the shaft 20 between ratchet 32 and stand D. The left-hand wheel 38 is supported on one side by ratchet 32 and a screw 35 and washer 34 on the end of the shaft.

The elevator is supplied with paper as follows: The parts being in their respective positions, as shown in Fig. 2, and it being now desirable to add more paper to the stack shown in this figure the pawl 40 for rod 1 is dropped into engagement with the ratchet, thereby holding arm 14 and blades from downward movement, and the pawl 40, holding the rack-rod 2 on the platen 4, is thrown out, thus allowing the platen 4 to descend to position corresponding to that shown in Fig. 2 in dotted lines, the arm 14 with the blades 17 18 19 now supporting the stack of paper, and as there are but a few sheets thereon the strength of the blades is sufficient. The supply of paper is now placed upon the platen 4 while in

its lowered position. The pawl 40 is then thrown into contact with the ratchet and the hand-wheel 38 revolved until the top of the stack is brought into contact with the under side of blades 17, 18, and 19. Arm 14 is then swung outward, drawing the blades out from beneath the stack resting upon them, thus allowing the upper stack to drop to the lower stack, and the rod 1 is then lowered until the sleeve 11 on the arm 9 rests upon the hub of the platen 4. The blades are then swung into the channels 6 7 8 until blade 18 snaps over the pin 13, where it is retained in position.

Having, therefore, described my invention, what I claim, and desire to secure by Letters Patent, is—

1. In an elevator for feeding sheets of paper, a platen formed with channels means for raising and lowering the platen through guides by rack-gear and wheels or their equivalents, combined with one or more blades fitting the channels in the platen and fastened to an arm or slide and arranged to swing in and out the platen-channels, and means for raising and lowering them through guides by rack-gear and wheels or their equivalent, all arranged substantially as shown and for the purpose specified.

2. In an elevator for feeding sheets of paper, a platen combined with one or more blades fastened on an arm substantially as shown and arranged to support a stack of paper while the platen is lowered to receive a new supply, substantially as shown.

3. In an elevator for feeding sheets of paper, a platen operated by a rack in combination with an arm, carrying one or more blades operated by duplicate racks, substantially as shown and described.

4. In an elevator for feeding sheets of paper, the combination of a channeled platen combined with blades fitting the channels and fastened on an arm, arm and platen being fastened to vertical racks, hand-wheel and gears, rotating on a shaft to raise and lower the platen and blades, all in combination with a ratchet and pawl on the shaft whereby the platen or blades may be retained at any height, substantially as shown.

5. In an elevator for feeding sheets of paper, a vertically-movable platen to which the paper is supplied, an upright shaft movable vertically and rotatable on its axis, a lateral supported arm on said shaft and one or more blades horizontally projected from the arm, in combination with vertically-movable rack-bars, gears to engage the rack-bars whereby the platen and blades may be lowered and raised independently of each other, pawls 32,

and ratchets 40, 40, to hold the platen and blades in any desired position.

6. In an elevator for feeding sheets of paper, a compound platen comprising a platen having concentric channels across its face and an arm provided with blades to engage in the channels, a shaft having ratchets fastened thereon, held from rotating in one direction by a pawl, one or more hand-wheels provided with gears and rotating freely on said shaft and provided with pawls fastened thereon and rotating on the ratchets so that the wheels may turn in one direction only

7. In an elevator for feeding sheets of paper, a feed-wheel rotating freely beside a ratchet carried on a shaft, a pawl fastened on said wheel and a shifting device contained on said wheel and arranged to lift and hold the pawl out of contact with the ratchet so that the wheel may be turned in either direction to raise or lower racks attached to a compound platen, substantially as shown.

8. In an elevator for feeding sheets of paper, the combination of a shaft provided with one or more ratchets and a retaining-pawl and ratchet whereby the shaft may be rotated in one direction only by being combined with suitable means for advancing the retaining-ratchet tooth by tooth, with one or more hand-wheels carrying pawls and throwing-out means, substantially as shown, located thereon beside the ratchets and having gears meshing into racks for the purpose of raising a platen and supporting-blades, whereby the platen and supporting-blades are moved upward every time the retaining-pawl is advanced a tooth, substantially as shown.

9. In an elevator for feeding sheets of paper, a platen formed with concentrically-curved channels across its face, a horizontally-swinging arm provided with curved blades to fit in the channels of the platen and means to raise and lower the platen and arm with blades independently of each other.

10. In an elevator for feeding sheets of paper, a vertically-reciprocating platen formed with concentric channels across its face, means to raise and to lower the platen, an arm adapted to be swung in a horizontal plane parallel with the plane of the platen and provided with curved blades to fit the channels of the platen, means to raise and lower the arm with blades independently of the platen, and means to raise and lower the platen and blades in unison.

CHARLES HENRY HEYWOOD.

Witnesses:

EDWARD BARBER,  
EDWARD B. BARBER.