

J. M. Blackstock,

Scroll Saw.

No. 91,900.

Patented June 29, 1869.

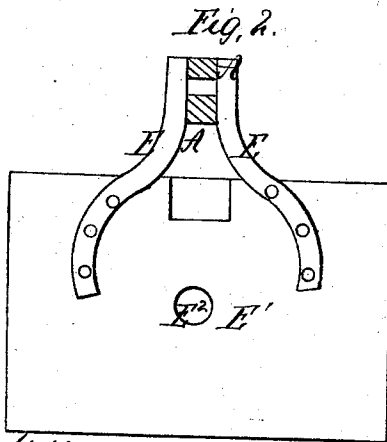
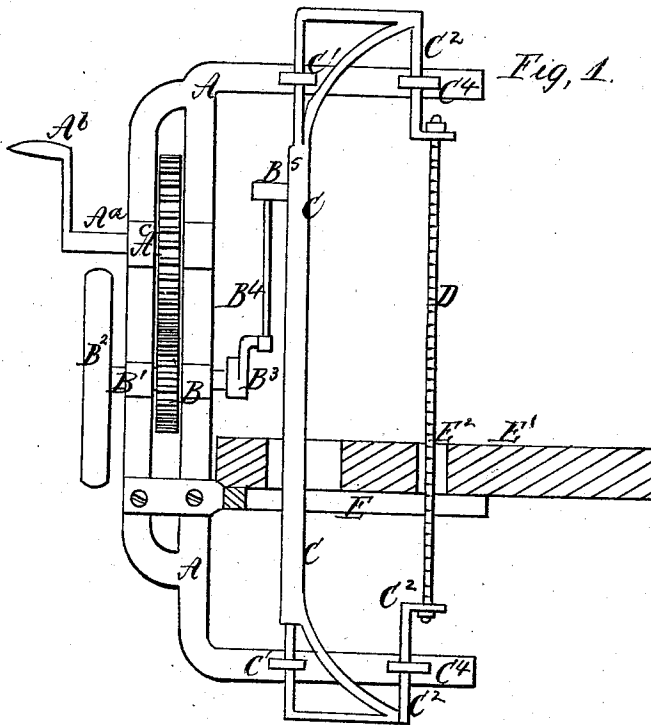

Witnesses
Perceval B. Bickett
John P. Clark

Inventor,
James M. Blackstock

United States Patent Office.

JAMES M. BLACKSTOCK, OF TARENTUM, PENNSYLVANIA.

Letters Patent No. 91,900, dated June 29, 1869.

IMPROVEMENT IN SCROLL-SAWING MACHINE.

The Schedule referred to in these Letters Patent and making part of the same.

To all whom it may concern:

Be it known that I, JAMES M. BLACKSTOCK, of Tarentum, in the county of Allegheny, and State of Pennsylvania, have invented certain new and useful Improvements in Scroll-Saws; and I do hereby declare that the following is a full, clear, and exact description thereof, reference being had to the accompanying drawings, and to the letters of reference marked thereon, which form a part of this specification.

The nature of my invention consists in the use of devices whereby ordinary scroll-sawing machines can be run by hand-power, and attached to and detached from any ordinary workshop-bench.

To enable others skilled in the art to make and use my invention, I will describe its construction and operation.

In the accompanying drawings—

Figure 1 is an elevation of my improvements in scroll-saws as attached to an ordinary shop-bench.

Figure 2, a sectional plan of some of the details:

Letters of reference denote parts.

A frame-work, A, consisting of two vertical parallel bars and horizontal side pieces, sustains most of the devices used, revolving in suitable bearings, attached to which is a driving-shaft, A^a, provided at the one extremity with an ordinary cranked handle, A^b, and an ordinary spur-pinion, A^c, situated between the before-named vertical bars.

This spur-pinion A^c rotates a spur-wheel, B, affixed to a counter-shaft, B¹, also revolving in suitable bearings on the frame A, said shaft B¹ being provided at the outer extremity with an ordinary fly-wheel, B², and on the inner end with an ordinary crank, B³, of suitable proportions and construction, attached to which is an ordinary connecting-rod, B⁴, its upper part being pivoted to a pin, B⁵, affixed to a frame, C, whose upper and lower ends pass through guides C¹, attached to the side pieces of the before-named frame A.

This frame C has other sliding surfaces, C², passing through guides C³, attached also to frame A.

An ordinary scroll-saw, D, is attached to the extremities of these sliding surfaces C², by means of screws or such-like devices.

A brace, E, of suitable construction, and of a curved shape, is attached to the frame A by means of rivets or such-like devices, said brace E being of such proportions as it will project from the frame A and pass underneath an ordinary workshop-bench, E¹, to which it is affixed by screws or clamps, said bench E¹ being provided with a slot, E², through which the saw D passes, the whole being so arranged and constructed, that by turning the crank-handle A^b the saw-frame C and scroll-saw D are reciprocated, by means of the described devices.

As heretofore scroll-sawing machines have been constructed, they have been of such design and size as prevent ordinary mechanics from having them, on account of the cost; and as every workshop is not provided with steam-power, ordinary buck or hand-saws have to be resorted to, thus causing loss of time and unnecessary manual labor.

By the use of my devices, lumber can be sawed, resawed, ripped, or cross-cut into any shape; and as the devices are driven by hand-power, and can be attached to and detached from any ordinary workshop-bench, great saving of time and expense will accrue thereby.

I do not claim the separate devices herein described and shown, as I am aware that the same are not new; but as constructed and arranged by me, to form a detachable and portable scroll-saw, they constitute a novel and useful improvement, requiring no special framing or support, and being readily applicable to workshop-requirements, whether driven by hand or power.

What I claim as new, and desire to secure by Letters Patent, is—

The combination of the saw D, saw-frame C, and its driving-mechanism, with the frame A and braces E, when all the parts are constructed substantially as set forth and for the purpose described.

In testimony that I claim the foregoing as my own, I affix my signature, in presence of two witnesses.

JAMES M. BLACKSTOCK.

Witnesses:

PERCEVAL BECKETT,
JOHN P. CLARK.