

(12) INTERNATIONAL APPLICATION PUBLISHED UNDER THE PATENT COOPERATION TREATY (PCT)

(19) World Intellectual Property Organization
International Bureau



(43) International Publication Date
20 February 2003 (20.02.2003)

PCT

(10) International Publication Number
WO 03/013848 A1

- (51) International Patent Classification⁷: **B32B 15/08**, (74) Agents: **GAUTHIER, Maurice, E.** et al.; Samuels, Gauthier & Stevens LLP, Suite 3300, 225 Franklin Street, Boston, MA 02110 (US).
- (21) International Application Number: PCT/US02/24690 (81) Designated States (*national*): AE, AG, AL, AM, AT, AU, AZ, BA, BB, BG, BR, BY, BZ, CA, CH, CN, CO, CR, CU, CZ, DE, DK, DM, DZ, EC, EE, ES, FI, GB, GD, GE, GH, GM, HR, HU, ID, IL, IN, IS, JP, KE, KG, KP, KR, KZ, LC, LK, LR, LS, LT, LU, LV, MA, MD, MG, MK, MN, MW, MX, MZ, NO, NZ, OM, PH, PL, PT, RO, RU, SD, SE, SG, SI, SK, SL, TJ, TM, TN, TR, TT, TZ, UA, UG, UZ, VN, YU, ZA, ZM, ZW.
- (22) International Filing Date: 5 August 2002 (05.08.2002)
- (25) Filing Language: English
- (26) Publication Language: English
- (30) Priority Data:
60/311,187 9 August 2001 (09.08.2001) US
10/017,490 14 December 2001 (14.12.2001) US
- (71) Applicant: **FLEXCON COMPANY, INC.** [US/US]; 1 Flexcon Industrial Park, Spencer, MA 01562 (US).
- (72) Inventors: **SEGALL, Daniel, P.**; 143 Deepwoods Drive, Longmeadow, MA 01106 (US). **HILTON, Iris, E.**; 10 Schoolhouse Road, Charlton, MA 01507 (US). **FALES-BOND, Sharon, A.**; 25 Gay Street, Brookfield, MA 01506 (US). **PENNACE, John, R.**; 2 Knollwood Road, Paxton, MA 01612 (US).
- (84) Designated States (*regional*): ARIPO patent (GH, GM, KE, LS, MW, MZ, SD, SL, SZ, TZ, UG, ZM, ZW), Eurasian patent (AM, AZ, BY, KG, KZ, MD, RU, TJ, TM), European patent (AT, BE, BG, CH, CY, CZ, DE, DK, EE, ES, FI, FR, GB, GR, IE, IT, LU, MC, NL, PT, SE, SK, TR), OAPI patent (BF, BJ, CF, CG, CI, CM, GA, GN, GQ, GW, ML, MR, NE, SN, TD, TG).
- Published:**
— with international search report
- For two-letter codes and other abbreviations, refer to the "Guidance Notes on Codes and Abbreviations" appearing at the beginning of each regular issue of the PCT Gazette.*

(54) Title: CONDUCTIVE COMPOSITE MATERIAL

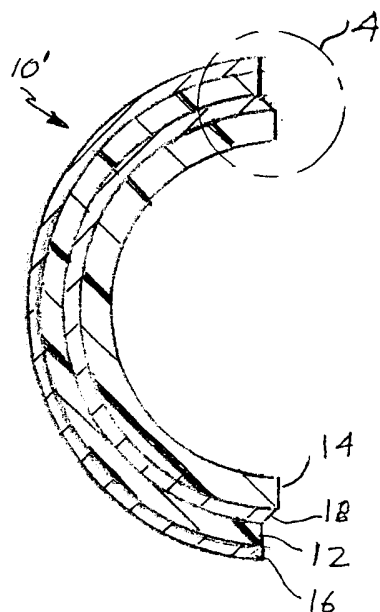

(57) Abstract: An electrically conductive multilayer composite comprises first and second polymeric films, each being flexible and having upper and lower surfaces, with the second films being thermoformable at temperatures at and above its glass transition temperature. A flexible electrically conductive layer is applied to the upper surface of the first films, and an adhesive interlayer adheres the lower surface of the first film to the upper surface of the second film. The adhesive interlayer has elastic properties sufficient to accommodate relative movement between the thus adhered films occasioned by flexure of the composite.

WO 03/013848 A1

CONDUCTIVE COMPOSITE MATERIAL

CROSS REFERENCE TO RELATED APPLICATION

5 This application claims priority from U.S. Patent Application Serial No. 10/017,490 filed December 14, 2001, and Provisional Patent Application Serial No. 60/311,187 filed August 9, 2001, which is incorporated herein by reference in its entirety.

10

BACKGROUND OF THE INVENTION1. Field of the Invention

 This invention relates to electrically conductive materials useful in the formation
15 of EMI/RFI shielding gaskets and the like.

2. Description of the Prior Art

 It is known to form EMI/RFI shielding gaskets from metal alloys such as metal phosphate and beryllium copper, the latter being the most widely used. Such alloys are
20 relatively expensive. Moreover, in a Hazard Information Bulletin published by the Occupational Safety and Health Administration on September 2, 1999, exposure to beryllium has been cited as a cause of chronic beryllium disease (CBD), a disabling and often fatal lung disease. It appears likely, therefore, that the use of alloys containing beryllium may eventually be severely curtailed, if not banned.

25 It is also known to form EMI/RFI gaskets from composites comprising metallic foils bonded to polymeric substrates. While such composites are less expensive than the above mentioned metal alloys, experience has indicated that either during formation into gaskets, or subsequently during repeated flexure of the gaskets, the metallic foils tend to crease, crack or pull away from the polymeric substrates.

30 The objective of the present invention is to provide an improved electrically conductive composite material that overcomes the shortfalls of the previously developed composites, and is both relatively inexpensive as compared to metal alloys, and readily formable into gaskets and other like EMI/RFI shielding components.

SUMMARY OF THE INVENTION

In accordance with the present invention, first and second polymeric films are provided, each being flexible and having upper and lower surfaces, with the second film being thermoformable at temperatures at and above its glass transition temperature. A flexible electrically conductive layer is applied to the upper surface of the first film, and the lower surface of the first film is adhered to the upper surface of the second film by an adhesive interlayer. The adhesive interlayer has elastic properties sufficient to accommodate relative movement between the thus adhered films occasioned by flexure of the composite. The relative movement between the first and second films during flexure of the composite serves to safeguard the electrically conductive layer from creasing, cracking or pulling away from the upper surface of the first film.

In addition to being thermoformable, the second film also may be resilient. Additional films may be included in the composite, and a second flexible electrically conductive layer may be applied to the side of the composite opposite to that to which the first conductive layer is applied.

These and other features and objective so the present invention will now be described in greater detail with reference to the accompanying drawings, wherein:

BRIEF DESCRIPTION OF THE DRAWINGS:

Figure 1 is a sectional view taken through one embodiment of an electrically conductive multilayer composite in accordance with the present invention, it being understood that this view is greatly enlarged with the relative dimensions of components exaggerated for illustrative purposes;

Figure 2 is an exploded view of the composite shown in Figure 1;

Figure 3 is a view showing the composite after it has been thermoformed into a shaped non-planar configuration;

Figure 4 is an enlarged view of the circled portion of Figure 5;

Figure 5 is a view showing the composite contoured to the shape of a substrate;

Figure 6 is a view showing the composite resiliently bridging the gap between two mutually spaced relatively movable components;

Figure 7 is a view of an alternative embodiment having electrically conductive layers applied to both sides; and

5 Figure 8 is an illustration of the test procedure used to evaluate the performance of composites in accordance with the present invention.

DETAILED DESCRIPTION OF PREFERRED EMBODIMENTS

10

With reference initially to Figures 1 and 2, an electrically conductive multilayer composite in accordance with one embodiment of the present invention is shown at 10. The composite includes first and second flexible polymeric films 12, 14. Film 12 has upper and lower surfaces 12a, 12b, and film 14 also has upper and lower surfaces 14a, 15 14b. Film 14 is thermoformable at temperatures at and above its glass transition temperature.

A flexible electrically conductive layer 16 is applied to the upper surface 12a of film 12, and an adhesive interlayer 18 adheres the lower surface 12b of film 12 to the upper surface 14a of film 14.

20 The electrically conductive layer 16 is selected from the group consisting of copper, aluminum, nickel, tin, silver, gold, ferrous metals and alloys thereof. The electrically conductive layer may be applied as a foil adhered to the upper surface 12a of film 12 by an adhesive (not shown), or it may comprise a coating applied by known techniques, including for example electroplating, non-electrode deposition, vacuum 25 deposition, plasma deposition, sputter deposition, etc. In all cases, the layer 16 advantageously will be relatively thin, preferably not more than 20 mils in thickness, and it will be securely anchored to the upper film surface 12a. The film 12 supports and stabilizes the electrically conductive layer 16, and in so doing resists creasing, cracking, or separation of the electrically conductive layer from the film surface 12a.

30 The polymeric materials of the films 12, 14 may be selected from the group consisting of polyesters, polyamides, polyimides, polyurethanes, polyethylenesulfones, polybutenes, and derivatives, polycarbonates, polystyrene, (and copolymers containing styrene) polyethylene (linear), polyethyleneketones,

polyacrylates (including methacrylates), rigid PVC (and copolymers). Preferably, the bulk modulus of elasticity of film 14 is higher than that of film 12.

The adhesive of interlayer 18 is preferably pressure sensitive, examples being those identified by the product designations V-402, V-23, V-106, V-95, V-98, V-156 and Densil, all of which are available from FLEXcon, Inc. of Spencer, Massachusetts, U.S.A. Such adhesives exhibit elastic properties at temperatures ranging from -50 to 150°C.

The composite 10 may be heated to an elevated temperature at or above the glass transition temperature of film 14, then flexed and formed into a shaped configuration as shown for example at 10' in Figure 3, and then cooled below the glass transition temperature of film 14 to retain the thus shaped configuration. Flexure of the composite as a result of shaping will occasion relative displacement of the films 12, 14, as reflected by the edge offset "x" illustrated in Figure 4. The elastic properties of the adhesive interlayer 18 are sufficient to accommodate such relative movement between the films, during initial shaping as well as subsequently, when the thus shaped composite is subjected to repeated flexure, with the result that minimal stress is placed on the electrically conductive layer 16 anchored to the upper surface 12a of film 12.

The composite 10 may be thermoformed into various shapes. For example, and as shown in Figure 5, the composite may be contoured to the shape of a substrate such as the outer housing 20 of a cell phone, thus serving to shield the user from RFI generated by the phone.

As shown in Figure 6, in cases where the second film 14 is comprised of a polymer that is both thermoformable and resilient, for example polyester, the composite 10' may be utilized as an EMI/RFI shielding gasket bridging the gap between components 22, 24 that are movable toward and away from each other. The gasket will respond to relative movement of the components 22, 24 by flexing resiliently, with the elastic properties of the adhesive interlayer 18 again accommodating relative movement between the first and second films 12, 14.

In a further embodiment as shown in Figure 7, a second conductive layer 26 may be applied to a third film 28, and the third film may be adhered to the bottom surface 14b of the second film 14 by a second adhesive interlayer 30 having elastic properties sufficient to accommodate relative movement between the second and third films occasioned by flexure of the composite when employed, for example, in a switch

or the like.

Example 1

5 An electrically conductive multilayer composite was formed by initially employing a thermoset adhesive (Devcon 5 minute Epoxy supplied by the Consumer Division of ITW Performance Polymers of Riviera Beach, Florida) to adhere a 0.7 mil copper foil to the upper surface of a 1.0 mil polyester "first" film. The lower surface of the first film was then adhered to the upper surface of a 4.0 mil polyester "second" film by means of a pressure sensitive adhesive (FLEXcon's V-402).

10 The composite was then thermoformed into a semicircular cross-sectional profile 10' as shown in Figures 3 and 6, having an inner diameter of 0.75 inches. This was accomplished by bending the composite around a cylindrical support heated to a temperature of 250°F and maintaining the composite in this position for 60 seconds, followed by cooling to ambient temperatures.

15 As depicted in Figure 8, the thus formed composite 10' was then supported on a flat surface S and repeatedly flexed to a nearly flat condition as shown by the broken lines at 10". Flexure was achieved in cycles by applying and releasing a downward force F at one second intervals. After 100 cycles, the copper foil remained smooth and securely adhere to the underlying film, with no signs of creasing or cracking.

20

Example 2

Aluminum was vacuum deposited to a thickness of 1.5-2.0 microns on the upper surface of a 1.0 mil polyester first film, and the lower surface of the first film was adhered to the upper surface of a 4.0 mill polyester second film by means of a pressure sensitive adhesive (FLEXcon's V-402). The resulting composite was then thermoformed and tested in accordance with the procedures described in Example 1. After 100 test cycles, the aluminum remained smooth and securely adhered to the underlying film, with no signs of splitting or cracking.

Comparative Example 1

30 A thermoset adhesive was used to adhere a 0.7 mil copper foil to the upper surface of a 4.0 mil polyester film. The thermoset adhesive, copper foil and film were the same as those employed in Example 1. The resulting composite was then thermoformed and tested through repeated cycles, also in accordance with the

procedures described in Example 1. After only five test cycles, the copper foil exhibited serious cracking.

Comparative Example 2

5 A pressure sensitive adhesive (V-402) was used in place of a thermoset adhesive to form the composite of Comparative Example 1. The resulting composite was thermoformed and tested through repeated cycles, in accordance with the procedures described in Example 1. After two test cycles, the copper foil exhibited creases and “piping” (pulling away from the underlying film), and at about 20 test cycles,
10 continued creasing caused the foil to begin splitting.

Comparative Example 3

Aluminum was vacuum deposited to a thickness of 1.5-2.0 microns on the silicone coated surface of a polyester carrier film. The aluminum deposit was then
15 transferred from the carrier film and adhered to the surface of a 4.0 mil polyester film by means of a pressure sensitive adhesive (FLEXcon’s V-402). The composite was thermoformed and tested in accordance with the procedures described in Example 1. Metal splitting was observed within ten test cycles.

In light of the foregoing, it will be seen that the interposition of a film 12 and
20 adhesive interlayer 18 between the metallic layer 16 and support film 14, combined with the elastic properties of the adhesive interlayer, serves to beneficially stabilize and protect the metallic layer from damage caused by repeated flexure of the composite.

We claim:

CLAIMS

- 1 1. An electrically conductive multilayer composite comprising:
2 first and second polymeric films, each of said films being flexible and having
3 upper and lower surfaces, said second film being thermoformable at temperatures at
4 and above its glass transition temperature;
5 a flexible electrically conductive layer applied to the upper surface of said first
6 film; and
7 an adhesive interlayer adhering the lower surface of said first film to the upper
8 surface of said second film, said adhesive interlayer having elastic properties sufficient
9 to accommodate relative movement between the thus adhered films occasioned by
10 flexure of said composite.
- 1 2. The composite of claim 1 wherein said second film is resilient.
- 1 3. The composite of claim 2 wherein said adhesive interlayer has elastic
2 properties at temperatures between about -50 to 150°C.
- 1 4. The composite of claims 1 or 2 wherein said electrically conductive
2 layer comprises a metallic foil adhered to the upper surface of said first film by means
3 of a second adhesive.
- 1 5. The composite of claims 1 or 2 wherein said adhesive interlayer is
2 pressure sensitive.
- 1 6. The composite of claim 2 wherein said second film has a higher bulk
2 modulus of elasticity than that of said first film.
- 1 7. The composite of claims 1 or 2 further comprising a third flexible
2 polymeric film adhered to the lower surface of said second film by a second adhesive
3 interlayer.
- 1 8. The composite of claims 2 or 7 further comprising a second flexible
2 electrically conductive layer applied to the side of said composite opposite to that to
3 which said first mentioned electrically conductive layer is applied.
- 1 9. The composite of claims 1 or 2 wherein said electrically conductive
2 layer is selected from the group consisting of copper, aluminum, nickel, tin, silver,

3 gold, ferrous metals and alloys thereof.

1 10. The composite of claims 1 or 2 wherein said electrically conductive
2 layer has a thickness of not more than about 20 mil.

1 11. The composite of claims 1 or 2 wherein the polymeric materials of said
2 first and second films are selected from the group consisting of polyesters, polyamides,
3 polyimides, polyurethanes, polyethylenesulfones, polybutenes, and derivatives,
4 polycarbonates, polystyrene, (and copolymers containing styrene) polyethylene
5 (linear), polyethyleneketones, polyacrylates (including methacrylates), rigid PVC
6 (and copolymers).

1 12. The composite of claims 1 or 2 wherein said electrically conductive
2 layer is interfacially fixed with respect to the upper surface of said first film.

1 13. A method of preparing an electrically conductive multilayer composite
2 comprising:

3 a) providing first and second polymeric films, each of said films being
4 flexible and having upper and lower surfaces, said second film being thermoformable
5 at temperatures at and above its glass transition temperature;

6 b) applying a flexible electrically conductive layer to the upper surface of
7 said first film; and

8 (c) adhering the lower surface of said first film to the upper surface of said
9 second film by means of an adhesive interlayer that has elastic properties sufficient to
10 accommodate relative movement between the thus adhered films occasioned by flexure
11 of said composite.

1 14. A method of preparing a shaped electrically conductive component, said
2 method comprising:

3 a) preparing a multilayer composite by:

4 (i) providing first and second polymeric films, each of said films
5 being flexible and having upper and lower surfaces, with at least said second
6 film being thermoformable at temperatures at and above its glass transition
7 temperature;

8 (ii) applying a flexible electrically conductive layer to the upper
9 surface of said first film; and

10 (iii) adhering the lower surface of said first film to the upper surface
11 of said second film by means of an adhesive interlayer that has elastic properties
12 sufficient to accommodate relative movement between the thus adhered films
13 occasioned by flexure of said composite.

14 b) heating said composite to an elevated temperature at least as high as the
15 glass transition temperature of said second film;

16 c) shaping the thus heated composite into a selected shape; and

17 d) cooling the thus shaped composite to a temperature below said elevated
18 temperature.

1 15. The method of claims 13 or 14 wherein the second film is resilient.

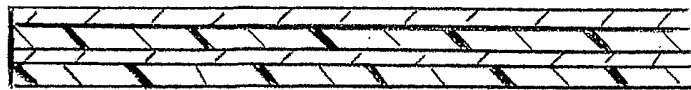

FIG. 1

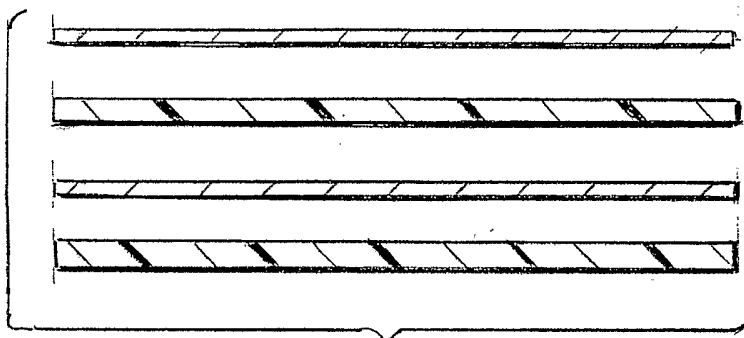

FIG. 2

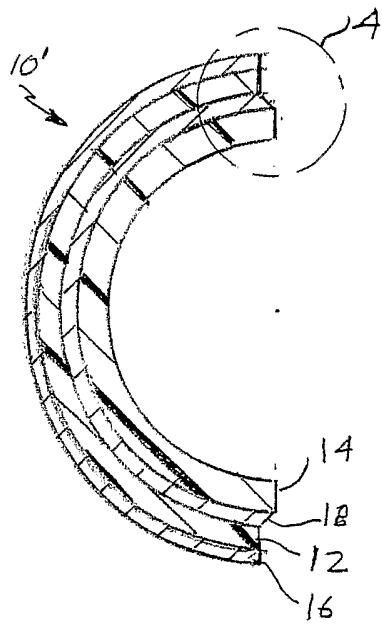

FIG. 3

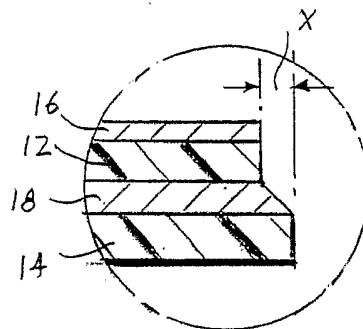

FIG. 4

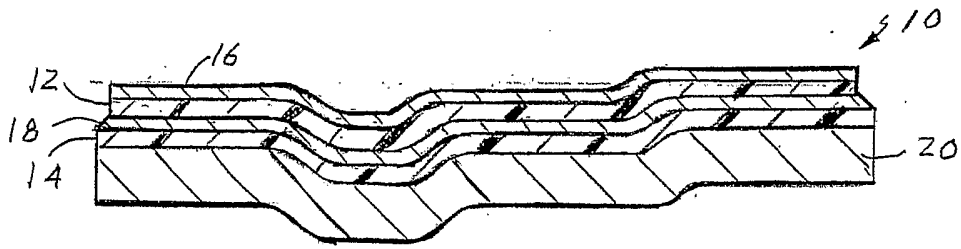

FIG. 5

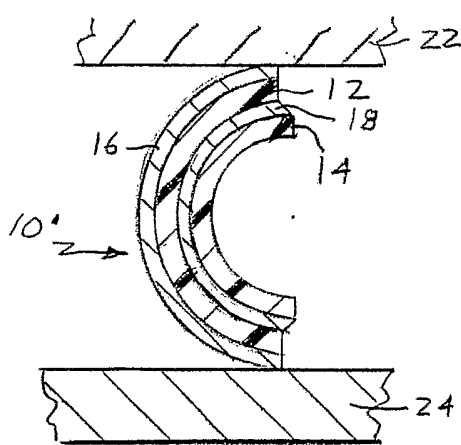

FIG. 6

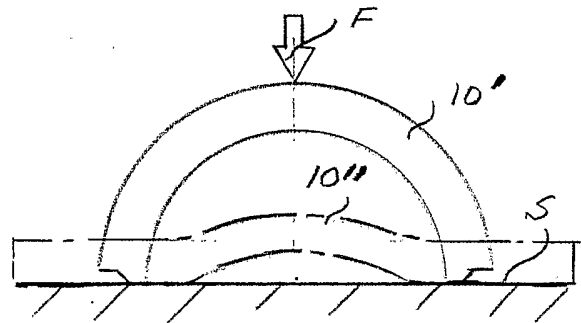

FIG. 8

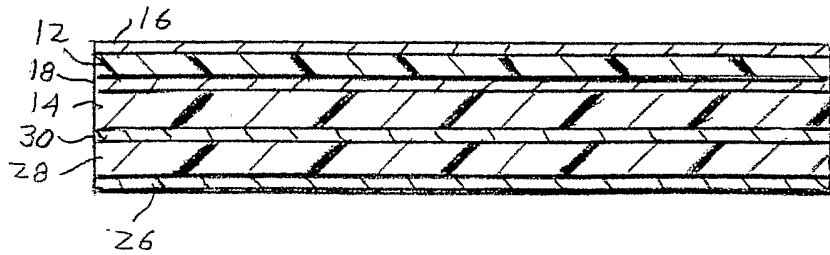

FIG. 7

INTERNATIONAL SEARCH REPORT

national Application No.
PCT/US 02/24690A. CLASSIFICATION OF SUBJECT MATTER
IPC 7 B32B15/08 B32B27/08

According to International Patent Classification (IPC) or to both national classification and IPC

B. FIELDS SEARCHED

Minimum documentation searched (classification system followed by classification symbols)
IPC 7 B32B

Documentation searched other than minimum documentation to the extent that such documents are included in the fields searched

Electronic data base consulted during the international search (name of data base and, where practical, search terms used)

EPO-Internal, WPI Data

C. DOCUMENTS CONSIDERED TO BE RELEVANT

Category ^o	Citation of document, with indication, where appropriate, of the relevant passages	Relevant to claim No.
X	WO 97 37054 A (MOBIL OIL CORP) 9 October 1997 (1997-10-09) claims page 3, line 23 -page 6, line 31 ----	1-15
X	WO 96 20827 A (BENTLEY HARRIS INC ;T & N PLC (GB)) 11 July 1996 (1996-07-11) claims 1-4,7-13 ----	1-3,9-13
X	DE 30 15 387 A (METALL PLASTIK GMBH & CO KG) 1 April 1982 (1982-04-01) claims ----	1-3,9-13
X	US 5 665 469 A (BRANDT RAINER ET AL) 9 September 1997 (1997-09-09) claims; examples -----	1-3,9-13

 Further documents are listed in the continuation of box C. Patent family members are listed in annex.^o Special categories of cited documents :

A document defining the general state of the art which is not considered to be of particular relevance

E earlier document but published on or after the international filing date

L document which may throw doubts on priority claim(s) or which is cited to establish the publication date of another citation or other special reason (as specified)

O document referring to an oral disclosure, use, exhibition or other means

P document published prior to the international filing date but later than the priority date claimed

T later document published after the international filing date or priority date and not in conflict with the application but cited to understand the principle or theory underlying the invention

X document of particular relevance; the claimed invention cannot be considered novel or cannot be considered to involve an inventive step when the document is taken alone

Y document of particular relevance; the claimed invention cannot be considered to involve an inventive step when the document is combined with one or more other such documents, such combination being obvious to a person skilled in the art.

& document member of the same patent family

Date of the actual completion of the international search

13 November 2002

Date of mailing of the international search report

20/11/2002

Name and mailing address of the ISA

European Patent Office, P.B. 5818 Patentlaan 2
NL - 2280 HV Rijswijk
Tel. (+31-70) 340-2040, Tx. 31 651 epo nl,
Fax: (+31-70) 340-3016

Authorized officer

De Jonge, S

INTERNATIONAL SEARCH REPORT
Information on patent family members

International Application No
PCT/US 02/24690

Patent document cited in search report		Publication date	Patent family member(s)	Publication date
WO 9737054	A	09-10-1997	US 5688556 A	18-11-1997
			AU 705485 B2	20-05-1999
			AU 2554797 A	22-10-1997
			BR 9708582 A	03-08-1999
			CA 2249394 A1	09-10-1997
			CN 1214741 A	21-04-1999
			EP 0958399 A1	24-11-1999
			JP 2000507518 T	20-06-2000
			KR 2000005140 A	25-01-2000
			WO 9737054 A1	09-10-1997
WO 9620827	A	11-07-1996	BR 9510435 A	07-07-1998
			CA 2208255 A1	11-07-1996
			CN 1171079 A ,B	21-01-1998
			DE 69515908 D1	27-04-2000
			DE 69515908 T2	12-10-2000
			EP 0800452 A1	15-10-1997
			ES 2143667 T3	16-05-2000
			WO 9620827 A1	11-07-1996
			JP 10511900 T	17-11-1998
			US 5718956 A	17-02-1998
DE 3015387	A	01-04-1982	DE 3015387 A1	01-04-1982
US 5665469	A	09-09-1997	DE 4443458 A1	13-06-1996
			EP 0715952 A2	12-06-1996