



US00D855019S

(12) **United States Design Patent**
Rustill

(10) **Patent No.:** **US D855,019 S**

(45) **Date of Patent:** **** Jul. 30, 2019**

(54) **BATTERY CHARGER**

(71) Applicant: **7RDD Limited**, North Yorkshire (GB)

(72) Inventor: **Neal Aaron Rustill**, Yorkshire (GB)

(73) Assignee: **7RDD LIMITED**, Dunnington, York (GB)

(**) Term: **15 Years**

(21) Appl. No.: **29/596,587**

(22) Filed: **Mar. 9, 2017**

(51) **LOC (11) Cl.** **13-02**

(52) **U.S. Cl.**
USPC **D13/108**

(58) **Field of Classification Search**
USPC D13/107-110, 118-119, 184; D14/251, D14/253, 432, 434
CPC Y02E 60/12; Y02T 90/14; Y02T 90/122; Y02T 90/128; Y02T 90/163; H02J 7/025; H02J 7/0042; H02J 7/0044; H02J 7/0045; H02J 7/0003; H01F 38/14; H01R 13/6675; H01M 10/44; H01M 10/46; H01M 10/425; H01M 2/1022; H01M 2/1055; B60L 11/182

See application file for complete search history.

(56) **References Cited**

U.S. PATENT DOCUMENTS

D506,972 S * 7/2005 Parel D13/107
D507,234 S * 7/2005 Heun D13/107

D605,111 S * 12/2009 Schoch D13/107
D610,085 S * 2/2010 Sweeney D13/107
D633,037 S * 2/2011 Tschopp D13/107
D652,793 S * 1/2012 Tschopp D13/107
D711,314 S * 8/2014 Marino D13/107
D711,317 S * 8/2014 Zhou D13/108
D723,458 S * 3/2015 Martinez D13/108
D766,177 S * 9/2016 Barajas D13/107
D775,587 S * 1/2017 Barajas D13/107
9,728,822 B2 * 8/2017 Taga H01M 10/6563
9,966,772 B2 * 5/2018 Uesugi H02J 7/0026

* cited by examiner

Primary Examiner — Rosemary K Tarcza

Assistant Examiner — Nathaniel D. Buckner

(74) *Attorney, Agent, or Firm* — Woodard, Emhardt, Henry, Reeves & Wagner, LLP

(57) **CLAIM**

The ornamental design for a battery charger, as shown and described.

DESCRIPTION

FIG. 1 is perspective view of a battery charger showing my new design;
FIG. 2 is a right view thereof;
FIG. 3 is a left view thereof;
FIG. 4 is a front view thereof;
FIG. 5 is a rear view thereof;
FIG. 6 is a top view; and,
FIG. 7 is a bottom view thereof.
The broken lines in the figures depict portions of the article which form no part of the claimed design.

1 Claim, 4 Drawing Sheets

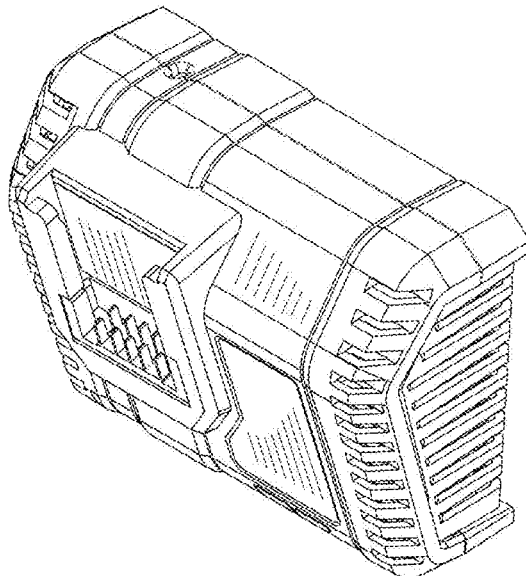

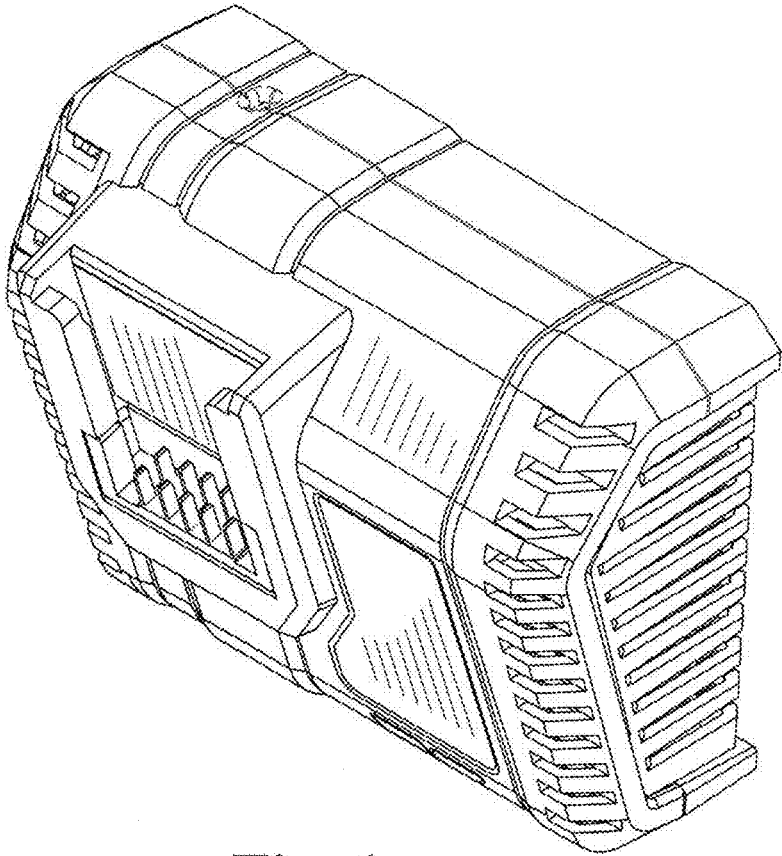

Fig. 1

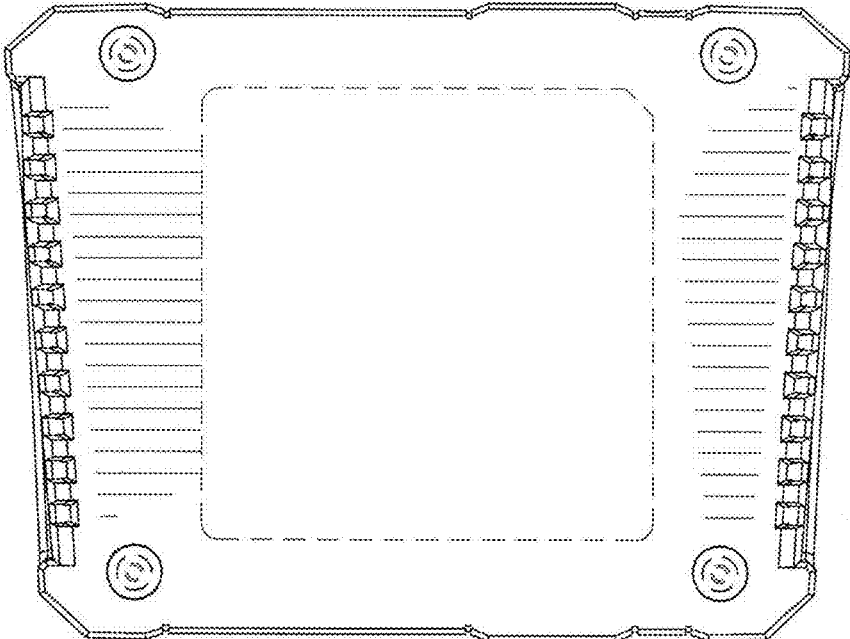

Fig. 2

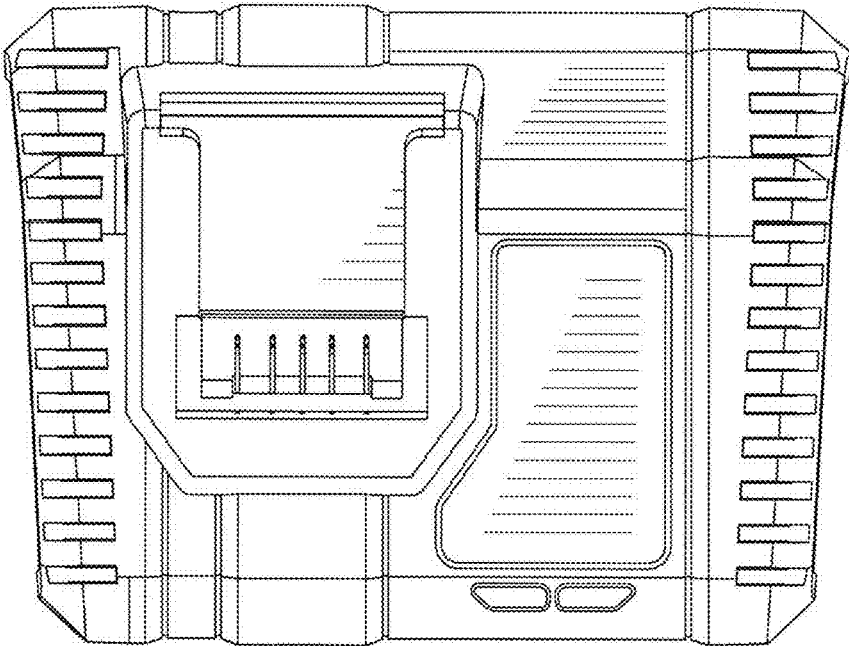

Fig. 3

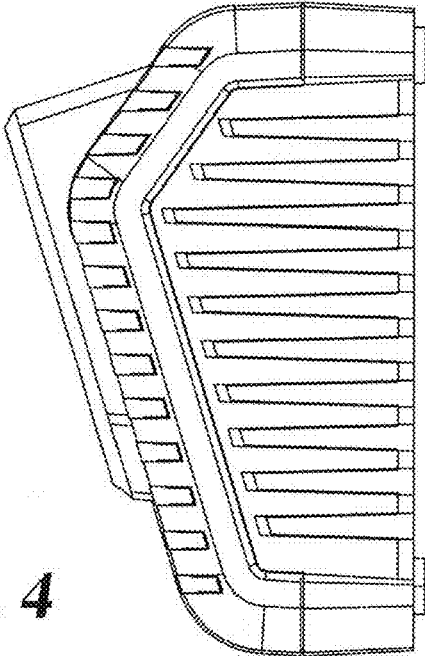

Fig. 4

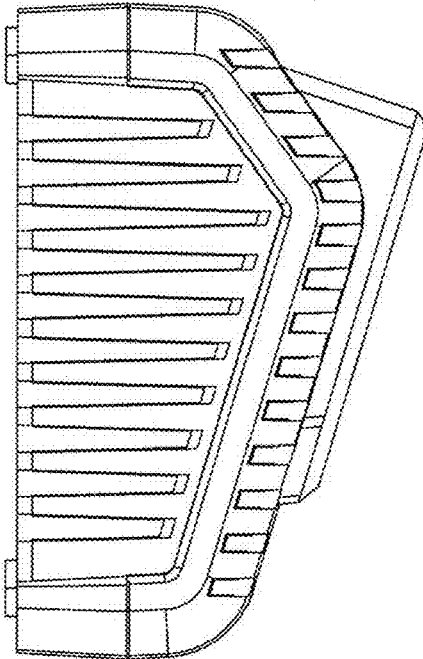

Fig. 5

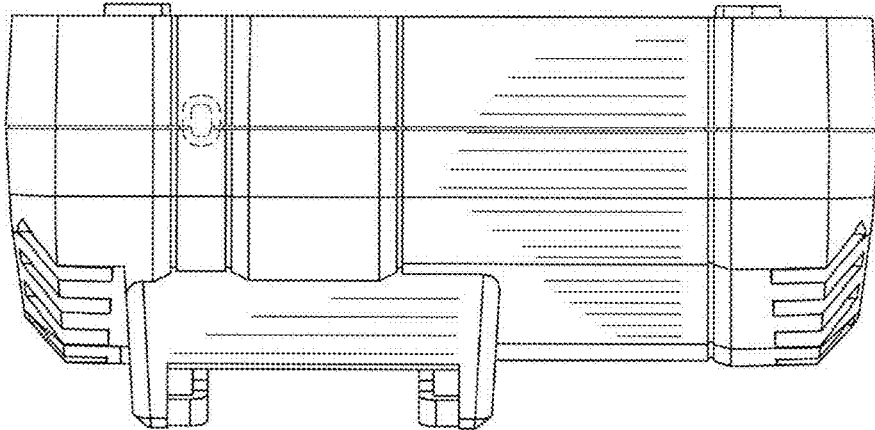

Fig. 6

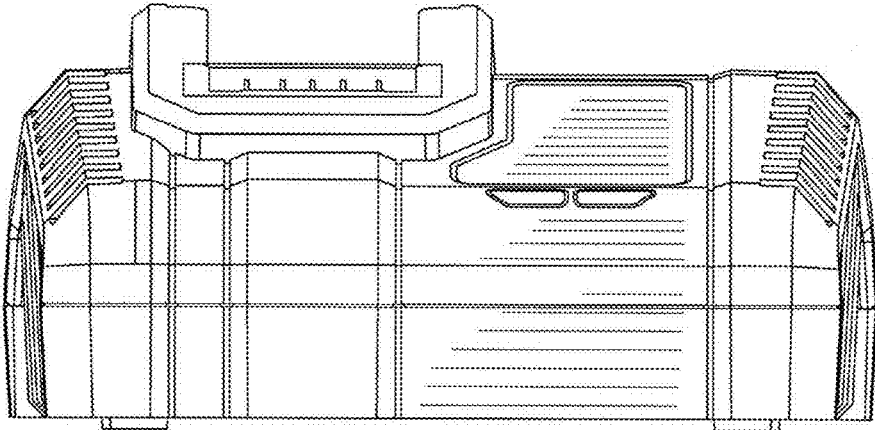

Fig. 7