



(19) **United States**

(12) **Patent Application Publication**
Hendricks

(10) **Pub. No.: US 2004/0128733 A1**

(43) **Pub. Date: Jul. 8, 2004**

(54) **MODULAR SWIMWEAR**

(52) **U.S. Cl. 2/69**

(76) **Inventor: Glen J. Hendricks, West Orange, NJ (US)**

(57) **ABSTRACT**

Correspondence Address:
John D. Long
2941 Sage Ridge Drive
Reno, NV 89509 (US)

Swimwear containing at least one detachable panel having at least two sides, with each side of each panel featuring different colors, and/or different textures and/or different designs/indicia allowing the wearer to create a different "look" for the swimwear by detaching, inverting and reattaching the panel. For swimwear having multiple similar panels, the panels may be detached and reattached/arranged to produce a mirror image of the original set of the swim wear. The invention additionally provides for swapping of panels from similarly constructed swimwear, so that the wearer can detach, arrange and reattach the panels to create sets of swimwear with a multitude of different appearances. The invention can be applied to clothing with the capacity of being similarly constructed with detachable panels. Such additional embodiments of the invention could be applied to non-swimwear such as women's underwear such as panties and brassieres or women's other clothing such as Bandeau top.

(21) **Appl. No.: 10/728,294**

(22) **Filed: Dec. 3, 2003**

Related U.S. Application Data

(60) **Provisional application No. 60/431,218, filed on Dec. 4, 2002.**

Publication Classification

(51) **Int. Cl.⁷ A41D 1/00; A41B 1/00**

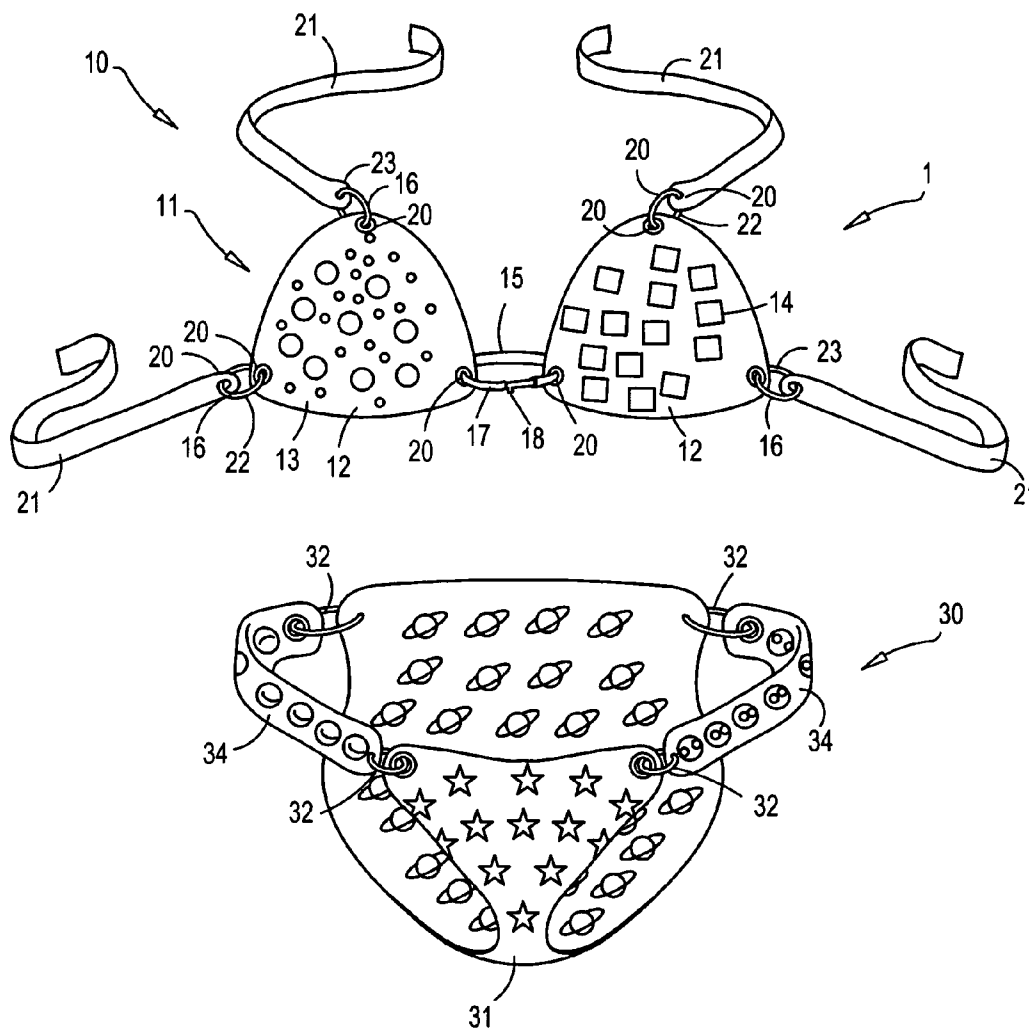

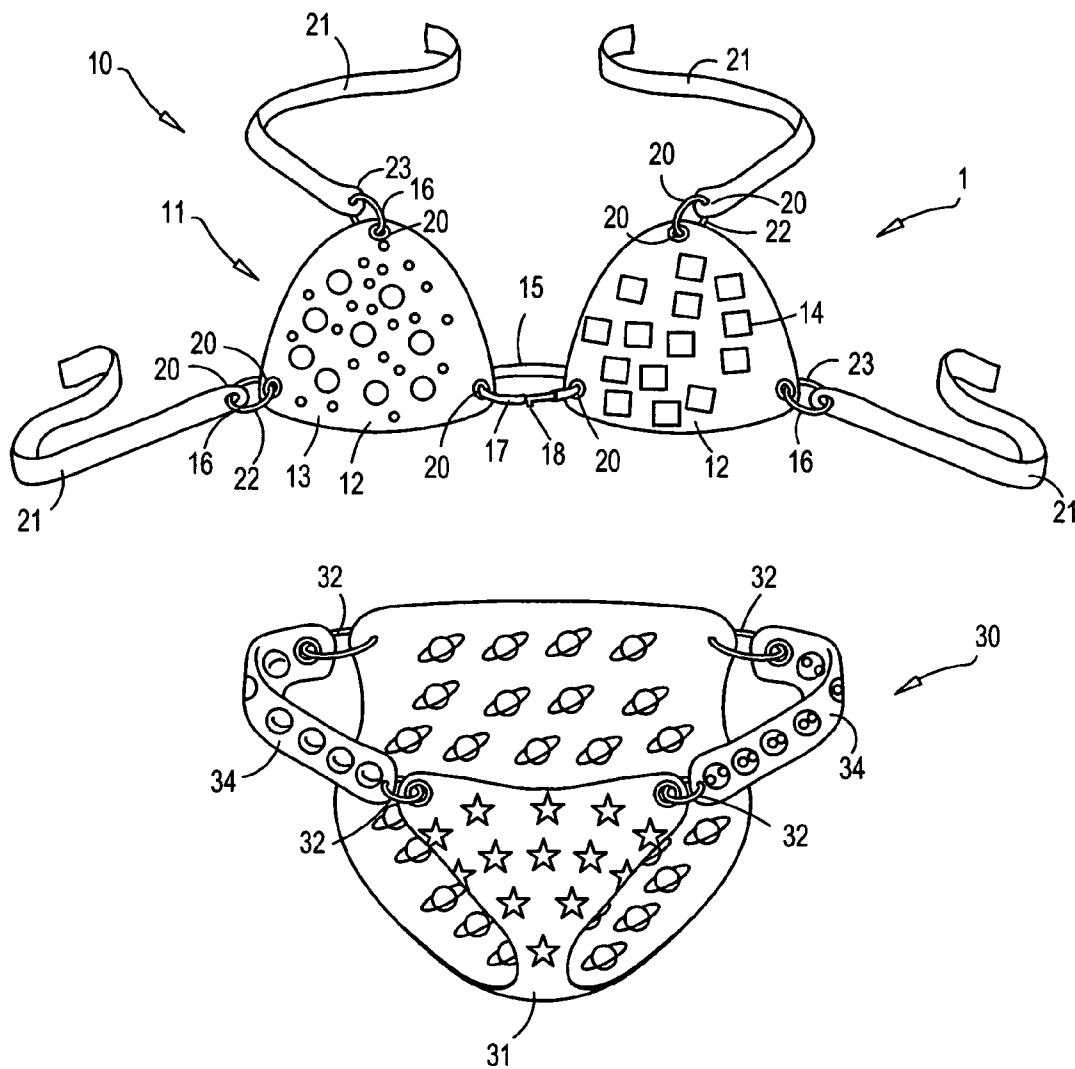

FIG. 1

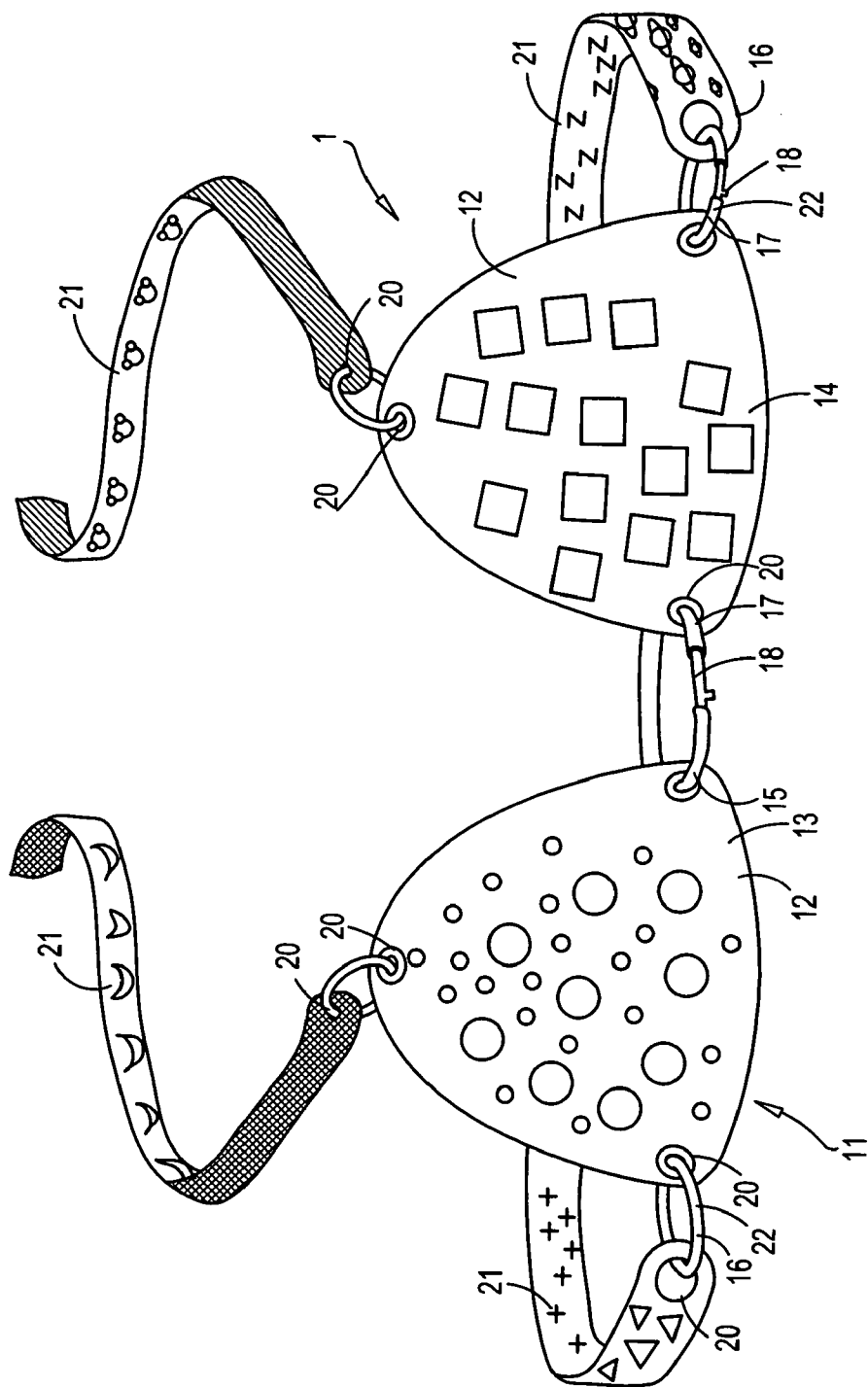

FIG. 2

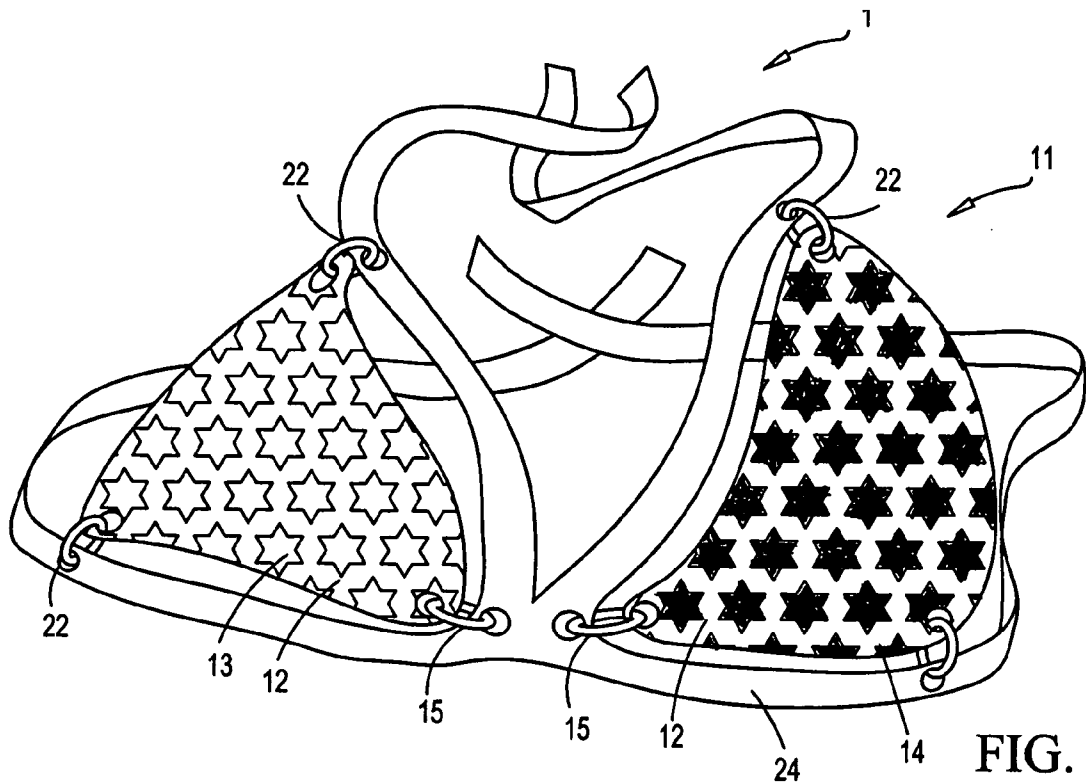

FIG. 3

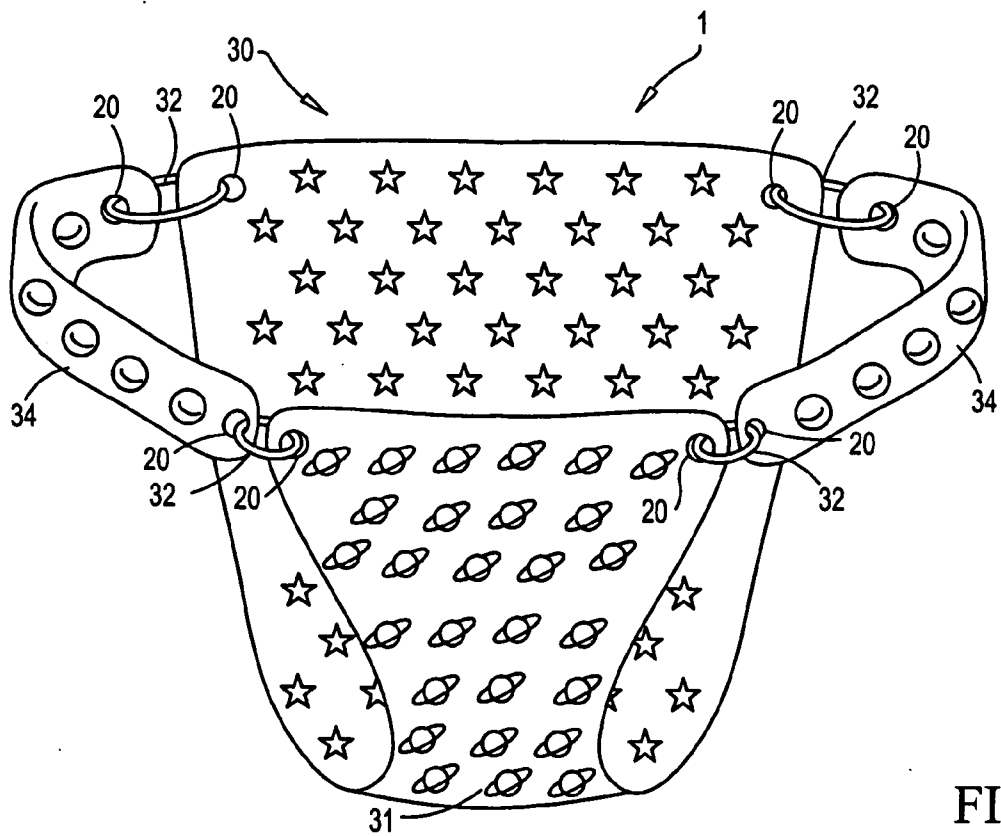

FIG. 4

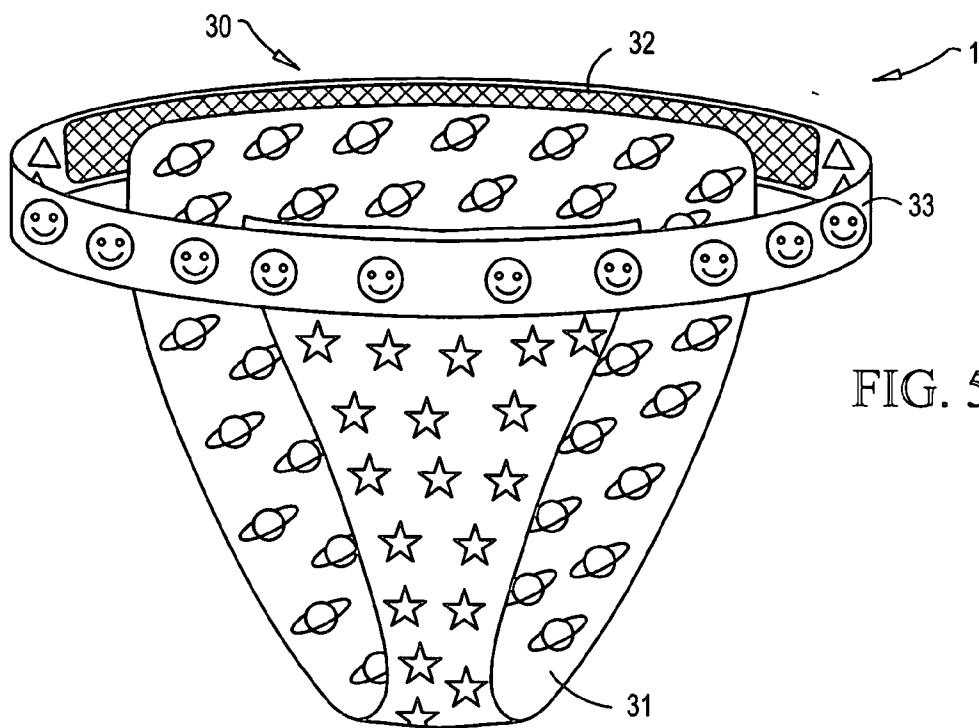

FIG. 5

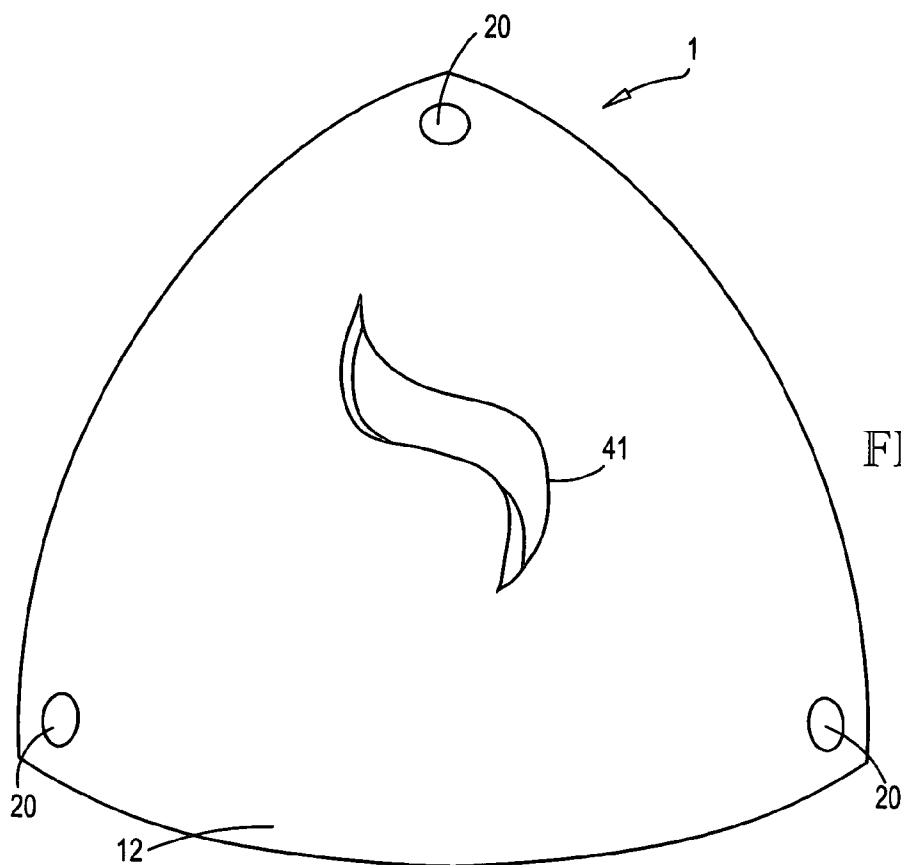

FIG. 6

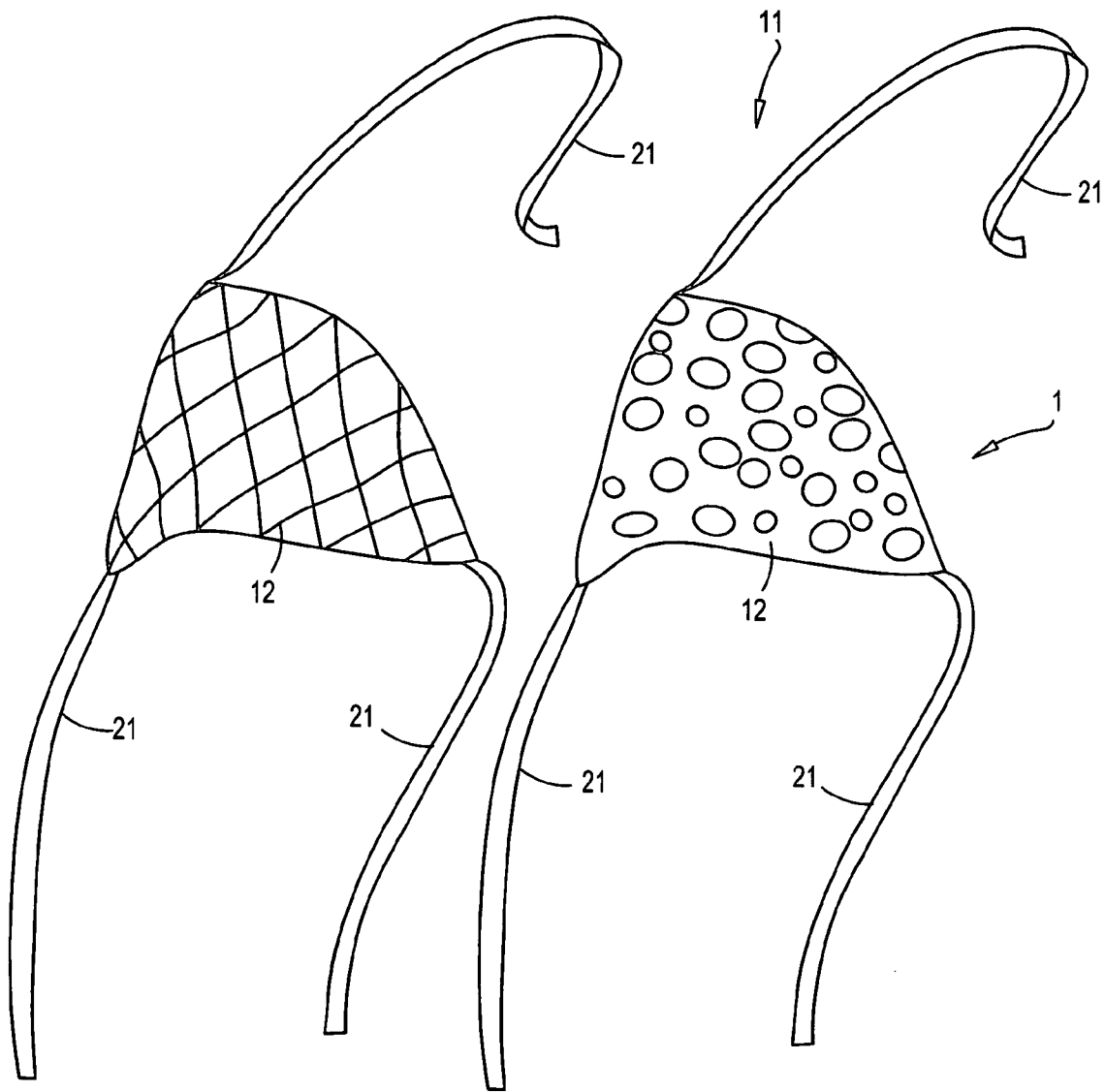
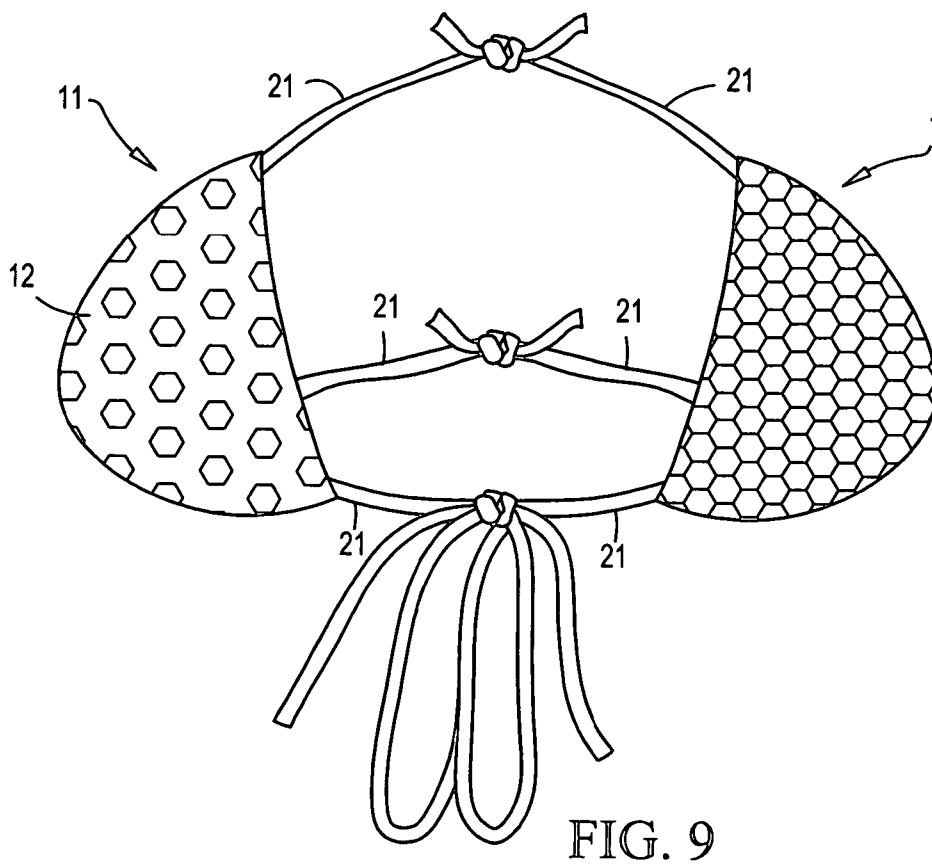
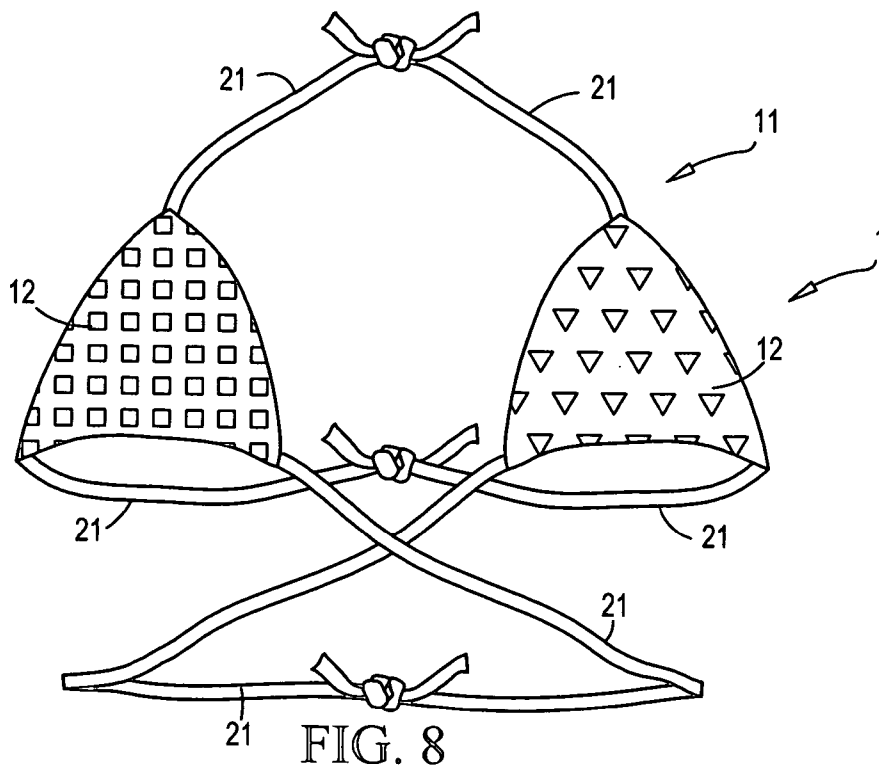

FIG. 7



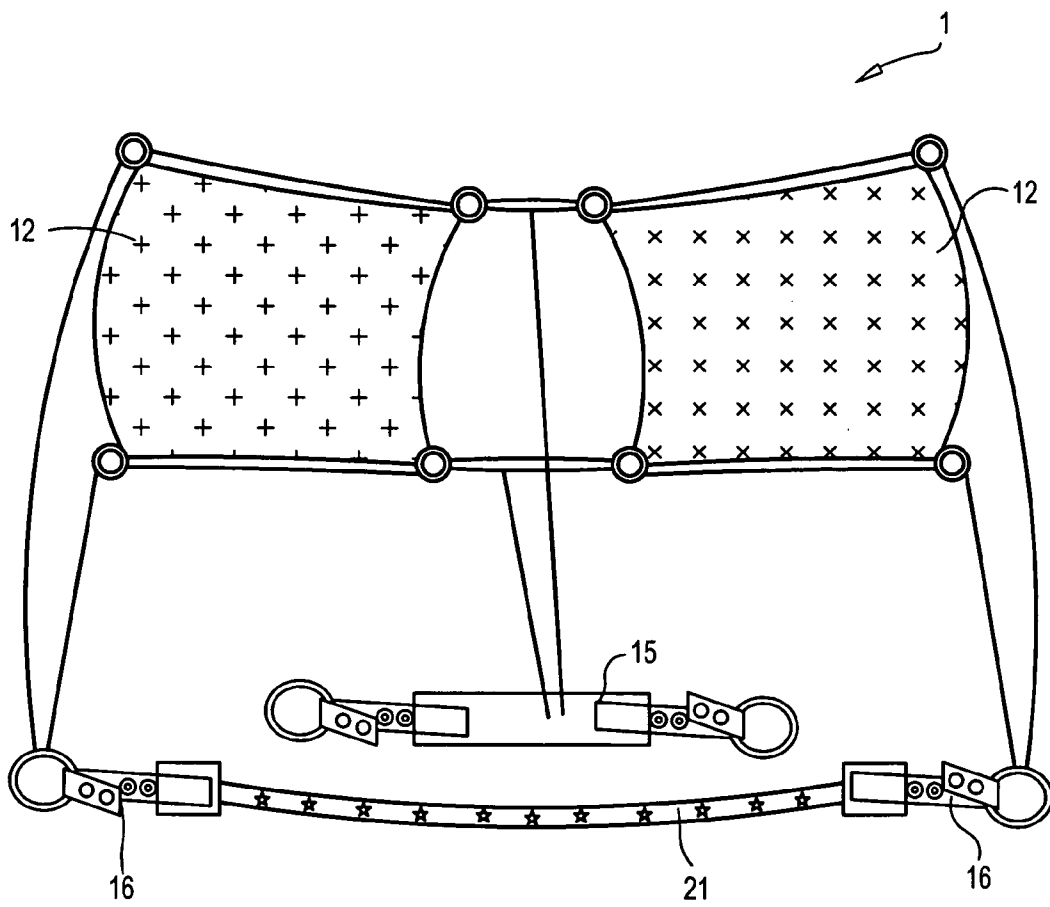

FIG. 10

MODULAR SWIMWEAR**CROSS-REFERENCES TO RELATED APPLICATIONS**

[0001] This application relates to the Applicant's provisional patent application for MODULAR SWIMWEAR, filed on Dec. 4, 2002, Ser. No. 60/431218.

STATEMENT REGARDING FEDERALLY SPONSORED RESEARCH OR DEVELOPMENT

[0002] Not Applicable

REFERENCE TO A "MICROFICHE APPENDIX"

[0003] Not Applicable.

BACKGROUND

[0004] 1. Field of the Invention

[0005] The present invention generally relates to the field of clothing and in particular to clothing for use in water bathing, swimming, sun-bathing, or the like where exposure of the body is desired.

[0006] 2. Description of the Related Art

[0007] Since time immortal, there has been need by the wearer of clothes to personalize an individual's wardrobe so as to make a positive statement of that individual's personality through fashion. This need has been constantly frustrated at any given time worldwide despite the availability of a multitude of styles of clothing differing in shape, color, texture and the like. This frustration is caused, in part due to the economics of the garment and fashion industry which realized greater profits in designing and producing thousands, tens of thousands, of identical garments differing only in size so as to accommodate as many different sized wearers as possible.

[0008] Except for wealthy individuals, the cost of having garments, articles of clothing and other such accouterments individually made to the taste and fitting of each ordinary person generally is prohibitively expensive. The ordinary person is therefore left to obtain clothing of distinction by the means of mixing and matching mass produced garments and such.

[0009] There are several examples in the prior art where clothing can be customized for the individual wearer.

[0010] In US Patent issued to O st et al on Feb. 17, 1998, U.S. Pat. No. 5,718,000, demonstrates a modular all season clothing with detachable sections and layers of clothing so as to suit the environmental needs of the wearer.

[0011] In the US Patent issued to Lurry on Feb. 17, 1998, U.S. Pat. No. 5,717,919, discloses an active wear garment that has sleeves, leggings, a collar and a hood which are detachably connected to vest and pants portions. Garments so constructed to allow the wearer to modify the covering portions of the suit to meet activity or environmental demands. The invention also features detachable design strips which reversibly affix to the garment to allow the user to somewhat individualize to taste the external appearance of the garment.

[0012] In US Patent issued to Heller on Oct. 9, 2001, U.S. Pat. No. 6,298,485 teaches a cycling jersey with different

sized detachable sleeves so as to provide a cyclist, depending on that individuals exercising needs, with a jersey vest, a jersey vest with short sleeves and a jersey vest with long sleeves.

[0013] In United States Patent issued to Luerken, Jun. 14, 1977, U.S. Pat. No. 4,028,740 teaches a two piece (bikini) swimwear that has modesty panels that attach by clips to the lower part of the swimwear. In this manner, the wearer of the garment, when no longer sun bathing or swimming can remove the panels or place them off to the side of the swimwear. The patent also teaches the easy conversion of the panels to permit a variety of color combinations-reversible inside to outside, reversible front to back, etc. The clips through which the panels are attached to the swimwear can incorporate swivels which would facilitate the reversing of the panels to the swimwear. However, the patent only teaches the interchangeability of the additional elements, the modesty panels, to the swimwear, it does not suggest the interchangeability of the parts making up the swimwear itself sans panels.

[0014] Similarly, the United States Patent issued to Estruch, Nov. 15, 1983, U.S. Pat. No. 4,414,691 teaches a reversible bathing garment, such as the two-piece bikini, which has two sides to each of its clothing panels, wherein each side can sport a design different in color, print, etc. from the other side of the panel. In this manner, the bottom piece and/or the top piece each affirming two different designs, can be reversed to provide alternative different designs for both top and bottom pieces of the swimwear.

[0015] The problems with present situation are that the above cited prior art does not allow for full interchangeable portions of the clothing so that the wearer can literally mix and match different panels of garment to attain a truly individualistic clothing. The prior art does not offer any solutions to above problems or properly address them.

SUMMARY OF THE INVENTION

[0016] This invention is a simple and cost effective methodology and apparatus for modular swimwear that is used to cover a private portion of the wearer wherein the wearer can obtain interchangeable modular swimwear that the wearer can mix and match to create an individualistic swimwear of their own design to suit their own fashion and tastes at any particular time.

[0017] In particular, the invention is applied to the two-piece swimming/bath suit generally referred to as the bikini, bustier underwire, bustier underwire halter, bra top underwire, seamed contour, pleated contour, triangle top, T-top, banded sports top, bandeau and then like. The bikini has a top piece garment and bottom piece garment which covers portions of the wearer's chest and groin area, respectively. The top piece is usually comprised of two garments each of which features generally triangular-shapes. These garments cover at least a portion of the wearer's chest and are connected to one another either directly or by straps or by other attaching means. The top piece is generally secured to the chest by straps that can go around the back and neck of the wearer to be secured to one and other.

[0018] The bottom piece (also known as the brazil, thong, Rio bikini, bikini bottom, hip hugger, string bikini, high waist, high waist with "V" belt, athletic with "V" belt,

athletic with shirred belt), is generally a figure-8 shaped piece which the wearer fits the narrow part through her legs so that the wider portion covers her groin area and at least a part of her bottom. In thong style bottom piece, the covering allows a very generous portion of the wearer's bottom to be exposed. The opposing ends of the bottom piece are generally attached to one another by connecting straps that run along the hip/waist area of the wearer.

[0019] In one embodiment of the invention, the invention could utilize detachable securing straps so that the garment portion of the swimwear could be removed from the securing straps and substituted with other garment portions of different texture, design, color etc. either as a whole or individually as to suit the wear's tastes.

[0020] The invention also provides for sun glyphs or suntan tattoos by having a simple design cut out of the garment so that ultraviolet tanning sunlight would be exposed to a portion of the wearer's body that would normally be covered by the swimwear. In this manner, when wearing other clothes that expose that portion of the wearer's body, the said sun tanned portion would form a tan glyph or tan tattoo.

[0021] The invention can also be applied to non-swimwear clothing such as a brassieres and brassiere-type clothing.

[0022] It is another object of the invention to provide an inexpensive, simple and easy means to individualize the wearer's clothing.

[0023] It is still another object of the invention to provide a means to obtain several differently designed swimwear at a lesser cost than buying several differently designed conventional swimwear.

DESCRIPTION OF THE DRAWINGS

- [0024] FIG. 1 A perspective drawing of the invention
- [0025] FIG. 2 A perspective drawing of the top piece
- [0026] FIG. 3 A perspective drawing of an alternative embodiment of the top piece
- [0027] FIG. 4 A perspective drawing of the bottom piece
- [0028] FIG. 5 A perspective drawing of an alternative embodiment of the bottom piece
- [0029] FIG. 6 A perspective drawing of the glyph
- [0030] FIG. 7 A perspective drawing of an alternative embodiment of the top piece
- [0031] FIG. 8 A perspective drawing of an alternative embodiment of the top piece
- [0032] FIG. 9 A perspective drawing of an alternative embodiment of the top piece
- [0033] FIG. 10 A perspective drawing of an alternative embodiment of the top piece

DESCRIPTION OF THE NUMERICAL LISTING

- [0034] 1 invention
- [0035] 10 bikini style swimwear
- [0036] 11 top piece
- [0037] 12 separate bust holder

- [0038] 13 right side bust holder
- [0039] 14 left side bust holder
- [0040] 15 attachment mechanism
- [0041] 16 securing mechanism
- [0042] 17 sliding clasp loop
- [0043] 18 clasp
- [0044] 20 securing apertures
- [0045] 21 attachment straps
- [0046] 22 attachment devices
- [0047] 23 attachment apertures
- [0048] 24 bust belt
- [0049] 30 bottom piece
- [0050] 31 covering
- [0051] 32 covering attachment mechanism
- [0052] 33 belt
- [0053] 34 connecting straps
- [0054] 40 glyph aperture
- [0055] 41 glyph
- [0056] 42 bandeau top

DETAILED DESCRIPTION OF THE PREFERRED EMBODIMENT

[0057] As shown in FIGS. 1 and 2, the invention generally denoted and referred to as numeral 1 can be applied to a single or multi-piece swimming suit or garment. The single piece swimming suit would have reversible detachable portions, while the multi-piece swimming suit would generally be of the bikini type of sun/swimwear. The bikini style swimwear generally denoted and referred to as numeral 10 would have a top or brassiere piece 11 and a bottom piece 30 which cover private portions of the wearer's chest and groin areas, respectively.

[0058] The top piece 11 of the bikini two-piece swimwear is composed of two separate panels that each covers at least a portion of at least one of the wearer's breasts. These particular panels or separate bust holders 12, one for the right side 13 and one for the left side 14. The common identities for this portion of the bikini-type swimwear goes under several different styles, including but not limited to guster underwire, bustier underwire halter, bra top underwire, seamed contour, pleated contour, triangle top, T-top, banded sports top, bandeau and then like. The separate bust holder 12 itself generally has a triangular shape.

[0059] Normally, the top piece 11 of the standard bikini-type swimwear is usually a unitary or one piece of apparel and does not feature separate bustholders 12 that are detachable from the top piece 11 itself. The invention 1, however, does provide for each separate bustholder 12 or panel to be reversibly detachable from the top piece 11. This allows the wearer to substitute, mix and match according to her own taste and fashion, various separate bustholders 12 or panels that feature at least two sides which differ in color, design, texture and the like. The separate bustholders 12 or panels can also be different in size and shape.

[0060] The invention 1 provides for the separate bustholders 12 or panels to be constructed with two sides that are designed to be worn comfortably against the skin of the wearer. The wearer selects which side of the separate bustholder 12 or panel is to be displayed as the front side, while the back side featuring different fashion from the front side (i.e., different design, color, and the like) is to be worn against/cover at least a portion the body of the wearer.

[0061] The invention 1 further provides that each separate bust holder 12 can be detachably connected to the top piece 11. This feature can be accomplished in great variety of ways that are well-known to the person who has ordinary skill in the art. In the preferred embodiment, the top piece 11 is comprised of two separate bust holders 12; an attachment mechanism, generally denoted by numeral 15; and a securing mechanism, generally denoted by numeral 16. The two separate bustholders 12 are connected directly to one another by the securing mechanism 15.

[0062] In the preferred embodiment, the attachment mechanism 15 and the securing mechanism 16 utilize a sliding clasp loop 17. The sliding clasp loop 17 which is hollow, accommodates a retractable spring-loaded clasp 18 which the wearer can recede into the interior of the sliding clasp loop 17 against the pressure of the spring. Without wearer intervention, the pressure of the spring forces the clasp 18 out of the interior of the hollow of the sliding clasp loop 17 so as to maintain the enclosed integrity of the sliding clasp loop 17 under operating conditions.

[0063] In the operation of the attachment mechanism 15, the wearer retracts the clasp 18 into the hollow interior of the sliding clasp loop 17 to create the passage through which the sliding clasp loop 17 may reversibly engage securing apertures 20 located along the edge of separate bustholders 12 and attachment straps 21. The wearer then releases the clasp 18 so that the enclosed integrity of the sliding clasp loop 17 is restored. In this manner, the securing mechanism 18 engages securing apertures on each separate bust holder 12 so as to locate the two separate bust holders 12 in correct proximity to one another while the top piece 11 is being worn on the chest of the wearer.

[0064] The securing mechanism 16 is used to attach and hold the top piece 11 on the upper torso of the user. In this manner, the securing mechanism 16 comprises of securing apertures 20, attachment straps 21 and attachment devices 22. The attachment device 22, which could be as varied in mechanism as the securing mechanism 15, is in the preferred embodiment, a sliding clasp loop 17. The sliding clasp loop 17 reversibly secures the attachment straps 21 to the sides of the separate bust holders 12 by reversibly engaging respective attachment apertures 20 located at the ends of the attachment straps 21 and on the side edges of the separate bust holders 12. The securing mechanism 16 can also feature different sides having different fashions from one another as well as from the various detachable panels of the invention 1.

[0065] Additionally, other embodiments of the invention 1, allows the separate bustholders 12 or panels to reversibly detach from each other and/or from the attachment straps 20 so that the separate bustholders 12 can be replaced with different bustholders 12 or be reversed/turned over and reattached to the top piece 11 for different orientation as to display and covering.

[0066] As shown in FIG. 3, other embodiments of the invention 1 which provided for reversibly detachable separate bust holders 12 include, but are not limited to, a top piece 11 which is constructed to have a belt-like structure, a bust belt 24, onto which the separate bustholders 12 can be reversibly attached. In this manner, the remaining structure of the top piece 11, sans the separate bust holders 12, can be made out of different colors, textures and designs and the like from the separate bust holders 12 themselves. The remaining structure and separate bust holders 12 can be reassembled and/or reversed for various different color, design, texture combinations so as to suit the wearer's taste at a particular time without the wearer having to purchase several different swimwear to achieve the desired result.

[0067] The wearer, in order to enhance their fashion choice of the swimwear, can merely reverse the placement of the top side or panel with the inside or panel of the separate bust holders 12 and remaining structure of the top piece 11 (e.g., the attachment mechanism 15 and securing mechanism 16) to obtain a top piece 11 with a different look. The wearer in this manner by reversing one or more sides of the various panels and pieces of the swimwear and/or reattaching swimwear panels from the left to the right side of the invention 1, can obtain a top piece 11 to suit the wearer's taste at that particular time, as well as alleviate the need of the wearer from buying a multitude of swimwear to obtain the desired variety of fashion.

[0068] FIG. 4 depicts the bottom piece 30 comprised of a panels or coverings 31 reversibly connected to the connecting straps 34 by a covering attachment mechanism 33. The covering 31 is generally a figure-8 shaped piece which the wearer fits its narrow portion through her legs so that the wider portions covers her groin area and at least a portion of her bottom. In a thong-style bottom piece 30, the covering 31 or be constructed according to style that allows a very generous portion of the wearer's bottom to be exposed or otherwise uncovered by the panel.

[0069] FIG. 5 depicts the opposing ends of the bottom piece 30 are generally attached to one another by connecting straps 34, or as shown in FIG. 5, are connected via hook and loop to a belt 33 that runs along the hip/waist area of the wearer. In either embodiment, the covering 31 is reversibly attached to the belt 33 or connecting straps 34 by a covering attachment mechanism 32. The covering attachment mechanism 32 can employ the same type of attaching mechanisms that are used for the attachment mechanism 15 and the securing mechanism 16. In the preferred embodiment of the bottom piece 30, a sliding clasp loop 17 is looped through attachment apertures 23 located on the ends and/or edges of the belt 33, connecting straps 34 and covering 31 to reversibly attach the covering 31 to the belt 33 and/or connecting straps 34.

[0070] As shown in FIG. 6, an additional embodiment of the invention would allow it to create a glyph 41 on the skin of the wearer by incorporating a specially-shaped glyph aperture 40 cut in the fabric of the invention 1 to allow ultraviolet radiation of the sunlight to penetrate to the skin of the wearer that would normally be covered up by the said fabric. This exposure to ultraviolet radiation would allow a normally untanned portion of the skin of the wearer to obtain a "tanning tattoo" in the shape of the glyph aperture 41. Thus the tanning tattoo or glyph 41 could then be seen by observers

when the wearer would be so covered (or uncovered) so as to allow the tanning tattoo or glyph **41** to be exposed in relation to the surrounding untanned skin of the wearer.

[0071] Another embodiment of the invention **1** can include a removable patch (utilizing hook and loop attachment means and the like) to cover the glyph **41** if the wearer does not desire such a tanning tattoo.

[0072] FIG. 7, 8 shows alternate embodiments of the invention **1** where the straps **21** are permanently connected at one end to the separate bust holder **12** or panels of the invention **1**, but still allow the detachment, inverting or changing out of the panels from one another. In the embodiments of the invention, the straps are the attachment **15** and securing mechanisms **16** both for the panels and the overall invention **1**.

[0073] The bottom piece **20** could also be alternatively constructed like the top piece **11** wherein all the reversibly attachable parts or panels of the bottom piece **20** are constructed with two sides that can be worn comfortably against the wearer's skin, with each side featuring a different color, design, texture, etc. from the various other sides. As with the top piece **11**, the wearer could arrange the bottom piece **30** with a single version of the invention **1** to provide the wearer with a multitude of choices of texture, color, design, etc. In this manner, the invention **1** could alleviate the need of the wearer from buying a multitude of swimwear to obtain the desired variety of fashion.

[0074] FIG. 10 depicts other embodiments of the invention that are non-swimwear articles of clothing which have the capacity to be constructed with detachable panels. Such articles of clothing include brassieres, bandeau tops **43** and the like.

[0075] In operation, the wearer, after selecting panels for the top piece **11**/bottom piece **30**, decides on which sides of the various panels for the bustholders **12**/covering **31** shall be the front side(s) and back side(s). If applicable, as for those embodiments featuring separate securing mechanisms **16**/connecting straps **34**/belt **35**, the wearer selects the securing mechanism **16** to which the panels will be attached. If a particular embodiment of the invention **1** features a securing mechanisms **16**/connecting straps **34**/belt **35**/etc. having sides of different fashion, the wearer then decides which sides of the securing mechanisms **16**/connecting straps **34**/belt **35**/etc. will be the front and back sides. The wearer, as applicable, then reversibly attaches the selected panels to the securing mechanisms **16**/connecting straps **34**/belt **35**/etc. in the desired orientation for display and coverage. The wearer can then later change the panels, securing mechanism or their side orientation to achieve a different look. The wearer could also combine sets of swimwear to form a combined group of panels having more panels than is necessary to complete one set of modular clothing.

[0076] Although these descriptions directly describe the above embodiments, it is understood that those skilled in the art may conceive modifications and/or variations to the specific embodiments shown and described herein. Any such modifications or variations that fall within the purview of this description are intended to be included therein as well. It is understood that the description herein is intended to be illustrative only and is not intended to be limitative.

I claim as my invention

1) modular clothing for use as swimwear which comprises:

1) at least one panel having at least a front side and a back side with one side of at least one panel being used to cover a private portion of the wearer;

2) the sides of at least one panel having different appearance from one another;

3) an attachment mechanism for attaching at least one panel to a securing mechanism; and

4) a securing mechanism reversibly secures at least one panel to the wearer.

2) The attachment mechanism reversible secures at least one panel to a securing mechanism.

3) Modular clothing of claim 1 wherein the panels differ in size or shape.

4) Modular clothing of claim 1 wherein the difference appearance of the sides of a panel is accomplished by one or more features of a group of features consisting of color, texture, design, indicia, and glyph.

5) Modular clothing of claim 2 wherein the front side of all the panels have the different appearances.

6) Modular clothing of claim 2 wherein all the back sides of the panels have an appearance that is different from one another and the front sides of the panels.

7) Modular clothing of claim 6 wherein the back sides have the same range of appearances as the front sides.

8) Modular clothing of claim 7 wherein the backsides have the same range appearances as the front sides, but no two panels are the same front side or back side.

9) Modular clothing of claim 1 wherein the modular clothing is bikini style swimwear.

10) Modular clothing of claim 1 wherein the modular clothing is brassiere type clothing.

11) Modular clothing of claim 1 wherein the attachment apparatus has at least two sides, a front side and a back side, both of which have a different appearances from the back sides and front sides of at least one panel.

12) A method of assembling modular clothing composed of multiple panels comprising of a front side and back side, the front side having a different appearance differing from the backside, the panels reversibly attached to a securing apparatus for reversibly securing the clothing to the wearer, comprising:

1) selecting panels to wear;

2) selecting the orientation of the sides of the panels for display and coverage when the modular clothing is worn; and

3) attaching the panels to selected attachment apparatus resulting in with the desired panel orientation for display and coverage when the clothing is worn.

13) A method of wearing modular clothing of claim 12 wherein the step of attaching the panels to the securing mechanism is reversible.

14) A method of wearing modular clothing of claim 12 wherein the sides of the attachment apparatus have different appearances from one and other.

15) A method of wearing modular clothing of claim 12 wherein the additional step is selecting panels from a group of panels obtained from two or more sets of swimwear.

16) A method of claim 12, wherein the step of selection of panels is made from a group of panels having more panels than is necessary to complete one set of modular clothing.

17) A method of wearing modular clothing of claim 12 wherein the additional step is the selection of an securing mechanism that features two sides, a front side and a backside which feature different designs from one another.

18) A method of wearing modular clothing of claim 12 wherein the additional step is the selection of an securing

mechanism that features two sides, a front side and a backside which feature different designs from one another.

19) A method of wearing modular clothing of claim 15 wherein the additional step is selecting of that side of the securing mechanism that is be placed against the body of the wearer.

20) A method of wearing modular clothing of claim 15 wherein the additional step is selecting of that side of the securing mechanism that is be displayed.

* * * * *