

*J.C. Dickey,*

*Well Tubing.*

*No. 109,880.*

*Patented Dec. 6. 1870.*

*Fig. 1.*

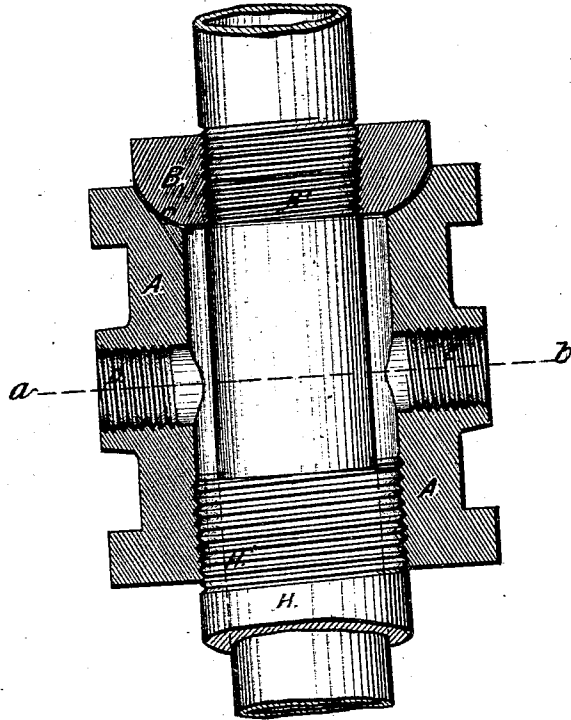

*Fig. 3.*

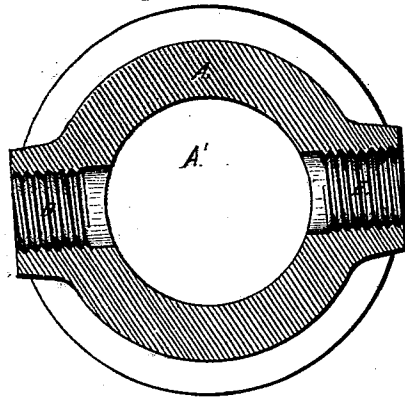
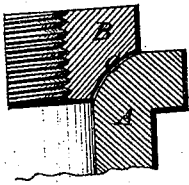

*Fig. 2.*

*Julius C. Dickey*

*Inventor.*

*A. B. Howland,* Witnesses:  
*J. H. Stevely*

# United States Patent Office.

JULIUS C. DICKEY, OF TITUSVILLE, PENNSYLVANIA.

Letters Patent No. 109,880, dated December 6, 1870.

## IMPROVEMENT IN CASING T'S FOR OIL-WELLS.

The Schedule referred to in these Letters Patent and making part of the same.

I, JULIUS C. DICKEY, of Titusville, in the county of Crawford and State of Pennsylvania, have invented certain Improvements in Casing T's for Oil-Wells, of which the following is a specification.

The object of this invention is to avoid the necessity of packing the joints between the T and the cap; and

It consists in such construction of the parts as will produce the effect desired, thereby lessening the cost of construction, making the connection more convenient, and air or gas-tight.

Figure 1 is a vertical section of the T and cap.

Figure 2 is a transverse section of the T on line *a b*.

Figure 3 is a broken section of the T and cap, showing the reverse construction of joints seen in fig. 1.

A is the T-connection, which may be made of any suitable metal, cast or wrought, and having the internal opening A'.

B is the cap, also made of any suitable metal, cast or wrought, and having aperture B', with a screw-thread cut therein.

Cap B is made to fit upon the upper edge of T, A, by forming it in a convex form where it comes in contact with the top edge of the T, which has a concave seat, C; or the seat C may be convex and the part that fits to it on the cap concave, as seen in fig. 3.

This construction of parts of the cap and T that come in contact with each other, when fitted to the same circle, will allow of the pipes connected to either the upper or lower side of the cap B to deviate from a perpendicular with relation to the T without opening the joint at C, between the cap and T, and the joint will remain air and gas-tight, although the pipes may not be exactly on an axial line through the T.

As the T's are usually constructed it is necessary

to pack the joint between the cap and T, which is very difficult to properly effect, as it will have to be done while the tubing is suspended in the well by means of the supporting cable, and is always attended with some risk and much inconvenience; and, in lowering the tubing into a well with the T's now in general use, the thimbles are liable, and do often, catch at every joint, thereby endangering the success of the operation, always requiring constant attention and watchfulness on the part of the attendants, all of which is obviated by constructing the parts of the cap and T, where they join and are in contact, on circular instead of straight lines.

Sometimes the T is constructed on its top end to have a circular recess, in which is inserted an iron or steel ring with its top edge either concave or convex to fit into the concave or onto the convex surface of the cap.

The tubing to be suspended in the well is screwed into the lower side of the cap B, and the tubing connecting with the tank is screwed into the top of the cap B.

The T A is screwed fast upon the casing H by the screw-thread H'.

The female-screws D and E receive gas-pipes to conduct gas to the fire-box of the engine, or for any other purpose desired.

Having thus described my invention,

What I claim, and desire to secure by Letters Patent, is—

The casing T for oil-wells, when the parts A and B are constructed and joined together in the manner and for the purpose described.

JULIUS C. DICKEY.

Witnesses:

M. C. BENEDICT,  
H. H. CURTISS.