

W. J. KAYSER.
CHIMNEY CAP AND VENTILATOR.

No. 441,101.

Patented Nov. 18, 1890.

Fig. 1.

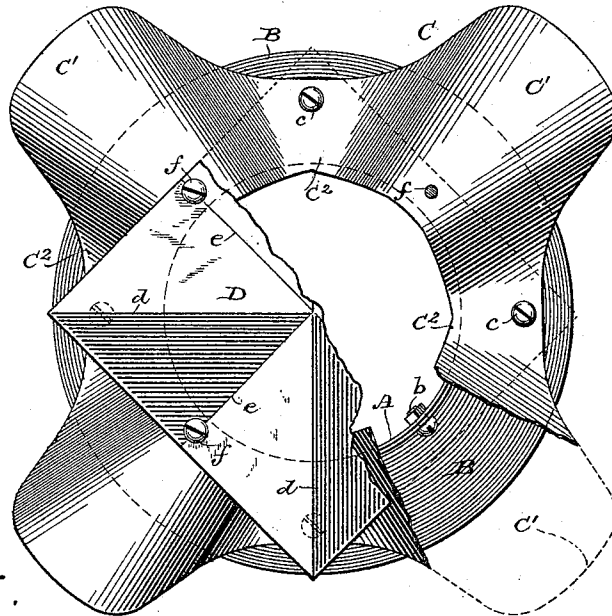

Fig. 5.

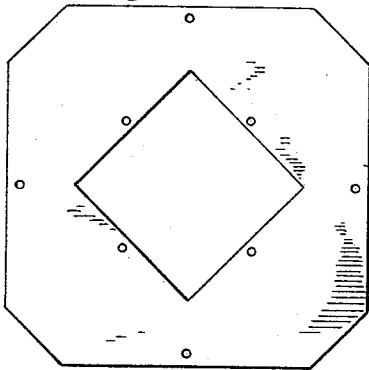

Fig. 6.

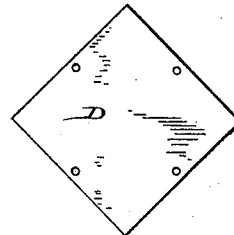
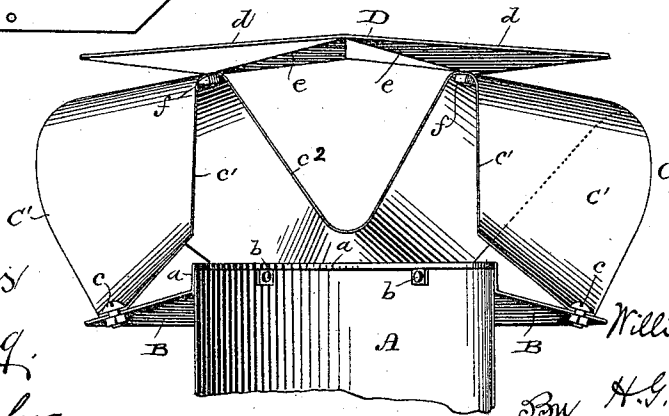

Fig. 2.



Witnesses
 Geo. W. Young,
 Wm. Kellog

Inventor
 William J. Kayser.
 By H. S. Underwood
 Attorney

W. J. KAYSER.
CHIMNEY CAP AND VENTILATOR.

No. 441,101.

Patented Nov. 18, 1890.

Fig. 3.

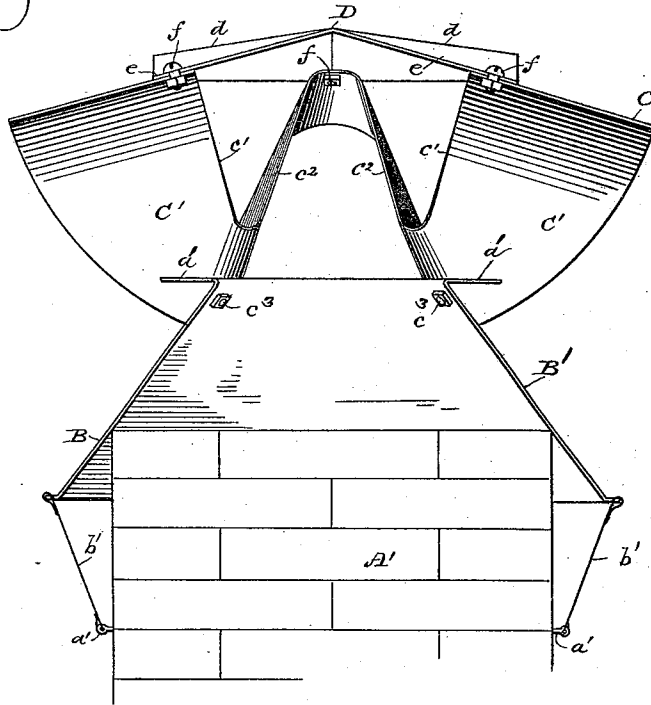
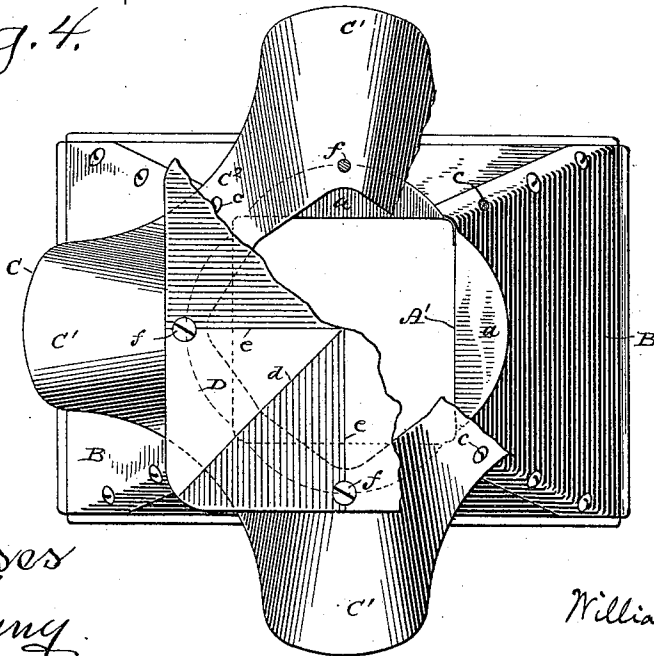

Fig. 4.



Witnesses
 Geo. W. Young
 Wm. Klug

Inventor
 William J. Kayser
 By H. G. Underwood
 Attorney

UNITED STATES PATENT OFFICE.

WILLIAM J. KAYSER, OF MILWAUKEE, WISCONSIN, ASSIGNOR TO THE WESTERN VENTILATING AND CHIMNEY CAP COMPANY, OF SAME PLACE.

CHIMNEY CAP AND VENTILATOR.

SPECIFICATION forming part of Letters Patent No. 441,101, dated November 18, 1890.

Application filed March 21, 1890. Serial No. 344,699. (No model.)

To all whom it may concern:

Be it known that I, WILLIAM J. KAYSER, of Milwaukee, in the county of Milwaukee, and in the State of Wisconsin, have invented certain new and useful Improvements in Chimney Caps and Ventilators; and I do hereby declare that the following is a full, clear, and exact description thereof.

My invention relates to chimney caps and cowls; and the invention consists in certain peculiar and novel features of construction and arrangement, as hereinafter described, and pointed out in the appended claim.

In the drawings, Figure 1 is a top or plan view, partly broken away, of a chimney-cowl and ventilator constructed in accordance with my invention. Fig. 2 is a central transverse vertical section of the same. Fig. 3 is a central transverse vertical section of a modified form of my device. Fig. 4 is a plan view, partly broken away, of the structure shown in Fig. 3. Figs. 5 and 6 are detached views of the blanks from which the ventilating band and cap are formed.

The objects of my invention are to produce a ventilator and cowl of the simplest and most durable form, which shall completely prevent downdrafts in the chimney under all varying atmospheric conditions, and which shall effectually protect the chimney from effects of the weather, and, furthermore, to materially economize stock in the manufacture of the ventilator, so that the device shall be very inexpensive and all waste of stock be practically avoided. These results I attain by virtue of the construction which I will now proceed to describe.

Referring first to the construction shown in Figs. 1 and 2, A designates a section of pipe which is designed to be secured to the top of a chimney in any suitable or preferred manner. B designates a circular wind-guard, which is formed at its inner edge with a vertical flange *a*, which surrounds the upper end of pipe A and is secured thereto by any required number of bolts *b* and the usual nuts therefor. This wind-guard extends outwardly and downwardly from the flange *a*, and thus its upper surface deflects the wind

upward from the flue of the chimney. Upon this guard rests the ventilator C, which consists, preferably, of a continuous piece of sheet metal bent into alternately U-shaped portions *c*² and inverted-U-shaped portions C', the closed tops of the inverted-U-shaped portions extending upwardly and inwardly and their outer edges projecting beyond the outer edges of the U-shaped portions *c*². The bends of said portions *c*² rest upon the wind-guard B, and the ventilator is secured thereto by bolts and nuts *c*. D designates the cap, which is formed with alternate radial ridges *d* and valleys *e*, and the cap is secured to the inner edges of the tops of the inverted-U-shaped portions of the ventilator.

The construction shown in Figs. 3 and 4 differs from that above described only in the form of the wind-guard D, which is of such shape as to adapt the device for attachment directly to a square chimney A'. In this instance the wind-guard B' is of truncated pyramidal form and extends obliquely above and below the top of the chimney. Its lower edge is attached to the chimney by stout wires *b*, the lower ends of which are attached to eyebolts or screws *a'*, projecting from the sides of the chimney near its top. The flange *a*² of the wind-guard in this instance projects horizontally outward from the inner edge of the guard, and the bottoms of the inverted-U-shaped portions *c*² of the ventilator are secured to the upper part of the guard by bolts and nuts *c*³.

It will thus be seen that in either form of the device the utmost simplicity of construction is attained, the structure consisting, essentially, of but three parts—viz., the wind-guard or deflector, the ventilator, and the cap—and each of these parts is of very simple form. Gusts of wind striking the guard are deflected upward and are carried out between the inverted portions C' and the cap or through said portions or through the U-shaped portions *c*². The cap D prevents the entrance of rain into the chimney, and such moisture runs off by the gutters or valleys of the cap.

By reference to Figs. 5 and 6 it will be seen

that the ventilator and cap are formed originally from a single blank of sheet metal, the cap-blank being cut out of the center of the ventilator-blank, and such parts being subsequently bent to the forms above described. Thus the utmost economy of material is attained, and all waste is practically avoided.

It is to be observed that the bends of the U-shaped and inverted-U-shaped ventilator-sections are of segmental form without any acute angles and that the inverted bends extend nearly horizontal, thus spreading well out over the chimney-top and effectually excluding moisture, while in no way obstructing the draft in the chimney; furthermore, that these upper bends afford convenient and durable supports for the cap-piece and at the same time are so disposed as to permit free exit of smoke and gases from the chimney. In addition, the outside currents of air, which strike on the upper surface of the circular wind-guard, pass upward over the flange thereof inside the device and out through any of the openings of the continuous ventilator-band, while the outside air-currents which strike against the upper surface of the U-shaped portions c^2 of said ventilator-band pass into the device through the openings at the inner edge of said portions c^2 of the band beneath the projecting points of the cap D, and are thereby compressed by a funnel-like action, and hence enter the interior of the device with great power, and in their rapid passage across the interior of the device and out through the openings thereof these compressed air-cur-

rents create great suction, forcing with them all the smoke and gases from the chimney, the currents which enter any one of these funnel-openings of the portions c^2 having instant and free escape through all the openings in the band, and hence spread outward in all directions, thereby greatly augmenting the said suction.

Having thus described my invention, what I claim as new therein, and desire to secure by Letters Patent, is—

An improved chimney cap and ventilator comprising a continuous wind-guard secured to a chimney top or pipe and extending outwardly and downwardly, a ventilator-band attached to the upper end of the wind-guard by U-shaped bends and having inverted-U-shaped portions continuous with and alternating with the U-shaped bends and extending in slightly downwardly and outwardly inclined position, and a cap-piece cut from the body of the ventilator and having radial alternating ridges and valleys and also secured to the upper side of the bends of the inverted-U-shaped sections of the ventilator-band, substantially as set forth.

In testimony that I claim the foregoing I have hereunto set my hand, at Milwaukee, in the county of Milwaukee and State of Wisconsin, in the presence of two witnesses.

WILLIAM J. KAYSER.

Witnesses:

H. G. UNDERWOOD,
WM. KLUG.