

G. S. SMALLWOOD.
CAB.

No. 497,352.

Patented May 16, 1893.

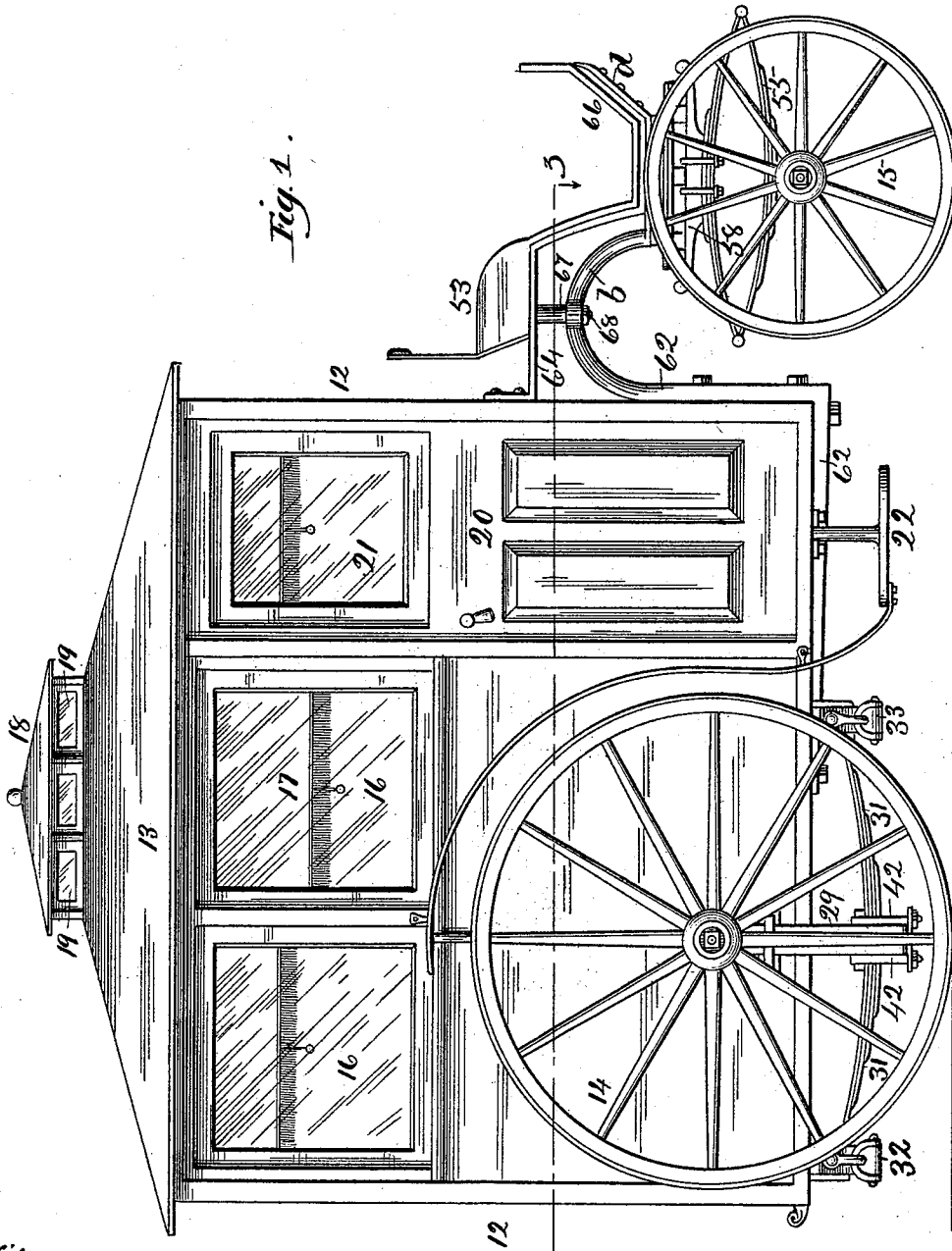

Fig. 1.

Witnesses:

J. P. Donaldson,
L. M. Freeman

Inventor:

G. S. Smallwood,
By L. B. Coupland & Co
attys

(No Model.)

5 Sheets—Sheet 2.

G. S. SMALLWOOD.
CAB.

No. 497,352.

Patented May 16, 1893.

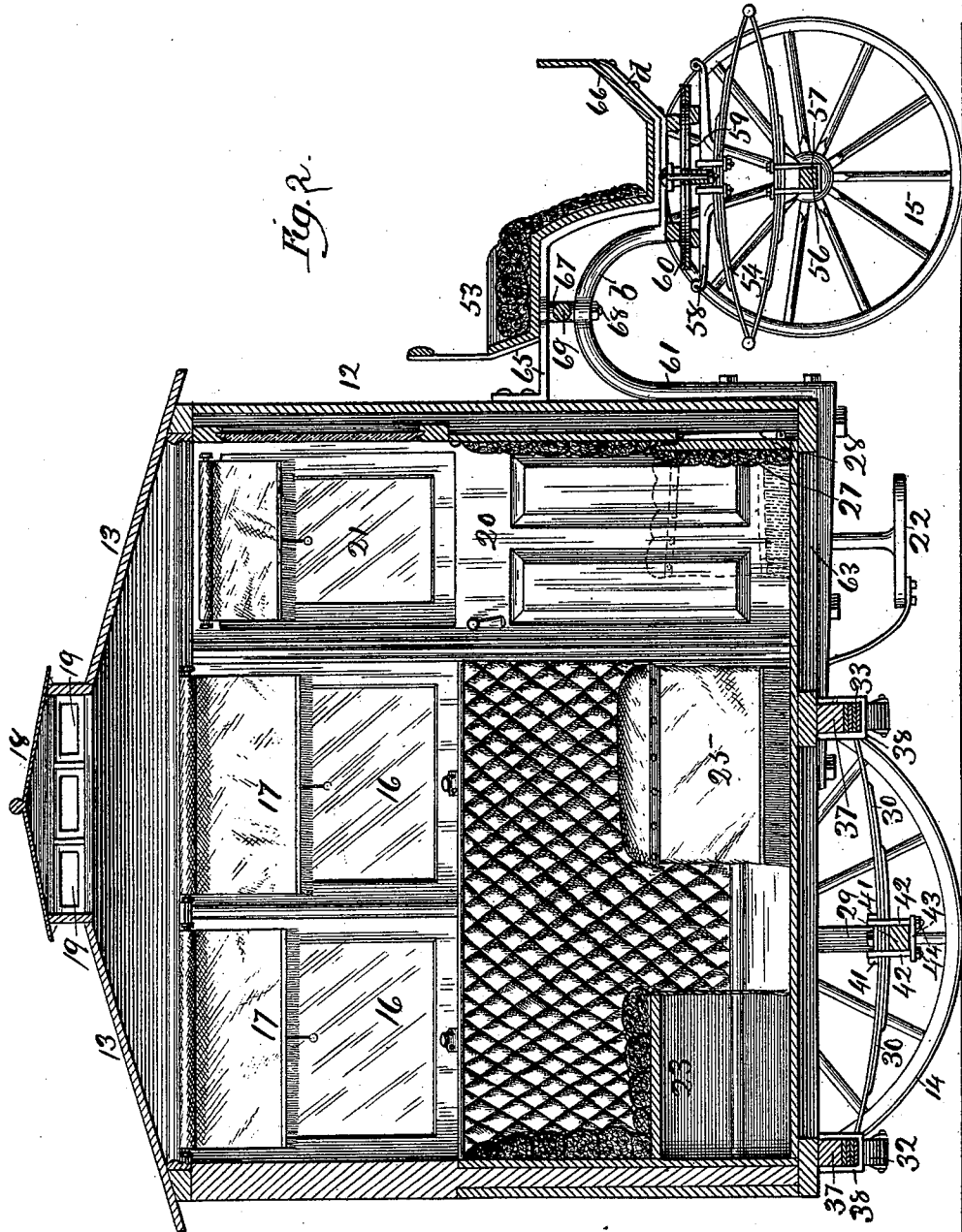

Witnesses:

J. B. Donaldson
L. M. Freeman.

Inventor.

G. S. Smallwood.
By G. B. Coupland & Co.

Attorneys.

G. S. SMALLWOOD.
CAB.

No. 497,352.

Patented May 16, 1893.

Fig. 3.

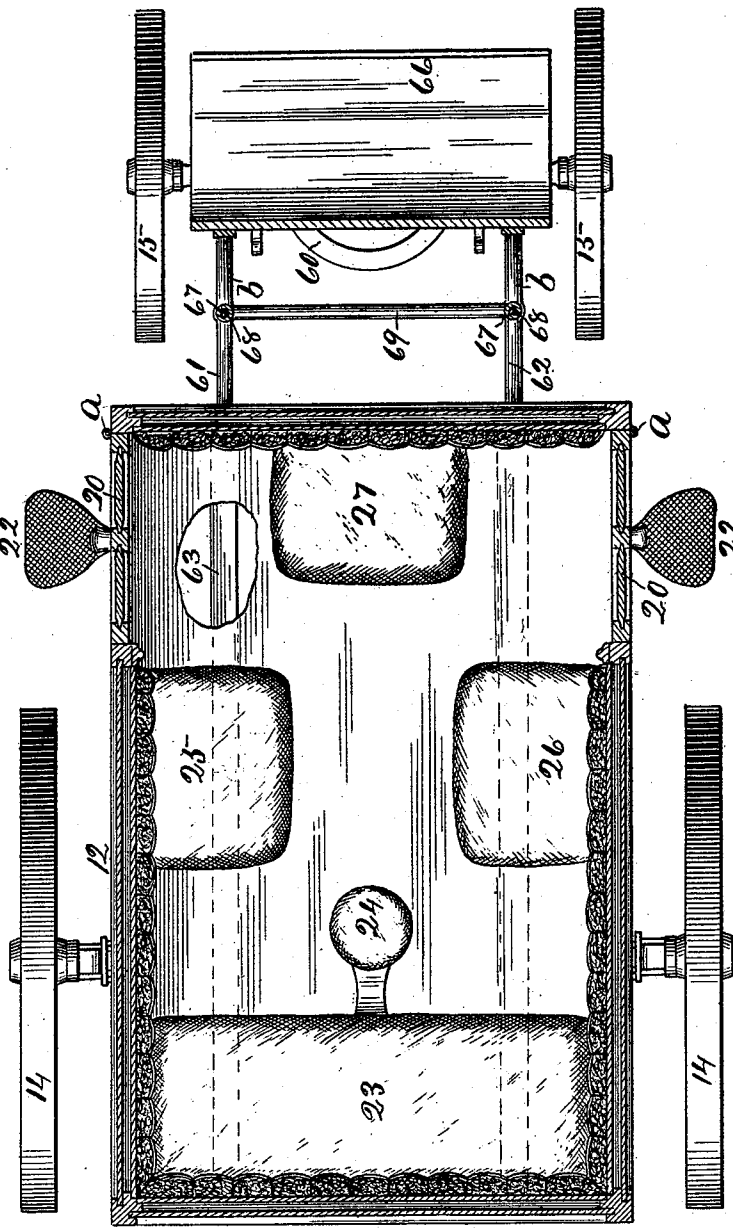

Witnesses

J. B. Donaldson.
L. M. Freeman.

Inventor:

G. S. Smallwood.
By G. B. Coupland & Co
Attorneys.

G. S. SMALLWOOD.
CAB.

No. 497,352.

Patented May 16, 1893.

Fig. 4.

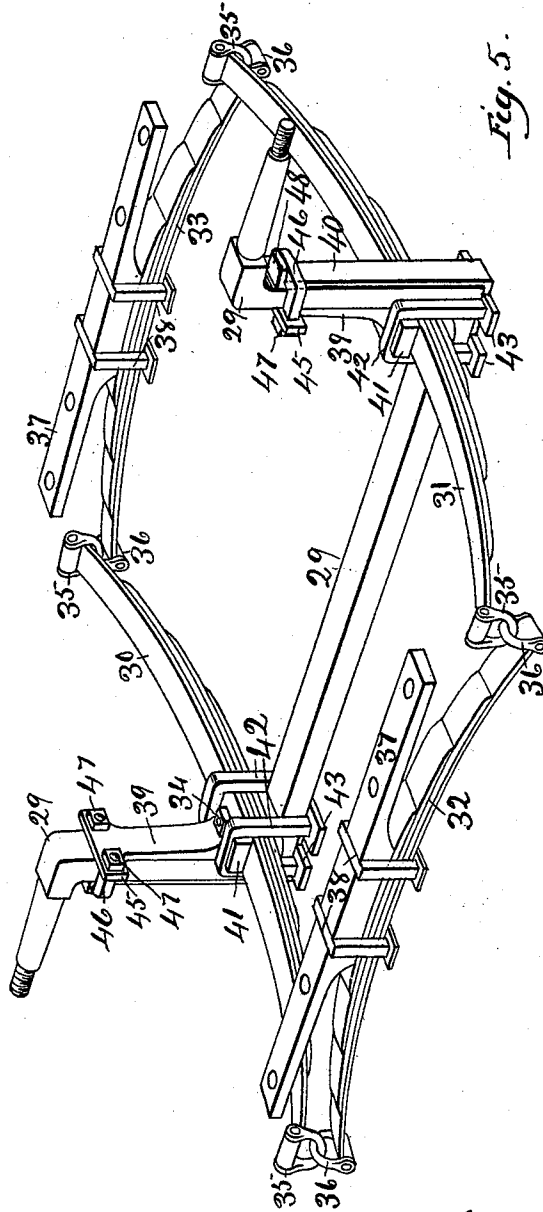
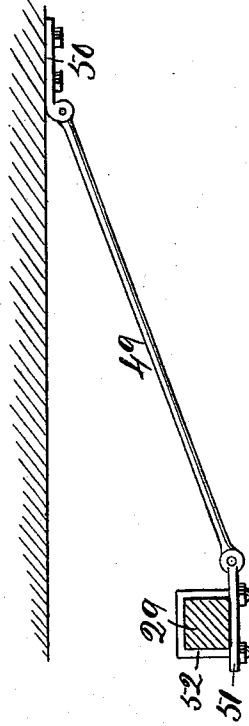

Fig. 5.



Witnesses:

J. P. Donaldson.
L. M. Freeman.

Inventor:

G. S. Smallwood.
By G. B. Coupland & Co.
Attorneys.

G. S. SMALLWOOD.
CAB.

No. 497,352.

Patented May 16, 1893.

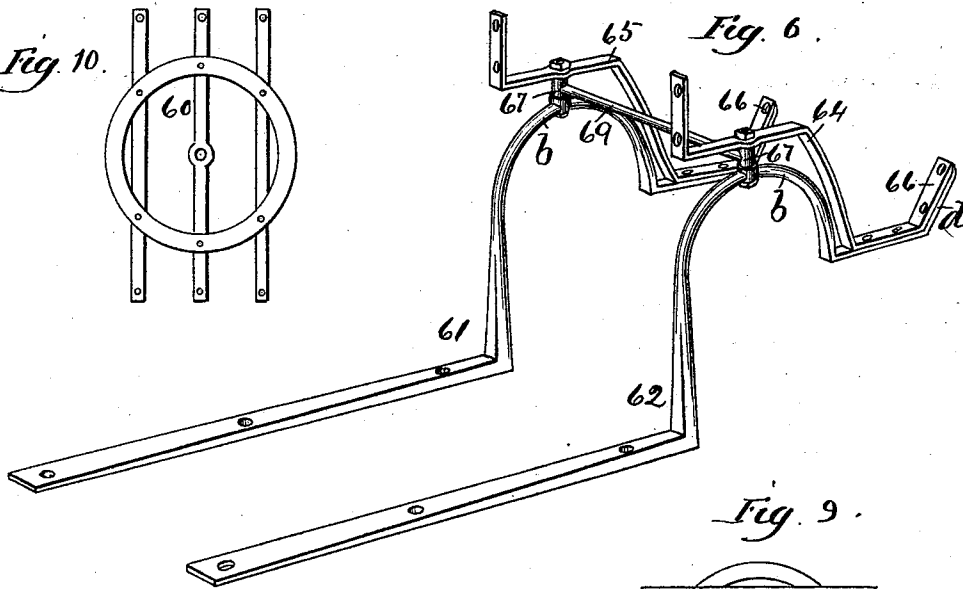
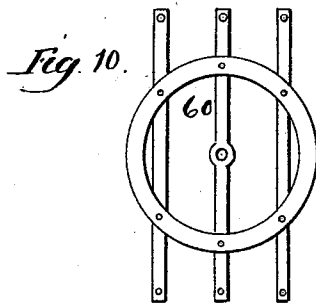
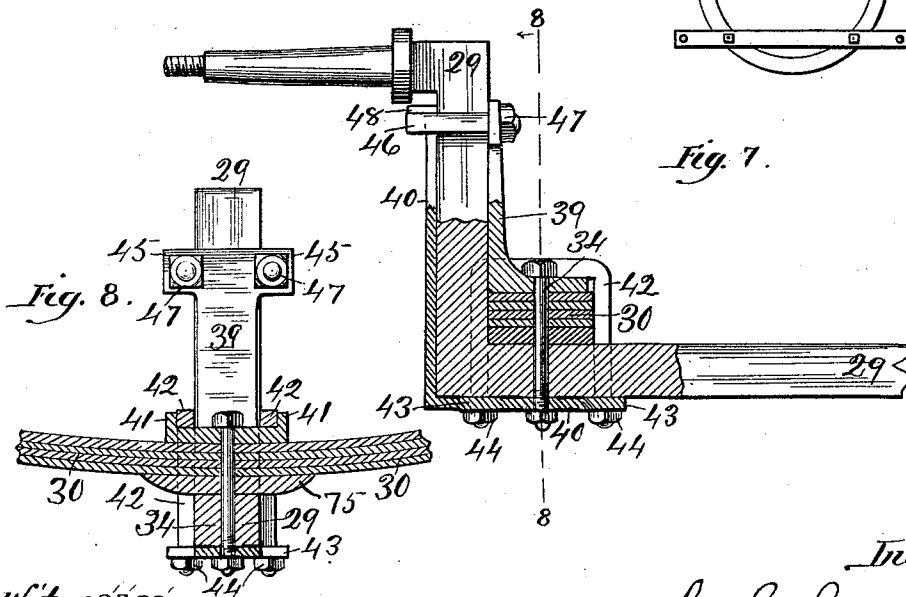
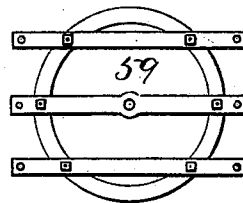

Fig. 9.



Witnesses:
J. B. Donaldson.
L. M. Freeman

Inventor:
G. S. Smallwood.
By G. B. Boydland & Co.
Attorneys.

UNITED STATES PATENT OFFICE.

GEORGE S. SMALLWOOD, OF CHICAGO, ILLINOIS, ASSIGNOR TO LEMUEL B. COUPLAND, OF SAME PLACE.

CAB.

SPECIFICATION forming part of Letters Patent No. 497,352, dated May 16, 1893.

Application filed February 12, 1892. Serial No. 421,280. (No model.)

To all whom it may concern:

Be it known that I, GEORGE S. SMALLWOOD, a citizen of the United States, residing at Chicago, in the county of Cook and State of Illinois, have invented certain new and useful Improvements in Cabs, of which the following is a full, clear, and exact description, that will enable others to make and use the same, reference being had to the accompanying drawings, forming a part of this specification, in which—

Figure 1 is a side elevation of a cab structure embodying my improved features; Fig. 2, a vertical longitudinal section; Fig. 3, a horizontal section on line 3, Fig. 1, looking in the direction indicated by the arrow; Fig. 4, a perspective of the spring platform gear on which the body of the vehicle is mounted; Fig. 5, a broken-away sectional detail; Fig. 6 a perspective of the iron work supporting the driver's seat; Fig. 7, a broken-away elevation and part section of the axle; Fig. 8, a broken-away vertical section on line 8 Fig. 7, looking in the direction indicated by the arrow; and Figs. 9 and 10 detached details of the gear-platform on which the front wheels turn.

This invention relates to improvements in that class of vehicles known as cabs of the four-wheel type, and has for its object to provide a structure of this character that will increase the carrying capacity without exceeding ordinary dimensions and that will afford convenient ingress and egress; the general structural features and arrangement of the different parts, combining safety, strength, durability and convenience, as will be hereinafter set forth.

In the drawings, 12 is the cab-body, 13 the roof or top, 14 the two hind or main carrying-wheels, and 15 the two smaller front wheels.

The paneling of the sides and ends of the vehicle-body is all straight work, presenting no convex or concave surfaces. The upper part is provided with windows, 16, on both sides, the ends of which may be lowered inside of the paneling or locked in a closed position as required. The windows are provided with curtains, 17.

The hip-roof terminates in the monitor top,

18, having straight vertical inclosing sides 50 and an overhanging hip roof, the sides having openings therein protected by small windows 19, which may be opened to afford ventilation. This monitor top also provides space for a lamp to be suspended on the inside. 55 The roof overhangs and protects the sides from the drip. This form or style of roof in a cab presents a unique appearance.

The two doors, 20, are located on each side near the front end, are hinged as at *a*, and 60 open toward the front. The front wheels are set closer together than the main wheels and track inside of the same, so that the doors may open clear back parallel with the sides of the body, affording convenient ingress and 65 egress, and are also out of the way of any passing vehicles when in an open position. The upper parts of the doors are provided with curtained windows 21.

22 are steps, properly supported from the 70 bottom of the structure. The front wheels are of a less diameter than the hind wheels.

The arrangement of the seats is clearly shown in Fig. 3. The double back seat, 23, is stationary and extends from side to side. 75 Connected with this double seat is a temporary seat, 24, for the accommodation of a child. This seat is adapted to fold underneath the permanent seat out of the way when not required for use. The two side seats, 25 and 26, 80 and the front seat, 27, are hinged at their back edges to the lining of the body and have legs, 28, hinged to the front edges to support the same in a seating position, and fold underneath and thus permit of these seats being 85 dropped down parallel, as shown in Fig. 2, with the inclosing sides and out of the way when there are but one or two passengers, thus affording ample room for baggage and parcels. This arrangement provides seating 90 capacity for six persons and leaves passageway for ingress and egress when all the seats are in position for use. The body will ordinarily be of the rectangular form in horizontal section, shown which together with the 95 arrangement of the seats and doors will afford the greatest carrying capacity within certain limited dimensions. The main axle,

29, is of the bent type, and permits the lower part of the body to set down well below the center of axis, bringing the steps within convenient reach and doing away with the liability of the vehicle overturning.

The supporting-platform-gear consists of the two parallel side springs, 30 and 31, and the companion transverse springs, 32 and 33. These springs are arranged in the form of a square and are loosely connected at their respective ends and corners. The side springs are placed with the concave sides upward, and rest on the pillow blocks 75, which in turn rest upon the axle-bar, near their longitudinal centers and are secured thereto by bolts 34. The transverse springs have the convex side upward; the ends extending under the corresponding ends of the side springs and being loosely suspended therefrom, as shown in Fig.

4. To the respective ends of each of the side springs are pivoted the curved links or loops, 35, hanging downwardly, and which interlock with companion links, 36, projecting upwardly and pivoted to the ends of the transverse springs, forming a swivel or universal joint-connection, so that the springs yield in any direction, and automatically adjust themselves to any requirement. The companion transverse spring-bars, 37, are seated on the transverse springs and are secured thereto by clips, 38. These bars are perforated to receive the bolts securing the cab-body. The springs composing the platform are all of the semi or half elliptic form.

The form of axle shown is liable to bend or break across the corners. It is, therefore, necessary to strengthen the same at those points. This is done by means of an inside corner or angle-iron, 39, and an outside angle-iron, 40, shown in Figs. 4, 7 and 8. The lower end of the inside corner iron or irons is provided, at each side, with the upturned lip, 41, to lock the head-end of the fastening-clips, 42, in place. The lower ends of clips 42 are connected underneath the axle by clip-bars, 43, formed on the lower end of the outside angle-iron and secured in place by nuts 44. Clips 42 also embrace the side springs and assist in retaining the same in proper position.

The upper bar-end, 45, of the inside corner iron is perforated for the insertion of the threaded ends of clip 46 locked in place by nuts 47. This clip embraces the upper end of the outside corner iron which is provided with the overturned lip, 48, (Fig. 7,) thus firmly securing the upper ends of the corner irons with reference to the axle. By this arrangement the axle-bar is greatly strengthened at the weak points and the side-springs firmly fastened at their longitudinal centers. One end of the steadying or stiffening brace-rod, 49, (Fig. 5,) is pivoted to plate 50, bolted to the under side of the body. The opposite end is pivoted to plate 51 bearing against the under side of the axle, and secured by clip 52 embracing the axle. There will be two or

more of these brace-rods used in the construction, located both forward of and back of the axle.

The driver's seat, 53, is located in front of the cab-body over the front wheels, and the means employed in supporting the same and the fifth wheel gear-attachment will next be described. The two elliptic springs, 54 and 55, are located just inside of the respective front wheels; the under half being secured to axle 56 by clips 57; and the upper half to spring-bars, 58, on which rests the lower half, 59, (Fig. 9,) of the fifth-wheel gear. The upper half, 60, of this gear (Fig. 10,) is secured to the under side of the front part of the main supporting-irons, 61 and 62. These irons are of the shape shown in Fig. 6, the back horizontal ends running under the cab-body and being bolted to the two inside sills, 63, occupying the relative position to the outside sills of the floor as that shown by the broken-away part in Fig. 3. These irons turn upwardly at right angles for some way, and are bolted to the lower front part of the body, then curve to the front downwardly and form the arched part or goose-neck *b*, then extend horizontally across the fifth wheel-gear and terminate in the upwardly inclined ends *d*. This forms a very strong connection and support between the cab-body and the front wheel-gear platform and the driver's seat. The arched parts of the irons provide room for the front wheels to turn in under and thus permit of the vehicle being turned within limited space. The upturned rear ends of seat-irons, 64 and 65, are bolted to the cab-body and from thence extend forward and down and are bolted to the horizontal and terminal parts of irons 61 and 62, forming a support for the foot-rest 66. The lower ends of tubular posts, 67, are mounted on the arched part of irons 61 and 62; the seat-irons resting on the upper ends of these posts, and the parts secured by bolts 68. The posts are connected by a strengthening cross-bar 69. By having the front wheels track inside of the hind wheels, ample room is provided for door-space, and the loose earth picked up by the wheels is not thrown back on the fenders of the hind wheels, so that ingress and egress may be effected without damage to the clothing.

Having thus described my invention, what I claim as new, and desire to secure by Letters Patent, is—

1. A cab or vehicle body of a rectangular form in horizontal section, having straight vertical inclosing sides, and provided with an overhanging hip-roof terminating in a monitor top also having an overhanging hip roof and straight vertical inclosing sides in which are ventilator openings, substantially as set forth.

2. A cab or vehicle body having straight side walls, swinging doors hinged to the respective sides of the body at the front corners, hind wheels tracking outside the body, and front wheels of less diameter than the hind

wheels and tracking inside the width of the cab body, whereby said doors may be swung open parallel to the inclosing sides without interfering with the front wheels, substantially as set forth.

3. In a cab or vehicle, the combination of the bent axle bar, the side springs, the inside angle corner irons, and clips connecting the parts together in such manner that the side springs are inclosed between the axle bar and the angle irons, substantially as set forth.

4. The combination of the bent-axle, the side-springs, the inside corner iron, the outside corner iron and the clips, securing said irons to the horizontal and vertical parts of the axle, substantially as set forth.

5. The combination of the bent axle bar, the pillow blocks, the side springs resting on said blocks, the corner irons overlying the springs, the clips for securing the vertical flanges of the irons to the upright parts of the axle bar, and the clips for clamping the springs between the horizontal flanges of the irons and the axle and pillow blocks, substantially as described.

6. The combination of the bent axle bar, the pillow blocks, the side springs resting on said blocks, the inside corner angle-irons overlying the springs, the outside corner angle-irons,

the clips for securing the vertical flanges of the inside and outside irons to the upright parts of the axle bar, and the clips for clamping the springs between the horizontal flanges of the inside irons, and the axle and pillow blocks, substantially as described.

7. In a cab, or vehicle of the class described, the combination of the arched companion irons, the companion seat irons, secured at their rear ends to the cab-body and at their forward ends to the corresponding part of the arched irons, the posts, supporting the seat-irons, the bolts, rigidly securing these parts, and the transverse bar connecting said posts, substantially as set forth.

8. The combination with the vehicle body and the gear platform over the front wheels, of the arched companion irons, the companion seat irons, secured at their rear ends to the cab body and at their forward ends to the corresponding parts of the arched irons, the posts supporting the seat irons, the bolts rigidly securing these parts, and the transverse bar connecting said posts, substantially as described.

GEORGE S. SMALLWOOD.

Witnesses:

L. M. FREEMAN,
L. B. COUPLAND.