

(19) **DANMARK**

(10) **DK/EP 3748098 T3**



Patent- og  
Varemærkestyrelsen

(12) **Oversættelse af  
europæisk patentskrift**

- 
- (51) Int.Cl.: **E 04 B 9/36 (2006.01)** **E 04 B 9/26 (2006.01)** **E 04 B 9/28 (2006.01)**
- (45) Oversættelsen bekendtgjort den: **2025-06-10**
- (80) Dato for Den Europæiske Patentmyndigheds bekendtgørelse om meddelelse af patentet: **2025-05-07**
- (86) Europæisk ansøgning nr.: **20178010.3**
- (86) Europæisk indleveringsdag: **2020-06-03**
- (87) Den europæiske ansøgnings publiceringsdag: **2020-12-09**
- (30) Prioritet: **2019-06-05 GB 201908014**
- (84) Designerede stater: **AL AT BE BG CH CY CZ DE DK EE ES FI FR GB GR HR HU IE IS IT LI LT LU LV MC MK MT NL NO PL PT RO RS SE SI SK SM TR**
- (73) Patenthaver: **Hunter Douglas Industries B.V., Blaak 555, 3011 GB Rotterdam, Holland**
- (72) Opfinder: **VAN KOPPEN, Jaap, c/o Hunter Douglas Industries B.V., Piekstraat 2, PO Box 5072, 3008 AB Rotterdam, Holland**
- (74) Fuldmægtig i Danmark: **Zacco Denmark A/S, Arne Jacobsens Allé 15, 2300 København S, Danmark**
- (54) Benævnelse: **Loftssystem**
- (56) Fremdragne publikationer:  
**EP-A1- 3 399 118**  
**FR-A1- 2 528 889**  
**US-A- 4 735 030**



# DESCRIPTION

## Description

**[0001]** The following relates to a a ceiling system, in particular a system for supporting a suspended ceiling.

**[0002]** Surface covering systems, such as ceiling systems are known, in which ceiling panels are supported by carriers to provide a surface that covers an underlying architectural structure such as a roof structure. The ceiling panels may be decorative, for example providing a false ceiling to conceal a space in which building services may be provided, and/or may be baffles, which may occasionally be used to dampen sound in the space below the ceiling system. US 4,735,030, FR 2 528 889 and EP 3 399 118 disclose various arrangements of surface covering systems. In particular, US 4,735,030 discloses a generally U-shaped clip, which rests on a carrier, with a ceiling panel hanging from the clip.

**[0003]** It is desirable for such surface covering systems to be designed with consideration for the ease of installation and/or the ease of performing subsequent processes on the system, such as maintenance and/or cleaning.

**[0004]** As described herewith, there is provided a ceiling system as defined in appended claim 1, and a method of assembling such a ceiling system as defined in appended claim 13.

**[0005]** Embodiments will be more clearly understood from the following description, given by way of example only, with reference to the accompanying drawings in which:

Figure 1 illustrates a ceiling system;

Figure 2 illustrates a part of the ceiling system shown in Figure 1;

Figure 3 illustrates, in cross-section the part of the ceiling system shown in Figure 2; and

Figure 4 depicts a clip for use in the ceiling system shown in Figure 1.

**[0006]** Figure 1 illustrates an example of a ceiling system 10. The ceiling system is configured to support one or more ceiling panels 11.

**[0007]** The ceiling panels 11 shown in this arrangement have a lower face that primarily forms the surface visible to occupants of the space below, namely that covers the structure to which it is mounted. However, as pictured in Figure 1, there may be spaces between the ceiling panels 11 through which occupants may be able to see some of the structure supporting the ceiling

panels 11 and/or the structure from which the ceiling system 10 may be suspended.

**[0008]** The ceiling panels 11 are supported by a plurality of carriers 12. At least one ceiling panel 11 may be supported by at least one carrier 12. In arrangements, the ceiling system 10 may include a plurality of ceiling panels 11 and each ceiling panel 11 may be supported by a plurality of carriers 12. In general, a ceiling system 10 may be formed from any number of ceiling panels 11, supported by any number of carriers 12. Each ceiling panel 11 may be supported by any number of carriers 12 and each carrier 12 may support any number of ceiling panels 11.

**[0009]** Use of the carriers 12 to support the ceiling panels 11 rather than supporting each ceiling panel 11 independently may reduce a number of connections to be made to a structure from which the ceiling system 10 is suspended. Additionally, the carrier 12 may also fix the position of adjacent ceiling panels 11 relative to each other. This may facilitate the installation of the ceiling system and/or facilitate the provision of a high quality finished appearance. In an arrangement, the carrier 12 may first be mounted to the structure from which the ceiling system is suspended. The carrier 12 may be directly mounted to the structure and/or by way of at least one other component, such as suspension wires. The ceiling panels 11 may be introduced to the carrier 12 from below, namely from the side of the ceiling surface provided by the ceiling system, to be supported by the carrier 12. In an arrangement, it is not necessary to provide a connector to connect the ceiling panels 11 to the carrier 12. It may be sufficient for the ceiling panels 11 to engage with a part of the carrier 12 and be held in place by the weight of the ceiling panel 11.

**[0010]** According to the present disclosure, the ceiling system 10 further includes a clip 20 that is provided to assist in maintaining the engagement of a ceiling panel 11 with a carrier 12. This may reduce the possibility of a ceiling panel 11 becoming detached from a carrier 12 in the event of an accidental contact with a ceiling panel 11, for example during installation, maintenance and/or cleaning. In the absence of the clip 20, there may be an elevated risk of such an accidental detachment of the ceiling panel 11 for arrangements in which the ceiling panel 11 is introduced to the carrier 12 from below for engagement.

**[0011]** In an arrangement, the clip 20 comprises a length of wire that includes at least one engagement section 21, 22 that engages with either the ceiling panel 11 or the carrier 12 and secures the position of the engagement section 21, 22 relative to the ceiling panel 11 or carrier 12 to which it is engaged. The clip 20 further includes a pressing section 30 that presses together the engaged parts of the ceiling panel 11 and the carrier 12. In the arrangement depicted in Figures 2 and 3, the engagement section 21, 22 engages with the carrier 12 to secure its position relative to the carrier 12 and the pressing section 30 presses against the ceiling panel, as discussed further below, in order to press together the engaged parts of the ceiling panel 11 and the carrier 12. It should be appreciated, however, that this arrangement may be reversed.

**[0012]** In an arrangement, a clip 20 may be provided at each point at which a ceiling panel 11

is engaged with, and supported by, a carrier 12. However, this is not essential. For example, if a ceiling panel 11 is supported by plural carriers 12, sufficient benefit may be provided if a clip 20 is provided at the interface between the ceiling panel 11 and only some of the carriers 12 that support it. It may be sufficient for a clip 20 to be provided at only one interface between the ceiling panel 11 and one of the carriers 12 supporting it.

**[0013]** It should also be appreciated that, in some arrangements, one or more of the ceiling panels 11 may not have any clips 20 provided at the interfaces with the carriers 12 supporting it. For example, the clips 20 may only be provided to ceiling panels 11 that are considered to be at risk of accidental contact, for example those in the region of other fittings that may require maintenance, such as light fittings.

**[0014]** According to the invention, the ceiling system 10 is configured such that, when the ceiling panel 11 is supported by the carrier 12, part of the carrier 12 exerts an upwards force on part of the ceiling panel 11 to support it. In such an arrangement, the ceiling panel 11 may be held in place relative to the carrier 12 by its own weight.

**[0015]** The clip 20 is arranged such that the pressing section 30 exerts a downwards force on the ceiling panel 11 to press together the engaged parts of ceiling panel 11 and the carrier. In such an arrangement, the pressing section 30 of the clip 20 works in conjunction with the weight of the ceiling panel 11 to hold the ceiling panel 11 in engagement with the carrier 12. In such an arrangement, an accidental contact with the ceiling panel 11 may not be sufficient to disengage the ceiling panel 11 from the carrier 12 even if the force of the contact would have been enough to act only against the weight of the ceiling panel 11. However, it should also be appreciated that, in such an arrangement, the clip 20 need not be arranged to provide a sufficient force to support the weight of the ceiling panel because the weight of the ceiling panel 11 is supported directly by the carrier 12.

**[0016]** As shown in Figure 2, the ceiling system 10 may be arranged such that the support of the ceiling panel 11 by the carrier 12 is based on one or more protrusions 41 of the carrier 12 engaging with corresponding recesses 42 of the ceiling panel 11.

**[0017]** In such an arrangement, for a ceiling panel 11 to be disengaged from the carrier 12, requires sufficient movement of the ceiling panel 11 relative of carrier 12 is required that the protrusions 41 completely disengage from the recesses 42 of the ceiling panel. Accordingly, in the event of accidental contact with the ceiling panel 11, it may not disengaged from the carrier 12 if it only results in a small movement. In such an arrangement, the pressing section 30 of the clip 20 may be configured to apply force in a direction that encourages the protrusions 41 of the carrier 12 to remain within the recesses 42 of the ceiling panel 11. It should be appreciated that the arrangement of protrusions and recesses may be reversed, such that a protrusion on the ceiling panel 11 engages with a recess on the carrier 12.

**[0018]** In an arrangement, as depicted in Figure 2, a pair of protrusions 41 on one of the carrier 12 and the ceiling panel 11 may engage with a corresponding pair of recesses 42 on

the other of the carrier 12 and the ceiling panel 11. Such an arrangement may facilitate a stable engagement of the ceiling panel 11 with the carrier 12.

**[0019]** In an arrangement, the clip 20 may be configured such that at least a part 25 of the clip, between the engagement section 21, 22 and the pressing section 30 is deformed, for example elastically deformed, when the ceiling panel 11 is engaged with the carrier 12. This may generate a force that causes the pressing section 30 to press together the engaged parts of the ceiling panel 11 and the carrier 12.

**[0020]** Figure 3 illustrates in cross-section the operation of the clip 20. The non-dotted representation of the clip 20 shows, in cross-section, the clip 20 when mounted to a carrier 12 in the absence of a ceiling panel 11. As shown, the engagement section 21 of the clip 20 secures the position of the engagement section 21 relative to the carrier 12. The dotted representation, shows the clip 20 when a ceiling panel 11 is engaged with the carrier 12. As shown, the position of the engagement section 21 relative to the carrier 12 is unchanged. The position of the pressing section 30 is moved upwards by the engagement of the ceiling panel 11, introduced to the carrier 12 from below, deforming the part 25 of the clip 20 between the engagement section 21 and the pressing section 20. The deformation of the part 25 of the clip 20 between the engagement section 21 and the present section 30 generates a force that results in the pressing section 30 exerting a force downwards on the ceiling panel 11, pressing together the engaged parts of the ceiling panel 11 and the carrier 12.

**[0021]** It should be appreciated, therefore, that in order to assemble a ceiling system, a user may mount the one or more carriers 12 to a structure from which the ceiling system 10 is to be suspended. Thereafter, at each location at which a ceiling panel 11 is to engage with a carrier 12, a clip 20 may be engaged with the carrier 12, noting as discussed above that it may not be necessary to provide a clip 20 at each such location. The ceiling panels 11 may then be engaged with the carriers 12, by introducing it to the carrier 12 from below and exerting a force sufficient to overcome the pressing force exerted by the pressing section 30 of the clips 20 when engaging the ceiling panels 11 with the carriers 12. In arrangements in which the engagement of the ceiling panel 11 with the carrier 12 requires the engagement of a protrusion into a recess, the engagement of the ceiling panel 11 to the carrier 12 may require sufficiently deforming the clip 20 to enable the insertion of the protrusion into the recess.

**[0022]** As shown in the Figures, in an arrangement, the clip 20 may include two engagement sections 21, 22. This may facilitate the provision of a stable connection to the carrier 12, or ceiling panel 11 in an arrangement in which the clip 20 engages with the ceiling panel 11. For example, as shown in the Figures, the pressing section 30 of the clip 20 may be provided between the two engagement sections 21, 22. It should be appreciated, however, alternative arrangements may be used, in which the clip has a different number of sections that engage with the carrier 12 or ceiling panel 11.

**[0023]** Figures 2 and 3 show more detail of an example of a configuration of the engagement section 21, 22 of a clip 20. As shown, the component that engages with the clip 20, in this case

the carrier 12, includes a hole 15 through which the engagement section 21, 22 passes to engage with the carrier 12. When the clip 20 is engaged with the carrier 12, the engagement section 21, 22 passes through the hole 15 and is arranged such that two portions 23, 24 forming the engagement section 21, 22 are arranged on opposite sides of the hole 15 and extend in opposite directions away from the hole 15. The engagement section 21, 22 is arranged such that at least one of the portions 23, 24 of the wire extending away from the hole 15 presses against the carrier 12 with which it is engaged. This may generate a reaction force that in turn causes the pressing section 30 to press together the engaged parts of the ceiling panel 11 and the carrier 12. As shown in the cross-section of Figure 3, it should be appreciated that in order to generate the reaction force, it is not necessary that both portions 23, 24 of the engagement section 21, 22 that extend away from the hole 15 to contact the carrier 12.

**[0024]** In an arrangement, the carrier 12, or ceiling panel 11 if the engagement section 21, 22 of the clip 20 engages with the ceiling panel 11, may further include an opening 16 through which the engagement section 21, 22 of the clip 20 passes when it is engaged with the carrier 12. In such an arrangement, one portion 23 of the engagement section 21, 22 extends between the hole 15 and the opening 16. In such an arrangement, the opening 16 may be formed as a recess in an edge of the carrier 12. In general, it should be appreciated that the hole 15 and the opening 16 may have any convenient shape.

**[0025]** In such an arrangement, the clip 20 may be engaged with the carrier 12 by inserting a portion 24 of the engagement section 21, 22 through the hole 15 in the carrier 12 and then rotating the clip 20 about the carrier 12 until the second portion 23 of the engagement section 21, 22 makes contact with an outer surface of the carrier 12, as shown in the Figures. Once the clip 20 is assembled to the carrier 12, the portion 23 of the engagement section 21, 22 extending between the hole 15 and the opening 16 may be on the opposite side of the part of the carrier to which the clip 20 is engaged from the pressing section 30. Such an arrangement may enable the clip 20 to be easily assembled to the carrier 12 by a user whilst still providing a secure engagement with the carrier 12.

**[0026]** The clip 20 may be formed from a wire, such as a metal wire. Black spring steel wire may be used. However, other materials that deform elastically may also be used. In an arrangement, the functional part of the clip may be formed only from the wire. The formation of the clip 20 from such a wire may enable easy and cost-effective manufacture of a clip for this use. In particular, it will be appreciated that a wire may be selected that can be deformed plastically in order to have the desired shape but, in use, may deform elastically, for example in order to provide the desired pressing force in order to press together the engaged parts of the ceiling panel 11 and the carrier 12.

## **REFERENCES CITED IN THE DESCRIPTION**

Cited references

This list of references cited by the applicant is for the reader's convenience only. It does not form part of the European patent document. Even though great care has been taken in compiling the references, errors or omissions cannot be excluded and the EPO disclaims all liability in this regard.

**Patent documents cited in the description**

- US4735039A [0002] [0002]
- FR2528889 [0002]
- EP3399118A [0002]

## PATENTKRAV

1. Loftssystem (10) konfigureret til at tilvejebringe en flade, der dækker en underliggende arkitektonisk struktur,

omfattende:

5 mindst ét afdækningspanel (11);

mindst én bærer (12) konfigureret til at understøtte det mindst ene afdækningspanel; og

mindst én klemme (20) konfigureret til at fastgøre det mindst ene afdækningspanel til den mindst ene bærer;

10 hvor afdækningspanelet og bæreren er konfigureret således, at afdækningspanelet kan indføres i bæreren fra siden af fladen tilvejebragt af loftssystemet, der skal i indgreb med en del af bæreren for at gøre det muligt for bæreren at understøtte afdækningspanelet; og

15 klemmen omfatter en længde wire, der indbefatter mindst én indgrebssektion (21, 22) konfigureret til at gå i indgreb med bæreren for at fastgøre indgrebssektionens position i forhold til bæreren; **kendetegnet ved**

20 en pressesektion (30) konfigureret til at udøve en nedadgående kraft mod afdækningspanelet ved at presse mod afdækningspanelet for derved at holde afdækningspanelet i indgreb med bæreren ved at presse de dele af afdækningspanelet og bæreren, der er i indgreb, sammen;

hvor delen af bæreren, der er konfigureret til at gå i indgreb med delen af afdækningspanelet, er konfigureret til at udøve en opadgående kraft mod delen af afdækningspanelet for at understøtte dets vægt.

25 2. Loftssystem ifølge krav 1, hvor mindst én af afdækningspanelet og bæreren omfatter et fremspring (41) konfigureret til at gå i indgreb med en indskæring (42) på den anden af afdækningspanelet og bæreren for at gøre det muligt for bæreren at understøtte afdækningspanelet.

3. Loftssystem ifølge krav 1 eller 2, hvor

klemmen (20) er konfigureret således, at mindst en sektion (25) mellem indgrebssektionen (21, 22) og pressesektionen (30) deformeres, når afdækningspanelet går i indgreb med bæreren, hvorved der genereres en kraft, som bevirker, at pressesektionen presser delene af afdækningspanelet og bæreren, der er i indgreb, sammen.

**4.** Loftssystem ifølge et hvilket som helst af de foregående krav, hvor klemmen omfatter to indgrebssektioner (21, 22).

**5.** Loftssystem ifølge krav 4, hvor pressesektionen (30) tilvejebringes mellem de to indgrebssektioner (21, 22).

**6.** Loftssystem ifølge et hvilket som helst af de foregående krav, hvor bæreren eller afdækningspanel, der går i indgreb med den mindst ene indgrebssektion, omfatter et hul (15), hvorigennem indgrebssektionen passerer for at gå i indgreb med bæreren eller afdækningspanelet.

**7.** Loftssystem ifølge krav 6, hvor den mindst ene indgrebssektion omfatter to dele af den wire, der danner klemmen, som er placeret på modsatte sider af hullet og strækker sig i respektive modsatte retninger væk fra hullet.

**8.** Loftssystem ifølge krav 7, hvor mindst én af delene af den wire, der danner den mindst ene indgrebssektion, er konfigureret til at presse mod den bærer eller det afdækningspanel, som den er i indgreb med, hvorved der genereres en reaktionskraft, der bevirker, at pressesektionen presser delene af afdækningspanelet og bæreren, der er i indgreb, sammen.

**9.** Loftssystem ifølge krav 7 eller 8, hvor bæreren eller afdækningspanel, der går i indgreb med den mindst ene indgrebssektion, omfatter en åbning (16), hvorigennem indgrebssektionen passerer for at gå i indgreb med bæreren eller afdækningspanelet, således at indgrebssektionen omfatter en del af den wire, der danner klemmen, som strækker sig mellem hullet og åbningen.

**10.** Loftssystem ifølge krav 9, hvor åbningen er en indskæring i en kant af bæreren eller afdækningspanelet.

**11.** Loftssystem ifølge krav 9 eller 10, hvor delen af den wire, der strækker sig mellem hullet og åbningen, er på den modsatte side af en del af bæreren eller afdækningspanelet med hullet og åbningen fra pressesektionen.

**12.** Loftssystem ifølge et hvilket som helst af de foregående krav, hvor afdækningspanelet er et dekorativt panel og/eller en ledeplade.

**13.** Fremgangsmåde til samling af et loftssystem (10) ifølge et hvilket som helst af de foregående krav, omfattende:

tilvejebringelse af mindst én bærer (12);

tilvejebringelse af mindst én klemme (20) til bæreren; og

10 montering af mindst ét afdækningspanel på bæreren, således at afdækningspanelet understøttes af en opadgående kraft udøvet af bæreren, og

15 således at klemmen udøver en nedadgående kraft mod afdækningspanelet ved at presse mod afdækningspanelet for derved at holde afdækningspanelet i indgreb med bæreren ved at presse dele af afdækningspanelet og bæreren, der er i indgreb, sammen.

# DRAWINGS

Drawing

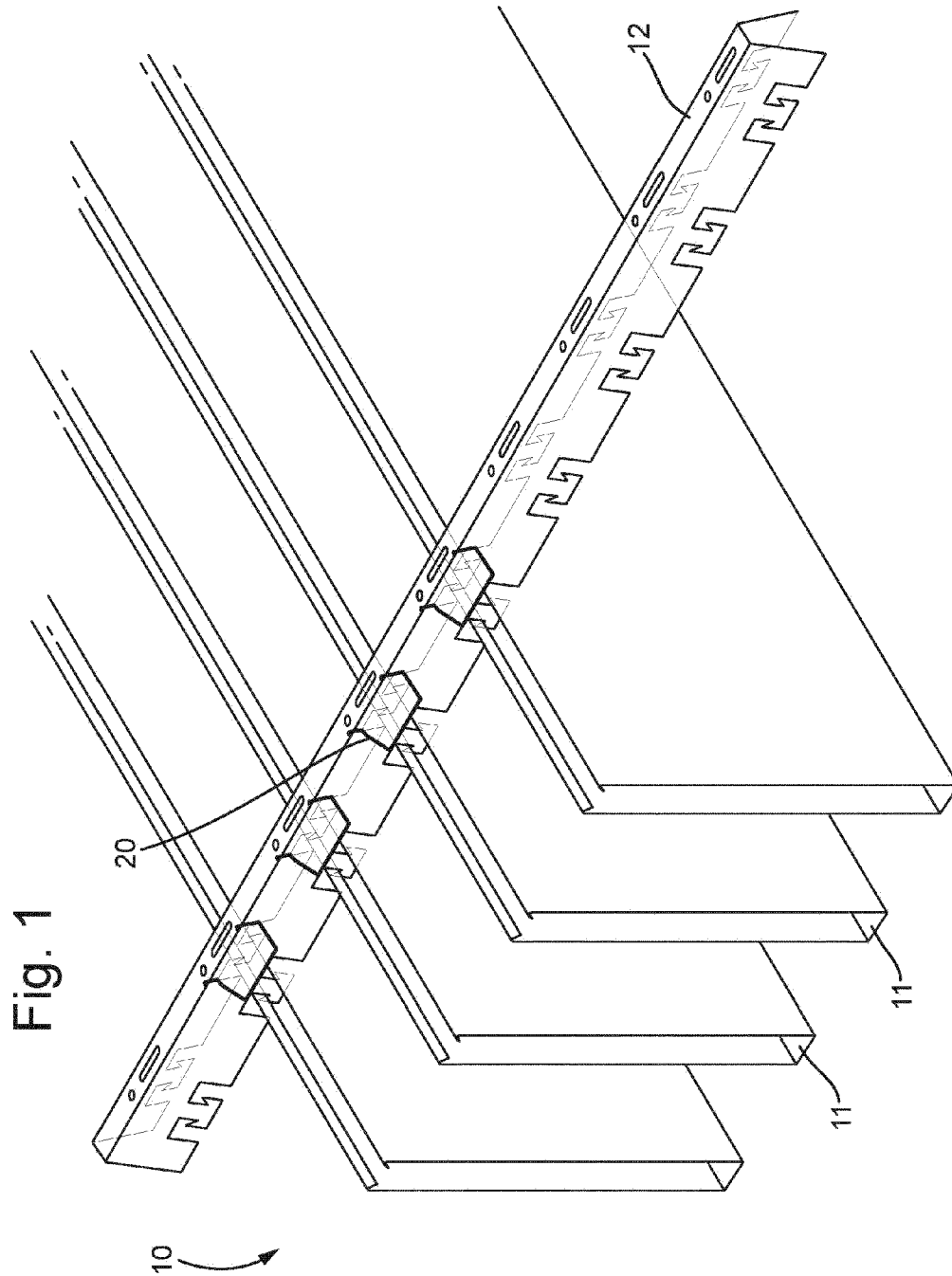

Fig. 2

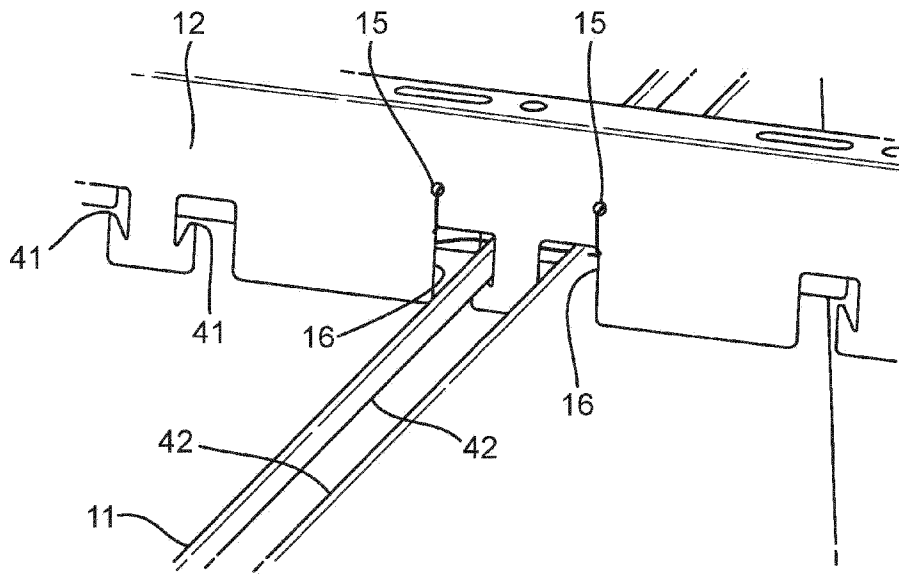

Fig. 3

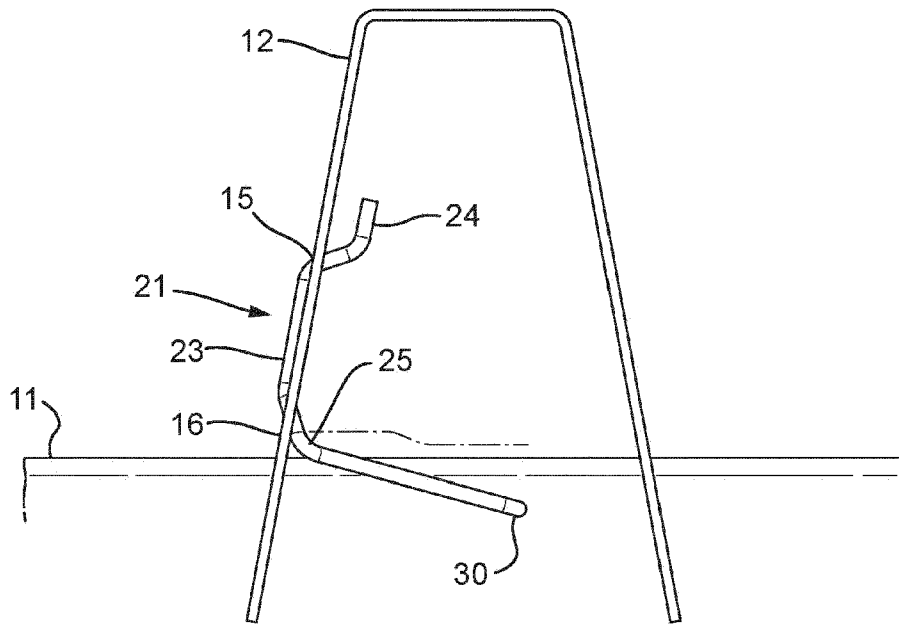

Fig. 4

