

J. VON HENTZEL.
 ELECTRICAL HOT WATER APPARATUS.
 APPLICATION FILED DEC. 16, 1914.

1,166,950.

Patented Jan. 4, 1916.

FIG. 1

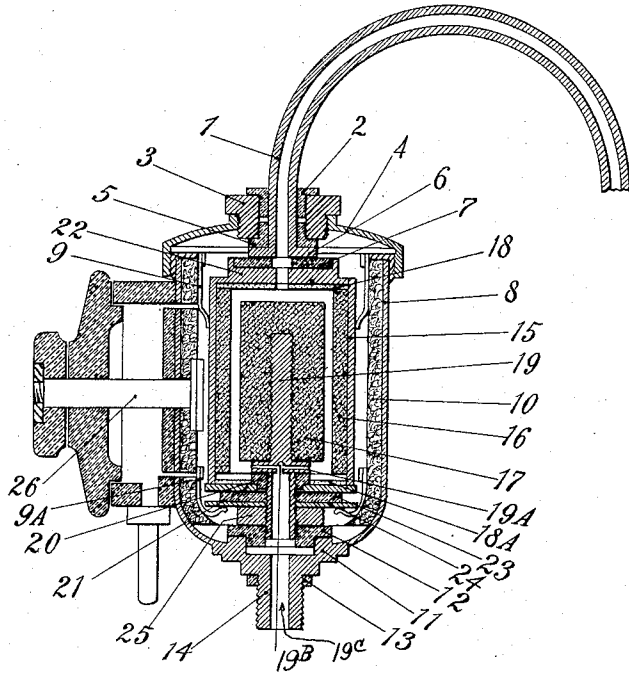
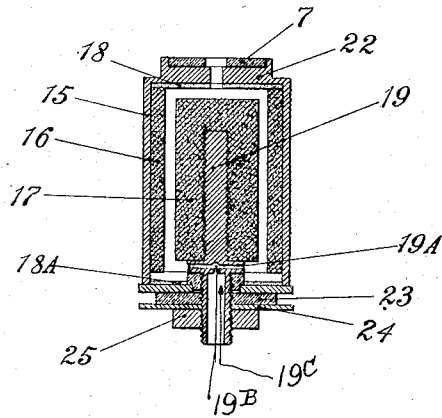

FIG. 2



WITNESSES:
[Signature]
[Signature]

INVENTOR
[Signature]

UNITED STATES PATENT OFFICE.

JOHANN VON HENTZEL, OF NEW YORK, N. Y.

ELECTRICAL HOT-WATER APPARATUS.

1,166,950.

Specification of Letters Patent.

Patented Jan. 4, 1916.

Application filed December 16, 1914. Serial No. 877,533.

To all whom it may concern:

Be it known that I, JOHANN VON HENTZEL, constructing engineer, a subject of Russia, residing in the city, county and State of New York, have invented certain new and useful Improvements in Electrical Hot-Water Apparatus, of which the following is a specification.

The known electrically heated hot water apparatus show many disadvantages and inconveniences in use. The heated water will deposit substances, such as carbonates, sulfates and oxids in the ring-shaped electrode chamber, so that after a short time a conductive connection will be formed between the electrodes. Besides, the electrodes, particularly when direct current is used, are worn after a short time to such an extent that they will cease to act as such. This will prevent the proper working of the apparatus. It will then have to be returned to the manufacturer in order to be taken apart, cleaned and if necessary even be fitted with new electrodes. The user, physician, dentist or person who utilizes the apparatus as a sterilizing agent, will of course suffer by the loss of time. These disadvantages are obviated by the present application an improvement on my Patent #1081114 granted on Dec. 9th, 1913 and on my second application, Serial #810830 filed Jan. 7th, 1914, according to which a readily exchangeable vessel containing the electrodes is fitted on the base containing the water supply, and is secured in this position by a lid being screwed down on it. The water that flows through the space between the electrodes serves as a resistance. The apparatus is supplied with a duplicate vessel which may replace the other one in a very simple manner without any loss of time whatsoever.

In the accompanying drawing the preferred form of hot water apparatus according to the present invention is illustrated as an example.

Figure I is a vertical section through the apparatus. Fig. II is a vertical section through the duplicate part.

The metallic discharge tube 1 is insulated from the nut 3 by the rubber insulator 2 to prevent the passage of heat from one to the other; this nut is also of metal. It is threaded on the outside and is screwed into the metal cap 4. The nut 3 pushes down upon the insulator 5; this insulator 5 presses upon flange 6, which is part of discharge pipe 1;

flange 6 pushes down upon insulator 7 and the entire pressure falls upon the top cover 22 of the inner shell; so that the pressure from the upper portion is so exerted that the entire inner shell presses upon the washer 12 which is found in the inner bottom surface of the outer vessel 11.

5 is a rubber insulator identical with 2, which serves to insulate the lower part of the discharge tube.

6 is the metal flange of the discharge tube; this flange is soldered onto the discharge tube. This flange serves to keep 1 down upon the inside shell. The rubber insulator 7 insulates flange 6 from the cover of the shell 22.

8 is the metallic outer cylinder, the lower part of which is oval shaped. This cylinder holds the connection 14 for the inlet tube. The cap of the cylinder shown as 4 also of metal is screwed down on the cylinder proper.

10 is a fiber insulator used to insulate the outer cylinder from the inner shell, but between the insulation and inner shell is found a cylindrical air gap.

The current leads are shown as 9 and 9^A, 9 being positive and 9^A negative. The current leads are attached to the fiber insulator 10. The current leads 9 press against the wall of the inner vessel 15, while the current leads 9^A touch from underneath the metal washer 24. Thus the inner vessel 15 is held in place by the current leads 9 and 9^A. The lower part, 11, of the outer cylinder is bored to make room for the rubber washer 12, upon which rests the inner shell. 13 is also a rubber washer.

15 is the metallic cylindrical casing of the inner shell.

16 is the outer hollow cylindrical electrode, which is fitted tightly into the shell, the inner electrode is shown at 17; this electrode 17 is composed of magnetic iron oxid. The mica insulators 18 and 18^A are used to insulate the under surface of the cover of the shell and also to insulate the upper surface of the bottom of the shell. The main purpose of these two mica insulators is to protect the metal from oxidizing influence resulting from electric currents in the water. The upper portion of the metallic pin 19 is threaded to receive and hold firmly the electrode 17. The lower part of the pin 19 has an inner bore 19^C, which opens into the diametric bore 19^B in the flange 19^A

which acts as an exit through which water passing up from the inlet pipe 14 flows through the annular space which is found between the two electrodes and then out through the discharge tube.

20 is a rubber insulator used to insulate the lower portion of the pin from the under surface of the flange and from the base of the shell 21.

21 and 22, which are the covers of the shell, are both soldered on to the shell proper; the insulator 7 previously mentioned rests directly on the cover 22.

23 is a rubber insulator, insulating 21 from the metallic washer 24. This washer serves as an electric conductor since it is in electrical contact with both pin 19 and the electrode 17 and the current lead 9^A. The hexagonal nut 25 holds together the insulators 20, 23, the metallic washer 24 and the flange 19^A.

26 is the controlling switch for the device.

Fig. II is the duplicate vessel which, when necessary, can be exchanged without any appreciable loss of time.

I claim:

Apparatus for heating liquids by elec-

tricity, comprising an outer casing, closure caps at each end of said casing, inlet and outlet liquid connections for said closure caps, arranged centrally thereof, a detachable electrode member within the casing, comprising an inner casing open at both ends, of smaller size than the outer casing, an electrode therein having, at the lower end and centrally thereof an opening for the passage of liquids, in direct communication with the inlet connection of one of the closures, a hollow cylindrical electrode spaced outwardly around the inner electrode for forming a conduit for the liquid and having an opening in the upper end thereof in direct communication with the outlet of one of the closure caps, means supporting the said electrodes, and insulating means insulating the electrodes from the outer casing.

Signed at New York city, in the county of New York, and State of New York, this 15th day of December, A. D. 1914.

JOHANN von HENTZEL.

Witnesses:

JOHN VALASOUR NEAL,
HENRY E. HOFFMANN.

Copies of this patent may be obtained for five cents each, by addressing the "Commissioner of Patents, Washington, D. C."