

(19) World Intellectual Property Organization
International Bureau



(43) International Publication Date
26 July 2007 (26.07.2007)

PCT

(10) International Publication Number
WO 2007/083115 A1

(51) International Patent Classification:
A61M 5/20 (2006.01)

(21) International Application Number:
PCT/GB2007/000141

(22) International Filing Date: 17 January 2007 (17.01.2007)

(25) Filing Language: English

(26) Publication Language: English

(30) Priority Data:
0601309.8 23 January 2006 (23.01.2006) GB
0602411.1 7 February 2006 (07.02.2006) GB
0605644.4 21 March 2006 (21.03.2006) GB
11/387,645 22 March 2006 (22.03.2006) US
0620163.6 12 October 2006 (12.10.2006) GB

(71) Applicant (for all designated States except US): **THE MEDICAL HOUSE PLC** [GB/GB]; 199 Newhall Road, Sheffield S9 2QJ (GB).

(72) Inventor; and

(75) Inventor/Applicant (for US only): **STAMP, Kevin** [GB/GB]; 57 Greenhead Gardens, Chapeltown, Sheffield S35 1AR (GB).

(74) Agent: **STAINTHORPE, Vanessa, Juliet**; Harrison Goddard Foote, Fountain Precinct, Balm Green, Sheffield S1 2JA (GB).

(81) Designated States (unless otherwise indicated, for every kind of national protection available): AE, AG, AL, AM, AT, AU, AZ, BA, BB, BG, BR, BW, BY, BZ, CA, CH, CN, CO, CR, CU, CZ, DE, DK, DM, DZ, EC, EE, EG, ES, FI, GB, GD, GE, GH, GM, GT, HN, HR, HU, ID, IL, IN, IS, JP, KE, KG, KM, KN, KP, KR, KZ, LA, LC, LK, LR, LS, LT, LU, LV, LY, MA, MD, MG, MK, MN, MW, MX, MY, MZ, NA, NG, NI, NO, NZ, OM, PG, PH, PL, PT, RO, RS, RU, SC, SD, SE, SG, SK, SL, SM, SV, SY, TJ, TM, TN, TR, TT, TZ, UA, UG, US, UZ, VC, VN, ZA, ZM, ZW.

(84) Designated States (unless otherwise indicated, for every kind of regional protection available): ARIPO (BW, GH, GM, KE, LS, MW, MZ, NA, SD, SL, SZ, TZ, UG, ZM, ZW), Eurasian (AM, AZ, BY, KG, KZ, MD, RU, TJ, TM), European (AT, BE, BG, CH, CY, CZ, DE, DK, EE, ES, FI, FR, GB, GR, HU, IE, IS, IT, LT, LU, LV, MC, NL, PL, PT, RO, SE, SI, SK, TR), OAPI (BF, BJ, CF, CG, CI, CM, GA, GN, GQ, GW, ML, MR, NE, SN, TD, TG).

Declaration under Rule 4.17:

— of inventorship (Rule 4.17(iv))

Published:

— with international search report

For two-letter codes and other abbreviations, refer to the "Guidance Notes on Codes and Abbreviations" appearing at the beginning of each regular issue of the PCT Gazette.

(54) Title: IMPROVED AUTOINJECTOR SUPPORTING THE SYRINGE AT THE FRONT

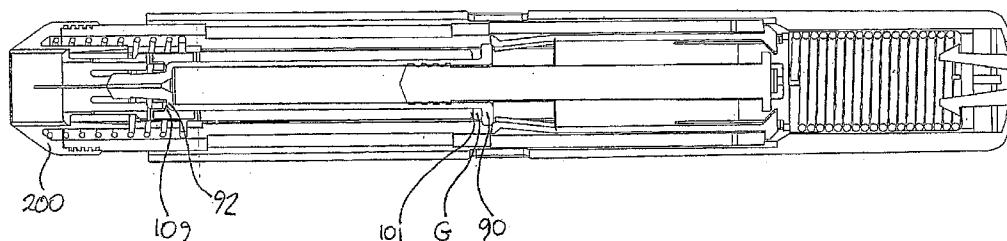

(57) Abstract: An autoinjector comprising a housing in which can be mounted a syringe comprising a barrel for holding a volume of medicament, a needle at one end of the barrel in fluid communication with the medicament and a plunger axially-moveable in the barrel to a forwardmost position, the autoinjector further comprising a syringe support means for supporting the barrel at an axial location at or forward of the forwardmost position of the plunger and having a reaction surface for the syringe, whereby in use said reaction surface (109) provides an axial compressive force on said barrel when a forward axial force is applied to the plunger.

WO 2007/083115 A1

IMPROVED AUTOINJECTOR SUPPORTING THE SYRINGE AT THE FRONT

5 This invention relates to the field of autoinjectors for the administration of liquid medication, for example, interferon.

BACKGROUND

10 An autoinjector is an automatic injection device designed to facilitate automated delivery of a dose of medicament to a patient through a hypodermic needle, the injection usually being administered by the patient themselves. An autoinjector works, for example, by delivering an injection automatically upon actuation by the patient pressing a button, moving a lever or part of a housing etc. This is in contrast to a conventional manual
15 syringe where the patient himself needs to directly depress a plunger into a barrel containing medicament in order to effect the injection. The terms "autoinjector" and "injection device" are used interchangeably in the following description.

Examples of autoinjectors are described in WO2003/099358 (Seedlings Life Science
20 Ventures LLC) and WO01/93926 (Mayo Foundation for Medical Education and Research). These are both generally flat devices which are of small size to encourage users to carry the device with them for ready access. GB2396298 (PA Consulting Services Ltd) is an example of a more conventionally-shaped elongate autoinjector, but of relatively complex internal construction.

25

All three of the above prior art devices have a custom designed medicament chamber therein rather than being built around a standard pre-filled syringe presentation. The custom medicament chamber, although allowing for a compact overall size for the device, means that the device as whole must be subjected to more rigorous regulatory
30 control as compared with a device containing a standard pre-filled syringe presentation which will have already obtained regulatory approval.

Another reason why the above prior art cannot be used in conjunction with a standard syringe presentation is related to the needle. Usually, a standard pre-filled syringe
35 presentation to be used within a disposable autoinjector includes a needle in communication with a medicament chamber contained within the barrel of the syringe. It

is essential that the sterility and integrity of the needle is maintained and protected right up until the moment it is required to deliver an injection. Usually this is achieved by providing a needle sheath comprising a solid (for example an elastomer such as rubber) sheath into which the needle is staked or spiked so that it is surrounded and sealed on all sides. Usually, at least the forwardmost 3-4mm of the needle is embedded in the rubber of the needle sheath. The autoinjector cannot be operated with the needle sheath in place. Immediately prior to actuating the device, the user removes the needle sheath, for example by removing an endcap from the device to which the needle sheath is attached, so that the needle is ready for use. In contrast, WO01/93926 for example has an entirely different type of needle sheath 79 which is designed to be ruptured by the forward-moving needle during use of the autoinjector. In other words, this type of rupturable needle sheath does not need to be removed from the device before actuation, however, such needle sheaths are likely to provide less mechanical protection than those provided in a standard pre-filled syringe presentation and usually do not directly maintain sterility of the medicament and the needle.

In general, an autoinjector includes a needle which is located within the housing of the device. Upon activation of a force-generating source, a portion of the needle extends out of the housing and penetrates the outer layer of skin to deliver medicament. In some known autoinjectors, after activation, a needle cover or needle shield moves forward to conceal the the needle after use. In GB2396298, the needle automatically retracts back into the housing by means of a biasing spring.

An improved autoinjector is described in our co-pending international patent application, published under number WO 2005/070481. Some of the reference numerals in the present application correspond with the equivalent components in the device described in WO 2005/070481. This device requires that the needle is moved axially so that it can appear beyond the end of the nozzle for the duration of the injection, after which the needle retracts automatically, so that it is never in sight of the user. The device also requires that the plunger is moved axially so that medicament is ejected. The overall complexity of the autoinjector is significantly reduced by both of these requirements being effected by one component, namely an inner housing and the device has the significant advantage that it can be built around a conventional or standard syringe presentation.

The injection device of WO 2005/070481 is designed to be used in conjunction with a standard drug presentation e.g. a pre-filled syringe comprising a needle, barrel pre-filled with medicament and a plunger. The plunger may include a separately-provided plunger rod. As mentioned above, there is a significant commercial advantage in being able to use a standard pre-filled syringe, which will have been subjected to numerous clinical trials, drug stability studies and regulatory approval. Any modification to the standard syringe may require further trials and approval, adding delay and expense. The present invention is relevant to any injection device for use in conjunction with a standard pre-filled syringe presentation (whether preloaded or not and whether single-use or reusable), not only the device described in WO 2005/070481.

The barrel of a syringe is usually glass, since glass has the most favourable storage properties for many drugs. However, glass is notoriously fragile and there is a risk of damage or breakage of the syringe during injection if the forces to which the syringe is subjected by the injection device are not properly controlled. This is particularly so where the liquid medicament is relatively viscous, requiring greater force to expel it from the syringe via the needle. Barrels made of materials other than glass, for example polyethylene or cyclic olefin polymers are less brittle when subjected to normal forces during injection, but still would benefit from the invention described below.

In the known device described in our co-pending patent application no WO 2005/070481 and illustrated in Figures 1-3 of the present application, the syringe is supported within the injection device by a barrel or syringe holder 9. The syringe holder 9 comprises an elongate housing which closely surrounds the glass barrel of the syringe. The annular flange 90 at the rear of the syringe barrel rests on a barrel seat 91 at the rear of the syringe holder 9. The annular flange 90 at the rear of the syringe barrel is often referred to as a "finger flange" because, during a conventional (manual) injection using a syringe, the user's index and middle fingers rest naturally in front of the "finger flange" in order to provide the necessary resistance to allow depression of the plunger by the thumb to deliver the medicament.

The barrel seat, for example in the form of an annular flange, preferably prevents forward axial movement of the syringe with respect to the syringe holder so that, in use, the syringe barrel and the syringe holder move axially together as one unit.

In use, as described in WO 2005/070481, there are three stages of delivering an injection. Before delivering an injection (referring to Figure 1 of the present application), the end cap 15 is pulled off, removing the needle cover 17 (if present) and rubber needle sheath 16 with it from the needle. In the first stage of delivering an injection, as shown in Figure 2 of the present application, the tags 7B at the forward end of the inner housing 7 are in contact with the syringe barrel 90, which is pushed axially forward (taking the syringe holder 9 with it), so that the needle 10, which is fixed to the front end of the barrel, moves in the direction indicated by the arrow so that eventually it protrudes beyond the nozzle 11 at the front of the device. Forward travel of the barrel and syringe holder is limited when a surface 9A of the syringe holder reaches an endstop 11A inside the nozzle or front housing 11.

Referring now to Figure 3, the second stage of the injection is the delivery of the medicament wherein the tags 7A at the rear of the inner housing 7 depress the plunger 8 into the barrel of the syringe. During this stage, the barrel of the syringe is held axially stationary, by abutment of the annular "finger" flange 90 against the barrel seat 91, which results in the barrel being placed in tension as the plunger pushes the non-compressible liquid medicament towards the forward end of the barrel. This tension is undesirable in a glass barrel, which may become damaged or broken, especially if the medicament comprises a particularly viscous liquid which requires greater force to expel it from the syringe via the needle. Viscous medicaments are desirable in certain applications, where the use of a sustained-release viscous medicament reduces the frequency that an injection is required.

It is desirable to minimise the diameter of the needle so far as is possible, because the smaller the diameter of the needle, the less painful is the resulting injection. However, for a given length of needle, the smaller the needle diameter, the greater the force required to eject the medicament from the syringe.

It is also desirable to minimise the duration of the injection, i.e. to maximise the speed at which the medicament is delivered from the syringe. Particularly when the needle diameter is small, minimising the duration of the injection also means an increase in the force used to eject the medicament from the syringe.

An increase in the forces on the syringe consequently increases the likelihood of the syringe breaking during the injection. The risk of the syringe breaking during injection is

significant, and is not only inconvenient and costly but is also potentially dangerous. If breakage occurs, it is possible that glass fragments and/or the needle may become detached and exit the front of the device causing injury. Furthermore, there is the risk that the remaining medicament will leak or be ejected from the device in an uncontrolled manner, potentially delivering the wrong dose into the patient, or causing injury e.g. if the medicament contacts the patient's skin or eyes. These problems are amplified when the medicament is viscous as a more powerful energy source is needed in such applications so that the forces involved are greater. It is known that a typical breakage of the syringe during injection would occur at the finger flange, whereby the finger flange 90 on the syringe barrel breaks as a result of its abutment against the barrel seat 91. It is therefore highly desirable to minimise the likelihood of breakage of the syringe.

In the third stage of the injection (not illustrated in the present application but shown in WO 2005/070481), once the medicament has been delivered and the inner housing 7 is no longer in contact with the barrel or plunger of the syringe, the secondary spring 12 pushes the syringe holder (and hence the syringe contained therein) axially rearwardly so as to retract the syringe back into the housing so that the used needle is concealed from view.

20 SUMMARY OF THE INVENTION

According to a first aspect of the present invention, there is provided an autoinjector comprising a housing in which can be mounted a syringe comprising

- 25 a barrel for holding a volume of medicament,
- a needle at one end of the barrel in fluid communication with the medicament,
- a plunger axially-moveable in the barrel to a forwardmost position,

the autoinjector further comprising

- 30 a needle sheath which seals the forwardmost end of the needle to maintain sterility of the medicament within the barrel whereby, in use, the needle sheath must be removed from the needle immediately prior to actuating the autoinjector; and

- a syringe support means for supporting the barrel at an axial location at or forward of the forwardmost position of the plunger and having a reaction surface for the syringe, whereby in use said reaction surface provides an axial compressive force on said barrel when a forward axial force is applied to the plunger.

Preferably, the autoinjector is a single-use autoinjector. The simple construction of the autoinjector makes it very appropriate for applications such as emergency use for injecting a large population to control a pandemic, where a large number of cost-effective disposable autoinjectors are required. A single-use autoinjector also provides
5 a very convenient means for patients to administer their own injections, even if lacking in dexterity and/or clinical experience. Delivery of viscous drugs is particularly problematic for patients lacking dexterity because of the greater force needed to deliver such drugs – this problem being alleviated by the present invention.

10 Typically, the autoinjector contains an energy source, for example a coiled spring, for moving said plunger axially in the barrel to deliver an injection in less than 30 seconds.

Preferably, the syringe is axially moveable in said housing and is biased so that the needle is normally wholly inside said housing, wherein before injection the syringe is
15 movable axially so as to move at least a part of said needle out of the housing and wherein after injection, the syringe is able to retract in order to retract said part of said needle into the housing. The concealment of the needle both before and after injection makes the autoinjector particularly suitable where the patient has any aversion to injection by needle. Retraction and retention of the needle after injection eliminates the
20 risk of needle-stick injury.

According to a second aspect of the invention there is provided a method of assembling an autoinjector comprising the steps of:

25 providing a first part-assembly comprising a front housing and a closely fitting end cap;

providing a second part-assembly comprising a rear part of the autoinjector;

providing a syringe comprising a barrel for holding a volume of medicament, a needle at one end of the barrel and a plunger axially-moveable in the barrel to a forwardmost position;

30 providing a syringe support means;

inserting the syringe axially into the rear end of the syringe support means until said syringe support means supports the syringe;

inserting the front end of said syringe and syringe support means into said first part-assembly;

35 assembling said first part-assembly and second part-assembly together so that said syringe support means supports the syringe at an axial location at or forward of the

forwardmost position of the plunger, whereby in use said reaction surface provides an axial compressive force on said barrel when a forward axial force is applied to the plunger.

5 According to a third aspect of the invention there is provided a method of assembling an autoinjector comprising the steps of:

providing a first part-assembly comprising a syringe support means, a front housing and a closely fitting end cap;

providing a second part-assembly comprising a rear part of the autoinjector;

10 providing a syringe comprising a barrel for holding a volume of medicament, a needle at one end of the barrel and a plunger axially-moveable in the barrel to a forwardmost position;

inserting the syringe axially into the rear end of the first part-assembly until said syringe support means supports the syringe;

15 assembling said first part-assembly and second part-assembly together so that said syringe support means supports the syringe at an axial location at or forward of the forwardmost position of the plunger, whereby in use said reaction surface provides an axial compressive force on said barrel when a forward axial force is applied to the plunger.

20

Further features of the invention are defined in the appended claims.

BRIEF DESCRIPTION OF THE DRAWINGS

25 Preferred embodiments of the present invention will now be more particularly described, by way of example only, with reference to the accompanying drawings in which:

Figure 1 (PRIOR ART) is a perspective view of a known injection device;

30 Figure 2 (PRIOR ART) is a plan view, partly in section of the Figure 1 device, with the cap and needle cover removed, ready for actuation;

Figure 3 (PRIOR ART) is a plan view, partly in section of the Figure 1 device, with the needle exposed, ready for the plunger to be depressed in order to deliver the
35 medicament;

Figure 4 is a perspective view of an injection device embodying one aspect of the present invention;

5 Figure 5 is a plan view, partly in section of the Figure 4 device, with the cap, needle cover and needle sheath removed, ready for actuation;

Figure 6 is a plan view, partly in section of the Figure 4 device, with the needle exposed, ready for the plunger to be depressed in order to deliver the medicament;

10 Figure 7 is a perspective view of the syringe holder;

Figure 8 is a cross-sectional view of the syringe holder of Figure 7;

15 Figure 9 is a cross-section view of the syringe holder of Figure 7, showing a syringe in place;

Figure 10 is a cross-section view of the syringe holder of Figure 7, showing a syringe, needle sheath and needle cover in place;

20 Figure 11 shows detail, drawn to a larger scale, of the interface between the front of the glass syringe barrel and the syringe holder illustrated in Figure 10;

25 Figure 12, drawn to a larger scale, is a cross-sectional view of the modified front housing;

Figure 13, drawn to a larger scale, is a perspective cross-sectional view of the front housing;

30 Figure 14 is a cross-sectional view of the front housing, cap and syringe holder assembled together;

Figure 15 is a perspective view of the front housing, cap and syringe holder assembled together;

35 Figure 16 is a cross-sectional view of the front housing, cap, syringe holder and syringe assembled together;

Figure 17 is a cross-sectional view of an alternative embodiment of the syringe holder;

Figure 18 is a part-assembly view showing the syringe holder of Figure 17 together with
5 its spring retainer, a syringe therein and the end cap and front housing;

Figure 19 shows the part-assembly of Figure 18 with the needle cover removed;

Figure 20 is a perspective view of the syringe holder of Figure 17 together with its spring
10 retainer;

Figure 21 is a perspective view of a syringe holder, end cap and front housing, showing
an alternative means of retaining the gripping means against the syringe barrel;

15 Figure 22 is a perspective view of another embodiment of the syringe holder together
with a needle cover.

DETAILED DESCRIPTION

20 Throughout the description and claims of this specification, the words “comprise” and
“contain” and variations of the words, for example “comprising” and “comprises”, means
“including but not limited to”, and is not intended to (and does not) exclude other
components, integers or steps.

25 Throughout the description and claims of this specification, the singular encompasses
the plural unless the context otherwise requires. In particular, where the indefinite article
is used, the specification is to be understood as contemplating plurality as well as
singularity, unless the context requires otherwise.

30 Throughout the following description, reference to a “forward” direction means the
direction which is towards the patient when the injection device is in use. The “forward”
end of the injection device is the end nearest the patient’s skin when the device is in use.
Similarly, reference to a “rearward” direction means the direction which is away from the
patient and the “rearward” end of the device is the end furthest from the patient’s skin
35 when the injection device is in use.

The "plunger" includes any elastomeric stopper or the like which seals the chamber containing liquid medicament. The plunger typically also includes a plunger rod but this may be provided separately from the elastomeric stopper and need not be an essential part of the syringe. The "forwardmost position" of the plunger refers to the forwardmost position of any part of the plunger (typically the forwardmost edge of the stopper).

Features, integers, characteristics or groups described in conjunction with a particular aspect, embodiment or example of the invention are to be understood to be applicable to any other aspect, embodiment or example described herein unless incompatible therewith.

As described above, a disadvantage of the known prior art is that the barrel of the syringe is placed in tension as the plunger pushes the non-compressible liquid medicament towards the forward end of the barrel for delivery. This tension is undesirable in a glass barrel, which may become damaged or broken, especially if the medicament comprises a particularly viscous liquid which requires greater force to expel it from the syringe. There is a possibility that the glass syringe might break in the region of its finger flanges, as a result of the forces to which it is subjected during delivery of an injection. One way to mitigate this problem is to reduce the effect of those forces in the region of the finger flanges. For example, the syringe holder of WO 2005/070481 can be modified by providing a helical slit at the rear end thereof which, in use, provides resilience to the region of the barrel seat on which is located the finger flange of the syringe (not illustrated). The resilient flexing absorbs shock and reduces the risk of breakage of the syringe in the region of the finger flanges.

Other means for reducing the effect of forces in the region of the finger flanges can be envisaged, for example, providing a cushion in the form of an O-ring or moulding a relatively soft or elastomeric material into a harder substrate in the region of the barrel seat.

It is known that a typical breakage of the syringe during injection would occur at the finger flange, whereby the finger flange 90 on the syringe barrel breaks as a result of its abutment against the barrel seat 91. However, the applicant has recognised that it is also possible that the syringe could break at points on the barrel forward of the finger flange. This is potentially more serious as larger straight glass fragments may be

ejected from the front of the device, as well as the unsecured needle, and any remaining medicament will leak out in an uncontrolled manner.

5 The risk of breakage or damage to the glass syringe may be reduced by ensuring that the barrel is held in compression during delivery of the medicament (stage two of the injection process described in WO 2005/070481), rather than being in tension. This can be achieved by supporting the forward end of the barrel and having a reaction surface at which an axial compressive force can be applied to the barrel when a forward axial force is applied to the plunger during delivery of the medicament.

10

In the injection device of the present invention, the conventional syringe holder 9 is replaced with a more complex syringe holder which is capable of supporting the syringe at the front end of its barrel instead of at its rear flange 90 during delivery of the medicament. In the embodiment described below, the syringe holder supports the syringe at the front shoulder of its barrel and provides a reaction surface there for the front shoulder of the barrel. By "front shoulder" is meant the region at which the largest diameter of the barrel reduces to a smaller diameter at the nozzle. The front shoulder 92 is indicated in Figure 9. Alternatively, the syringe could be supported and the reaction surface provided at the front end of the syringe barrel, or at the narrowed "cone" where the needle is attached thereto and these embodiments are described in more detail below. The syringe can, in fact, be supported at any place on the barrel which, in use, is forward of the forwardmost position of the fully-depressed syringe plunger and where a reaction surface for the syringe can be provided (so that the barrel is held in compression throughout the delivery of the medicament).

25

However, the desired supporting or holding of the barrel by the syringe holder at its front end presents an assembly difficulty for a product where it is desired to keep manufacturing and assembly costs to a minimum. In the prior art device, the syringe can simply be dropped into the rear end of the syringe holder until its flange 90 rests on the barrel seat 91. This determines the axial position of the syringe with respect to the syringe holder. In practice, the prior art syringe holder is supplied ready-assembled with the front part of the device, so that the pre-filled syringe can simply be dropped into the syringe holder and then the front part of the device (including the syringe) can be attached to the ready-assembled rear part of the device in a simple two-stage assembly operation.

35

In the present invention, it is not possible to use the finger flange 90 and barrel seat to determine the axial position of the syringe with respect to the syringe holder. This is because the syringe holder needs to actively support the syringe at its front end (preferably at the front shoulder 92 of the glass barrel). In the preferred embodiment there are inwardly-directed gripping means to retain the front shoulder of the glass barrel at a specific axial location with respect to the syringe holder. The standard syringe is usually supplied with a needle cover 17 which typically has a diameter almost the same as the largest diameter of the glass barrel (see Figure 10). The needle cover 17 may be rigid, but is not necessarily so. Inside the needle cover 17, the needle is staked or spiked inside a needle sheath 16, which may be made from rubber. If the syringe is inserted into the syringe holder needle-first (or rather needle-cover first), any inwardly-directed gripping means would foul on the needle cover (or needle sheath if no needle cover is present) as they attempt to pass. There is also the risk of the needle being damaged during assembly, for example if it is pushed into any inwardly-directed gripping means. Such damage to the needle is highly undesirable, as it could cause injury to the patient or could affect or impede delivery of medicament, in particular because it often cannot be readily detected if the needle is concealed within a needle cover and/or a rubber needle sheath. The damage to the needle may only become apparent during delivery of the medicament. The consequent effect of a damaged needle on delivery of medicament may not be apparent to the patient at all.

This problem is solved by the use of a syringe holder 100 as illustrated in Figures 7 and 8. The syringe holder 100 comprises an elongate rear portion 102 in which there are viewing windows 103 so that the medicament chamber in the barrel of a syringe held therein would be visible. There is a barrel seat 101 (equivalent to barrel seat 91 in the prior art device) at the rear end of the rear portion 102, but in practice this is not intended to abut the flange 90 of the syringe barrel (unlike in the prior art device).

The syringe holder also has an intermediate portion 105 of comparable diameter to the rear portion, and a front portion 106 of narrower diameter. The intermediate portion 105 is provided with a discontinuous annular flange 104. Together, the intermediate and front portions 105, 106 include radially-spaced slots 107 which define a plurality of radially flexible fingers 108. In the illustrated embodiment, there are three flexible fingers 108, but four or some other number of fingers may be provided. Figure 22 shows an embodiment in which four flexible fingers 108 are provided on the syringe holder 100. The four fingers necessarily each are thinner than those in the three-finger embodiment.

A typical example of a needle cover 17 is shown in Figure 22 (illustrated without the rest of the syringe for simplicity). The needle cover has a slot 17A therein. If the syringe holder 100 is appropriately aligned with the needle cover of a syringe held therein, there is a possibility that one of the relatively thin flexible fingers 108 may undesirably snag or drop into slot 17A, possibly causing damage to the underlying needle that would not become apparent until an injection is delivered. This disadvantage can be overcome by ensuring that each of the flexible fingers 108 is preferably wider than the needle cover slot 17A, as illustrated by the three-finger embodiment of Figure 7.

As shown in Figure 8, gripping means 109 preferably in the form of a discontinuous annular inwardly-directed protrusion, are provided on the interior of the flexible fingers 108 in the intermediate section 105. Referring to Figure 9, when a syringe is located within the syringe holder 100, the gripping means 109 abuts the front shoulder 92 of the barrel in order to define the axial position of the barrel with respect to the syringe holder.

The term "gripping means" is not limited to means which grip radially-inwardly onto the barrel, although in some embodiments they may do so. More important is the fact that the gripping means 109 (or equivalent) supports the syringe in a desired axial location and provides a reaction surface for the syringe so that the barrel will be held in compression during delivery of the medicament.

As can be seen from Figures 10 and 11, the needle cover 17 has a greater diameter than the diameter normally available at the gripping means 109. In other words, the internal diameter between the gripping means 109 is smaller than the exterior diameter of the needle cover 17. However, as will be explained in more detail below, when the syringe is inserted into the syringe holder, as the needle cover 17 passes the gripping means 109, the flexible fingers 108 flex radially-outwardly to create sufficient diameter for the needle cover to pass the inwardly-protruding gripping means, without exerting excessive force on the needle therein, thus minimising the risk of damage to the needle. Once the needle cover has passed, the flexible fingers 108 spring back into their normal position (having smaller internal diameter than the exterior diameter of the needle cover) and the gripping means 109 locate at the front shoulder 92 of the barrel to provide the reaction surface against which the syringe will be held in compression during delivery of the medicament. In this position, the gripping means 109 are axially located between the needle cover and the front shoulder of the barrel.

The front portion 106 of the syringe support 100 is provided with a plurality of (preferably two) equispaced tags 110, whose purpose will be described later below.

The most straightforward way to assemble the syringe and injection device is in a three stage procedure, namely:

1. inserting the syringe into the syringe holder, until the gripping means 109 locate at the front shoulder 92 of the barrel;
2. inserting the syringe and syringe holder into the front part of the injection device;
3. assembling the front part to the rear part of the injection device.

Compared with the two-stage assembly procedure of the prior art device, the extra assembly stage is disadvantageous but initially seems necessary as it is not obvious how stages 1 and 2 could be readily combined so that the syringe holder can be supplied ready-assembled with the front part of the device. This is because, once assembled into the front part of the device, the flexible fingers 108 would be prevented from flexing radially outwardly by their necessarily close abutment with the front housing, thus preventing insertion of the syringe and needle cover.

Therefore, in a further embodiment of the invention, a modified front housing for the injection device is provided which enables a two-stage assembly procedure to be used.

The modified front housing 200 (analogous to nozzle 11 in the prior art) is illustrated in Figure 12. The front housing 200 has a bore 201, of sufficient diameter to allow passage therethrough of the needle 10, needle cover 17 and the front and intermediate portions 105, 106 of the syringe holder (but not the flange 104).

The interior surface of the bore 201 is provided with two (or more) equispaced longitudinal slots 202, each having a rear section 203 with a tapered surface providing a varying depth and a forward section 204 of substantially constant depth. The boundary between the forward and rear sections of each slot 202 is defined by a step 205.

The slots 202 are positioned so that they can be aligned with the tags 110 at the front portion of the syringe holder.

The slots 202 enable the syringe holder 100 to be assembled into the front housing 200 at a specific axial position (relative to the front housing) so that the flexible fingers 108 stand clear of the front housing instead of being surrounded therein.

- 5 The slots 202 also provide radial location for the syringe holder 100 as it is inserted therein.

Figure 14 shows a modified end cap 300 (analogous to end cap 15 in the prior art) designed for use with the modified front housing 200 and how the syringe holder 100 is inserted into the front housing 200. The front housing 200 is inserted into the end cap 300 so that its leading surface 206 abuts the interior of the end cap, so that no further forward movement of the front housing within the end cap is possible.

15 The close abutment of the end cap 300, front housing 200 and syringe holder 100 means that, if present, the needle cover 17 is retained securely in position such that the risk of the needle cover accidentally becoming loose or detached is minimised, thereby minimizing possible loss of integrity of the seal between the rubber needle sheath and the needle, which would otherwise compromise the sterility of the medicament contained within the syringe. The carefully engineered interaction between the components avoids the risk that during assembly, the syringe holder 100 might undesirably "snap" in between front end of the syringe barrel and the rear of the needle cover in such a way as to compromise the seal between the end of the needle and the needle sheath in which it is staked.

25 The end cap has an upstanding annulus 301 which protrudes into and is a close fit in the bore 201 of the front housing 200. The upstanding annulus 301 has two equispaced protrusions on the exterior surface thereof which locate in longitudinal slots 202 when the end cap and front housing are assembled together. Once assembled together, the upstanding annulus of the end cap and the step 205 together define a space 302 into which tags 110 on the syringe holder 100 can locate.

35 In order to insert the syringe holder 100 into the front housing 200, the tags 110 are aligned with and pushed into the slots 202 until the tags 110 "click" over the step 205 and locate in the space 302. This is the position illustrated in Figures 14 and 15. Now the syringe holder 100 is suitably axially located such that the gripping means 109 and flexible fingers 108 are not constrained within the front housing 200 and end cap 300.

The front housing, end cap and syringe holder are supplied in this ready-assembled condition, together with the ready-assembled rear part of the injection device, for final assembly with a pre-filled syringe.

5

It is therefore a straightforward two-stage procedure to finally assemble the syringe into the device, namely:

- 10 1. inserting the syringe into the ready-assembled front housing, end cap and syringe holder until the gripping means 109 locate at the front shoulder 92 of the barrel (as shown in Figure 16);
2. assembling the front part to the ready-assembled rear part of the injection device (not illustrated).

15 Figures 4-6 show the fully assembled injection device including syringe holder 100. With reference to Figure 5, it can be seen that (unlike in the prior art device) the flange 90 of the barrel does not contact the barrel seat 101 of the syringe holder 100, there being a gap G therebetween. This is a result of the relative axial positions of the syringe holder and syringe being determined at the front end, by gripping means 109 and front shoulder
20 92 and means that undesirable tension is not applied to the glass barrel during delivery of the medicament.

An alternative embodiment of the syringe holder is illustrated in Figures 17-20. Where possible, the same reference numerals as were used in relation to Figures 8-9 are used
25 to identify like components of the alternative embodiment. Note that Figures 17-20 show the front end of the device at the left side of the Figures, whereas Figures 8-9 show the front end of the device at the right side of the Figures.

In the Figure 17 embodiment of the syringe holder 100', the radially-flexible fingers 108'
30 have their free ends extending in the forward direction (compare with the radially-flexible fingers 108 in Figure 8 which have their free ends extending in the rearward direction). The gripping means comprise inwardly-directed enlarged heads 109' at the end of the flexible fingers 108. As is best seen in Figure 19, the enlarged heads 109' are capable of gripping the cone 93 at the front of the syringe barrel. The cone 93 is the region
35 where the needle 10 is attached to the syringe barrel.

As shown in Figure 18, when a syringe is assembled with the syringe holder 100', the needle cover 17 (which is of comparable diameter to the syringe barrel) causes the flexible fingers 108' to flex radially-outwardly so that the enlarged heads 109' rest on the exterior of the needle cover 17.

5

When the end cap 300 and needle cover 17 are removed axially in the direction of the arrow in Figure 18, the enlarged heads 109' should move radially-inwardly into contact with the cone 93 of the syringe so as to grip the front end of the barrel to provide the compressive force during injection. However, if the flexible fingers 108' are made from plastic and if the device is stored in the Figure 18 configuration for many months before use (both of which are likely), it is possible that the fingers 108' will no longer automatically flex properly inwardly upon removal of the needle cover 17.

10

Therefore, a spring retainer 111 is provided. The spring retainer 111 is made from steel, other metal or other material which does not significantly lose its resilience over time. The spring retainer has elongate fingers which cooperate with the flexible fingers 108' so as to urge them radially-inwardly. Once the needle cover 17 has been removed, the spring retainer 111 urges the enlarged heads 109' into firm contact with the cone 93 of the syringe, even if the flexible fingers 108' are no longer capable of doing so. This position is illustrated in Figures 19 and 20.

15

20

As illustrated in Figure 21, the gripping means (109 or 109') could alternatively be provided in the form of a clip 112, inserted axially into a slot 113 in the syringe holder so as to clip onto the front of the barrel.

25

Other means of providing a reaction surface for the front of the barrel so as to provide a compressive force during injection can be envisaged, for example a tapered elastomeric bush which could be snapped into place once the needle cover has passed during assembly. It may be possible to grip the frontmost part of the cone, where the needle enters the cone, rather than gripping the exterior thereof. Alternatively, other means for gripping the front shoulder of the barrel, or the exterior of the cone may be envisaged.

30

It is observed that the viewing windows 103, 103' in the syringe holder are apertures which create space through which glass fragments could move in the event of a breakage. If a breakage occurs, it is highly desirable to contain any glass fragments so as to minimise the risk of injury. Therefore, in an alternative embodiment (not

35

illustrated), the apertures of the viewing windows are replaced by a solid but transparent or partially transparent material which still permits the user to view the interior of the syringe. Either the apertures 103, 103' can be "filled" with a transparent material so as to form a window in the more conventional sense of the word; alternatively, all of part of
5 the syringe holder may be manufactured from transparent or partially transparent material.

The reader's attention is directed to all papers and documents which are filed concurrently with or previous to this specification in connection with this application and
10 which are open to public inspection with this specification, and the contents of all such papers and documents are incorporated herein by reference.

All of the features disclosed in this specification (including any accompanying claims, abstract and drawings), and/or all of the steps of any method or process so disclosed,
15 may be combined in any combination, except combinations where at least some of such features and/or steps are mutually exclusive.

Each feature disclosed in this specification (including any accompanying claims, abstract and drawings), may be replaced by alternative features serving the same, equivalent or
20 similar purpose, unless expressly stated otherwise. Thus, unless expressly stated otherwise, each feature disclosed is one example only of a generic series of equivalent or similar features.

The invention is not restricted to the details of any foregoing embodiments. The
25 invention extends to any novel one, or any novel combination, of the features disclosed in this specification (including any accompanying claims, abstract and drawings), or to any novel one, or any novel combination, of the steps of any method or process so disclosed.

CLAIMS

1. An autoinjector comprising a housing in which can be mounted a syringe comprising
5 a barrel for holding a volume of medicament,
a needle at one end of the barrel in fluid communication with the medicament,
a plunger axially-moveable in the barrel to a forwardmost position,
the autoinjector further comprising
10 a needle sheath which seals the forwardmost end of the needle to maintain
sterility of the medicament within the barrel whereby, in use, the needle sheath must be
removed from the needle immediately prior to actuating the autoinjector; and
a syringe support means for supporting the barrel at an axial location at or
15 forward of the forwardmost position of the plunger and having a reaction surface for the
syringe, whereby in use said reaction surface provides an axial compressive force on
said barrel when a forward axial force is applied to the plunger.
2. The autoinjector of claim 1 wherein said needle sheath substantially covers said
needle to protect the needle from mechanical damage.
- 20 3. The autoinjector of claim 1 or claim 2 wherein said needle sheath entirely covers
said needle and seals against the syringe to maintain sterility of the external surface of
the needle.
4. The autoinjector of any of the preceding claims wherein said needle sheath
25 comprises a solid elastomeric material into which the needle is spiked.
5. The autoinjector of any of the preceding claims wherein said needle sheath is
capable of being removed from the needle in an axially-forward direction immediately
prior to actuating the autoinjector.
30
6. The autoinjector of any of the preceding claims wherein said needle sheath is
contained within a needle cover.
7. The autoinjector of any of the preceding claims wherein said autoinjector is a
35 single-use autoinjector.

8. The autoinjector of any of the preceding claims further comprising an energy source for moving said plunger axially in the barrel to deliver an injection in less than 30 seconds.
- 5 9. The autoinjector of any of the preceding claims wherein the syringe is axially moveable in said housing and is biased so that the needle is normally wholly inside said housing, wherein before injection the syringe is movable axially so as to move at least a part of said needle out of the housing and wherein after injection, the syringe is able to retract in order to retract said part of said needle into the housing.
- 10 10. The autoinjector of any of the preceding claims wherein, in use, said reaction surface provides an axial compressive force to the front shoulder of the syringe barrel.
- 15 11. The autoinjector of any claims 1-9 wherein, in use, said reaction surface provides an axial compressive force to the front cone of the syringe barrel.
12. The autoinjector of any of the preceding claims wherein said syringe support means includes one or more inwardly-directed protrusions forming said reaction surface.
- 20 13. The autoinjector of claim 12 wherein said inwardly-directed protrusions are on the end of one or more radially-flexible fingers.
14. The autoinjector of claim 13 wherein said inwardly-directed protrusions comprise an inwardly-directed enlarged head on the or each radially-flexible finger.
- 25 15. The autoinjector of claim 13 or claim 14 further comprising a spring retainer, preferably made from steel, for urging the or each radially-flexible finger inwardly.
16. The autoinjector of any of claims 12-15 wherein the internal diameter between
30 said inwardly-directed protrusions is smaller than the exterior diameter of the syringe barrel.
17. The autoinjector of claim 16 wherein, when the device is fully assembled ready
35 and the front shoulder of the syringe barrel.

18. The autoinjector of any of the preceding claims wherein said syringe support means is generally cylindrical and of a diameter less than the diameter of the finger flange of the syringe barrel so that the syringe support means is suitably sized to closely surround the barrel of the syringe, in use.
- 5
19. The autoinjector of any of the preceding claims wherein said syringe support means is capable of supporting said syringe barrel at a specific axial location with respect thereto.
- 10 20. The autoinjector of any of the preceding claims wherein said syringe support means includes one or more viewing windows, to permit a user to view the barrel of a syringe supported therein.
- 15 21. The autoinjector of claim 20 wherein said one or more viewing windows comprise one or more apertures in the syringe support means.
22. The autoinjector of claim 20 wherein said one or more viewing windows comprise a transparent or partially transparent part of the syringe support means.
- 20 23. The autoinjector of any of the preceding claims wherein said syringe support means further comprises one or more alignment tags at the front end thereof.
24. The autoinjector of claim 23 further comprising a front housing having a bore therethrough, the interior surface of the bore being provided with one or more
25 longitudinal slots, positioned so that said alignment tags can locate therein, when said front housing and syringe support means are assembled together.
- 25 25. The autoinjector of claim 24 wherein the or each longitudinal slot comprises a rear section having a forwardly-increasing depth and a forward section having
30 substantially constant depth.
26. The autoinjector of claim 25 wherein a boundary between the rear and forward sections is defined by a step.
- 35 27. The autoinjector of claim 26 further comprising an end cap having internal protrusions therein which protrude into the longitudinal slots in the bore of the front

housing, when said end cap and said front housing are assembled together, so that a space is defined between said internal protrusions in the end cap and said step in the front housing.

- 5 28. The autoinjector of claim 27 wherein the alignment tags of the syringe support means locate into said defined space to determine the axial location of the syringe support means with respect to said front housing.
- 10 29. The autoinjector of any of claims 24-28 wherein said syringe support means includes a radially-extending flange, of greater diameter than the interior diameter of said front housing.
- 15 30. The autoinjector of any of claims 27-29 wherein, when assembled together, said end cap, front housing and syringe support substantially prevent damage to or movement of a needle cover and/or said needle sheath on the needle of a syringe mounted in the device.
- 20 31. The autoinjector of any of the preceding claims wherein the finger flange of the syringe barrel does not contact the syringe support means during delivery of the medicament.
- 25 32. The autoinjector of any of the preceding claims when dependent on claim 13, wherein said radially-flexible fingers can flex sufficiently outwardly to allow a needle cover, said needle sheath or the like of larger diameter than the internal diameter between said radially-flexible fingers to pass thereby during assembly of a syringe into said autoinjector.
- 30 33. The autoinjector of claim 32 when dependent on claim 28 wherein said axial location of the syringe support means with respect to the front housing is such that said radially-flexible fingers are not confined within said front housing and are free to flex radially, when the front housing and syringe support means are assembled together and before assembly of a rear part-assembly of the autoinjector thereto.
- 35 34. The autoinjector of claim 32 wherein, when the device is fully assembled ready for use, said inwardly-directed protrusions closely abut the needle cover and/or said

needle sheath to reduce the risk of said needle sheath becoming loose or detached from the needle, potentially compromising the sterility of the needle.

35. The autoinjector of any of the preceding claims wherein the housing is an outer housing and at least part of the needle is axially moveable in and out of said outer housing but is biased to be normally wholly inside said housing, the autoinjector further comprising:

an inner housing intermediate the outer housing and the barrel and plunger; and
an energy source in communication with said inner housing,
wherein the inner housing is moveable by the energy source between three positions, namely

a first position in which the inner housing is in communication with the barrel such that, in use, the plunger and barrel are movable axially so as to move at least part of said needle out of the outer housing;

a second position in which the inner housing is in communication with the plunger but not the barrel such that, in use, said plunger is movable axially into said barrel so as to expel medicament through the needle; and

a third position in which the inner housing is in communication with neither the plunger nor the barrel such that, in use, the plunger and barrel are able to retract in order to retract the needle into the outer housing.

36. The autoinjector of claim 35 wherein said inner housing includes one or more flexible tags, biased radially inwardly by communication with said outer housing.

37. The autoinjector of claim 36 wherein one or more of said tags are situated at the rear end of the inner housing and are biased radially inwardly into communication with the plunger.

38. The autoinjector of claim 37 wherein each rear tag is moveable out of communication with the plunger when aligned with a corresponding recess in the outer housing.

39. The autoinjector of claim 36 wherein one or more of said tags are situated at the forward end of the inner housing and are biased radially inwardly into communication with the barrel.

40. The autoinjector of claim 39 wherein each forward tag is moveable out of communication with the barrel when aligned with a corresponding recess in the outer housing.
- 5 41. The autoinjector as claimed in any of the preceding claims, in which is mounted a syringe comprising
- a barrel for holding a volume of medicament,
 - a needle at one end of the barrel in fluid communication with said medicament
- and
- 10 a plunger axially-moveable in the barrel to a forwardmost position.
42. The autoinjector substantially as described herein with reference to and as illustrated in any appropriate combination of Figures 4-22.
- 15 43. A method of assembling an autoinjector comprising the steps of:
- providing a first part-assembly comprising a front housing and a closely fitting end cap;
 - providing a second part-assembly comprising a rear part of the autoinjector;
 - providing a syringe comprising a barrel for holding a volume of medicament, a
- 20 needle at one end of the barrel and a plunger axially-moveable in the barrel to a forwardmost position;
- providing a syringe support means having a reaction surface for the syringe;
 - inserting the syringe axially into the rear end of the syringe support means until said syringe support means supports the syringe ;
- 25 inserting the front end of said syringe and syringe support means into said first part-assembly;
- assembling said first part-assembly and second part-assembly together so that said syringe support means supports the syringe at an axial location at or forward of the forwardmost position of the plunger, whereby in use said reaction surface provides an
- 30 axial compressive force on said barrel when a forward axial force is applied to the plunger.
44. A method of assembling an autoinjector comprising the steps of:
- providing a first part-assembly comprising a syringe support means, a front
- 35 housing and a closely fitting end cap;
- providing a second part-assembly comprising a rear part of the autoinjector;

providing a syringe comprising a barrel for holding a volume of medicament, a needle at one end of the barrel and a plunger axially-moveable in the barrel to a forwardmost position;

5 inserting the syringe axially into the rear end of the first part-assembly until said syringe support means supports the syringe;

10 assembling said first part-assembly and second part-assembly together so that said syringe support means supports the syringe at an axial location at or forward of the forwardmost position of the plunger, whereby in use said reaction surface provides an axial compressive force on said barrel when a forward axial force is applied to the plunger.

45. A method of assembling an autoinjector substantially as described herein with reference to and as illustrated in any appropriate combination of Figures 4-22.

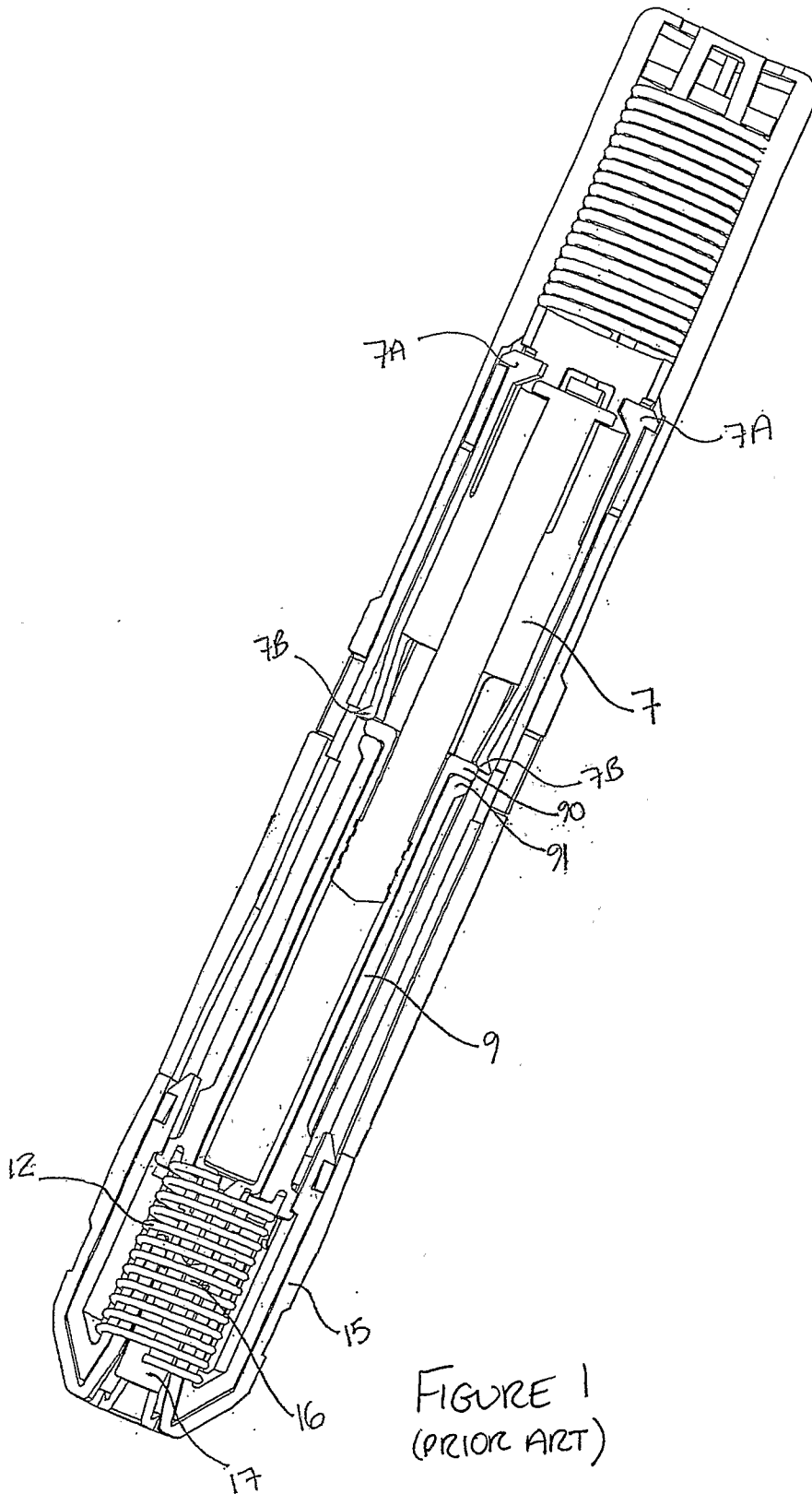

2/22

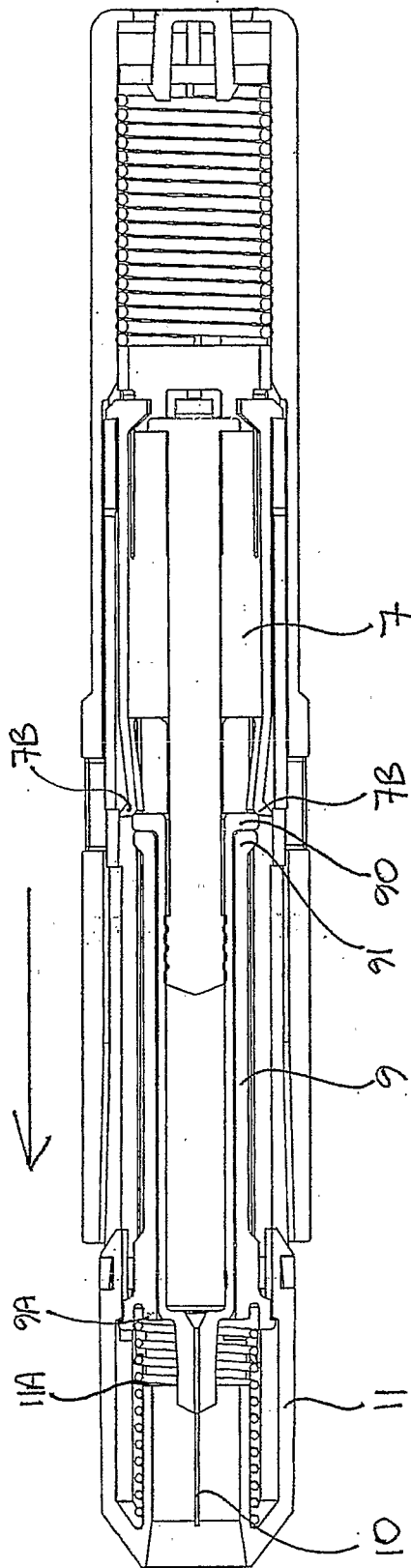

FIGURE 2
(PRIOR ART)

3/22

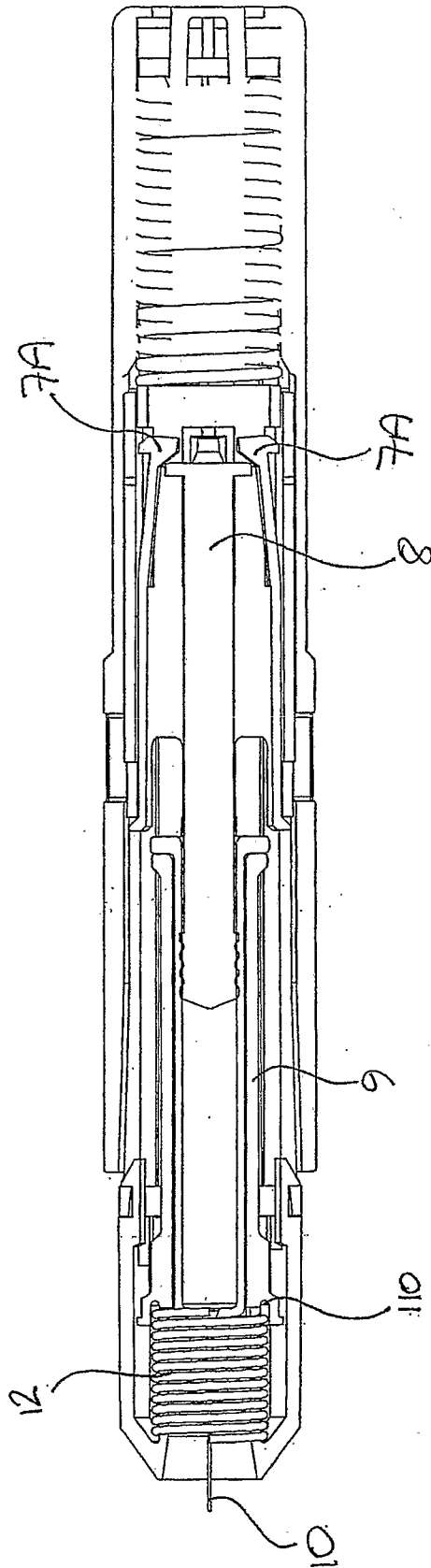

FIGURE 3
(PRIOR ART)

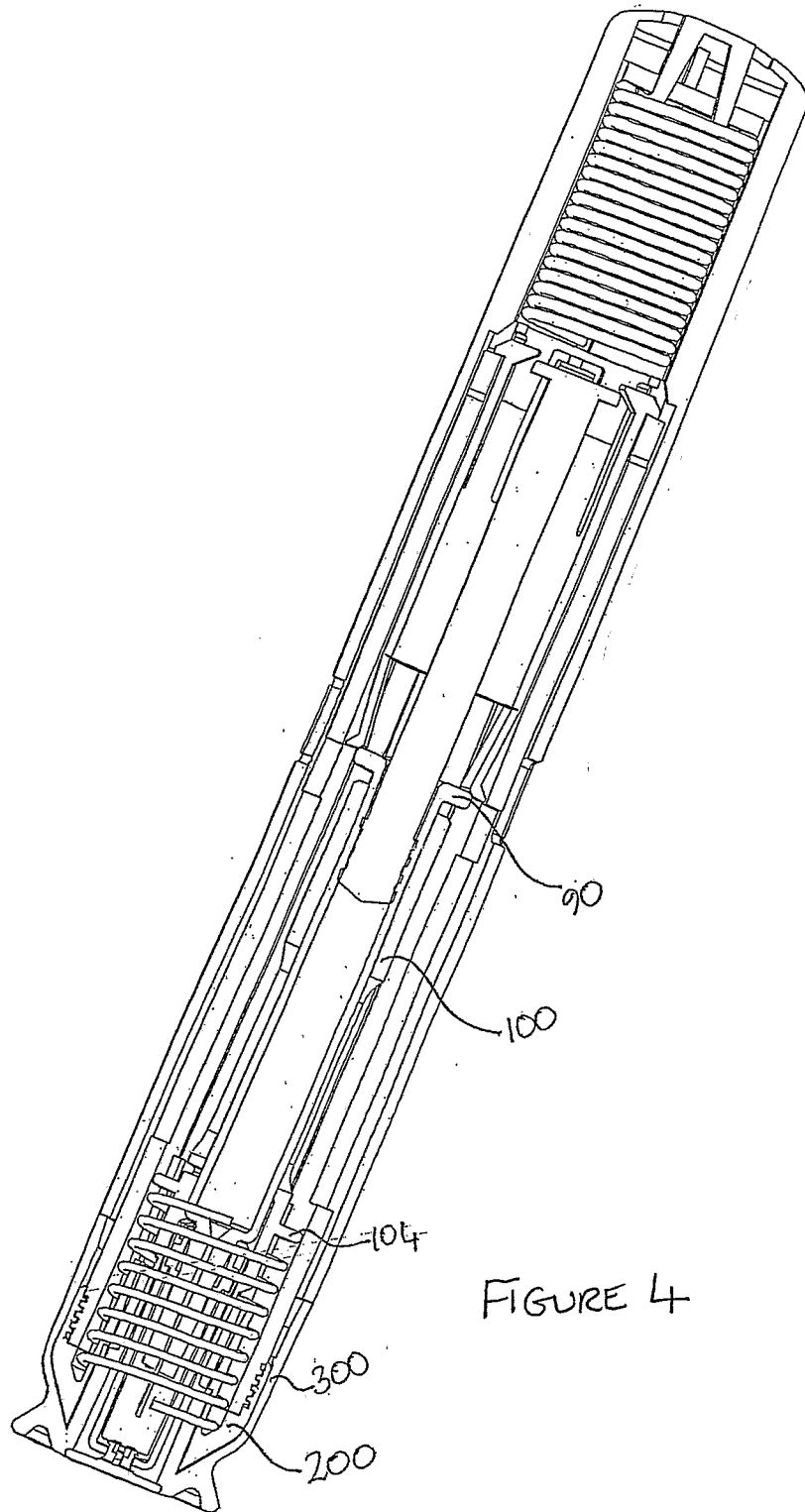

FIGURE 4

5/22

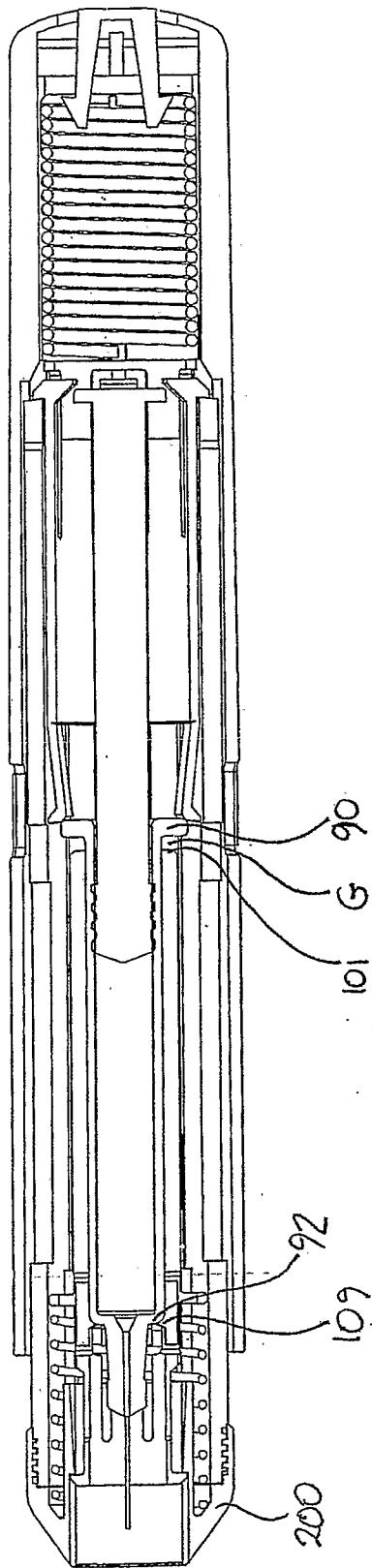

FIGURE 5

6/22

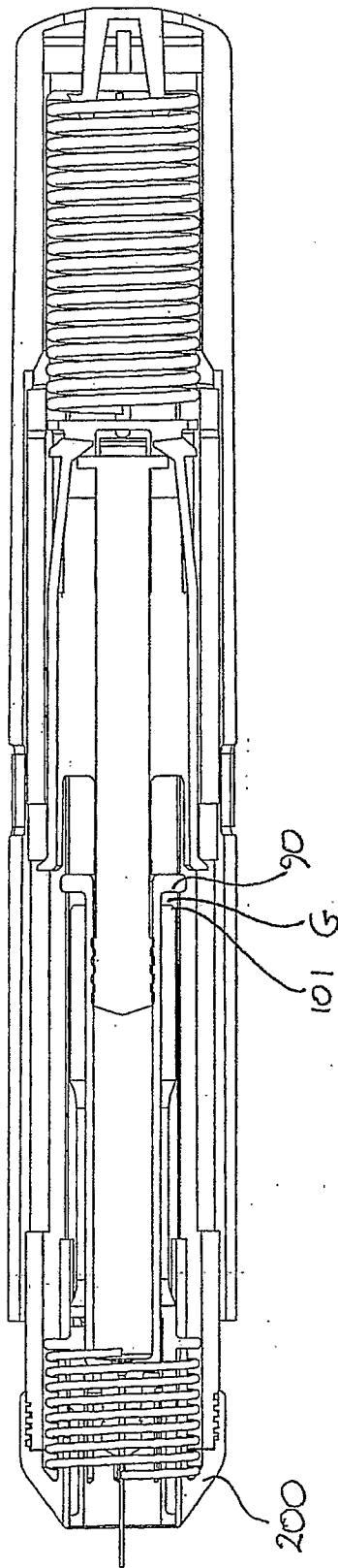

FIGURE 6

7/22

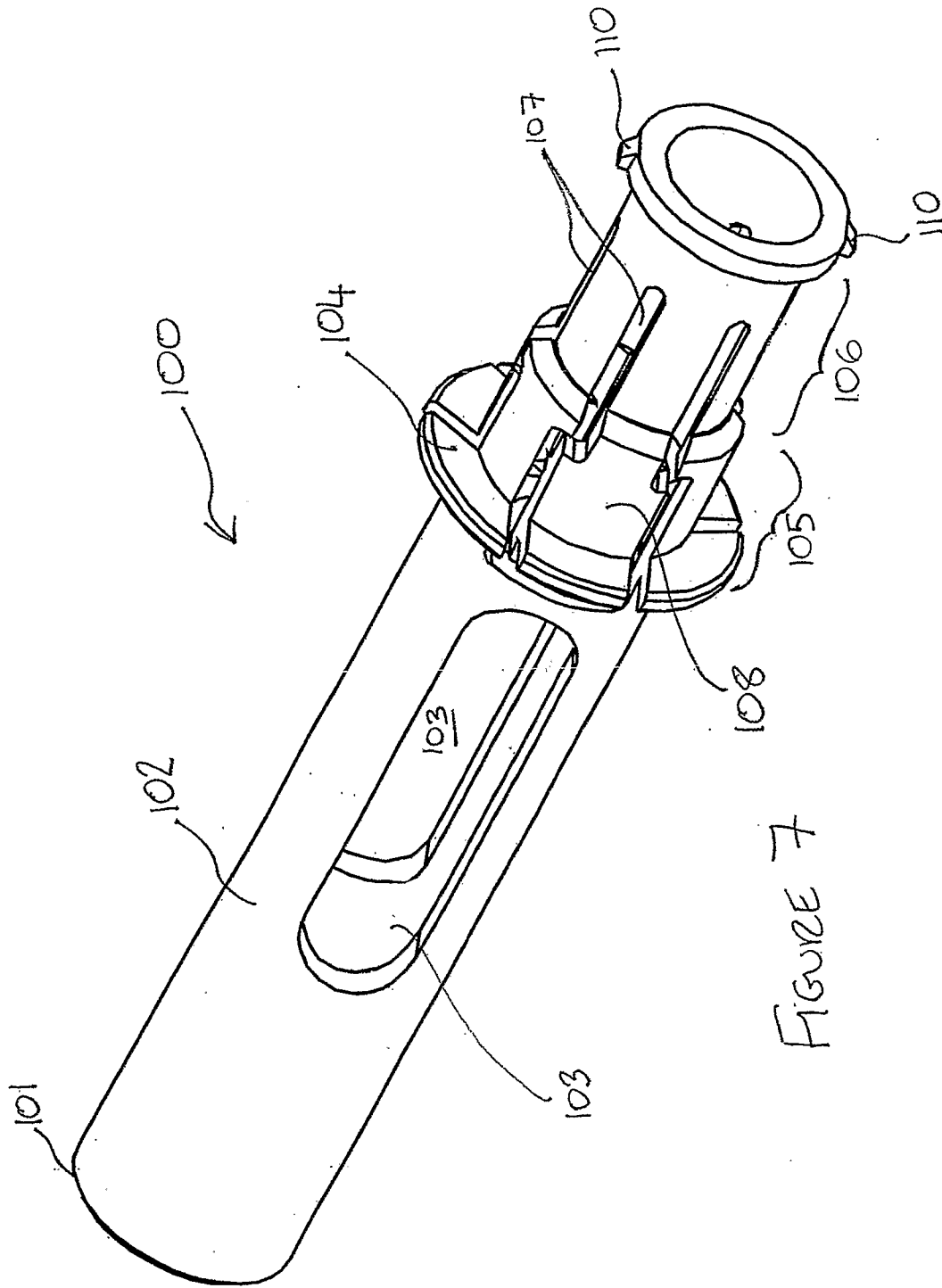

FIGURE 7

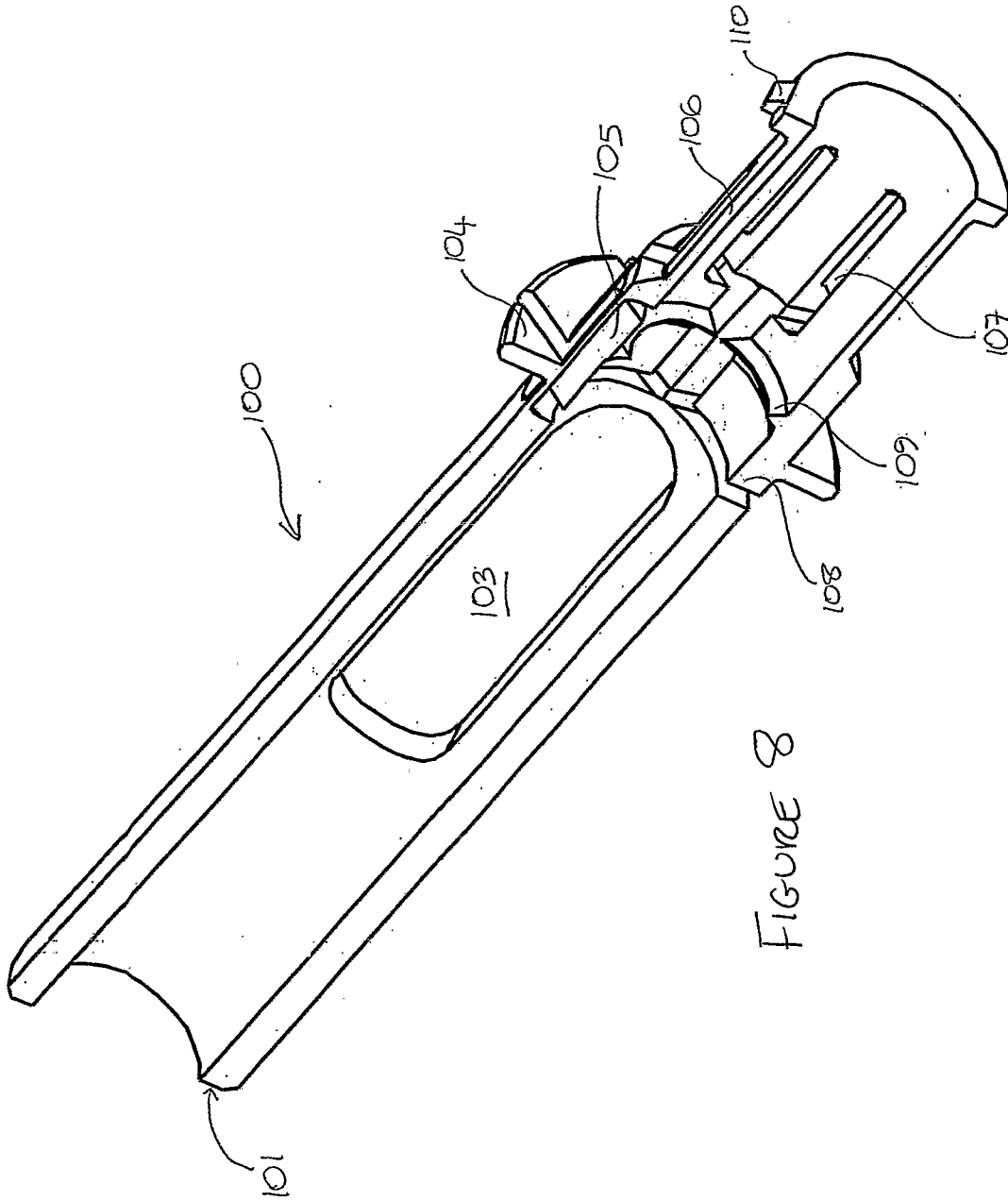

FIGURE 8

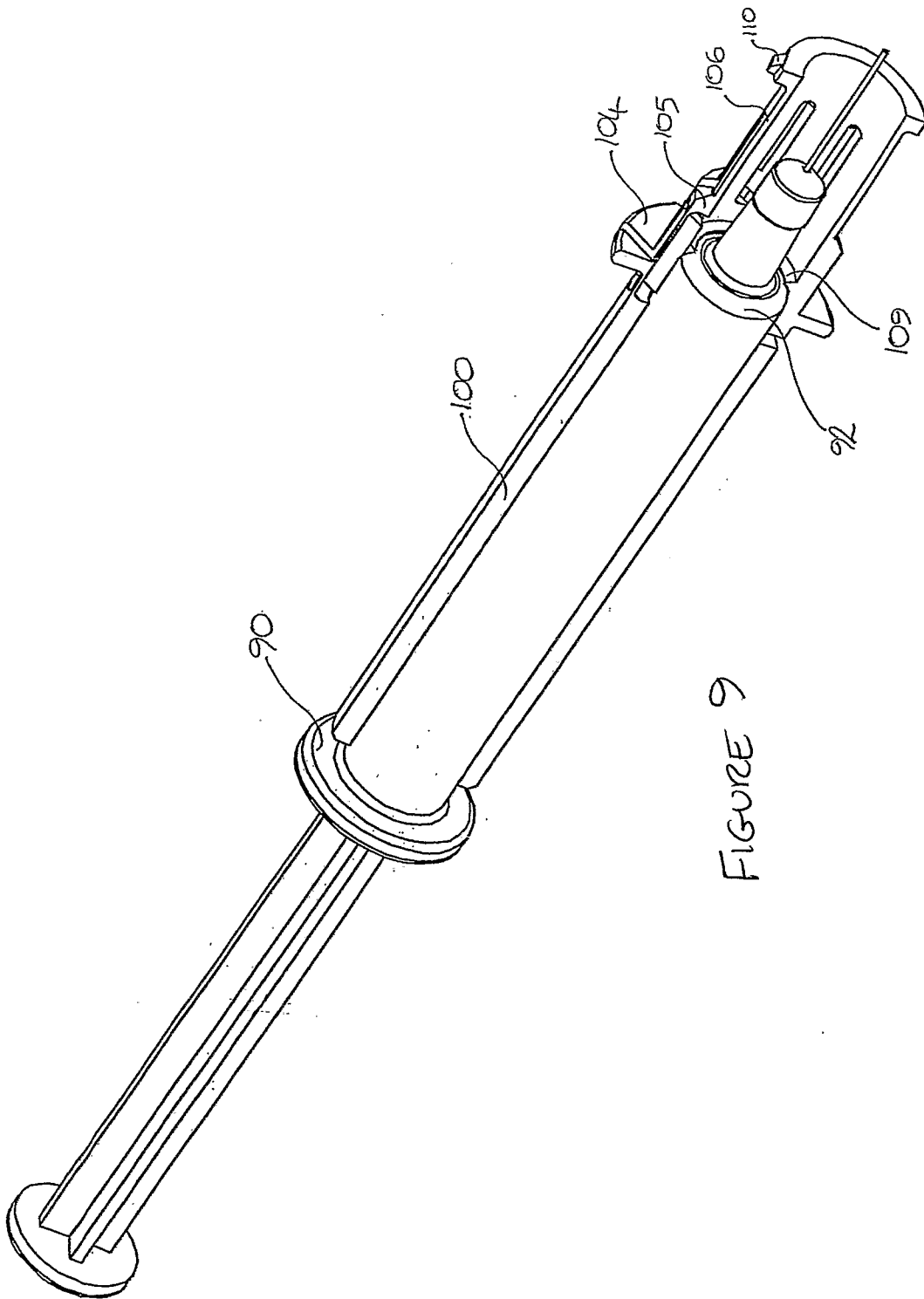

FIGURE 9

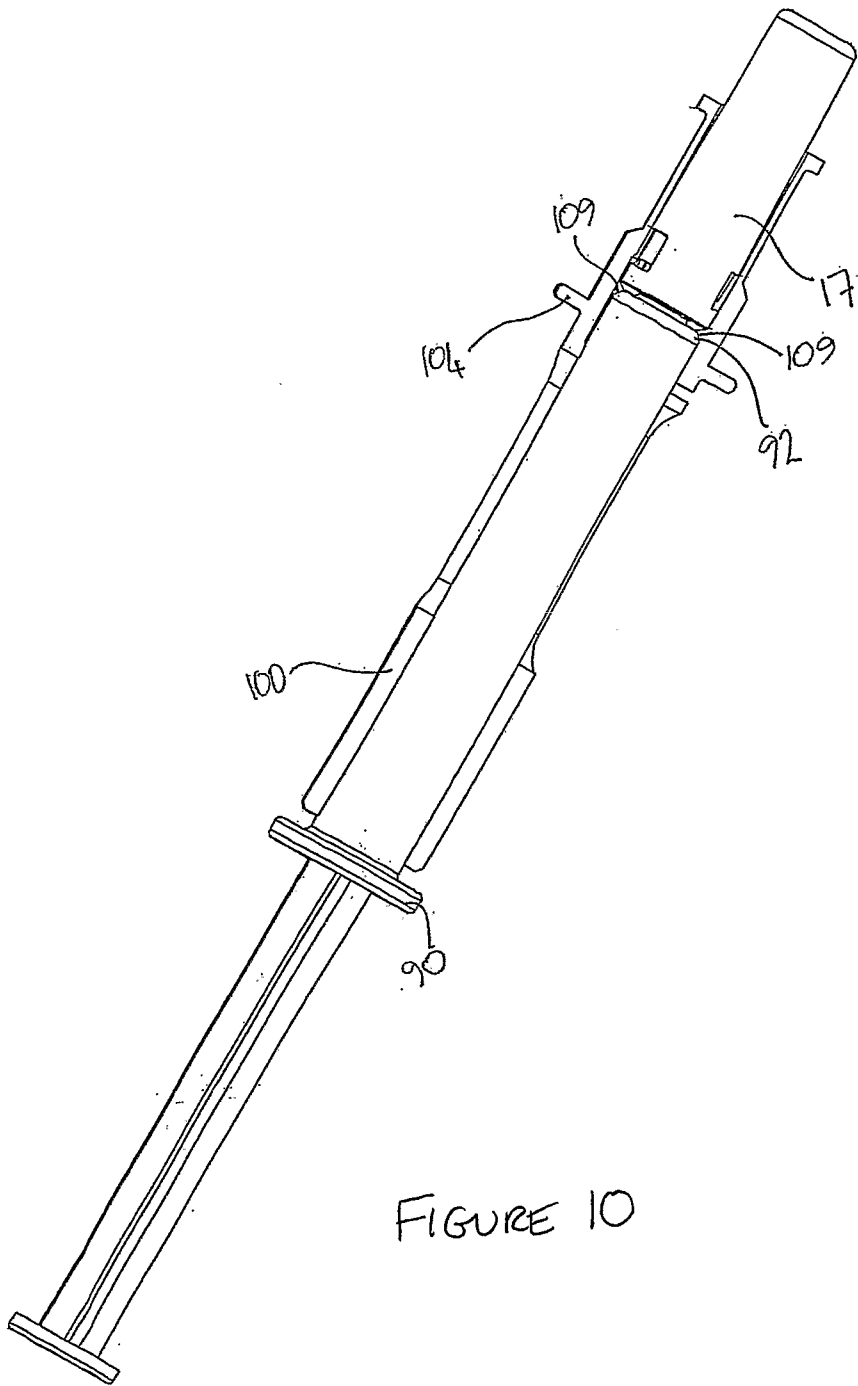

FIGURE 10

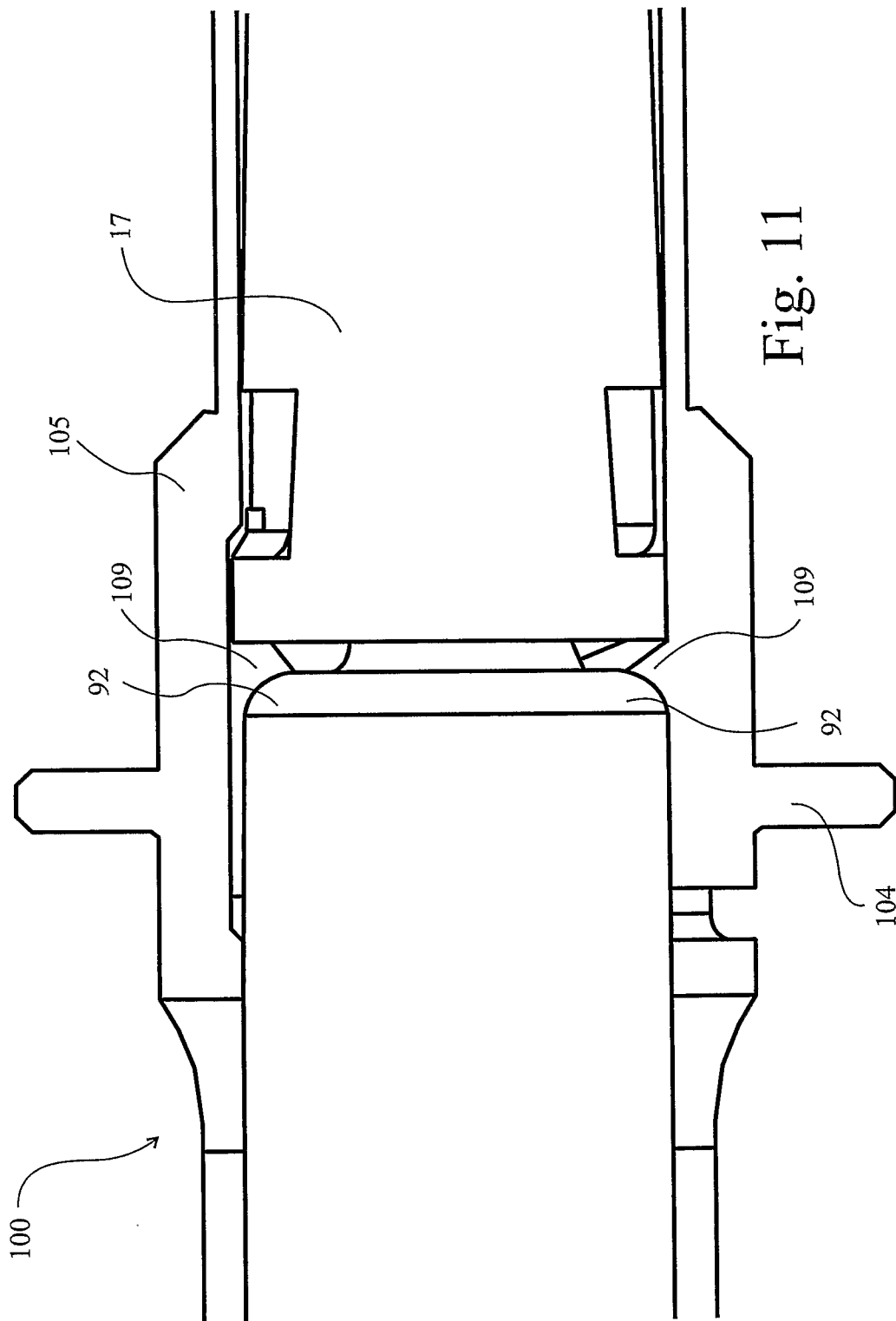

Fig. 11

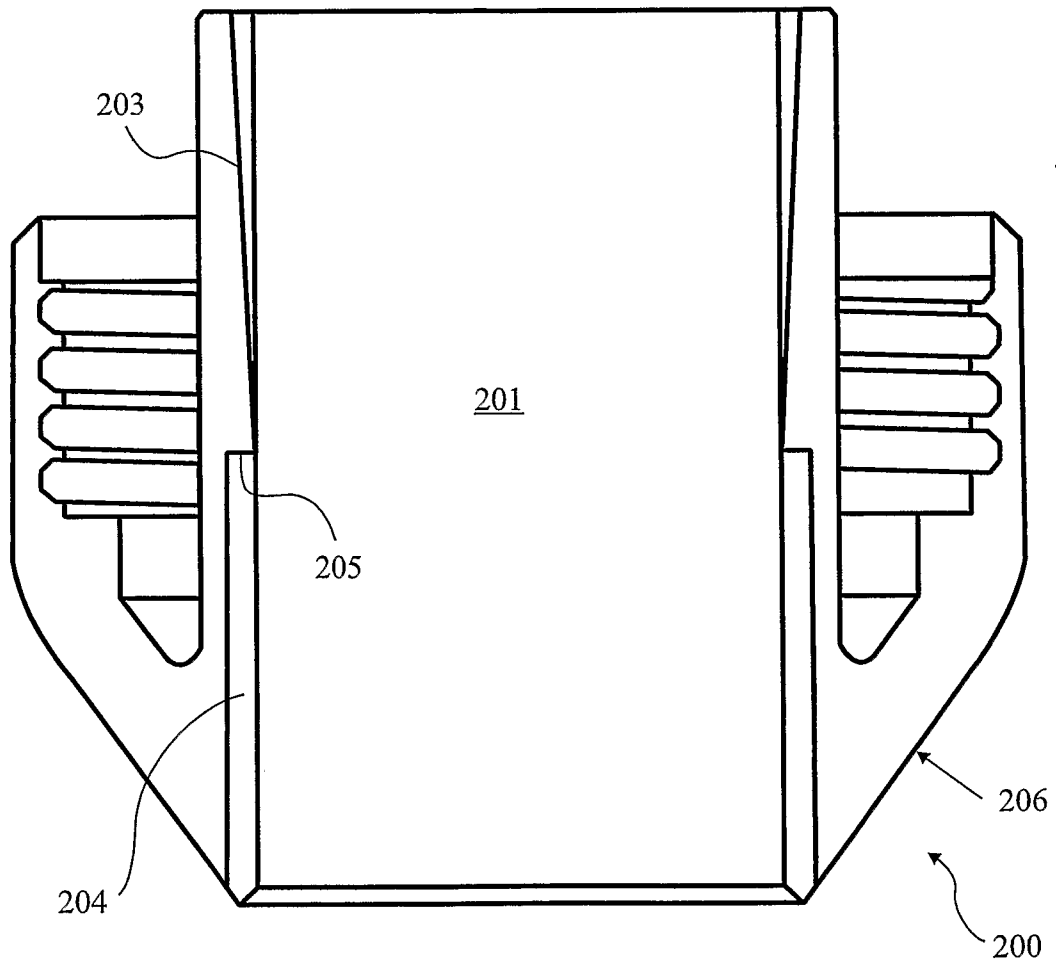

Fig. 12

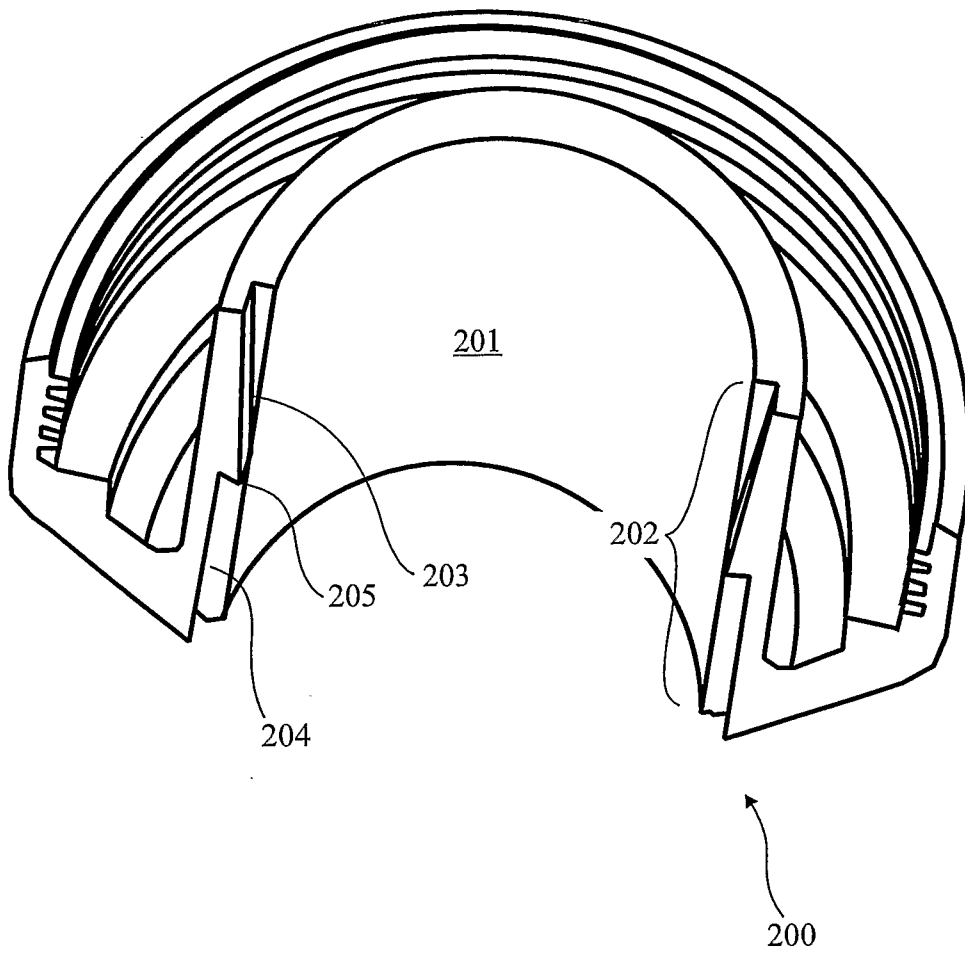

Fig. 13

14/22

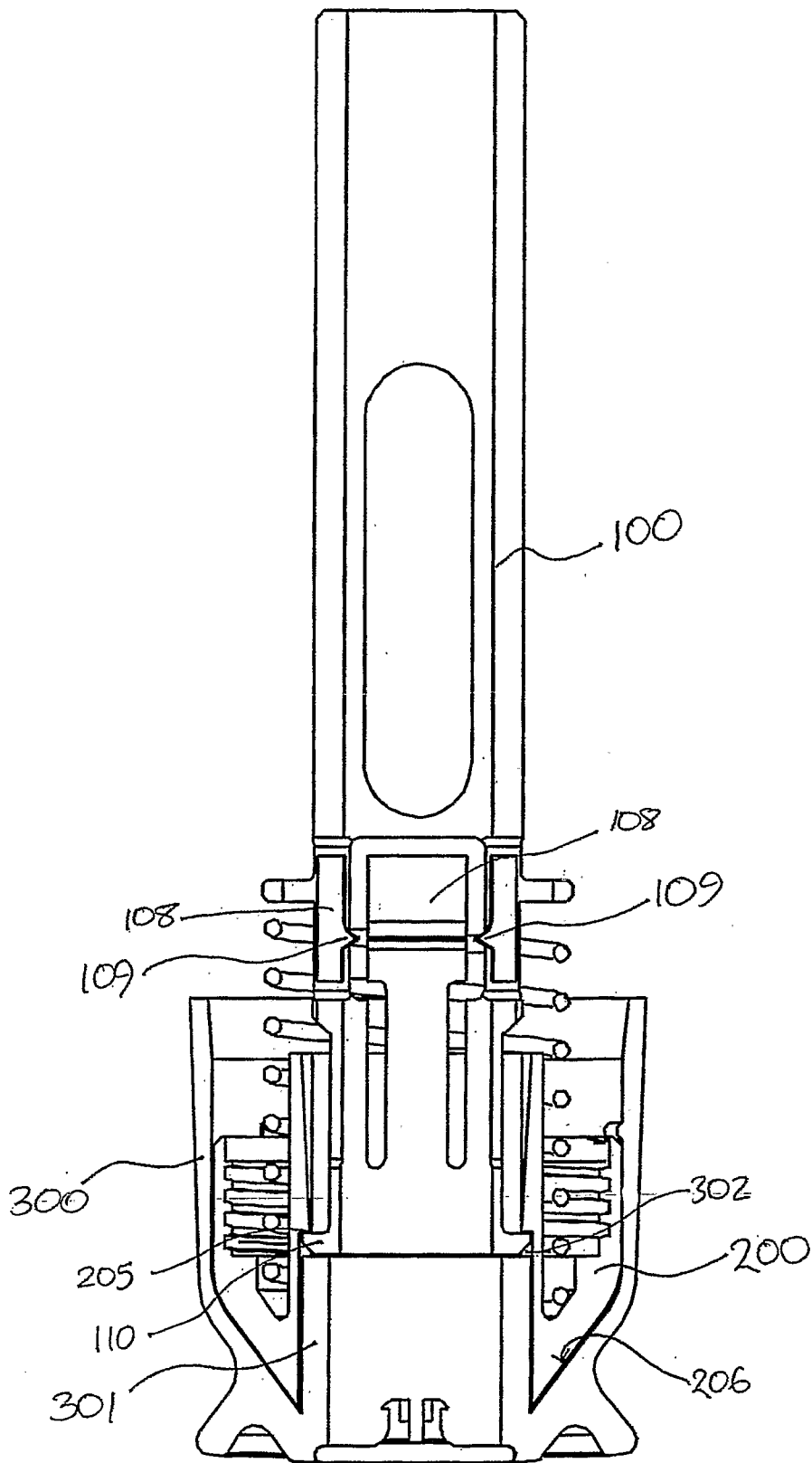

FIGURE 14

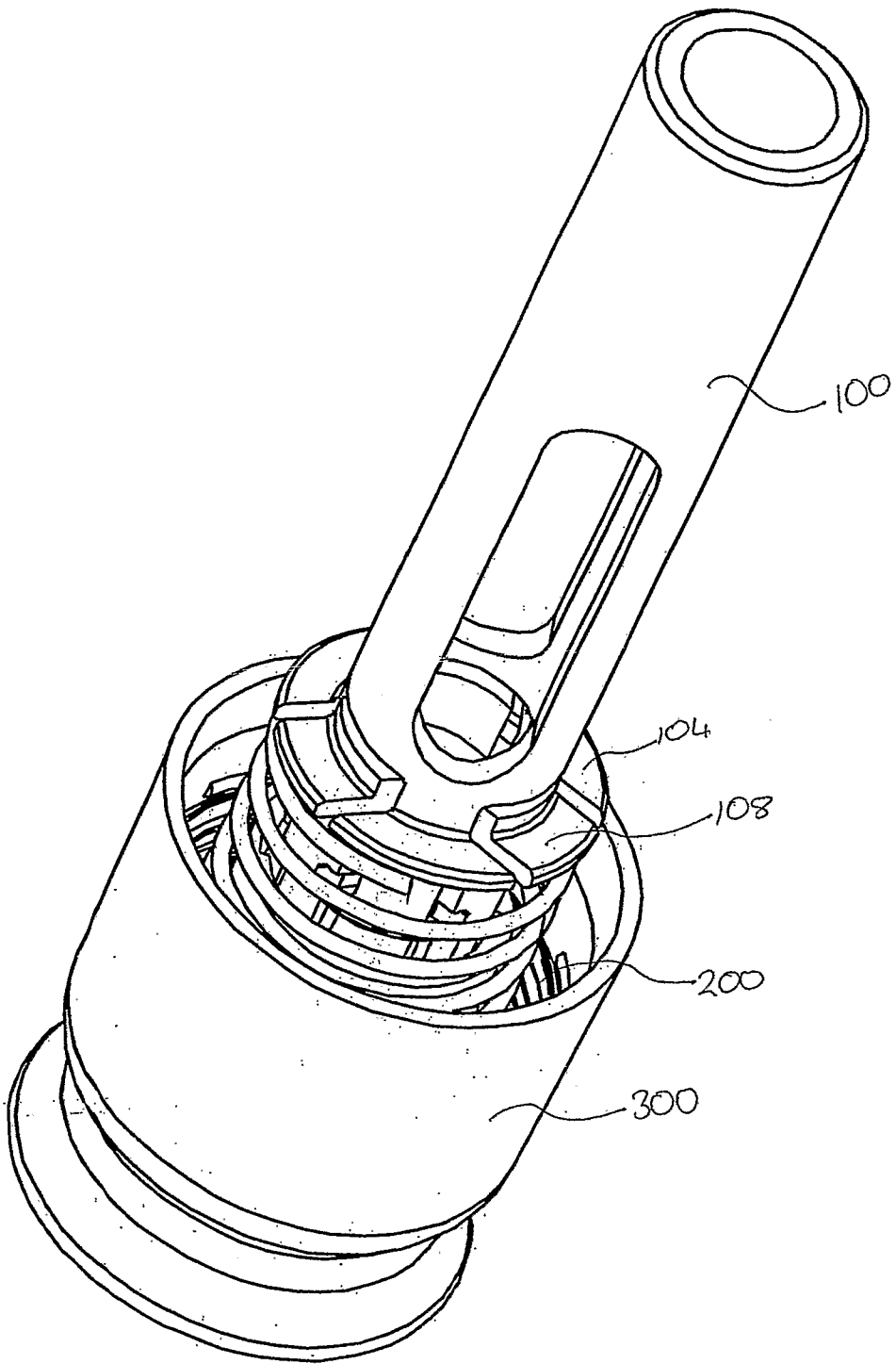

FIGURE 15

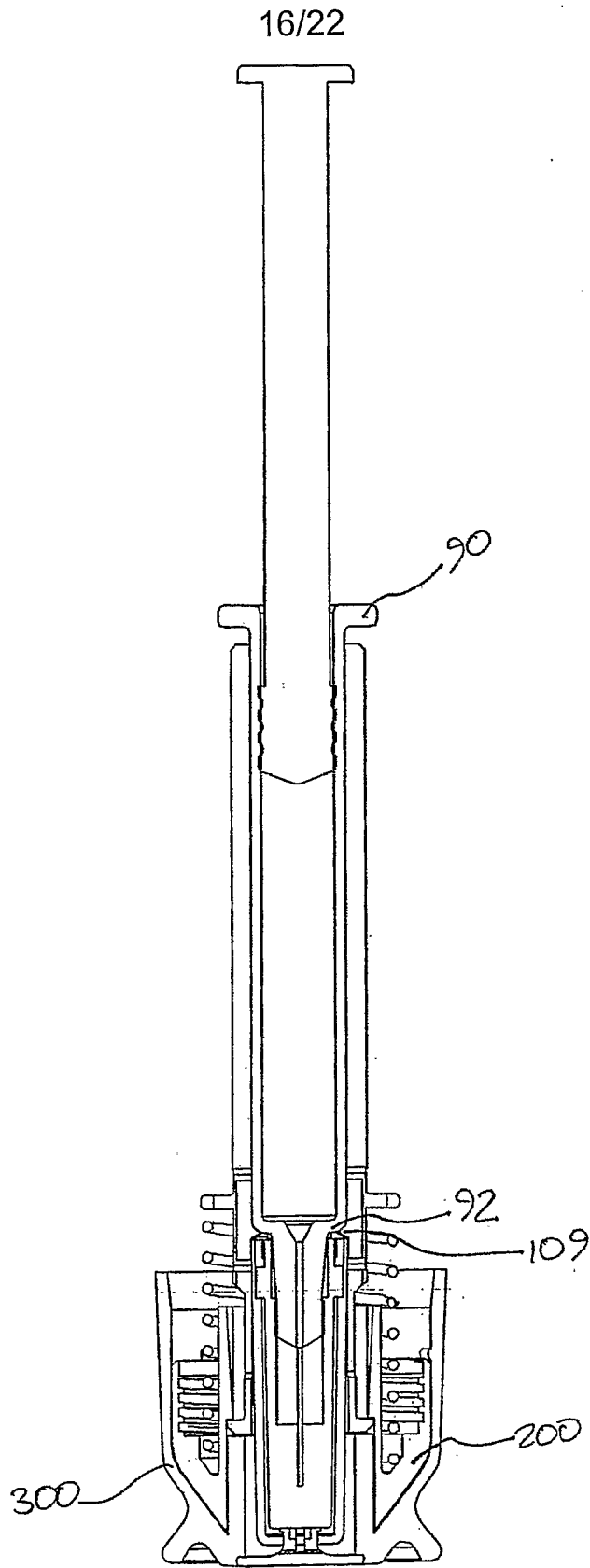
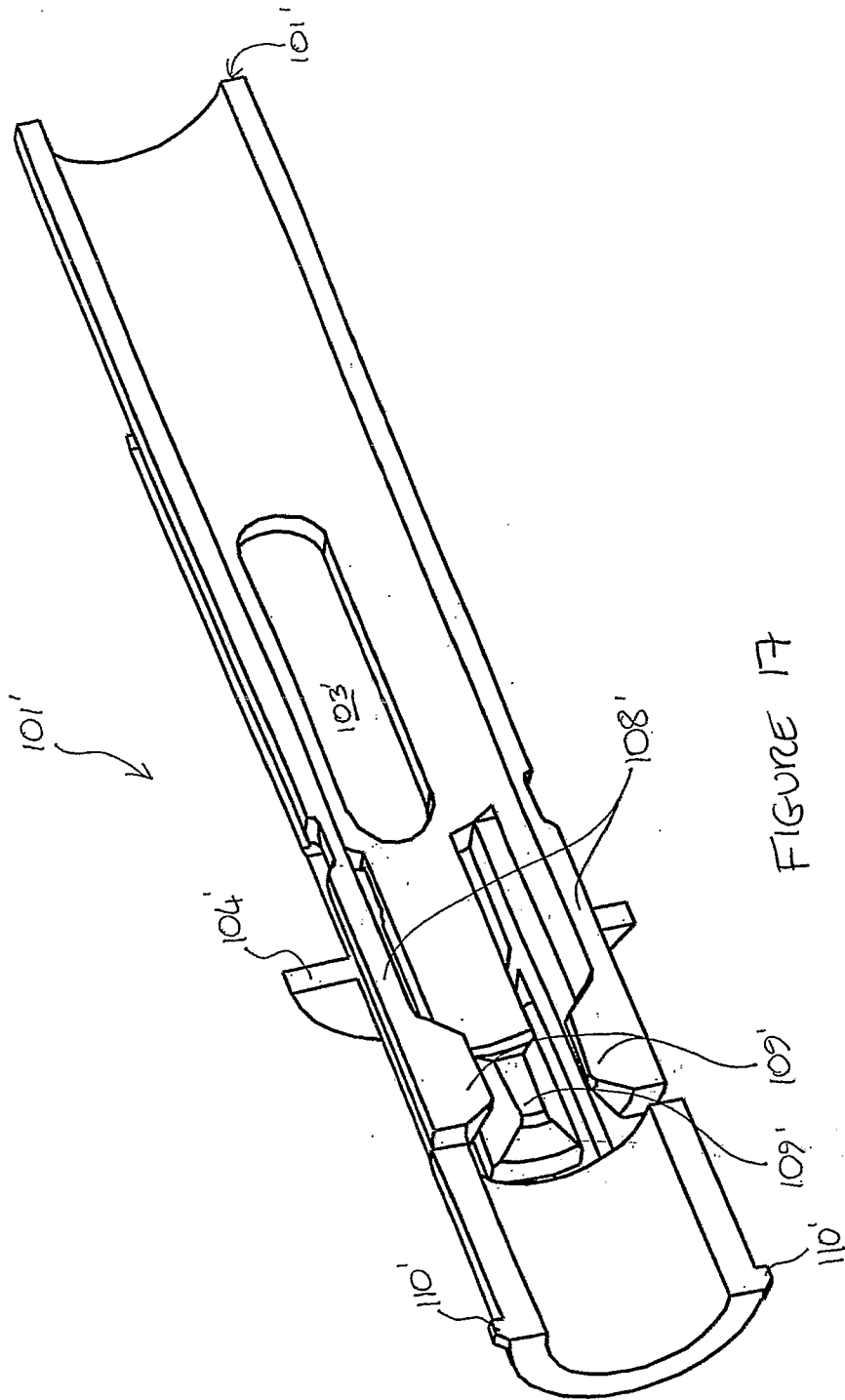
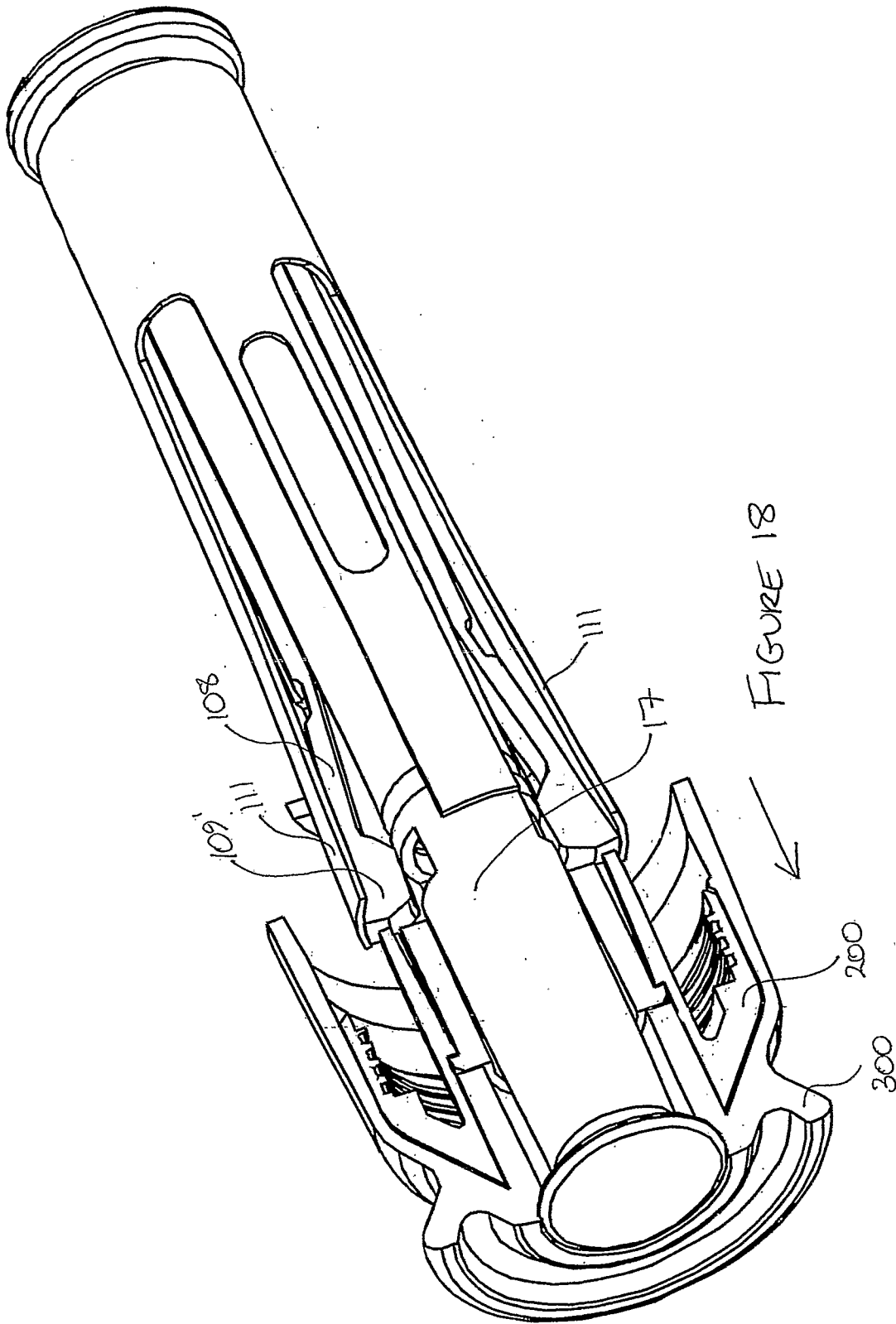

FIGURE 16





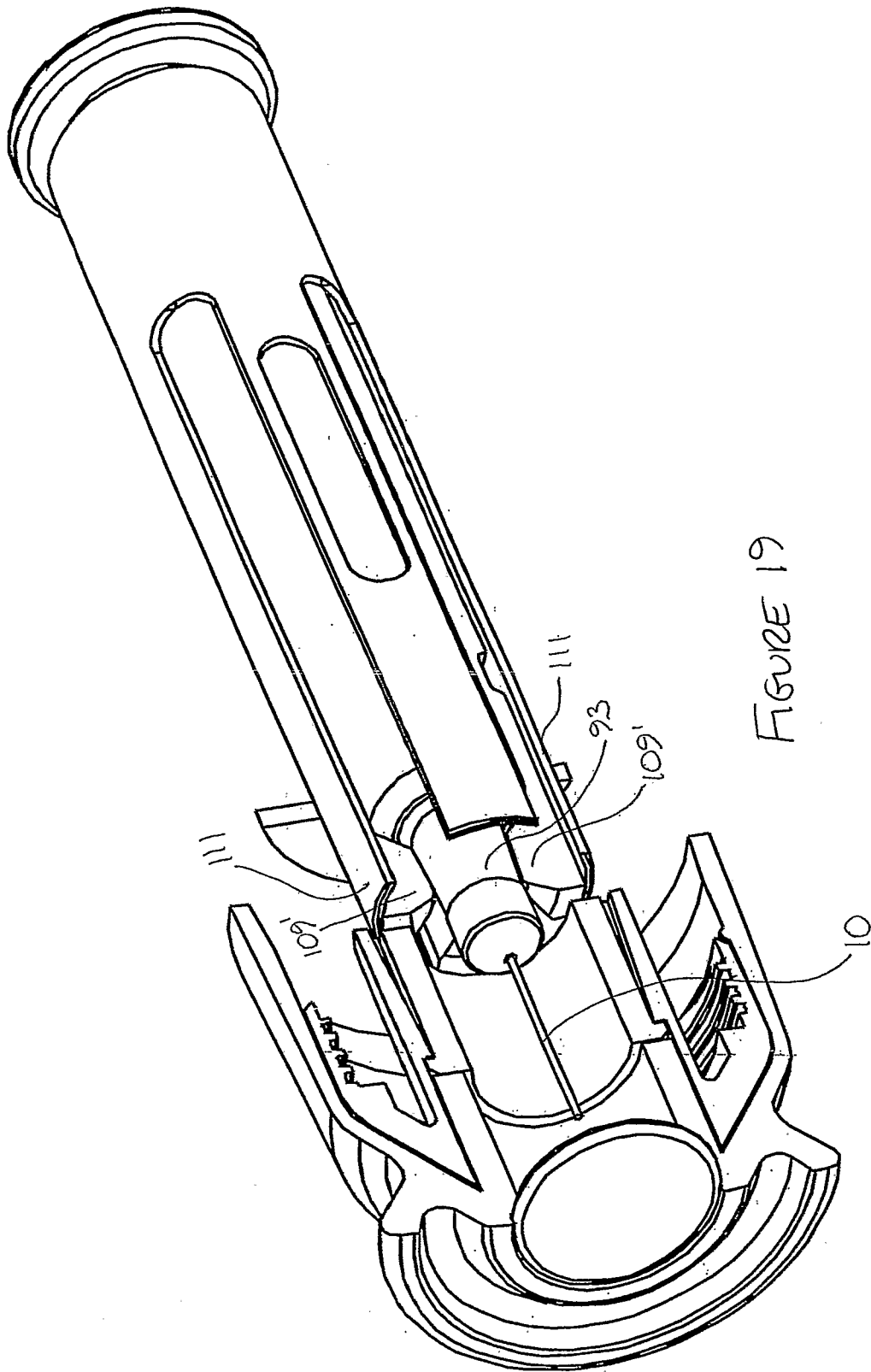

FIGURE 19

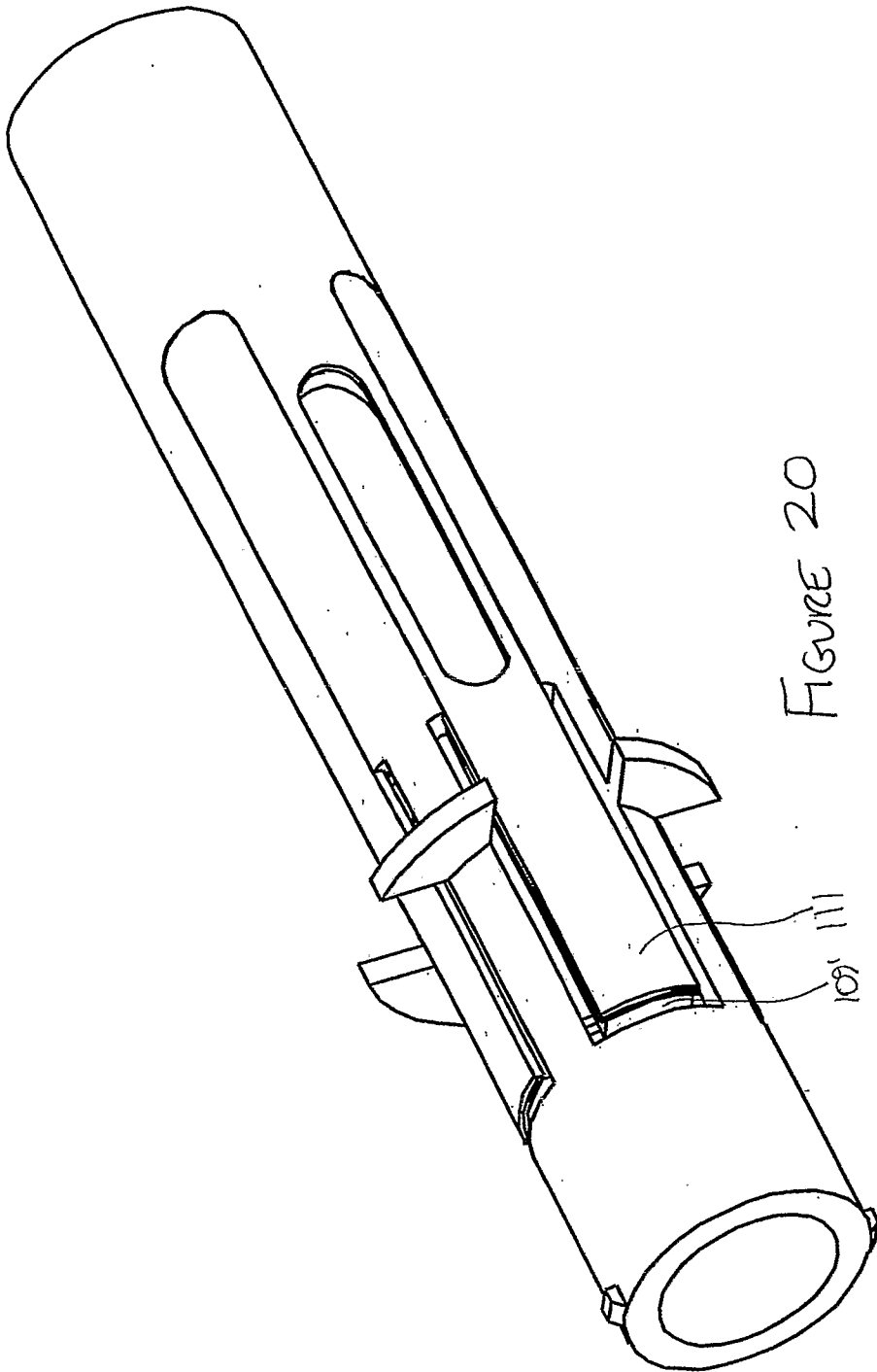

FIGURE 20

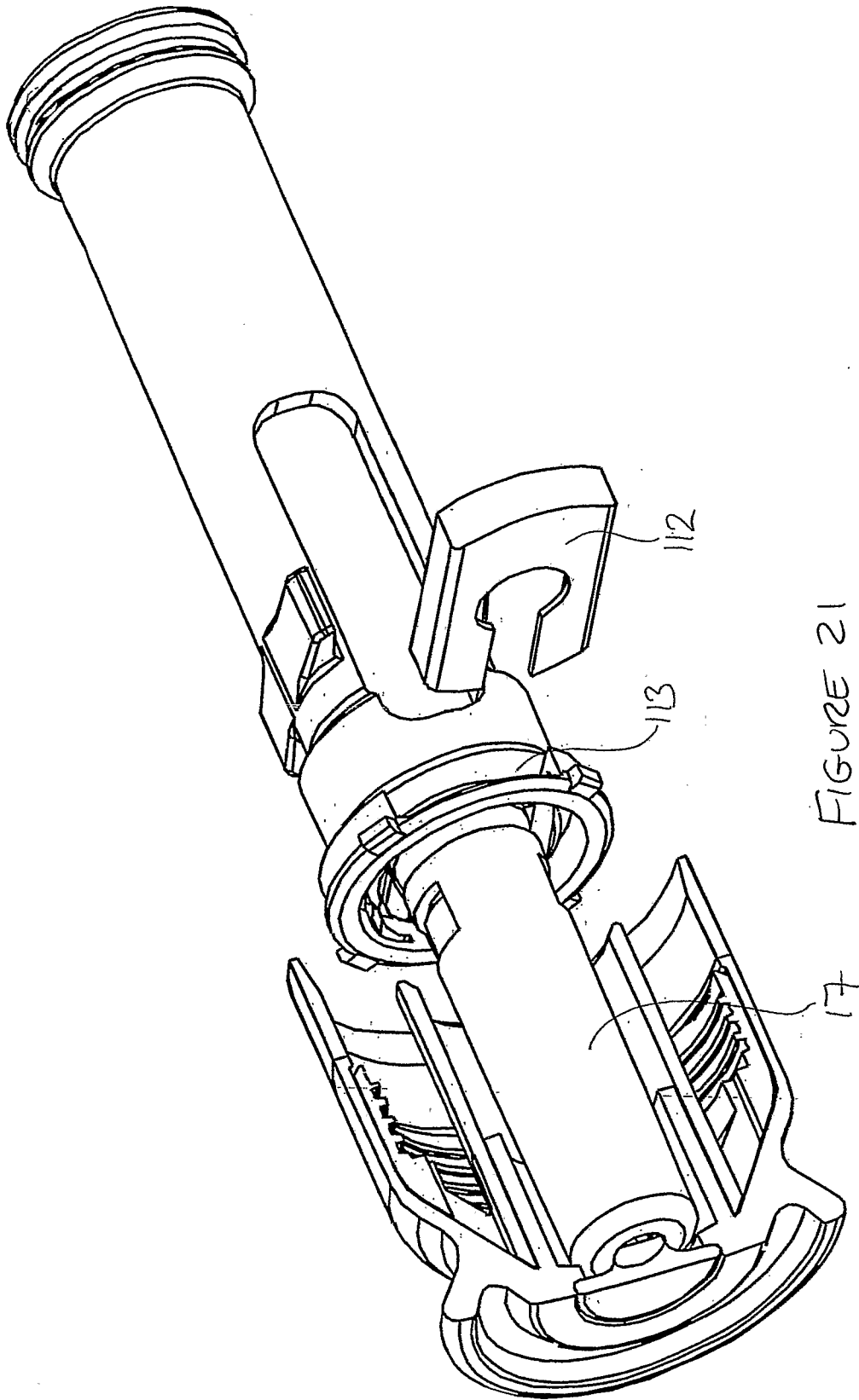

FIGURE 21

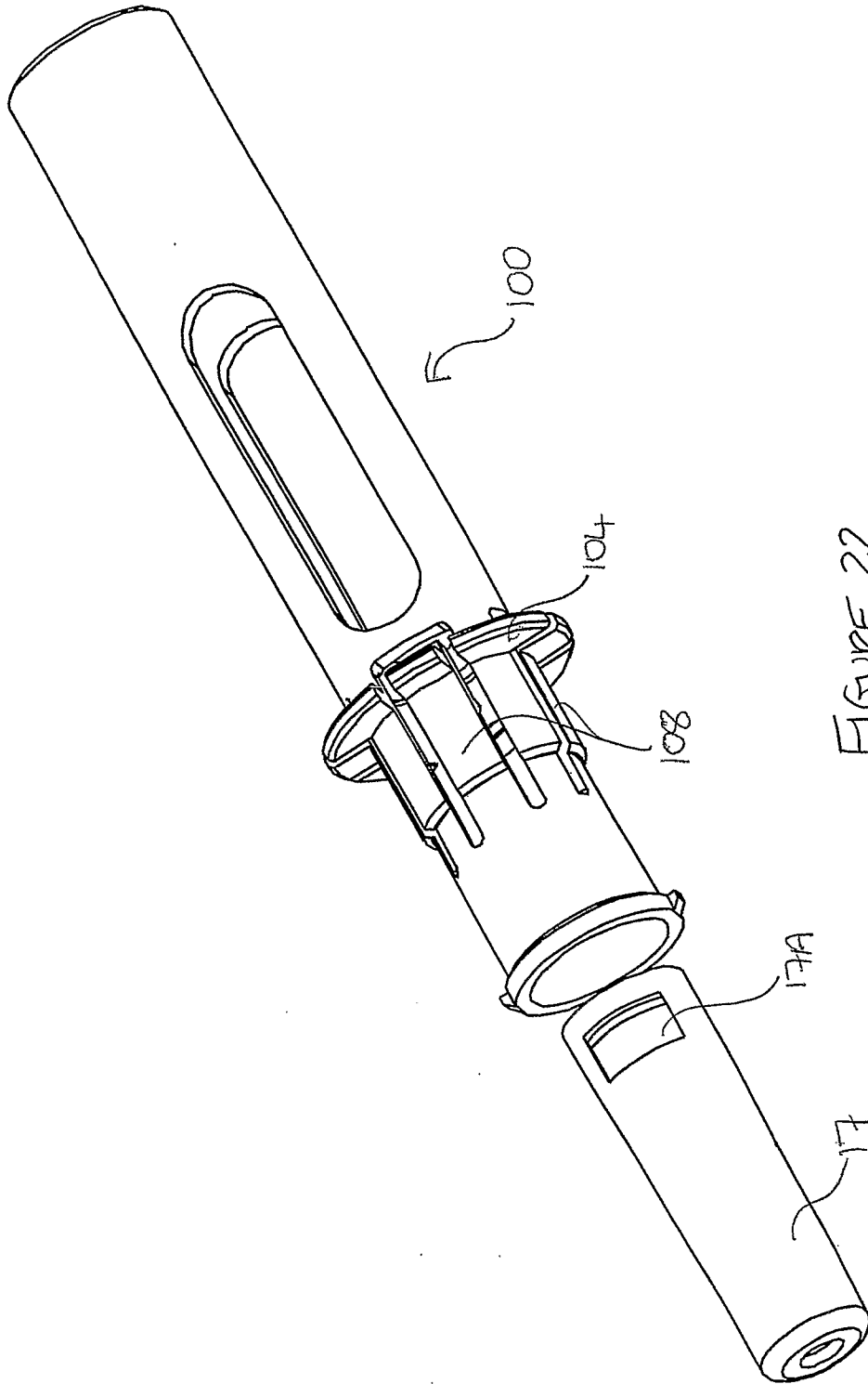

FIGURE 22

INTERNATIONAL SEARCH REPORT

International application No
PCT/GB2007/000141

A. CLASSIFICATION OF SUBJECT MATTER INV. A61M5/20		
According to International Patent Classification (IPC) or to both national classification and IPC		
B. FIELDS SEARCHED		
Minimum documentation searched (classification system followed by classification symbols) A61M		
Documentation searched other than minimum documentation to the extent that such documents are included in the fields searched		
Electronic data base consulted during the international search (name of data base and, where practical, search terms used) EPO-Internal, WPI Data, PAJ		
C. DOCUMENTS CONSIDERED TO BE RELEVANT		
Category*	Citation of document, with indication, where appropriate, of the relevant passages	Relevant to claim No.
X	WO 2005/115507 A (CILAG AG INTERNAT [CH]; HARRISON NIGEL [GB]) 8 December 2005 (2005-12-08) the whole document	1-41, 43, 44
X	WO 99/22792 A (GRECO ERMANNO [IT]) 14 May 1999 (1999-05-14) the whole document	1-41, 43, 44
X	WO 2005/070481 A (MEDICAL HOUSE PLC [GB]; STAMP KEVIN [GB]) 4 August 2005 (2005-08-04) cited in the application page 12 - page 25; figures 1-27	1-41, 43, 44
X	EP 0 518 416 A (DUPHAR INT RES [NL]) 16 December 1992 (1992-12-16) figures 1-7	1-41, 43, 44
----- -/--		
<input checked="" type="checkbox"/> Further documents are listed in the continuation of Box C.		
<input checked="" type="checkbox"/> See patent family annex.		
* Special categories of cited documents :		
A document defining the general state of the art which is not considered to be of particular relevance *E* earlier document but published on or after the international filing date *L* document which may throw doubts on priority claim(s) or which is cited to establish the publication date of another citation or other special reason (as specified) *O* document referring to an oral disclosure, use, exhibition or other means *P* document published prior to the international filing date but later than the priority date claimed	*T* later document published after the international filing date or priority date and not in conflict with the application but cited to understand the principle or theory underlying the invention *X* document of particular relevance; the claimed invention cannot be considered novel or cannot be considered to involve an inventive step when the document is taken alone *Y* document of particular relevance; the claimed invention cannot be considered to involve an inventive step when the document is combined with one or more other such documents, such combination being obvious to a person skilled in the art. *&* document member of the same patent family	
Date of the actual completion of the international search	Date of mailing of the international search report	
27 April 2007	07/05/2007	
Name and mailing address of the ISA/ European Patent Office, P.B. 5818 Patentlaan 2 NL - 2280 HV Rijswijk Tel. (+31-70) 340-2040, Tx. 31 651 epo nl, Fax: (+31-70) 340-3016	Authorized officer Björklund, Andreas	

INTERNATIONAL SEARCH REPORT

International application No
PCT/GB2007/000141

C(Continuation). DOCUMENTS CONSIDERED TO BE RELEVANT

Category*	Citation of document, with indication, where appropriate, of the relevant passages	Relevant to claim No.
A	GB 2 410 188 A (MEDICAL HOUSE PLC THE [GB] MEDICAL HOUSE PLC [GB]) 27 July 2005 (2005-07-27) page 8 - page 12; figures 1-12 -----	
P,X	WO 2006/106295 A (CILAG AG INTERNAT [CH]; BARROW-WILLIAMS TIMOTHY DONALD [GB]; EDINGTON) 12 October 2006 (2006-10-12) the whole document -----	1-41,43, 44
P,X	WO 2006/106291 A (CILAG AG INTERNAT [CH]; JENNINGS DOUGLAS IVAN [GB]) 12 October 2006 (2006-10-12) the whole document -----	1-41,43, 44

FURTHER INFORMATION CONTINUED FROM PCT/ISA/ 210

Continuation of Box II.2

Claims Nos.: 42,45

The claims 42 and 45 contain no features, but mere references to the drawings, and are therefore not possible to search.

The applicant's attention is drawn to the fact that claims relating to inventions in respect of which no international search report has been established need not be the subject of an international preliminary examination (Rule 66.1(e) PCT). The applicant is advised that the EPO policy when acting as an International Preliminary Examining Authority is normally not to carry out a preliminary examination on matter which has not been searched. This is the case irrespective of whether or not the claims are amended following receipt of the search report or during any Chapter II procedure. If the application proceeds into the regional phase before the EPO, the applicant is reminded that a search may be carried out during examination before the EPO (see EPO Guideline C-VI, 8.5), should the problems which led to the Article 17(2) declaration be overcome.

INTERNATIONAL SEARCH REPORT

International application No.
PCT/GB2007/000141

Box II Observations where certain claims were found unsearchable (Continuation of item 2 of first sheet)

This International Search Report has not been established in respect of certain claims under Article 17(2)(a) for the following reasons:

1. Claims Nos.:
because they relate to subject matter not required to be searched by this Authority, namely:

2. Claims Nos.: 42, 45
because they relate to parts of the International Application that do not comply with the prescribed requirements to such an extent that no meaningful International Search can be carried out, specifically:
see FURTHER INFORMATION sheet PCT/ISA/210

3. Claims Nos.:
because they are dependent claims and are not drafted in accordance with the second and third sentences of Rule 6.4(a).

Box III Observations where unity of invention is lacking (Continuation of item 3 of first sheet)

This International Searching Authority found multiple inventions in this international application, as follows:

1. As all required additional search fees were timely paid by the applicant, this International Search Report covers all searchable claims.

2. As all searchable claims could be searched without effort justifying an additional fee, this Authority did not invite payment of any additional fee.

3. As only some of the required additional search fees were timely paid by the applicant, this International Search Report covers only those claims for which fees were paid, specifically claims Nos.:

4. No required additional search fees were timely paid by the applicant. Consequently, this International Search Report is restricted to the invention first mentioned in the claims; it is covered by claims Nos.:

Remark on Protest

- The additional search fees were accompanied by the applicant's protest.
- No protest accompanied the payment of additional search fees.

INTERNATIONAL SEARCH REPORT

International application No
PCT/GB2007/000141

Patent document cited in search report	A	Publication date	AU	Patent family member(s)	Publication date
WO 2005115507	A	08-12-2005	AU	2005247145 A1	08-12-2005
			CA	2568655 A1	08-12-2005
			EP	1755708 A1	28-02-2007
			GB	2414401 A	30-11-2005
WO 9922792	A	14-05-1999	AU	4883797 A	24-05-1999
WO 2005070481	A	04-08-2005	AU	2005205966 A1	04-08-2005
			EP	1715903 A1	02-11-2006
			KR	20060129024 A	14-12-2006
EP 0518416	A	16-12-1992	CA	2070940 A1	14-12-1992
			US	5273544 A	28-12-1993
GB 2410188	A	27-07-2005	CA	2455937 A1	23-07-2005
			CN	1909939 A	07-02-2007
			US	2005165360 A1	28-07-2005
WO 2006106295	A	12-10-2006	GB	2424838 A	11-10-2006
WO 2006106291	A	12-10-2006	GB	2425062 A	18-10-2006