

W. N. REED.
Sink Trap.

No. 109,452.

Patented Nov. 22, 1870.

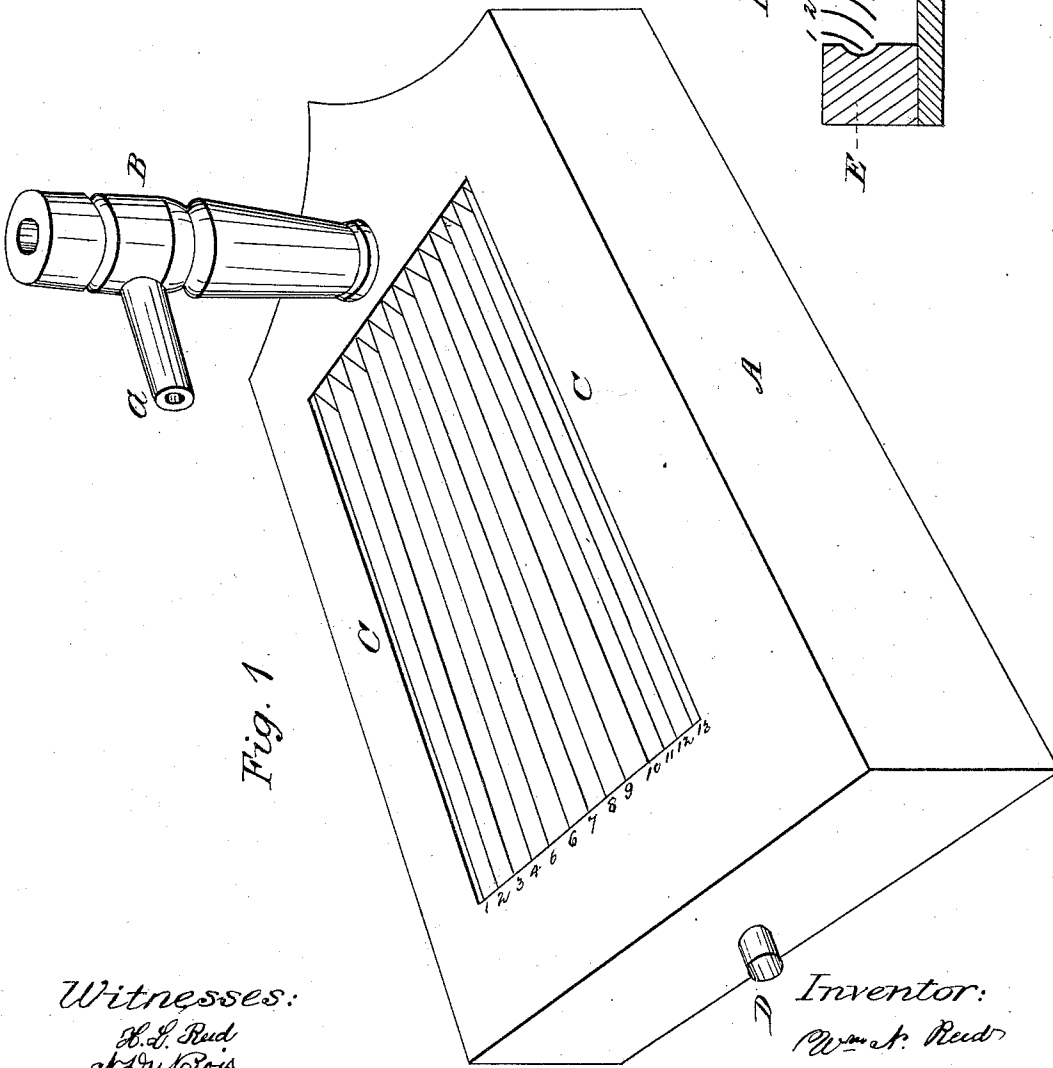

Witnesses:
H. L. Reed
A. D. [Signature]

Inventor:
Wm. N. Reed

United States Patent Office.

WILLIAM N. REED, OF ARLINGTON, VIRGINIA.

Letters Patent No. 109,452, dated November 22, 1870.

IMPROVEMENT IN DRIP-RECEIVING GRATES.

The Schedule referred to in these Letters Patent and making part of the same.

I, WILLIAM N. REED, of Arlington, Alexandria county, Virginia, have invented a certain Machine or Device to be placed under pumps, hydrants, &c., to catch the waste water and prevent splashing, or operate as a strainer, to keep improper substances from getting into the drains, of which the following is a specification.

Nature and Objects of the Invention.

The first part of my invention consists in forming a box or sink of varying size and form, according to circumstances. Across this sink are firmly fixed curved slats or blades with their sharp edges upward, in such a position that the falling water will impinge either upon the edge or slanting sides of the blade, and in either case will glance downward without rebounding, and be caught under the adjoining blade in the bottom of the sink.

Description of the Accompanying Drawing.

Figure 1 is a perspective drawing of a machine embodying my invention.

Figure 2 is a vertical transverse section in the direction C C, showing the ends of the blades laterally curved.

General Description.

A is the frame-work of the combined strainer and shield.

B is the pump, hydrant, or other device from which water or other liquid is discharged.

1 2 3 4 5 6 7 8 9 10 11 12 13 are the blades on which the water falls.

D is a spout to carry off the water from the sink or space below the blades.

E E, fig. 2, are channels cut in the side pieces of the frame, to permit the discharge of all water collected by the blades numbered 1 and 2 and 12 and 13.

F is the bottom of the sink.

G is the discharging-spout of the pump B, from which the water falls upon the blades.

The following are some of the most common circumstances under which my invention may be advantageously used, and the ordinary manner of its working under the spouts of pumps, faucets, hydrants, &c.

Its mode of operation will be readily understood.

When any vessel is filled with water at a pump and then withdrawn, there is always more or less waste water discharged from the spout, which, falling upon a platform, or other nearly level surface, it rebounds, flying off in all directions to a distance proportioned to the height of the fall, splashing and bespattering all persons and things within its reach; in summer causing much dampness and filth, and in winter the accumulation of ice from this source is exceedingly inconvenient, not to say dangerous.

On the contrary, water falling thus upon the shield and strainer finds no surface from which it can be reflected, as the knife-like edges or series of sharp points (for I do not limit my invention to any particular form) do not afford such cause of splashing, as each drop of falling water must, of necessity, strike a point, an edge, or an inclined surface, making too small an angle with the perpendicular to be thrown upward from the shield; consequently, it glances downward between the blades into the bottom of the sink, or into a common sewer; if the former, it escapes at the spout.

Claim.

The curved blades 1 2 3 4 5 6 7 8 9 10 11 12 13, firmly and closely set and braced in the frame A, substantially as set forth.

WM. N. REED.

Witnesses:

T. C. CONNOLLY,
CHAS. H. FOWLER.