



US00D855238S

(12) **United States Design Patent**
Stanley

(10) **Patent No.:** **US D855,238 S**

(45) **Date of Patent:** **** Jul. 30, 2019**

- (54) **BALLAST**
- (71) Applicant: **HGCI, Inc.**, Las Vegas, NV (US)
- (72) Inventor: **John Stanley**, Vancouver, WA (US)
- (73) Assignee: **HGCI, Inc.**, Las Vegas, NV (US)

- 4,394,692 A 7/1983 Randmae
- 4,413,674 A 11/1983 Avery et al.
- 4,471,898 A 9/1984 Parker
- D277,892 S 3/1985 Reding
- 4,602,826 A 7/1986 Zimmer
- D292,619 S 11/1987 Chen

(Continued)

(**) Term: **15 Years**

OTHER PUBLICATIONS

(21) Appl. No.: **29/623,935**

Pro Gear 1000 Watt Magnetic Ballast, image post date 2012, site visited Oct. 16, 2015 (online), <<http://growhop.ie/index.php/pro-gear-1000-watt-magnetic-ballast.html>>.

(Continued)

(22) Filed: **Oct. 27, 2017**

(51) **LOC (11) Cl.** **26-04**

(52) **U.S. Cl.**
USPC **D26/76**

(58) **Field of Classification Search**
USPC D26/76, 78, 79, 80, 81, 82, 83, 85, 86,
D26/88, 90, 93, 111, 113, 118, 119, 120,
D26/121, 122, 138, 139, 140, 141, 142,
D26/152
CPC F21S 2/00; F21S 4/00; F21S 4/003; F21S
4/005; F21S 4/006; F21S 4/007; F21S
4/008; F21S 6/00; F21S 8/00; F21S
8/024; F21S 8/026; F21S 8/031; F21S
8/033; F21S 8/035-037; F21S 8/04; F21S
8/043; F21S 8/063

See application file for complete search history.

Primary Examiner — Natasha Vujcic
(74) *Attorney, Agent, or Firm* — J. Douglas Wells

(57) **CLAIM**

The ornamental design for a ballast, as shown and described.

DESCRIPTION

FIG. 1 is a perspective view of a ballast, as viewed from below, showing my new design;
FIG. 2 is a perspective view of the ballast shown in FIG. 1, as viewed from above;
FIG. 3 is a left side view of the ballast shown in FIG. 1;
FIG. 4 is a right side view of the ballast shown in FIG. 1;
FIG. 5 is a front elevation view of the ballast shown in FIG. 1;
FIG. 6 is a rear elevation view of the ballast shown in FIG. 1;
FIG. 7 is a top plan view of the ballast shown in FIG. 1; and,
FIG. 8 is a bottom plan view of the ballast shown in FIG. 1.
The broken-line disclosure shown in the views is understood to represent portions of the article in which the claimed design is embodied, but which form no part of the claimed design.

(56) **References Cited**

U.S. PATENT DOCUMENTS

- D123,768 S 12/1940 Scribner
- D177,532 S 4/1956 Meyer et al.
- 2,887,242 A 5/1959 Suarez Grau
- D201,083 S 5/1965 Pam
- 3,197,545 A 7/1965 Moore
- D213,580 S 3/1969 Osborne
- 3,741,292 A 6/1973 Aakalu et al.
- 3,829,677 A 8/1974 DeLlano
- 4,078,169 A 3/1978 Armstrong
- 4,214,797 A 7/1980 Borresen

1 Claim, 5 Drawing Sheets

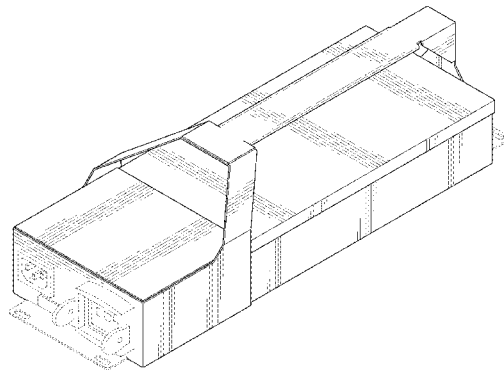

(56)

References Cited

U.S. PATENT DOCUMENTS

D292,913	S	11/1987	Shaper		D619,276	S	7/2010	Choi	
4,745,966	A	5/1988	Avery		7,782,605	B2	8/2010	Wu	
D301,278	S *	5/1989	Hughes	D26/78	D625,168	S	10/2010	Chen	
D306,773	S *	3/1990	Roulstone	D26/78	D625,877	S	10/2010	Hsu	
4,924,152	A	5/1990	Flickinger		D627,503	S	11/2010	Postelmans	
5,031,070	A	7/1991	Hsu		D627,919	S	11/2010	Trice	
5,140,225	A	8/1992	Barton		D638,307	S	5/2011	Rossi	
5,159,528	A	10/1992	Murphy		D638,567	S *	5/2011	Bobel	D26/79
D339,324	S	9/1993	Ahn		D639,495	S	6/2011	Huang	
5,260,851	A	11/1993	Chiou		D643,964	S	8/2011	Heyrman	
5,278,351	A	1/1994	Herrick		D654,021	S	2/2012	Sweeney	
5,309,315	A	5/1994	Naedel		D654,350	S	2/2012	Preda	
D348,869	S	7/1994	Egger		D663,228	S	7/2012	Reinbach	
D360,047	S	7/1995	Zimmerman		D663,459	S	7/2012	Wauters	
5,446,617	A	8/1995	Blocher et al.		D663,469	S	7/2012	Lee	
5,483,423	A	1/1996	Lewis		8,238,117	B2	8/2012	Burwell	
D373,625	S	9/1996	Pereira		D668,810	S	10/2012	Bryant	
D387,333	S	12/1997	Pellow et al.		D673,720	S	1/2013	Bailey	
D387,970	S	12/1997	Enslin		D678,599	S	3/2013	Boyer	
5,867,369	A	2/1999	Antonuccio		D691,074	S	10/2013	Dugardin	
5,874,788	A	2/1999	McCarthy		D692,827	S	11/2013	Chen	
5,894,884	A	4/1999	Durian		D696,165	S	12/2013	Campbell	
D409,139	S	5/1999	Cornell		D697,652	S *	1/2014	Savani	D26/76
5,917,696	A	6/1999	Peng		D698,074	S	1/2014	Hargreaves	
5,944,210	A	8/1999	Yetter		D699,884	S *	2/2014	Savani	D26/76
D413,567	S	9/1999	Person		D704,375	S	5/2014	Bailey	
6,005,768	A	12/1999	Jo		D705,230	S	5/2014	Hung	
6,038,126	A	3/2000	Weng		D709,448	S	7/2014	Zhang	
D425,462	S	5/2000	Ujii		D710,000	S	7/2014	Moreno	
D427,147	S	6/2000	Wei		D710,528	S	8/2014	Wardenburg	
D427,969	S	7/2000	Wei		D710,530	S	8/2014	Chang	
6,082,842	A	7/2000	Ho		D711,818	S	8/2014	Maki	
D432,639	S	10/2000	Durian		D714,253	S	9/2014	Aglassinger	
6,129,429	A	10/2000	Hardt		D715,148	S	10/2014	Kuo	
6,147,859	A	11/2000	Abboud		D715,476	S	10/2014	Tien	
D437,288	S	2/2001	Light		D716,730	S	11/2014	Liu	
6,411,514	B1	6/2002	Hussaini		D724,257	S	3/2015	Klus	
6,445,663	B1	9/2002	Chen		D725,820	S	3/2015	Hargreaves	
6,548,948	B1	4/2003	Muessli		D727,846	S	4/2015	Wen	
D477,568	S	7/2003	Milby		D731,688	S	6/2015	Piano	
6,595,662	B2	7/2003	Wardenburg		D739,347	S	9/2015	Huang	
D478,547	S	8/2003	Milby		D743,890	S	11/2015	Liu	
D483,329	S	12/2003	Kuo		D747,029	S	1/2016	Reynolds	
6,679,619	B2	1/2004	Saieva		D752,803	S	3/2016	Reyes	
6,693,371	B2	2/2004	Ziegler		D757,344	S	5/2016	Reynolds	
6,697,258	B1	2/2004	Muhlfeld		D761,481	S	7/2016	Reynolds	
6,758,353	B2	7/2004	Orr		D797,344	S *	9/2017	Yorio	D26/78
D505,915	S	6/2005	Hussaini		D797,351	S *	9/2017	Stanley	D26/118
D510,320	S	10/2005	Tuomola		D818,626	S *	5/2018	Park	D26/76
6,960,842	B2	11/2005	Ziegler		D822,883	S *	7/2018	Stanley	D26/118
7,040,491	B1	5/2006	Claprood		D825,827	S *	8/2018	Stanley	D26/118
D523,803	S	6/2006	Smith et al.		D831,265	S *	10/2018	Stanley	D26/118
D524,245	S	7/2006	Carson		D833,665	S *	11/2018	Lewis, Jr.	D26/78
7,083,309	B2	8/2006	Chan		D837,442	S *	1/2019	Reynolds	D26/118
D534,119	S	12/2006	Miller		2008/0251663	A1	10/2008	Tracy	
7,164,581	B2	1/2007	Carullo		2010/0319953	A1	12/2010	Yochum et al.	
D537,777	S	3/2007	Hargreaves		2011/0025797	A1	2/2011	Rosati et al.	
D542,460	S	5/2007	Hargreaves		2011/0025803	A1	2/2011	Rosati	
D545,737	S	7/2007	Sherman						
D545,996	S	7/2007	Hargreaves						
D550,894	S	9/2007	Huang						
D554,062	S	10/2007	Ohmi						
7,397,670	B2	7/2008	Su						
7,524,090	B2	4/2009	Hargreaves						
7,566,104	B2	7/2009	Chen						
7,696,872	B2	4/2010	Burwell						
D615,848	S	5/2010	Prichard et al.						

OTHER PUBLICATIONS

Hot Head 1000 Watt Ballast, image post date Jun. 7, 2014, site visited Oct. 16, 2015, (online), <<http://tineye.com/search/16ab65f3e8fc49af5495f0d8aed1735afa6524e/?pluginver=>>>.
 1000 W Hardcore Ballast—Yield Master 6 in Air-cooled Bundle, image post date Jun. 9, 2014, site visited Oct. 16, 2015, (online), <<http://web.archive.org/web/20140609182241/http://4hydroponics.com/sunlight-supply>>.

* cited by examiner

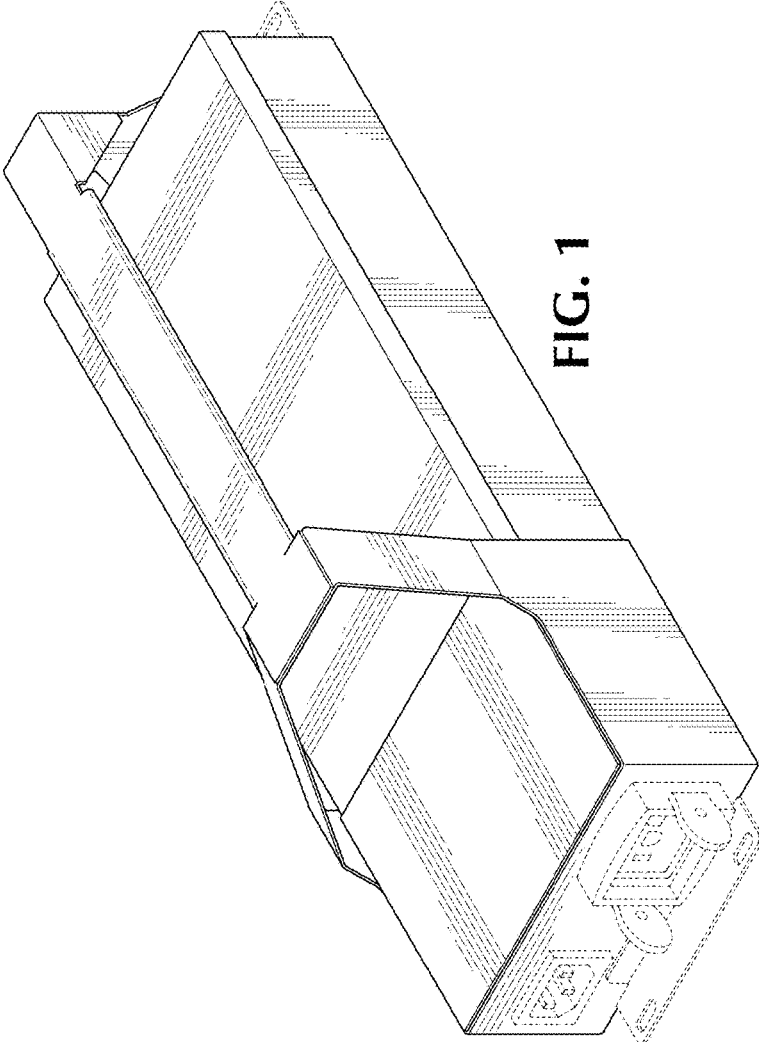

FIG. 1

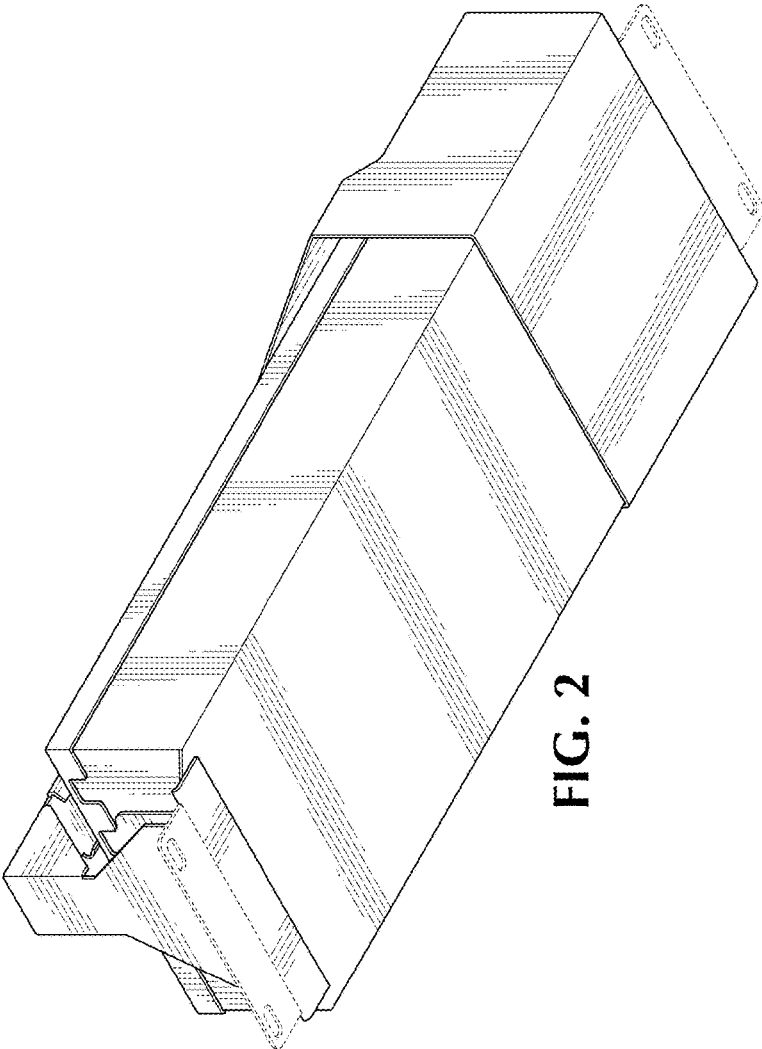

FIG. 2

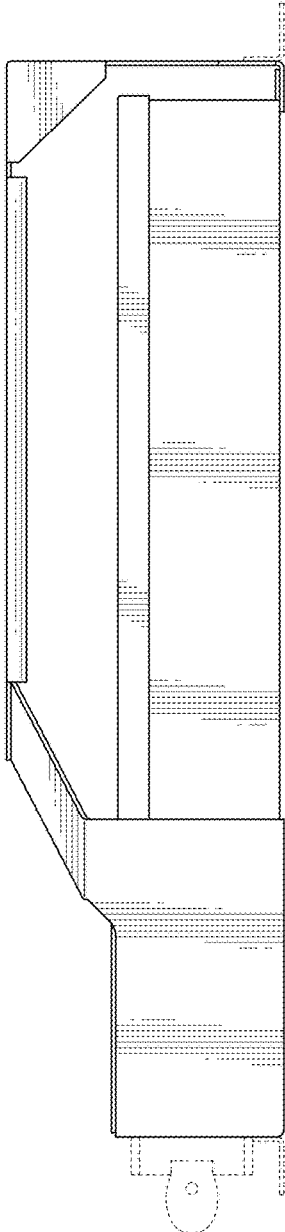

FIG. 3

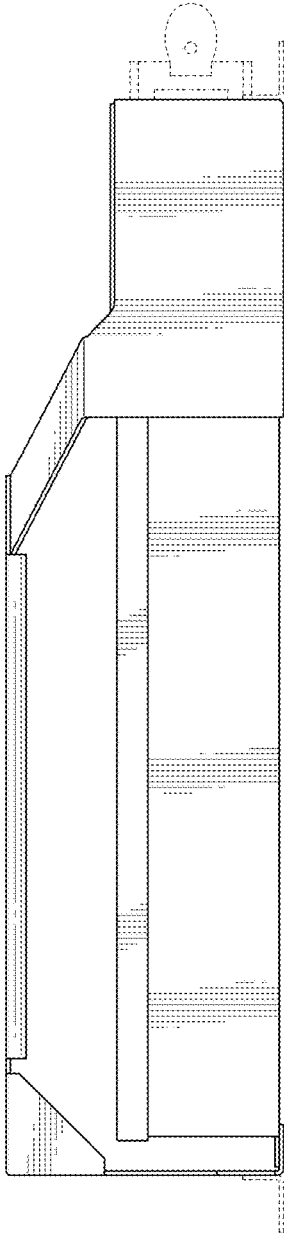

FIG. 4

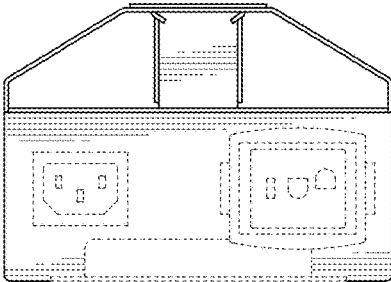

FIG. 5

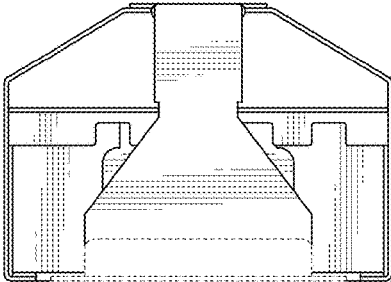

FIG. 6

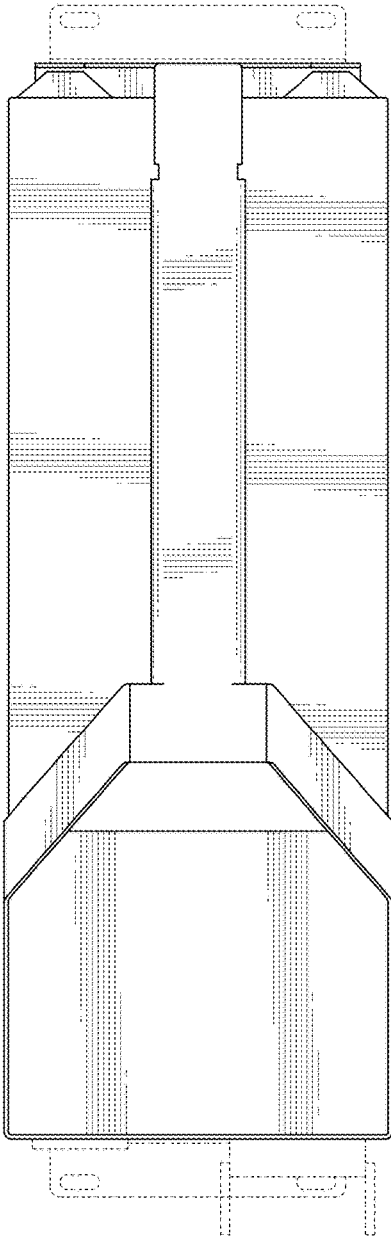

FIG. 7

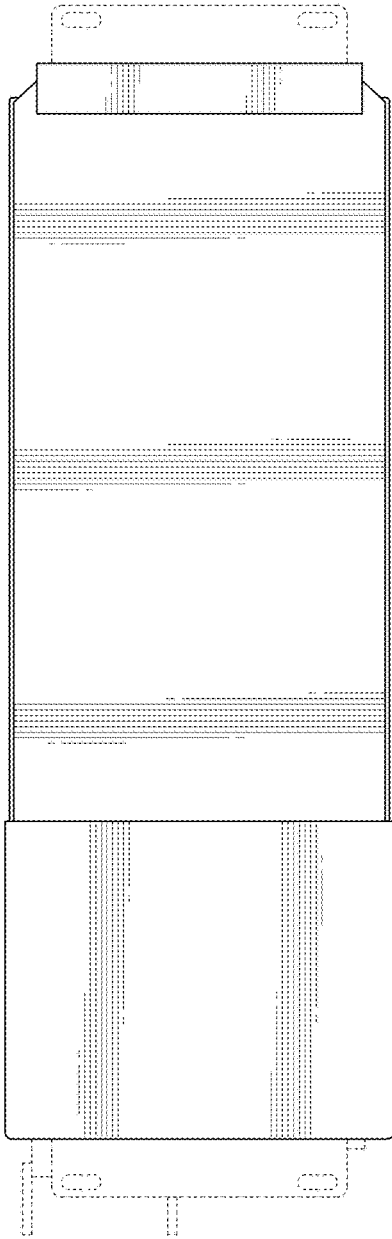

FIG. 8