



INTERNATIONAL APPLICATION PUBLISHED UNDER THE PATENT COOPERATION TREATY (PCT)

<p>(51) International Patent Classification⁶ : B01L 3/14, G01N 15/04, 15/14</p>	<p>A2</p>	<p>(11) International Publication Number: WO 99/46047</p> <p>(43) International Publication Date: 16 September 1999 (16.09.99)</p>
<p>(21) International Application Number: PCT/US99/05511</p> <p>(22) International Filing Date: 9 March 1999 (09.03.99)</p> <p>(30) Priority Data: 60/077,472 10 March 1998 (10.03.98) US</p> <p>(71) Applicant (for all designated States except US): BIOSOURCE PROTEOMICS, INC. [US/US]; 9620 Medical Center Drive, Rockville, MD 20850 (US).</p> <p>(72) Inventors; and (75) Inventors/Applicants (for US only): ANDERSON, Norman, G. [US/US]; 10916 Wickshire Way, Rockville, MD 20852 (US). ANDERSON, N., Leigh [US/US]; 1759 Willard Street, N.W., Washington, DC 20009 (US).</p> <p>(74) Agents: IHNEN, Jeffrey, L. et al.; Rothwell, Figg, Ernst & Kurz, Suite 701 East Tower, 555 13th Street N.W., Columbia Square, Washington, DC 20004 (US).</p>	<p>(81) Designated States: AL, AM, AT, AU, AZ, BA, BB, BG, BR, BY, CA, CH, CN, CU, CZ, DE, DK, EE, ES, FI, GB, GD, GE, GH, GM, HR, HU, ID, IL, IN, IS, JP, KE, KG, KP, KR, KZ, LC, LK, LR, LS, LT, LU, LV, MD, MG, MK, MN, MW, MX, NO, NZ, PL, PT, RO, RU, SD, SE, SG, SI, SK, SL, TJ, TM, TR, TT, UA, UG, US, UZ, VN, YU, ZW, ARIPO patent (GH, GM, KE, LS, MW, SD, SL, SZ, UG, ZW), Eurasian patent (AM, AZ, BY, KG, KZ, MD, RU, TJ, TM), European patent (AT, BE, CH, CY, DE, DK, ES, FI, FR, GB, GR, IE, IT, LU, MC, NL, PT, SE), OAPI patent (BF, BJ, CF, CG, CI, CM, GA, GN, GW, ML, MR, NE, SN, TD, TG).</p> <p>Published <i>Without international search report and to be republished upon receipt of that report.</i></p>	
<p>(54) Title: DETECTION AND CHARACTERIZATION OF MICROORGANISMS</p>		
<p>(57) Abstract</p> <p>A method for separating microorganisms, especially infectious agents, from a mixture by two-dimensional centrifugation on the basis of sedimentation rate and isopycnic banding density, for sedimenting such microorganisms through zones of immobilized reagents to which they are resistant, for detecting banded particles by light scatter or fluorescence using nucleic acid specific dyes, and for recovering the banded particles in very small volumes for characterization by mass spectrometry of viral protein subunits and intact viral particles, and by fluorescence flow cytometric determination of both nucleic acid mass and the masses of fragments produced by restriction enzymes. The method is based on the discovery that individual microorganisms, such as bacterial and viral species, are each physically relatively homogeneous, and are distinguishable in their biophysical properties from other biological particles, and from non-biological particles found in nature. The method is useful for distinguishing infections, for identifying known microorganisms, and for discovering and characterizing new microorganisms. The method provides very rapid identification of microorganisms, and hence allows a rational choice of therapy for identified infectious agents. A particularly useful application is in clinical trials of new antibiotics and antivirals, where it is essential to identify at the outset individuals infected with the targeted infectious agent.</p>		

FOR THE PURPOSES OF INFORMATION ONLY

Codes used to identify States party to the PCT on the front pages of pamphlets publishing international applications under the PCT.

AL	Albania	ES	Spain	LS	Lesotho	SI	Slovenia
AM	Armenia	FI	Finland	LT	Lithuania	SK	Slovakia
AT	Austria	FR	France	LU	Luxembourg	SN	Senegal
AU	Australia	GA	Gabon	LV	Latvia	SZ	Swaziland
AZ	Azerbaijan	GB	United Kingdom	MC	Monaco	TD	Chad
BA	Bosnia and Herzegovina	GE	Georgia	MD	Republic of Moldova	TG	Togo
BB	Barbados	GH	Ghana	MG	Madagascar	TJ	Tajikistan
BE	Belgium	GN	Guinea	MK	The former Yugoslav Republic of Macedonia	TM	Turkmenistan
BF	Burkina Faso	GR	Greece	ML	Mali	TR	Turkey
BG	Bulgaria	HU	Hungary	MN	Mongolia	TT	Trinidad and Tobago
BJ	Benin	IE	Ireland	MR	Mauritania	UA	Ukraine
BR	Brazil	IL	Israel	MW	Malawi	UG	Uganda
BY	Belarus	IS	Iceland	MX	Mexico	US	United States of America
CA	Canada	IT	Italy	NE	Niger	UZ	Uzbekistan
CF	Central African Republic	JP	Japan	NL	Netherlands	VN	Viet Nam
CG	Congo	KE	Kenya	NO	Norway	YU	Yugoslavia
CH	Switzerland	KG	Kyrgyzstan	NZ	New Zealand	ZW	Zimbabwe
CI	Côte d'Ivoire	KP	Democratic People's Republic of Korea	PL	Poland		
CM	Cameroon	KR	Republic of Korea	PT	Portugal		
CN	China	KZ	Kazakstan	RO	Romania		
CU	Cuba	LC	Saint Lucia	RU	Russian Federation		
CZ	Czech Republic	LI	Liechtenstein	SD	Sudan		
DE	Germany	LK	Sri Lanka	SE	Sweden		
DK	Denmark	LR	Liberia	SG	Singapore		
EE	Estonia						

5 TITLE OF THE INVENTION

DETECTION AND CHARACTERIZATION OF MICROORGANISMS

10 BACKGROUND OF THE INVENTION

The present invention relates to the field of separating and identifying microorganisms, particularly infectious agents, using two-dimensional centrifugation and exposure to chemical and enzymatic agents, combined with detection in density gradients based on light scatter or fluorescence, counting by fluorescence flow cytometry, and characterization of intact virions, bacteria, proteins and nucleic acids by mass spectrometry, flow cytometry and epifluorescence microscopy.

The publications and other materials used herein to illuminate the background of the invention or provide additional details respecting the practice, are incorporated by reference, and for convenience are respectively grouped in the appended List of References. Patents referenced herein are also incorporated by reference.

In the prior art, diagnosis of viral and bacterial infections has been done by culturing the causal agents in suitable media or in tissue culture to obtain sufficient particles for analysis, followed by identification based on which conditions support growth, on reaction to specific antibodies, or based on nucleic acid hybridization (Gao and Moore, 1996). Biological growth can be omitted when the polymerase chain reaction (PCR) is used to amplify DNA, however, PCR requires sequence-specific primers, and is thus limited to known or suspected agents (Bai et al., 1997). For all these methods, considerable time is required, and the methods are useful for agents whose properties are known or suspected. Existing methods do not provide means for rapidly isolating and characterizing new infectious agents. Hundreds of infectious agents are known, and it is infeasible to have available reagents for an appreciable fraction of them.

Techniques for recovering infectious agents from blood, urine, and tissues have been previously developed based on centrifugation or filtration, but have not been widely used clinically

(Anderson et al., 1966; Anderson et al., 1967). The highest resolution methods use rate zonal centrifugation to separate fractions based on sedimentation rate (measured in Svedberg units, S) and isopycnic banding density (measured in grams per mL or ρ). S- ρ separations have been used to isolate virus particles in a high state of purity from rat liver homogenates, and have been used to isolate the equivalent of approximately 20 virions per cell (Anderson et al., 1966). In these studies, virus particles were detected by light scattering and visualized by electron microscopy. The separations required complex special equipment not generally available, one or more days of effort, and they did not provide a definitive identification of the bacterial or viral species separated.

It is important to show that candidate infectious particles isolated by centrifugal methods actually contain nucleic acids. DNA and RNA in both active and fixed bacterial and viral particles have been stained with fluorescent dyes specific to nucleic acids, and observed and counted by fluorescent microscopy and flow cytometry. Many dyes are now known which exhibit little fluorescence in the free state, but become highly fluorescent when bound to nucleic acids. Some bind differentially to DNA or RNA or to different specific regions, and some show different emission spectra depending on whether bound to DNA or RNA. In this disclosure, dyes referred to are fluorescent dyes. By differential fluorescence spectroscopy ssDNA, dsDNA and RNA may be distinguished. See, Haugland, 1996; Mayor and Diwan, 1961; Mayor, 1961; Hobbie et al., 1977; Zimmerman, 1977; Perter and Feig, 1980; Paul, 1982; Suttle, 1993; Hiron et al., 1994; Hennes and Suttle, 1995; Hennes et al., 1995.

Isolated nucleic acid molecules of the dimensions found in bacteria and viruses have been counted and their mass estimated using fluorescence flow cytometry for molecules in solution, and epifluorescence microscopy of immobilized molecules (Hennes and Suttle, 1995, Goodwin et al., 1993). In both instances, the size of fragments produced by restriction enzymes can be estimated, and the molecules identified by reference to a database listing the sizes of fragments of known DNA molecules produced by different restriction enzymes (Hammond et al., U.S. Patent No. 5,558,998; Jing et al., 1998).

Using specific fluorescently-labeled antibodies, specific identifications may also be made. These studies are time consuming, and require batteries of specific antibodies, together with epifluorescent microscopy or fluorimeters.

Matrix-Assisted Laser-Desorption-Ionization Time-of-Flight Mass Spectrometry (MALDI-TOF-MS) currently allows precise measurements of the masses of proteins having molecular

weights of over 50,000 daltons. Individual virion proteins have been previously studied by mass spectrometry (Siuzdak, 1998); however, resolution of complete sets of viral subunits from clinically relevant preparations of intact viruses, and the demonstration that precise measurements could be made of their individual masses, have not been previously reported. While single protein mass measurements can reliably identify many proteins, when a set of proteins from a virus or bacterial cell are known, detection of such a set provides more definitive identification. Methods are currently also being developed which allow partial sequencing of proteins or enzymatically produced peptide fragments and thus further increase the reliability of identifications. For MALDI-TOF-MS currently used methods require a picomole or more of protein, while electrospray mass spectrometry currently requires 5-10 femtomoles. The detection limits with mass spectrometry, especially MALDI, depend on getting a sample concentrated and on to a very small target area. Sensitivity will increase as ultramicro methods for concentrating and transferring ever smaller-volume samples are developed. See, Claydon et al., 1996; Fenselau, 1994; Krishnanurthy et al., 1996; Loo et al., 1997; Lennon and Walsh, 1997; Shevchenko et al., 1996; Holland et al., 1996; Liang et al., 1996.

Centrifugal methods for concentrating particles from large into small volumes have been in use for decades. Using microbanding centrifuge tubes which have a large cylindrical volume and cross section which tapers gradually in a centrifugal direction down to a small tubular section, particles may be concentrated or banded in a density gradient restricted to the narrow tubular bottom of the tube, or may be pelleted. The basic design of such tubes are well known by those skilled in the arts. See, Tinkler and Challenger, 1917; Cross, 1928; ASTM Committee D-2, 1951; Davis and Outenreath, U.S. Patent No. 4,624,835; Kimura, U.S. Patent No. 4,861,477; Levine et al., U.S. Patent No. 5,342,790; Saunders et al., U.S. Patent No. 5,422,018; Saunders, U.S. Patent No. 5,489,396. The original tubes of this type were called Sutherland bulbs and were used to determine the water content of petroleum (The Chemistry of Petroleum and Its Substitutes, 1917, ASTM Tentative Method of Test for Water and Sediment by Means of Centrifuge, ASTM Designation: D 96-50T, 1947). Slight modifications of the basic design are described in U.S. Patent Nos. 4,106,907; 4,624,835; 4,861,477; 5,422,018, 5,489,396. Such tubes have been made of glass or plastic materials, and the use of water or other fluids to support glass or plastic centrifuge tubes in metal centrifuge shields has long been well known in the art. However, centrifuge tubes disclosed in the prior art which include a shape similar to that of the microbanding centrifuge tubes of the instant invention could not withstand the centrifugal forces required to band viral particles in

gradients. Conventional centrifuge tubes, or tubes derivative from the Sutherland design have been used for density gradient separations, and for separations in which wax or plastic barriers are used which position themselves between regions of different density to allow recovery of these fractions without mixing. There has been no previous discussion of barriers which prevent mixing of step
5 gradient components at rest, but which barriers are centrifuged away from the gradient during rotation. Nor have tube closures for high-speed thin-walled swinging-bucket centrifuge tubes been described, whose exterior surfaces can be disinfected after the tubes are loaded.

The efficient stabilization of very shallow density gradients in centrifugal fields is well known, and is utilized in analytical ultracentrifugation to cause a sample layer to flow rapidly to the
10 centripetal surface of a gradient without mixing using a synthetic boundary cell (Anderson, U.S. Patent No. 3,519,400). Hence, light physical barrier disks between step gradient components can be moved away from the gradient by centrifugal force without appreciably disturbing the gradient, provided that they are made of porous, woven or sintered materials having a physical density less than that of the sample layer, such as polyethylene or polypropylene.

Many authors have noted that viruses and bacteria are often resistant to the actions of
15 detergents and enzymes which will digest or dissolve contaminating particles of biological origin, and efforts have been made to classify infectious agents on the basis of their differential sensitivities. These differences have not previously and conveniently been incorporated in a method for detecting and quantifying infectious agents. See, Gessler et al., 1956; Theiler, 1957; Epstein and Hold, 1958;
20 Kovacs, 1962; Planterose et al., 1962; Gard and Maaloe, 1959. Density differences between different species of virus and bacteria are well known, but have not been previously exploited for purposes of identification.

Infectious particles exhibit a wide range of isopycnic banding densities ranging from
25 approximately 1.17 g/ml to 1.55 g/ml, depending on the type of nucleic acid present, and the ratios between the amount of nucleic acid, protein, carbohydrate, and lipid present. While such banding density differences are well known, no attempt has been previously made to systematically measure them and use the data to classify infectious agents.

The present invention is directed to an integrated system for concentrating, detecting and
30 characterizing infectious agents using separations based on sedimentation rate and banding density, spectral analysis of emitted fluorescent light to distinguish DNA from RNA, differentiation of viral and bacterial particles from other particles by sedimentation through zones of solubilizing enzymes or reagents, determination of the isopycnic banding densities of infectious particles by reference to

the positions of synthetic density standardization particles, particle detection using fluorescent dyes for DNA or RNA, further concentration of banded particles by pelleting, transfer of concentrated particles to mass spectrometer targets for protein mass determination and analysis, counting of concentrated particles by epifluorescent microscopy and fluorescence flow cytometry, and
5 identification of bacterial or viral nucleic acids by restriction fragment length polymorphism analysis using either immobilized nucleic acid molecules, or ultrasensitive fluorescence flow cytometry. These methods are especially useful in characterizing biological samples which have low titres of virus and which contain viruses which are not culturable.

Furthermore, all current methods used to detect and characterize infectious agents, including
10 use of fluorescent antibodies, detection of agent-associated enzymes, culture to increase agent mass, PCR amplification, restriction fragment length polymorphism analysis, hybridization to probes immobilized on chips, histochemical analysis, and all forms of microscopy including electron microscopy, are vastly improved by preconcentration of the microorganisms using the methods of the present invention.

15 These techniques have not previously been assembled into one operational system capable of routine field, hospital, and clinical laboratory use. The present application describes innovations and inventions which make such a system feasible. For work with potentially lethal agents, the system will be assembled in containment, and at least partially automated.

20 SUMMARY OF THE INVENTION

The overall objective of this invention is to develop a physical system for rapidly identifying infectious disease agents without growing them, and for discovering new infectious agents. The process is based on the thesis that infectious agents constitute a unique group of particles which can be isolated by physical and chemical means from other natural particles and identified by their
25 physical parameters using centrifugal means, fluorescence, and mass spectrometry. The system will allow rapid clinical distinction between viral and bacterial infections, identification of specific agents with the aim of providing specific therapy, and the rapid discovery of new infectious agents. In addition the system will make it feasible to develop and test new antibiotics and antiviral agents in man by measuring the effects of these agents on bacterial and viral loads. At present the
30 development of new antiviral drugs is severely hindered by inability to define populations of individuals in the early stages of infection who might benefit from treatment.

In accordance with the present invention, an ultracentrifuge tube is provided which comprises upper, middle and lower regions of successively smaller diameters. In one embodiment, the tube has an upper region for receiving a sample, a funnel-shaped middle region and a lower narrow tubular microbanding region. The diameter of the lower region may be 0.25 inch or less, preferably 0.1 inch or less, more preferably 0.1 to 0.08 inch, and most preferably 0.08 to 0.039 inch. Smaller diameter microbanding regions are feasible and are within the province of this disclosure. The length of the lower region is typically between 5% to 25% of the length of the tube. In one aspect, the tube may also include a seal with a central opening which can be plugged and unplugged.

In accordance with the present invention, a bucket is provided for holding an ultracentrifuge tube. The bucket comprises upper and lower regions which may be of successively smaller diameters, may have inserts to successively decrease the inner diameter, or may be of uniform internal diameter, and may further comprise a third region which attaches the bucket to a rotor.

Further in accordance with the present invention, a method is provided for concentrating microorganisms. As used herein, the term "microorganisms" is intended to include viruses, myoplasmas, rickettsia, yeast and bacteria. The method comprises ultracentrifugation of a sample containing the microorganism in an ultracentrifuge tube described herein. The ultracentrifugation may include the formation of density gradients and/or the staining of the microorganism(s). In one aspect, the staining can be used to distinguish the DNA or RNA content of a virus. The banding of the microorganisms upon ultracentrifugation can be used to identify the microorganisms.

In a further aspect of the invention, the concentrated microorganisms are further characterized by conventional techniques such as mass spectrometry, flow cytometry, optical mapping, isopycnic banding densities, fluorescence, restriction enzyme analysis, genome size, enzymatic or chemical resistance/susceptibility, immunochemistry and the like. In another aspect of the invention, the amount or titre of the microorganisms can be determined.

In accordance with the present invention, a system is provided for measuring fluorescence from a sample in a centrifuge tube. In one embodiment, the system includes a centrifuge tube, a light source, such as a laser, and a detector to detect light passing through the sample or emitted from the sample upon light passing through it. Optical filters select and separate the exciting and emitted wavelengths of light.

The internal surfaces of the tubes and especially the funnel portion must be very smooth in order to prevent small virus particles from being retarded by surface irregularities, and in addition, the surfaces must be treated so that infectious particles are not adsorbed. Polishing of plastic

surfaces is done by brief exposure to a solvent vapor. For example, polycarbonate is polished by brief exposure to heated methylene chloride gas. Plastic surfaces are modified to prevent adsorption of infectious particles by exposure to dilute solutions of proteins such as bovine serum albumin or gelatin, or to charged polymers such as heparin or derivatives of heparin. Both of these procedures are well known to those practiced in the arts.

Further in accordance with the present invention, a system is provided for counting particles concentrated in a small volume. The system includes a container in which the particles are concentrated, a capillary tube, two pumps, means for moving the container relative to the capillary tube, a flow cell, a light source and detector. Alternatively, fluid may be moved by gas pressure instead of pumps.

BRIEF DESCRIPTION OF THE DRAWINGS

Figure 1 shows an S-rho plot for a typical tissue and for representative viruses.

Figures 2A-2C are a diagrammatic representation of one embodiment of a centrifugal microbanding tube and its use.

Figures 3A-3G show alternative embodiments of microbanding tubes and use in a rotor (3F).

Figures 4A and 4B illustrate a centrifuge swinging bucket design that allows higher speed fractionation of large sample volumes.

Figure 5 illustrates a complete system including vertical monochromatic laser illumination, goniometer and X-Y stage for supporting and positioning microbanding tube, microbanding tube with banded viruses particles, and camera system.

Figure 6 illustrates a complete system including interference filter light sources, light pipe illumination, digital data acquisition, and CRT data presentation.

Figure 7 illustrates a method for recovering banded virus particles using a micropipette, and counting them by flow cytometry.

Figures 8A-8C illustrate details of band recovery.

Figures 9A-9F illustrate one embodiment of a closure for swinging bucket rotor centrifuge tubes and detection of a sample with respect to the tubes.

DETAILED DESCRIPTION OF THE INVENTION

The invention is directed to methods of identifying and measuring the presence of microbial agents such as bacteria and viruses in biological samples. The methods include centrifugation steps

to purify the microbial agents in a very small volume. The agents are then assayed by means such as isopycnic banding density, fluorescence or mass spectrometry.

It is an object of this invention to develop integrated systems and methods in which suspensions containing microorganisms, including infectious agents, are stained with one or more fluorescent dyes, in which a step or continuous gradient is automatically formed during centrifugation, in which the microorganisms are centrifuged away from the stain-containing suspending medium and are washed free of external stain, are concentrated in a gradient of very small cross section, separated according to their isopycnic banding densities, their banding densities determined, and the microorganisms detected by fluorescence.

It is a further object of this invention to concentrate microorganisms, including infectious agents, into microbands by a factor of 1-5,000.

It is a further object of this invention to expose the microorganisms, such as infectious agents, to reagents including detergents, surfactants, enzymes, or organic solvents contained in distinct zones in a density gradient to dissolve or disassemble contaminating particles to prevent them from banding with the microorganisms, and to separate stained particles from the free stain of the initial sample volume.

It is a further object of this invention to use one or more dyes which bind differentially to RNA, single stranded DNA or double stranded DNA to allow these to be distinguished by their fluorescent spectra.

It is a further object of this invention to provide for the concentration of banded microorganisms, for example infectious agents, by resuspending the banding gradient, which is typically 0.04 mL, to approximately 4 mL in water or a very dilute buffer, and pelleting the microorganisms one or more times to provide a concentrated pellet free of gradient materials for mass spectrometric analysis, for counting by epifluorescent microscopy or by flow cytometry.

It is a further object of this invention to provide means for the diagnosis of infectious diseases which minimize exposure of laboratory personnel to infectious agents.

It is an additional object of this invention to provide means for preparing nucleic acids from small quantities of microorganisms, including infectious agents, to determine the masses of intact nucleic acid molecules, and for characterization of fragments produced by restriction enzymes using either flow cytometry or epifluorescence microscopy.

It is an additional object of this invention to determine the banding densities of the microorganisms, such as infectious agents, accurately by reference to the positions of calibrated particles added to the gradients.

For ease of description, the invention will be described with reference to viruses as the microorganisms. It will be understood that the invention is also applicable to other microorganisms, including mycoplasmas, yeast and bacteria. The invention is particularly suited for the identification of infectious agents, and will be described in this context.

Figure 1 is a graph depicting the sedimentation coefficients and isopycnic banding densities of subcellular organelles and viruses to illustrate the concept of the "Virus Window" (Anderson, 1966). It is evident that viruses have a relatively narrow range of sedimentation coefficients and banding densities and may be isolated from a tissue homogenate or from blood in a high state of purity using high resolution S- ρ separation systems. For a complete description of high resolution S- ρ centrifugal methods and of centrifuge development for virus isolation, refer to National Cancer Institute Monograph 21, The Development of Zonal Centrifuges and Ancillary Systems for Tissue Fractionation and Analysis, U.S. Department of Health, Education and Welfare, Public Health Service, 1966. This work describes S- ρ separation theory and systems, and the use of colored plastic beads of graded densities as density markers.

In practice, a blood sample or tissue homogenate is centrifuged to sediment all particles having sedimentation rates higher than that of the particle or particles to be analyzed. For viruses, that means particles of circa 10,000 S and above are discarded. The supernatant after such a separation is then used as the sample for second dimension isopycnic banding separations carried out in microbanding tubes as described here, using centrifugation conditions which will sediment and isopycnicly band all known infectious particles.

One picomole of virus would contain 6.022×10^{11} viral particles, while 6×10^9 virions would contain 1 picomole of a viral coat protein present in 100 copies per virion. Quantitative polymerase chain reaction (PCR) has been used to demonstrate that in many infectious diseases $> 10^8$ virus particles are present per mL of plasma or serum. Hence, if the virions from a 5-10 mL biological sample containing 10^8 virions/mL are concentrated to a microliter or two, and then applied to a very small target area, individual viral proteins can be detected using MALDI-TOF-MS (Krishnanurthy et al., 1996; Holland et al., 1966). Using electrospray techniques, samples containing 10^6 virus particles/mL can be detected, while with flow cytometry and immobilized DNA epifluorescence microscopy, even fewer particles are required (Hara et al., 1991; Hennes and Suttle 1995). The

application of these methods to bacteria may require a pre-separation of proteins to reduce the complexity of the sample. In mass spectrometry, detection has been by charged ion detection, and the limitations of such detection have set the upper limits to the size of proteins and nucleic acids that can be detected. Mass spectrometric methods have now been described which allow masses
5 of biological particles above 100,000 daltons to be measured.

In order to work with such levels of virus, the virus must be concentrated into a very small volume. This concentration is accomplished during the second dimension of centrifugation (the isopycnic banding step) by banding the virus using a centrifuge tube specially designed to concentrate the virus into a microband after passage through gradient layers that wash the particles
10 and expose them to selected reagents. An example of such a microbanding centrifuge tube is shown in Figures 2A-2C. Figure 2A illustrates diagrammatically a hollow transparent centrifuge tube 1 with an upper sample volume 2, grading into a serrated funnel region 3 having successively tapered and parallel-wall sections 4-6, constricting down to a narrow tubular microbanding region 7. The serrated funnel region 3 is an improvement over centrifuge tubes which simply taper from top to
15 bottom without including a serrated region. By serrations is meant, for example, concentric rings or edges or lips. These rings, edges or lips are preferably continuous around the inner diameter of the centrifuge tube, but this is not required. For example, three projections from the inner wall of the centrifuge tube spaced equally around the diameter could be used to hold a disk in place. The term serrations is meant to include such possibilities but does not include a straight tapering with
20 no rings, edges, lips or projections on the inner surface of the centrifuge tube. The serrations can be used as rests onto which disks can be placed to separate two or more layers of liquid. Although disks can be placed into tubes which simply taper without serrations, the disks in such tapered tubes can be easily tipped up on one edge by pushing down on the opposing edge. This would cause a premature mixing of the layers which are to be separated by the disks. The serrated region allows
25 disks to lie flat and prevents the disks from being accidentally tipped up. As an example, the centrifuge tube may be 3.45 inches from top to bottom, have an outer diameter at the top of 0.562 inch, and have an inner diameter in the bottom microbanding region 7 of 0.064 inch. Such a tube is suitable for use in an SW41 Ti (Beckman) rotor. The inside surface of the tube is preferably polished using conventional techniques, including vapor polishing, so that the virus particles do not
30 stick to the wall of the tube. Additionally, the internal surfaces of the tubes may be coated with a protein or polymer to prevent particle adhesion, as is well known in the art.

Figure 2B illustrates how the tube is loaded at rest with a series of fluids of decreasing physical density. The tube shown comprises a series of serrations onto which can be laid disks to separate one layer of fluid from the next layer of fluid. Liquid **8** is denser than any particle to be recovered, and is used to partially fill the microbanding region **7**. When a less dense fluid **9** is pipetted in with a micropipet an air bubble **10** (wherein by air is meant atmospheric air or another gas) may be left to keep the fluids **8** and **9** separate. Similarly when the first overlay fluid **11** is introduced, air bubble **12** may be left in place, thus keeping the three liquids separate until centrifugation is commenced. A tube with an inner diameter of 0.064 inches in microbanding region **7** is suitable for allowing an air bubble to be left in place to separate two layers of liquid. Alternatively, the air bubbles may be left out and the fluids allowed to diffuse together to create a density gradient. Fluid **11** is covered with a light porous plastic disk **13**, preferably of sintered polyethylene or polypropylene, which fits in place in the first serration. A fluid **14**, less dense than fluid **11**, which may contain one or more reagents, is then introduced, and covered with disk **15**, followed by even less dense liquid **16** which is covered with disk **17**. The entire system is stable until centrifuged. Before use the sample layer **18**, which has a density less than that of fluid **16** is then added up to level **19**. The tubes are then centrifuged at high speed in metal shields, typically with water or other liquid added to the shields. In addition, the tubes may be supported by fitting adapters which fill the space between the tubes and the shields, and water may be added to fill any spaces between the tubes, adapters and shields to provide additional support. Optionally the tubes may be capped (as shown in Figures 9A-9F, described in further detail below), to minimize the chances of operator infection.

Figure 2C illustrates diagrammatically a tube after centrifugation. The porous separation disks **13**, **15**, and **17** have risen to the top of the tube, and sample layer **18** is cleared of virus, and the original step gradient has changed, by diffusion, into one of a series of shallow gradients. In addition, gas bubbles **10** and **12** have also moved centripetally, and fluids **8** and **9** have come into contact to form a steep gradient by diffusion. As centrifugation proceeds, the slope of this gradient diminishes, producing a banding gradient of a width suitable for banding the infectious agents. For cesium chloride gradients, the densities typically range from 1.18 to 1.55 g/ml. These gradient steps may not only contain reagents to dissolve non-viral particles, but also serve to wash excess fluorescent dye away from the particles. For example, various detergents or enzymes such as proteases may be added either to the sample layer **18** or to other layers such as **14** or **16**. Fluorescent dyes may also be present in these regions. The free dye will not enter the lower, more dense regions

in which the virus bands and therefore the centrifugation will purify the viruses from all of the reagents which may be present in the upper, less dense layers. After centrifugation, the microbanding region of the tube contains the upper portion of the banding gradient 27, banded virus 28 (including any dye bound to the virus or viral nucleic acid) and lower dense portion of the banding gradient 29, and the gradient formed between them by diffusion.

Figures 3A-3G illustrate alternative embodiments of tubes useful for microbanding of viruses and bacteria and all have a serrated internal construction which allows one or more light barriers to be positioned and retained at rest. Tubes shown in Figures 3A-3D and 3G are designed to be centrifuged in swinging bucket rotors so that the tubes are horizontal during centrifugation and vertical at rest. The tube shown in Figure 3A is the more conventional design with a sample reservoir 31, a serrated funnel region 32, and a microbanding section 33. The tube shown in Figure 3B is similar to that of Figure 3A, but it is supported in a centrifuge shield by a support insert 34 which may be of plastic or metal. The tubes shown in Figures 3B-3E fill a rotor chamber completely. The tube of Figure 3C has an opaque bottom section 35 which absorbs scattered light, while that shown in Figure 3D has a bulbous section 36 at the bottom of the microbanding tube 37 to contain an excess volume of the fluid forming the dense end of the gradient, thus stabilizing the gradient. The tube shown in Figure 3E is designed to be centrifuged in an angle head rotor as shown in Figure 3F, and has a linearly continuous wall 38 along one side positioned in the rotor so that particles may readily slide down to microbanding region 40. The tube shown in Figure 3G illustrates how a very large microbanding tube may be fabricated.

Figures 4A-4B illustrate how the tube of Figure 3G may be centrifuged at higher speed than tubes having a constant radius from top to curved bottom. This is accomplished by using a metal, plastic or carbon fiber shield 45 which matches the dimensions of tube 46. The shield has a cap 47 and the shield or bucket swings on integral attachment 48, as is conventionally done in high speed swinging bucket rotors. Tip 49 of the shield is much smaller diameter than the upper section of the shield, has much less mass swinging at its maximum radius, and hence can reach much higher speeds than is the case with shields of uniform internal diameter. This makes possible isolation of trace amounts of virus from much larger volumes than would otherwise be the case. During centrifugation using rotor 50 driven by drive 51, shield and tube 52 assume a horizontal position as shown.

The microbanded viruses can be analyzed at this stage or they can be collected, diluted, and further processed. To analyze the microbanded viruses at this stage, they can be detected by a

system as shown in Figure 5. For example, the isopycnic banding step or an earlier step may have included a fluorescent dye or fluorescent dyes within the solution with which the virus was mixed or through which the virus was centrifuged. Dyes are known with which intact viruses may be stained and which can distinguish between RNA, DNA, single stranded nucleic acid and double stranded nucleic acid thereby allowing one to detect the presence or absence of an infectious agent, and further to determine which type of virus one has purified. The apparatus of Figure 5 can be used to analyze these stained particles.

A scanning and detection system is illustrated schematically in Figure 5 where microbanding tube **60** is held in a vertical position on mount **61** supported by goniometers **62** and **63** which are in turn supported by X-Y movements **64** and **65** in such a manner as to align and center the microbanding section of tube **60** with respect to laser beam **66**. Laser beam **66** is generated by a laser **67**, which may be an argon ion laser producing coherent light at 458, 488, 496, 502, and 515 nm. The beam passes through an interference or other filter **68** to isolate one wavelength, and is reflected down into the microbanding tube by dichroic mirror **69**. The fluorescent banded particle zone **70** is photographed or electronically scanned by camera **71** through emission filter **72**. The entire system may be enclosed to eliminate stray light, and filters **68** and **72** may be replaced by filter wheels (not shown) to optimize detection using fluorescent dyes which absorb and emit at different wavelengths, or to distinguish ssDNA, dsDNA and RNA by differences in the spectra of emitted fluorescent light.. Electronic shutters may be attached to the laser to minimize sample exposure to light and to the camera to control exposure. The goniometers and X-Y movements may also be motor driven and remotely controlled, and the entire system may be controlled by a computer (not shown).

Figure 6 illustrates a different version of the scanning system which can cover all of the visible spectrum and on into the near ultraviolet. Microbanding tube **80** is aligned in a fixed support between transparent intensity equilibrators **81** and **82** attached to light pipes **83** and **84** which are in turn attached to intensity equilibrators **85** illuminated through filter **86** by condensing lens **87** and light source **88**. Filter **86** is one of a set attached to filter wheel **89** indexed by motor **90**. The result is uniform illumination from two sides of one or more bands **91**, **92** and **93**. The image is captured through emission filter **94** by digital camera **95** and the image stored, processed and displayed by computer **96** on CRT **97**. Filter **94** may be replaced by a filter wheel identical to **89** and **90** so that, with both an excitation filter wheel and an emission filter wheel and a wide spectrum light source such as a xenon lamp or a halogen lamp, a wide variety of combination of exciting and emitting

light may be chosen, which in turn makes possible use of a wide variety of fluorescent dyes. Both fluorescent light and light scatter at a chosen wavelength may be employed for particle detection. This arrangement facilitates distinction between ssDNA, dsDNA and RNA.

The processed image **98** may be displayed to show a picture of the tube and contained bands **99, 100** and **101**. The amount of light from each band may be integrated and displayed as peaks **102, 103,** and **104,** and in addition the integrated values may be displayed digitally (not shown). The entire system including shutters on the light source and camera (not shown), filter movement and positioning, and focusing of the camera may be digitally controlled by computer **96**.

Display bands **99** and **101,** representing centrifuge tube bands **91** and **93** may be fluorescent or non-fluorescent density marker beads of known density, and the virus band **92** represented by display band **103**. The banding density of the virus may be determined by interpolation from the positions of the density markers. When non-fluorescent density markers are used, these are detected by scattered light using identical filters at positions **86** and **94**. A second image using suitable and different filters is then captured which is comprised solely of fluorescent light. The two images are electronically inter-compared and the physical density of the infectious agent determined by interpolation.

At this stage, the virus can be identified as being a DNA virus or an RNA virus, and if a DNA virus it can be determined whether it is single stranded or double stranded. Furthermore, the density of the virus can be determined. This data can be used to help identify the type of virus which has been purified. Nevertheless, it may be desirable or necessary to gather more data to fully determine what the exact virus is and also to determine the original viral titre.

Figure 7 illustrates diagrammatically counting of individual fluorescent particles recovered from a tube **110** containing zones of banded virus **111** and **112** after all fluid above the banding gradient has been removed and replaced. The tube is placed in a tube holder **113,** and an overlay of deionized water or very dilute buffer **114** is introduced above the gradient supplied through tube **115** to replace the volume drawn up in the probe **117**. The tube may be closed at the top by a plastic closure **116**. The capillary probe **117** is held stationary, and the microbanding tube **110** is slowly raised under it. The tube holder **113** is part of a precision drive mechanism **118** and associated stepping motor **119** that moves the tube holder vertically at a very slow and controllable rate. A slow steady stream of fluid is drawn into constriction **120** which is centered in sheath stream **121** provided by pump **122**. The result is a constant flow of fluid through flow cell **123** with a fine virus containing stream in the center, elongated and extended by the flowing sheath. A second pump **124**

withdraws fluid upward at a constant rate from the flow cell, which rate is greater than the rate at which piston pump **122** injects fluid into sheath **121**. The difference in the rates of pumps **124** and **122** is made up by the fluid coming through capillary probe **117**. The fluid coming through capillary probe **117** is a mixture of virus plus fluid from the overlay which is introduced via tube **115**.

The flow cell **123** is illuminated by laser beam **125** produced by laser **126**, that passes through exciting filter **127**. Emitted light is isolated by emission filter **128** and detected by a photomultiplier **129**. The output from the photomultiplier **129** is integrated at intervals by computer **130**, and the integrated signal vs. time is displayed on CRT **131**. When two viral bands are present, two peaks such as **132** and **133**, are displayed. Depending on the number of fluorescent particles present, the signal generated from a band may be integrated into a peak, or, if the suspension is sufficiently dilute, the particles may be counted individually, the values binned, and the integrated results displayed.

In order to count the particles as just described, it is necessary that the virus particles are greatly diluted as they pass through flow cell **123**. Figure 8 illustrates diagrammatically how the problem of making an initial dilution of a very small-volume virus band for counting individual particles is accomplished. Figure 8A shows a tube **110** as in Figure 7, with a section indicated which is shown enlarged in Figure 8B, which in turn shows the section of that panel enlarged in Figure 8C. As the movement upward of the microbanding tube causes the capillary tube to move toward the tube bottom, the difference in pumping rates of the two pistons attached to the flow cell causes fluid to flow up the capillary where it is diluted as described by the combined action of pumps **122** and **124** of Figure 7. However, the amount of fluid drawn into the capillary **117** is much greater than the volume of fluid effectively displaced from the banding gradient by the relative movements of the capillary and the microbanding tube. This volume is replaced by fluid flowing into tube **115** through cap **116** which is initially allowed to flow in until the tube **110** is full. This fluid is much less dense than the density of the fluid at the top of the gradient in the microbanding region, and causes minimal disturbance in the gradient. As shown in Figure 8B, the capillary **117** slowly approaches virus band **144**, and, as shown in Figure 8C, a small amount of gradient liquid **145** is diluted by a larger amount of supernatant fluid **114** as it flows up the capillary. In this manner, a sharp band of virus particles **144** is diluted and moves through the flow cell as, volumetrically, a larger band, but with little effective loss of resolution. This technique provides the dilution necessary to make counting of individual virus particles feasible and accurate. The

amount of dilution can be controlled such that the concentration of microorganisms in the capillary tube is less than one-half or one-tenth, or one-hundredth, or one-thousandth, or one ten-thousandth, or one-millionth, or one-billionth of the concentration in the band in the lower region of said tube.

In addition to counting the particles or determining the titre of a virus, the amount of DNA
5 in the virus or other microbe can be determined for individual particles. In this aspect of the invention, the amount of DNA in the particles is measured by flow fluorescence analysis (Goodwin et al., 1993) or epifluorescence analysis (Jing et al., 1998). In this manner, yeast, bacteria, mycoplasma and virus can be distinguished as groups. For example, it is known that viruses contain
10 5-200 x 10³ bases or base pairs, *E. coli*, a typical bacterium, contains 4 x 10⁶ base pairs, while a typical yeast cell contains 1.3 x 10⁷ base pairs. Thus, an estimate of the amount of DNA or RNA present allows the class of an infectious agent to be determined.

Thus, the size of a genome can be determined. In this embodiment of the invention, the genome is extracted from the microorganism band and immobilized on a solid support. The immobilized DNA is stained and electronically imaged using an epifluorescence microscope (Jing
15 et al., 1998). The length of the individual nucleic acid molecules can then be measured.

The technique of microbanding is useful not merely for staining the virus with dyes and being able to count the virus particles. Once the viruses from a biological sample have been highly purified and concentrated by the two dimensional centrifugation technique as described above using microbanding centrifuge tubes, the viruses are amenable for use in many other assays.

When an infectious agent is banded in a microbanding tube, the band may also be
20 judiciously removed using a capillary needle in a volume of a few microliters, diluted to 5 mL or more with very dilute buffer or deionized water to dilute the gradient materials by a factor as large as 1,000, and then pelleted in a fresh microbanding tube. The supernatant may then be carefully withdrawn by a suction capillary, and the virus or other agent resuspended in approximately 1
25 microliter using a syringe made, for example, of fine Teflon® tubing fitted with a very small stainless steel wire plunger to fit. The sample may then be transferred to a mass spectrometer target, mixed with a matrix dye, and used for matrix assisted laser desorption ionization time of flight mass spectrometry (MALDI-TOF-MS) to determine directly the masses of viral coat proteins or of bacterial cell proteins. Technology described for sample concentration may also be applied, without
30 a matrix dye, to electrospray or other mass spectrometric analysis systems, including the detection of intact viral mass.

A system similar to that shown in Figure 7 may also be used to produce the equivalent of molecular restriction fragment length maps of DNA molecules using restriction enzymes. For this work, virus or bacterial particle bands may be diluted and sedimented as described, after which the DNA may be extracted using detergents or other reagents well known in the art, treated with a restriction enzyme and a fluorescent dye, and the fragment sizes determined by flow cytometry (Goodwin et al., 1993; Hammond et al., U.S. Patent No. 5,558,998). Extracted DNA may also be immobilized on a solid support, stained with a fluorescent dye, and photographed using an epifluorescence microscope to determine the length of DNA molecules. The preparation may then be treated with a restriction endonuclease, and the number and lengths of the oligonucleotide fragments determined (Jing et al., 1998). These data are then compared with a database listing the expected fragment lengths for different viral or bacterial species to identify each agent. DNA fragment lengths may also be determined by gel electrophoresis.

Fluorescence labeled antibodies may also be added to the particle suspension studied, and the presence or absence of the label in isopycnicly banded particles determined. This approach is useful for specific identifications, and the use of a set of antibodies labeled with dyes having different and unique spectral characteristics allows the presence or absence of a series of agents to be determined. Alternatively antibodies labeled with chelators for rare earth's such as Europium and Terbium may be employed, in which case delayed fluorescence is measured.

Serum or plasma typically has a physical density between 1.026 and 1.031. Viruses typically have banding densities between 1.17 and 1.55 in cesium chloride, and at much lower densities in iodinated gradient materials such as Iodixanol or sucrose (Graham et al., 1994). The intermediate wash and reagent layers between the sample and the banding gradient must therefore have densities less than the density of the lightest virus to be banded. Buffers used to dissolve gradient material for virus isolation include 0.05 M sodium borate, and 0.02 M sodium cyanide, both of which prevent bacterial growth.

With human serum or plasma, centrifugation sufficient to remove platelets and other particles having sedimentation coefficients of approximately 10^4 S is used before banding of virus particles.

The banding density of virus particles depends on the nucleic acid/protein ratio, and the presence or absence of lipids and lipoproteins. Hence attachment of specific identifying antibodies labeled with fluorescent dyes should not only allow identification by fluorescence but by a banding density change.

To assist in identifying particles by density, fluorescent particles of known density may be included in the sample as shown in Figure 6. These particles may include known fixed and fluorescently stained virus or bacterial particles of known banding density, or very small fluorescently labeled or non-fluorescently labeled plastic beads. When polystyrene latex particles are coated with antibodies, their banding densities are increased appreciably, and the density may be further increased by reaction of the antibody-coated particles with the antigen for which the antibodies are specific (Anderson and Breillatt, 1971). Antibody-coated fluorescent polystyrene beads may therefore be used not only to locate virus particles but to identify them.

The stains which are currently most useful are described in the Handbook of Fluorescent Probes and Research Chemicals, R.P. Haugland, ed., Molecular Probes, Inc., Eugene, Oregon (1996), which lists the abbreviated dye names, their chemical names, absorption and emission maxima, and the filter combinations most used.

For work with human pathogens, safe operation and containment are important (Cho et al., 1966). Use of swinging bucket rotors, while optimal from a physico-chemical point of view, require extensive manipulation and have more parts than an angle-head rotor. The tubes described in Figure 3E are designed to be used in angle-head rotors, and allow sedimenting particles to travel along a wall at one unchanging angle. Such rotors are easier to use and handle in containment than are swinging bucket rotors, however, sedimentation in an angle head rotor is far from ideal. Hence, the development of methods and devices for safely working with swinging bucket rotors is important.

High speed centrifuge tubes are notoriously difficult to seal effectively and are a potential source of infection to laboratory personnel. In practice, nearly all high speed swinging bucket rotor tubes are not themselves sealed, but are enclosed in a metal bucket which is sealed with a metal cap which does not seal the tube. The centrifuge tubes are therefore open when loaded, moved to the centrifuge rotor, inserted, and removed. It is very difficult to decontaminate the outside of an open tube containing a density gradient without disturbing the gradient. In the present application it is desirable to be able to effectively seal the plastic tubes in such a manner that the outside surfaces can be cleaned with a suitable disinfectant before the tubes are inserted into centrifuge shields, and to be able to handle them safely until they are scanned.

Sealing is done, as shown in Figure 9A, by inserting an annular ring seal 151, having a physical density less than that of water, into tube 152. Ring 151 is slightly tapered so that it fits very tightly into tube 152, and has a center hole which can be plugged and unplugged. In one embodiment, the center hole is threaded to accept a short, plastic flat-head screw. Initially two

gradient components, including a lighter solution **153** and a denser solution **155**, are introduced to the bottom microbanding region with a small air bubble **154** between, as previously described. As shown in Figure 9B, the solution **156** containing the infectious agent or other particles is then introduced through tube **157**, leaving bubble **158** to separate the sample from the upper gradient solution. The volume of sample introduced does not completely fill the centrifuge tube, leaving space **159** empty. The tube is then sealed, as shown in Figure 9C with, for example, a plastic flat head screw **160**, leaving air bubble **160** in place. The outside of the tube is then sterilized by immersing it in a disinfectant such as a sodium hypochlorite or hydrogen peroxide solution, followed by a water wash and gentle drying – all with the tube in an upright position. After centrifugation, as shown in Figure 9D, the plastic upper seal has been driven downward by centrifugal force a small distance as the entrapped air rises around the plastic seal. However, since the seal has a density less than water, it is retained at the top of the liquid sample, leaving a small lip **160** which may be grasped with a hemostat to remove the tube from the centrifuge shield. During centrifugation, the infectious particles are sedimented out of liquid **163** and produce band **164** in the gradient. The screw in the ring seal is then removed, and, as shown in Figure 9E, the supernatant liquid **165**, which may contain a fluorescent dye, is removed through tube **166**, leaving meniscus **167**. As shown in Figure 9F, a laser beam **168**, entering the tube from above, is then aligned with the tube, causing the banded infectious agent to emit fluorescent light for detection as previously described.

When a step gradient containing various reagents in addition to those used for isopycnic banding is employed, as illustrated in Figure 2, the discs used to separate the several solutions rise to the top and would not allow the use of vertical laser illumination as shown in Figure 9F without removing the seal and the discs. In this instance, side illumination, as illustrated in Figure 6 would be employed.

The laser or delayed fluorescence systems can be completely contained, the mechanical operations done remotely through small stepping motors, and the tubes moved in and out of the contained system under remote control.

These techniques can be combined with mass spectrometry and fluorescence-based restriction fragment mapping to allow rapid diagnosis and identification of infectious agents. However, the estimates of the masses of individual proteins are generally taken from published sequence data, and do not include numerous posttranslational modifications. Mass spectrometric data bases must be created to include actual mass measurements of different microorganisms. In

addition, virion protein mass measurements will allow the detection of many genetic variants. However, for many studies of microorganisms, including development of data bases, the key problem has been the development of methods for systematically providing highly concentrated and purified microsamples of microorganisms from patient samples, natural waters, and from tissue culture fluids. This problem is solved by the present invention.

The present invention is described by reference to the following Example, which is offered by way of illustration and are not intended to limit the invention in any manner. Standard techniques well known in the art or the techniques specifically described below were utilized.

EXAMPLE

To illustrate the use of microbanding tubes, experimental studies have been carried out using a small single-stranded non-pathogenic DNA virus ϕ X 174. Approximately 10^{10} virus particles which had been purified by isopycnic banding in CsCl in a microbanding tube such as shown in Figure 2A were suspended in 5 mL of 0.05 M borate buffer, were pelleted in a microbanding tube at 35,000 rpm in a swinging bucket rotor, and were resuspended in approximately 3 μ L for analysis. The analyses were done on a PerSeptive Biosystems DESTRA instrument with an extraction delay time set at 150 nseconds using a matrix of sinapinic acid. Bovine insulin (Mw=5,734.59) and horse heart apomyoglobin (Mw=16,952) were used as 1 and 2 pmole standards. The results are shown in Table 1. The ϕ X 174 masses for virion capsid proteins F, G, H and J are calculated from published sequence data. The differences between the calculated and experimental values for F and H are probably due to posttranslational modifications. The probability that an unrelated virus could have subunits of the same masses listed is vanishingly small. However, even more definitive protein identifications can be made by treating viral proteins with proteolytic enzymes such as trypsin and determining the masses of the peptide fragments produced. Computer programs are available which calculate the sizes of fragments of proteins of known sequence by well characterized enzymes. Such programs include Protein Prospector (available from the University of California, San Francisco) and ProFound (available from Rockefeller University).

Table 1

Mass Spectrometric Analysis of ϕ X 174 Virion Proteins

<u>Protein</u>	<u>Calculated Mass</u>	<u>Experimental Mass</u>	<u>Mass Difference</u>	<u>% Difference</u>
F	48,351.53	48,407.4	+55.9	0.12 %

G	19,046.73	19,046.7	0.0	0.00 %
H	34,419.25	34,466.1	+46.9	0.14 %
J	4,095.78	4,097.03	+1.2	0.03%

5 This example demonstrates that highly purified and concentrated suspensions of microorganisms can be isolated from biological samples such as, but not limited to, patient samples such as plasma, urine, feces and tissues, natural water and tissue culture fluids. This example further demonstrates that such purified and concentrated microorganisms can then be identified, for example, using mass spectrometry to identify viruses.

10 While the invention has been disclosed in this patent application by reference to the details of preferred embodiments of the invention, it is to be understood that the disclosure is intended in an illustrative rather than in a limiting sense, as it is contemplated that modifications will readily occur to those skilled in the art, within the spirit of the invention and the scope of the appended claims.

15

LIST OF REFERENCES

- Anderson, N.G., ed. (1966). "The Development of Zonal Centrifuges." *Natl. Cancer Inst. Monogr.* 21.
- Anderson, N.G. et al. (1966). "Separation of subcellular components and viruses by combined rate- and isopycnic-zonal centrifugation." *In The Development of Zonal Centrifuges*. N.G. Anderson, ed. *National Cancer Institute Monograph 21*: 253-284.
- Anderson, N.G. et al. (1967). "Isolation of viral particles from large fluid volumes." *In Transmission of Viruses by the Water Route*, G. Berg ed., Interscience Publishers, NY, pp. 75-88.
- Anderson, N.G. (1968). "Analytical techniques for cell fractions. VIII. Analytical differential centrifugation in angle-head rotors." *Anal. Biochem.* 23: 72-83.
- Anderson, N.G. and Breillatt, J.P. (1971). "Isopycnetric serology: A new technique based on buoyant density changes in latex beads." *Nature* 231: 112-114.
- Bergh, O. et al. (1989). "High abundance of viruses found in aquatic environments." *Nature* 340: 467-468.
- Borsheim, K.Y. et al. (1990). "Enumeration and biomass estimation of planktonic bacteria and viruses by transmission electron microscopy." *Applied Environ. Microbiol.* 56: 352-356.
- Chang, Y. et al. (1994). "Identification of herpes virus-like DNA sequences in AIDS-associated Kaposi's sarcoma." *Science* 265: 1865-1869.
- Cho, N. et al. (1966). "Problems in biocontainment." *Natl. Cancer Inst. Monogr.* 21: 485-502.

- Claydon, M.A. et al. (1996). "The rapid identification of intact microorganisms using mass spectrometry." *Nature Biotechnology* 14: 1584-1586.
- Fenselau, C. (ed.) (1994). "Mass spectrometry for the characterization of micro-organisms." *ACS Symposium Series*, Vol. 541, ACS, Washington DC.
- Fredricks, D.M. and Relman, D.A. (1996). "Sequence-based evidence of microbial disease causation: When Koch's postulates don't fit." *J. NIH Res.* 8: 39-44.
- Gao, S.-J. and Moore, P.S. (1996). "Molecular approaches to the identification of unculturable infectious agents." *Emerging Infectious Diseases* 2: 159-167.
- Goodwin, P.M. et al. (1993). "Rapid sizing of individual fluorescently stained DNA fragments by flow cytometry." *Nucl. Acids Res.* 21: 803-806.
- Graham, J. et al. (1994). "The preparation of subcellular organelles from mouse liver in self-generated gradients of Iodixonol." *Anal. Biochem.* 220: 367-373.
- Hara, S. et al. (1991). "Abundance of viruses in marine waters: Assessment by epifluorescence and transmission electron microscopy." *Applied Environ. Microbiol.* 57: 2731-1734.
- Harris, W.W. et al. (1966). "Unusual particles in human plasma from leukemia and lymphosarcoma." *In The Development of Zonal Centrifuges. National Cancer Institute Monograph* 21: 289-394.
- Haugland, R.P. (1996). *Handbook of Fluorescent Probes and Research Chemicals*, 6th ed. Molecular Probes Inc., Eugene OR, p. 679
- Hennes, K.P. and Suttle, C.A. (1995). "Direct counts of viruses in natural waters and laboratory cultures by epifluorescence microscopy." *Limno. Oceanogr.* 40: 1050-1055.
- Hennes, K.P. et al. (1995). "Fluorescently labeled virus probes show that natural virus populations can control the structure of marine microbial communities." *Applied Environ. Microbiol.* 61: 3623-3627.
- Hirons, G.T. et al. (1994). "TOTO and YOYO: New very bright fluorochromes for DNA content analysis by flow cytometry." *Cytom.* 15: 129-140.
- Holland, R.D. et al. (1996). "Rapid identification of intact whole bacteria based on spectral patterns using matrix assisted laser desorption ionization with time of flight mass spectrometry." *Rapid Commun. Mass Spectrom.* 10: 1227-1232.
- Jing, J. et al. (1998). Automated high resolution optical mapping using arrayed, fluid-fixed DNA molecules. *Proc. Natl. Acad. Sci. USA* 95: 8046-51.
- Kovacs, E. (1962). Chemical dissection of mammalian cells with liberation of biologically intact viruses. *Z. Naturforschg.* 17: 234-240.
- Krishnanurthy, T. et al. (1996). "Detection of pathogenic and non-pathogenic bacteria by matrix assisted laser desorption ionization time of flight mass spectrometry." *Rapid Commun. Mass Spectrom.* 10: 883-888.
- Liang, X. et al. (1996). "Determination of bacterial protein profiles by matrix assisted laser desorption ionization mass spectrometry with high performance liquid chromatography." *Rapid Commun. Mass Spectrom.* 10: 1219-1226.

- Linnen, J. et al. (1996). "Molecular cloning and disease association of hepatitis G virus: a transfusion-transmissible agent." *Science* 271: 505-508.
- Mazzone, H.M. (1998). CRC Handbook of Viruses. CRC Press, Boca Raton, p. 206.
- Samad, A.H. et al. (1995). "Mapping the genome one molecule at a time - optical mapping." *Nature* 378: 516-517.
- Simons, J.N. et al. (1995). "Identification of two flavi-virus-like genomes in the GB hepatitis agent." *Proc. Natl. Acad. Sci. USA* 92: 3401-5.
- Siuzdak, G. (1998). Probing viruses with mass spectrometry. *J. Mass Spec.* 33: 203-211.
- Suttle, C.A. (1993). "Enumeration and isolation of viruses." *In Handbook of Methods in Aquatic Microbial Ecology*, Chapter 15. Kemp, P.F., Sherr, B.F., Sherr, E.B. and Cole, J.J., eds. Lewis Publishers, Boca Raton, Fla., pp 121-134.
- Suttle, C.A. and Chen, F. (1992). "Mechanisms and rates of decay of marine viruses in seawater." *Appl. Environ. Microbiol.* 58: 3721-3729.
- Wommack, K.E. et al. (1992). "Distribution of viruses in the Chesapeake Bay." *Appl. Environ. Microbiol.* 58: 2965-2970.
- Yolken, R.H. and Torrey, E.F. (1996). "Viruses, schizophrenia and bipolar disorder." *Clinical Microbiology Reviews* 8: 131-145.
- Zeuzem, S. et al. (1996). "Phylogenetic analysis of hepatitis C virus isolates and their correlation to viremia, liver function tests, and histology." *Hepatology* 24: 1003-1009.

WHAT IS CLAIMED IS:

1. An ultracentrifuge tube comprising an upper centripetal region, a middle region and a lower centrifugal region wherein an inner diameter of said upper region is larger than an inner diameter of said middle region and wherein an inner diameter of said middle region is larger than an inner diameter of said lower region.
2. The ultracentrifuge tube of claim 1, wherein said middle region comprises one or more serrations.
3. The ultracentrifuge tube of claim 1, wherein one wall of said centrifuge tube is linearly continuous.
4. The ultracentrifuge tube of claim 1, wherein said inner diameter of said lower region is smaller than 0.25 inch.
5. The ultracentrifuge tube of claim 1, wherein said lower region is at least 5% of the total length of said tube.
6. The ultracentrifuge tube of claim 1, wherein the inner surfaces are polished by vapor polishing.
7. The ultracentrifuge tube of claim 1, in which the inner surfaces are coated with adhering polymer to prevent adsorption of biological particles.
8. The ultracentrifuge tube of claim 1, wherein said lower region has an inner diameter small enough to trap an air bubble between two layers of liquid such that the air bubble will keep said two layers of liquid separate so long as said centrifuge tube is at rest.
9. A bucket for holding a centrifuge tube wherein said bucket comprises an upper region and a lower region, and wherein said lower region has a smaller outer diameter than said upper region.

10. The bucket of claim 9, wherein said bucket comprises a third region wherein said third region attaches said bucket to a rotor.
11. A method for concentrating microorganisms from a biological sample, wherein said method comprises the steps of:
 - (a) adding a sample containing microorganisms to an ultracentrifuge tube and
 - (b) centrifuging said sample in said tube to concentrate said microorganisms, said ultracentrifuge tube comprising an upper region, a middle region and a lower region wherein an inner diameter of said upper region is larger than an inner diameter of said middle region and wherein an inner diameter of said middle region is larger than an inner diameter of said lower region.
12. The method of claim 11, wherein density gradients are formed in said lower region of said tube.
13. The method of claim 11, which further comprises placing two or more layers of fluid into said lower region of said tube prior to addition of said sample, said layers being separated by air bubbles.
14. The method of claim 11, which further comprises placing two or more layers of fluid into said middle region of said tube prior to addition of said sample, said middle region layers separated by one or more disks inserted into said tube, said disks capable of keeping said layers of fluid separate prior to centrifugation and of floating upwards during centrifugation.
15. The method of claim 14, in which all fluid layers decrease in physical density from a centrifugal to a centripetal direction.
16. The method of claim 14, in which enzymes, reagents, dyes, or fixatives are present in discrete layers and do not sediment appreciably under the conditions of centrifugation employed.

17. The method of claim 14, in which gradient solutes are chosen so that microorganisms preferentially survive passage through reagent layers while contaminating particles are degraded or dissolved.
18. The method of claim 14, in which the reagent layers are chosen to selectively degrade known classes of microorganism while allowing others to sediment to the centripetal isopycnic banding gradient.
19. The method of claim 14, in which bacteria are readily distinguished from viruses.
20. The method of claim 14, wherein said disks are porous.
21. The method of claim 11, which further comprises adding fluorescent stain to said sample.
22. A method for measuring the amount of DNA or RNA in microorganisms, which comprises concentrating the microorganisms according to the method of claim 11 and analyzing the amount of DNA or RNA by flow fluorescence analysis or epifluorescence analysis.
23. A method for distinguishing between single-stranded DNA viruses, double-stranded DNA viruses and RNA viruses present in a biological sample containing viruses, which comprises contacting dyes which can distinguish between said viruses with viruses in said sample, concentrating said viruses according to the method of claim 13, and detecting the bound dyes in a band of virus, whereby the type of nucleic acid present in the viruses is determined.
24. The method of claim 23, wherein said dyes are added to said sample.
25. The method of claim 23, wherein such dyes are added to a layer of fluid added to the tube before the addition of said sample and said viruses contact said dyes during centrifugation.
26. The method of claim 23, wherein said dyes are fluorescent and said bound fluorescent dyes are detected by passing an exciting fluorescent light through said band of virus and

determining a wavelength of peak intensity of emitted fluorescent light from said band of virus.

27. The method of claim 26, which further comprises removing unbound dyes from said tube prior to determining said wavelength of peak intensity.
28. The method of claim 23, wherein said bound dyes are detected by passing an exciting light through said band of virus and determining the spectral distribution of the emitted light.
29. A method for determining an infectious agent titre in a biological sample, which comprises measuring the intensity of emitted fluorescent light of claim 26.
30. A method for determining titre in a biological sample of known volume wherein said method comprises the steps of:
 - (a) concentrating said microorganism according to the method of claim 11;
 - (b) removing fluid from above said lower banding region;
 - (c) overlaying remaining fluid with water or buffer less dense than fluid in said lower region;
 - (d) inserting a capillary tube with an open bottom end into said centrifuge tube such that said open bottom end is above one or more microorganism bands;
 - (e) drawing fluid through said open bottom end of said capillary tube such that said fluid being drawn through said capillary tube forms a stream of fluid which passes through a flow cell where it is analyzed;
 - (f) adding water or buffer to said upper region of said centrifuge tube as fluid is withdrawn in step (e) or as needed to maintain water or buffer above any viral band;
 - (g) moving said centrifuge tube relative to said capillary tube such that said capillary tube moves into said lower region of said centrifuge tube and through any viral band of microorganisms;
 - (h) analyzing for microorganisms in said stream of fluid flowing through said flow cell to determine a number of microorganisms present; and
 - (h) calculating a titre from the determined number of microorganisms and known volume of said biological sample.

31. The method of claim 30, further comprising pumping fluid into a sheath around said stream of fluid exiting from said capillary tube thereby diluting said stream prior to passing through said flow cell.
32. The method of claim 31, wherein said sheath of fluid is pumped at a rate slower than the rate at which fluid passes through said flow cell.
33. The method of claim 32, wherein the flow of each liquid is controlled by gas pressure in place of pumps.
34. The method of claim 30, wherein said microorganisms are at a concentration in said capillary tube less than one-half their concentration in a band of microorganisms in said lower region of said centrifuge tube.
35. A method of determining which microorganism is present in a biological sample which contains a microorganism, wherein said method comprises the steps of:
 - (a) concentrating said microorganism according to the method of claim 11;
 - (b) recovering the microorganism in a concentrated form
 - (c) subjecting said microorganism to mass spectroscopy to measure the masses of individual proteins;
 - (d) determining a mass spectrum of said sizes of proteins;
 - (e) comparing said mass spectrum of proteins with mass spectra obtained using known microorganisms; and
 - (f) determining that the microorganism in said biological sample is the same as a known microorganism which yields a mass spectrum identical with the mass spectrum obtained for the microorganism from said biological sample.
36. The method of claim 35, wherein said mass spectrometry is matrix assisted laser desorption ionization time of flight mass spectrometry.
37. The method of claim 35, wherein said mass spectrometry is electrospray mass spectrometry.

38. The method of claim 35, wherein said proteins are enzymatically digested prior to obtaining a mass spectrum.
39. A method of determining which microorganism is present in a biological sample which contains a microorganism wherein said method comprises the steps of:
- (a) concentrating said microorganism according to the method of claim 11, to yield concentrated microorganism;
 - (b) extracting nucleic acid from said concentrated microorganism;
 - (c) incubating said nucleic acid with restriction enzymes to produce nucleic acid fragments;
 - (d) staining said nucleic acid or nucleic acid fragments;
 - (e) determining a pattern of sizes of said nucleic acid fragments; and
 - (f) comparing said pattern of sizes with patterns of sizes of nucleic acids, digested with said restriction enzymes, obtained from known microorganisms,
- wherein said microorganism in said biological sample is identified as a microorganism which has an identical restriction fragment pattern.
40. The method of claim 39, wherein said sizes of nucleic acid molecules or fragments thereof are determined using flow cytometry.
41. The method of claim 39, wherein said sizes of nucleic acid molecules or fragments thereof are determined by gel electrophoresis.
42. The method of claim 39, wherein said sizes of nucleic acid molecules or fragments thereof are determined by mass spectrometry.
43. The method of claim 39, wherein said size of nucleic acid molecules or fragments thereof are determined by optical mapping.
44. A method of determining the mass of a microorganism genome of a microorganism in a biological sample wherein said method comprises the steps of:
- (a) concentrating said microorganism by the method of claim 11;

- (b) staining said microorganism genome;
 - (c) purifying said microorganism genome; and
 - (d) subjecting said microorganism genome to fluorescence flow cytometry.
45. The method of claim 44, wherein said microorganism genome is digested with restriction enzymes prior to step (d).
46. A method of identifying a microorganism in a biological sample, wherein said method comprises the steps of:
- (a) concentrating said microorganism according to the method of claim 11; and
 - (b) incubating with antibodies specific for known microorganisms,
- wherein if said antibodies bind to said concentrated microorganism then said microorganism is identified as the microorganism to which the antibodies are known to bind, by their fluorescence.
47. The method of claim 46, wherein said fluorescent antibodies are present in said upper region of said centrifuge tube during centrifugation of said biological sample, attach to the microorganism for which they are specific during incubation, cosediment and coband with said microorganism, and are detected by the fluorescence of said antibody-microorganism conjugate band.
48. The method of claim 47, wherein a plurality of species of antibody is present in said upper region of said centrifuge tube during centrifugation of said biological sample and wherein each species of antibody is labeled with a marker distinct from any marker on any other species of antibody present in said upper region.
49. The method of claim 46, in which the antibody microorganism complex has a banding density different from that of the free microorganism, thus allowing the presence of the complex to be detected.

50. A method of separating layers in a centrifuge tube prior to centrifugation wherein fluid in said centrifuge tube comprises a first dense layer and a second less-dense layer, wherein said method comprises the steps of:
- (a) inserting said first dense layer into said tube;
 - (b) providing a means for separating the first and second layers; and
 - (c) inserting said second less-dense layer into said tube,
- wherein said centrifuge tube comprises an upper region, a middle region and a lower region, wherein an inner diameter of said upper region is larger than an inner diameter of said middle region and wherein an inner diameter of said middle region is larger than an inner diameter of said lower region.
51. The method of claim 50, wherein said means for separating said layers is an air bubble.
52. The method of claim 50, wherein said means for separating said layers is a porous disk and said porous disk is inserted on top of said first layer.
53. The method of claim 52, wherein said disk floats during centrifugation to a region above said second less-dense layer, thereby allowing said first dense layer to contact said second less-dense layer.
54. The method of claim 52, wherein said disk is made of sintered polyethylene or polypropylene.
55. The centrifuge tube of claim 1, wherein said centrifuge tube is prepared from materials such that said tube can be centrifuged at velocities high enough to band microorganisms in CsCl gradients without said centrifuge tube breaking.
56. The centrifuge tube of claim 55, wherein said tube is made of polycarbonate.
57. The centrifuge tube of claim 1, wherein said upper region, middle region, and said lower region have outer diameters equal to each other.

58. The centrifuge tube of claim 1, wherein said upper region has an outer diameter larger than an outer diameter of said lower region.
59. The method according to claim 11, wherein said centrifuge tube is supported by an adapter with inner dimensions contoured to match said centrifuge tube's outer dimensions.
60. The method according to claim 59, wherein said adapter is manufactured from polycarbonate or Delrin®.
61. A system for measuring fluorescence from a sample in a centrifuge tube wherein said system comprises:
- a centrifuge tube holder to hold a centrifuge tube in a vertical position;
 - a laser which produces a laser beam;
 - a filter for isolating light of one wavelength;
 - a filter through which passes light emitted by excited dye bound to said sample which has been banded in a centrifuge tube when said centrifuge tube is placed into said centrifuge tube holder; and
 - a detector which detects light passing through the filter of part (c).
62. The system of claim 61, comprising in addition
- goniometers onto which said centrifuge tube holder is mounted thereby enabling a centrifuge tube which is in said centrifuge tube holder to be oriented to match the vertical angle of the laser beam;
 - an X-Y movement to align the tubes with the laser beam in any X-Y direction;
 - a filter through which said laser beam passes; and
 - a mirror to deflect said laser beam through a centrifuge tube held in said centrifuge tube holder.
63. The system of claim 61, further comprising a computer.
64. The system of claim 63, further comprising a monitor.

65. The system of claim 64, wherein said monitor is a cathode ray tube.
66. A system for measuring fluorescence from a sample in a centrifuge tube wherein said system comprises:
- a holder for said centrifuge tube;
 - a light source to produce light which will pass through said sample; and
 - a detector to detect light which is emitted from said sample upon having light passed through it.
67. The system of claim 66, further comprising:
- a condensing lens through which said light from said light source passes;
 - a filter through which said light from said light source passes;
 - an intensity equilibrators through which said light passes;
 - light pipes through which said light passes; and
 - two intensity equilibrators through which light leaving said light pipes passes.
68. The system of claim 67, further comprising:
- an emission filter through which light emitted from said sample passes.
69. The system of claim 67, wherein said filter is replaced by a filter wheel comprising more than one filter.
70. The system of claim 67, further comprising:
- a filter wheel comprising more than one emission filter wherein any one emission filter of said filter wheel can be placed between light emitted from said sample and said detector.
71. The system of claim 66, further comprising a computer.
72. The system of claim 71, further comprising a monitor.
73. The system of claim 72, wherein said monitor is a cathode ray tube.

74. A system for counting particles which are concentrated in a small volume, wherein said system comprises:
- a container in which said particles are concentrated;
 - a capillary tube;
 - a first pump and a second pump;
 - means for moving said container relative to said capillary tube;
 - a flow cell;
 - a light source; and
 - a detector.
75. The system of claim 74, wherein said first pump pumps fluid into a sheath around an upper end of said capillary.
76. The system of claim 75, wherein said second pump pumps fluid out of said flow cell.
77. The system of claim 76, wherein said second pump pumps more fluid in a given time period than said first pump.
78. The system of claim 77, wherein fluid is drawn through a lower end of said capillary tube, said fluid exits said upper end of said capillary tube where it is surrounded by fluid pumped from said first pump, and wherein said second pump pumps the mixture of fluid exiting from said upper end of said capillary tube and said fluid from said first pump through said flow cell.
79. The system of claim 78, wherein said light source produces a light beam which passes through said flow cell.
80. The system of claim 79, further comprising:
- a filter between said light source and said flow cell.
81. The system of claim 80, further comprising:
- a filter between said flow cell and said detector.

82. A method of determining the size of a genome of a microorganism in a biological sample, wherein said method comprises the steps of:
- (a) concentrating said microorganism by the method of claim 11, to produce concentrated microorganism;
 - (b) extracting said genome from said concentrated microorganism to produce extracted nucleic acid;
 - (c) immobilizing said extracted nucleic acid on a solid support;
 - (d) staining said extracted nucleic acid; and
 - (e) electronically imaging said extracted and stained nucleic acid on said solid support using an epifluorescence microscope, and
 - (f) measuring the length of individual nucleic acid molecules.
83. A method for determining a restriction enzyme map of a microorganism, wherein said method comprises the steps of:
- (a) concentrating said microorganism by the method of claim 11, to produce concentrated microorganism;
 - (b) extracting said genome from said concentrated microorganism to produce extracted nucleic acid;
 - (c) staining said extracted nucleic acid;
 - (d) immobilizing said extracted nucleic acid on a solid support to produce immobilized nucleic acid;
 - (e) treating said immobilized nucleic acid with one or more restriction enzymes; and
 - (f) determining the number of fragments of nucleic acid and the lengths of nucleic acid fragments produced.
84. A method for determining the identity of a microorganism in a biological sample, wherein said method comprises the steps of:
- (a) determining a restriction map according to the method of claim 83; and
 - (b) comparing said restriction map to restriction maps of known microorganisms, wherein a match of restriction maps of said microorganism in said biological sample with a restriction map of a known microorganism identifies the microorganism of

said biological sample as being that of said known microorganism with an identical restriction map as that of the microorganism of said biological sample.

85. A method for distinguishing the type of infection between virus, mycoplasma, yeast and bacterial infections by determining the presence of a virus, mycoplasma, yeast or bacteria in a biological sample, which comprises the steps of:
- (a) concentrating said microorganism by the method of claim 11, to produce concentrated microorganism;
 - (b) staining the microorganism with a fluorescent dye;
 - (c) measuring the amount of nucleic acid in the stained, concentrated microorganism, and
 - (d) comparing the amount of said nucleic acid to the known amount of nucleic acid for viruses, mycoplasmas, yeast and bacteria.
86. The method of claim 85, wherein the microorganism is stained during centrifugation.
87. The method of claim 85, wherein the microorganism is stained in the biological sample.
88. The method of claim 85, wherein the amount of nucleic acid is measured by flow cytometry.
89. The method of claim 85, wherein the amount of nucleic acid is measured by optical mapping.
90. The method of claim 29, in which the changes in the titre of an infectious agent are used to determine which known pharmacological agents are therapeutic, to evaluate the efficacy of new drugs in animal and human trials, and to choose between analogues of drugs in development.
91. The method of claim 29, in which the changes in the titre of an infectious agent are used to discover new antibiotics and other therapeutic agents.

FIG. 1

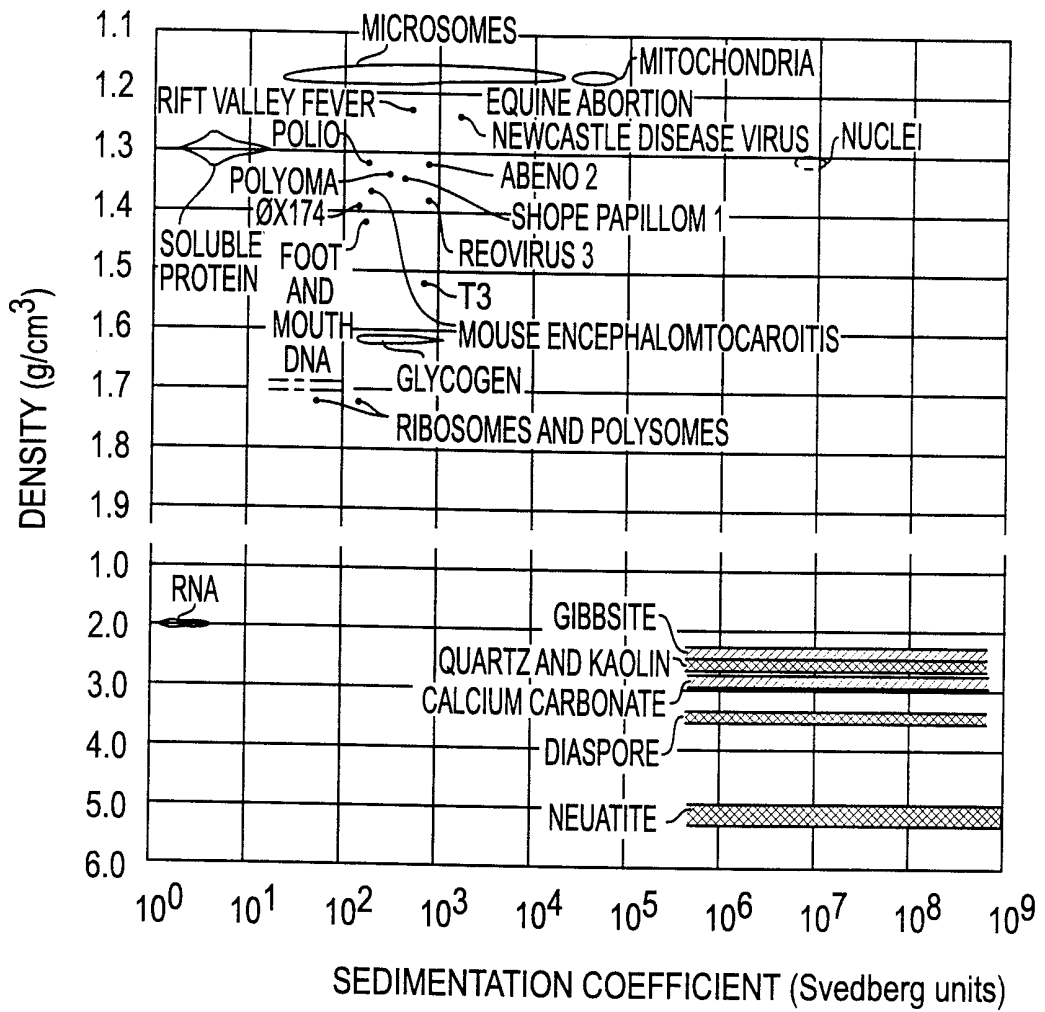

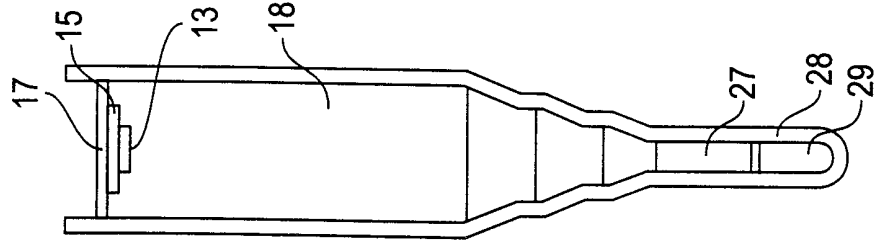

FIG. 2C

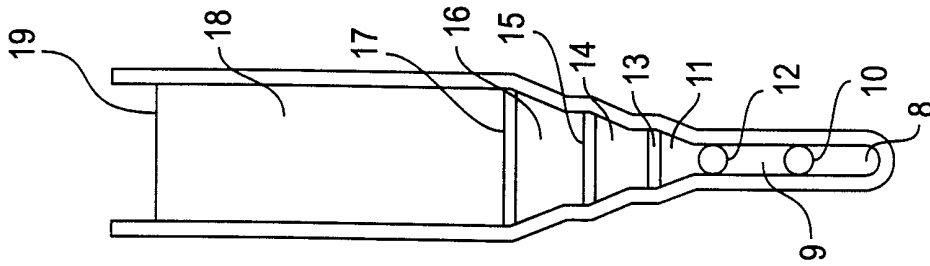

FIG. 2B

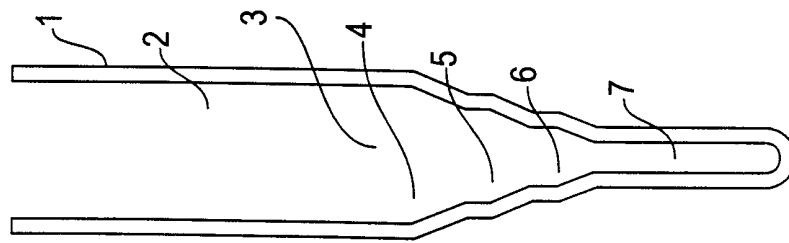

FIG. 2A

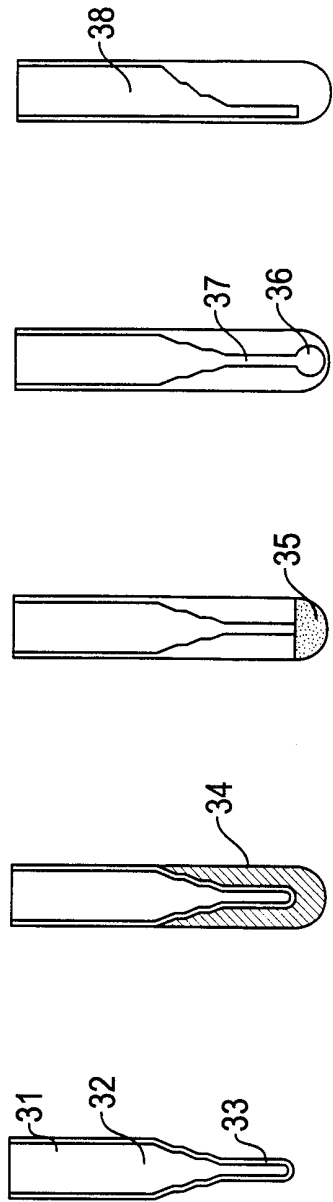

FIG. 3A FIG. 3B FIG. 3C FIG. 3D FIG. 3E

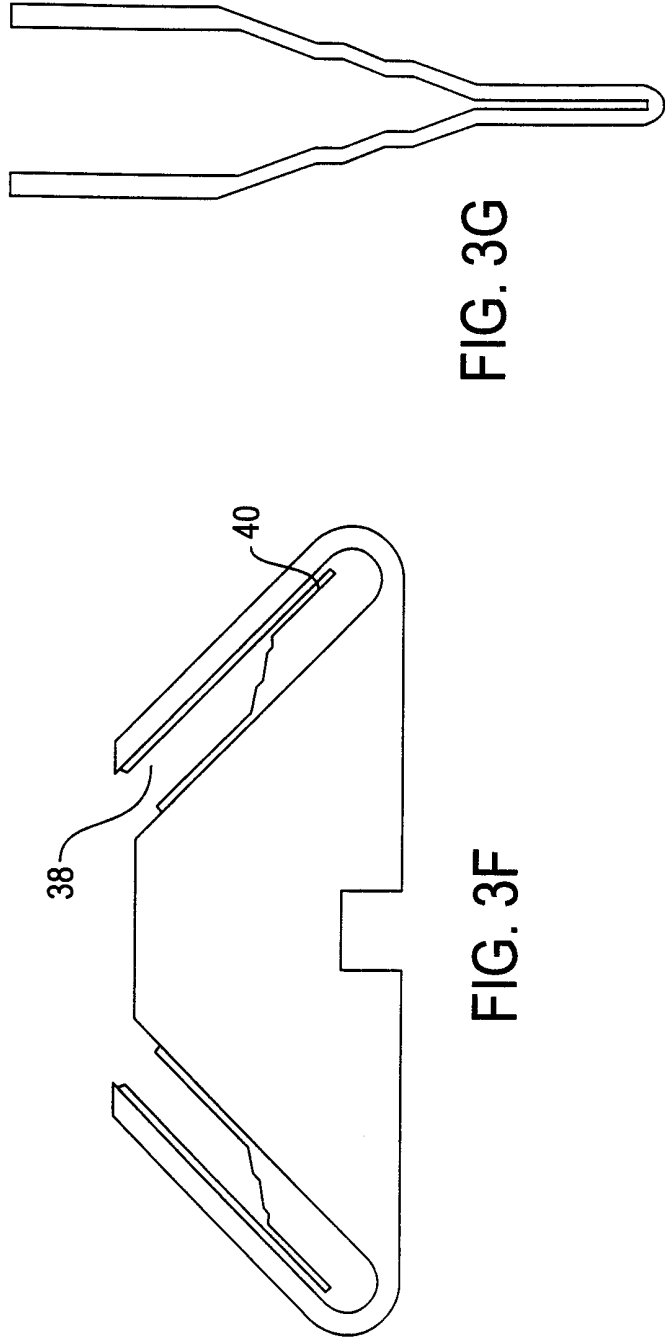

FIG. 3G

FIG. 3F

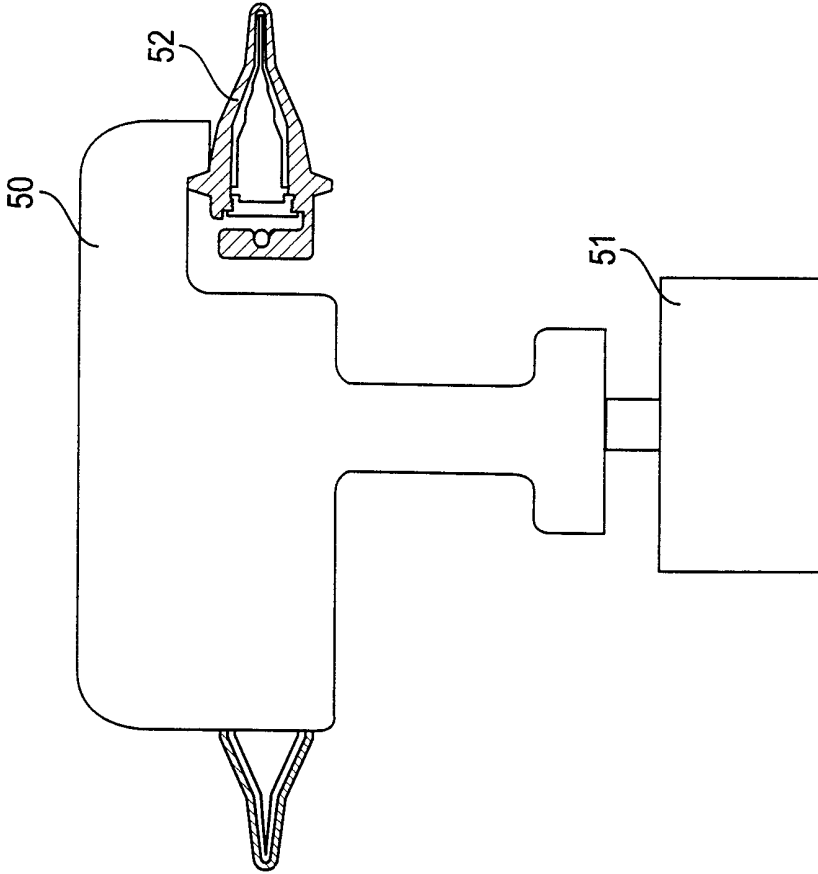

FIG. 4B

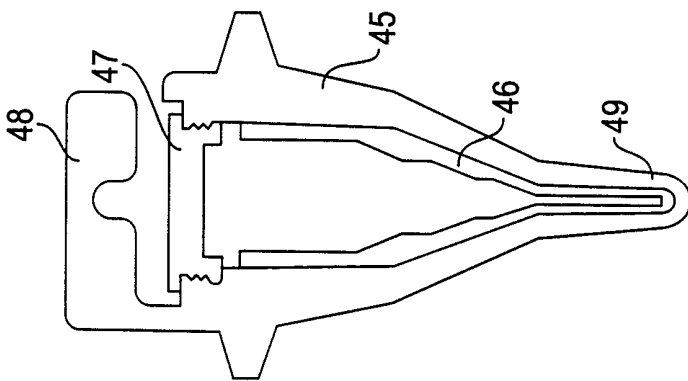

FIG. 4A

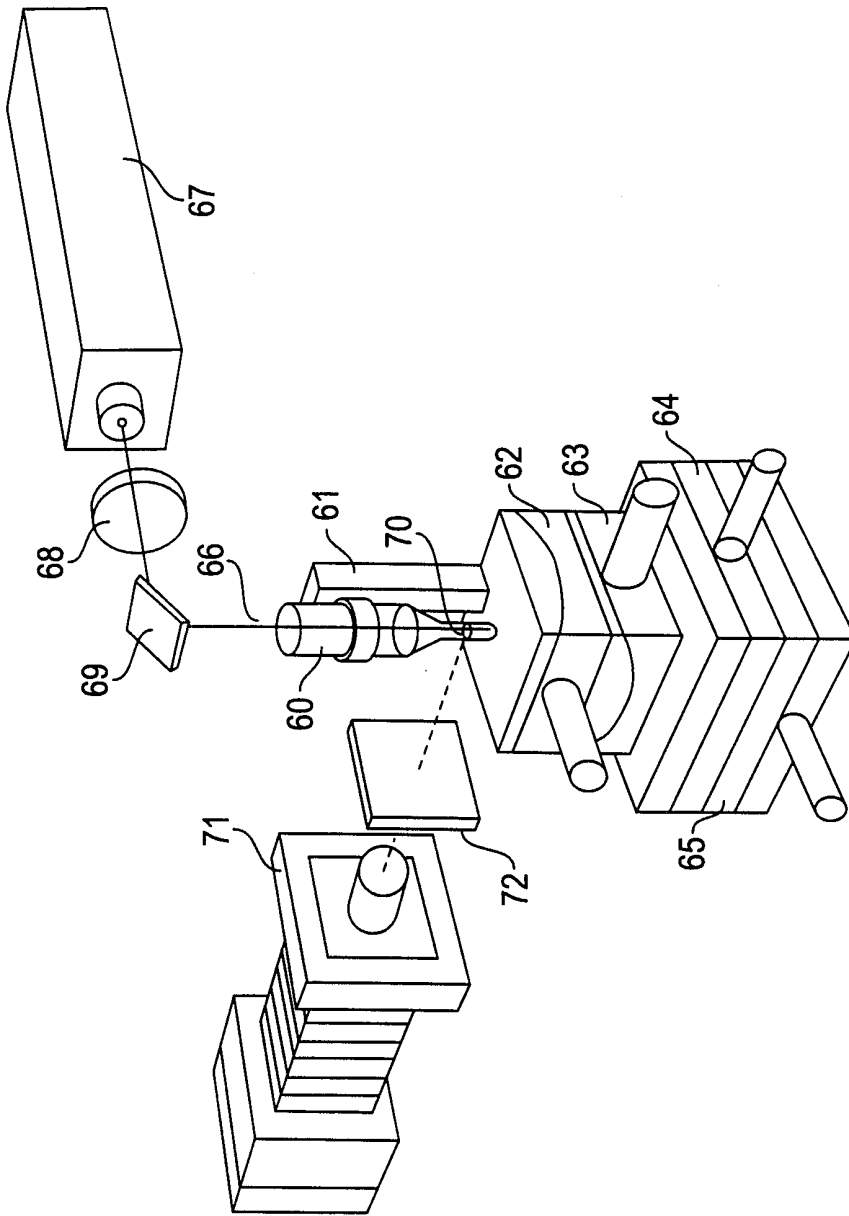

FIG. 5

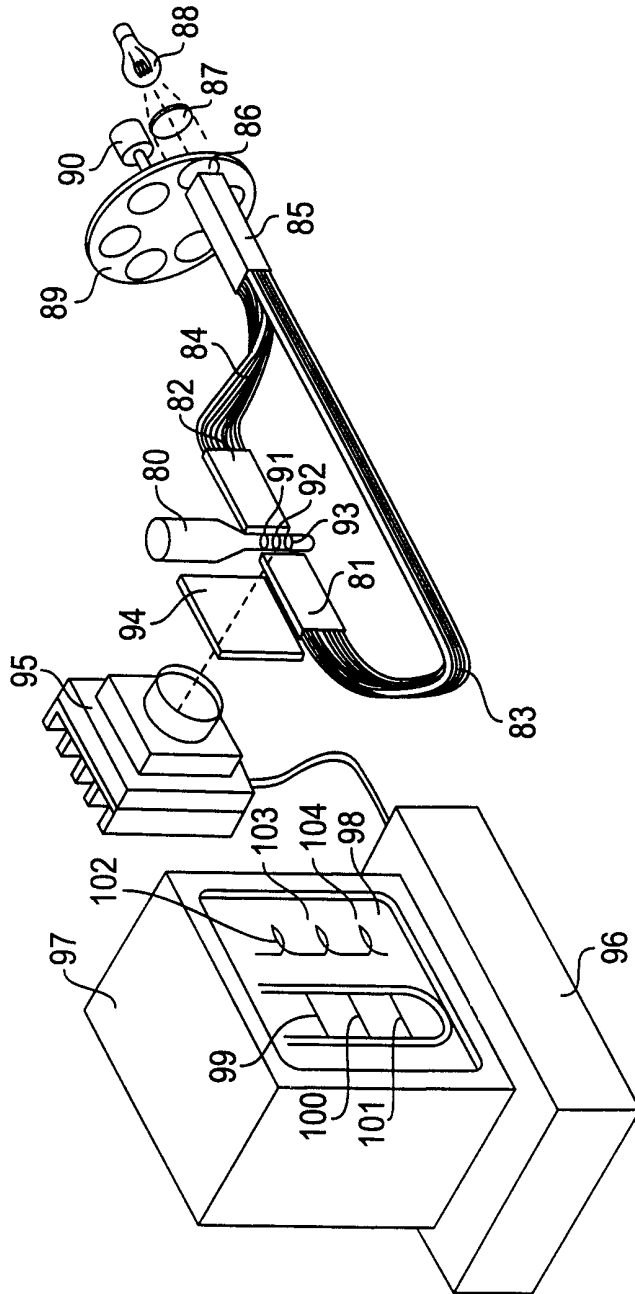

FIG. 6

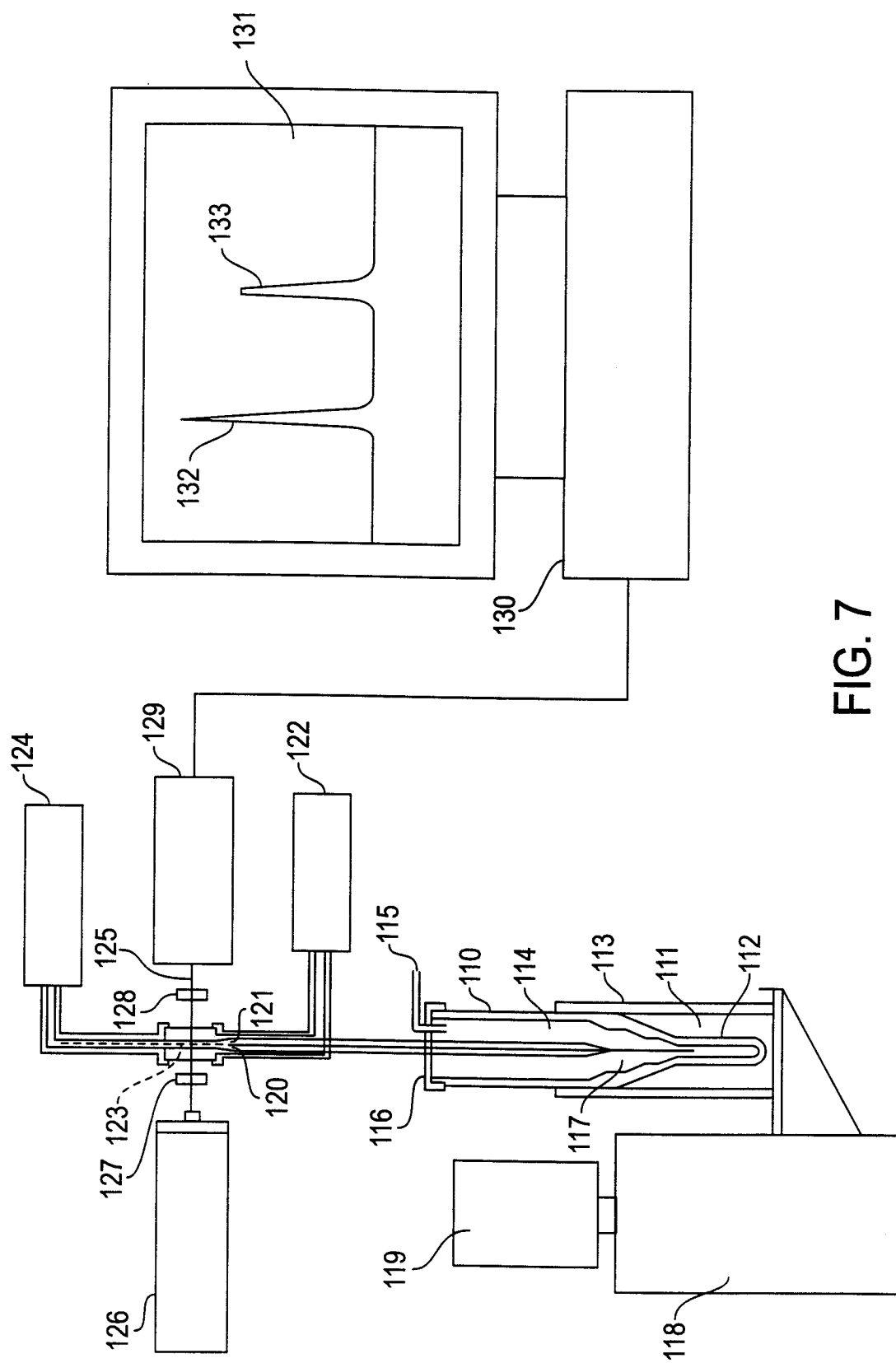

FIG. 7

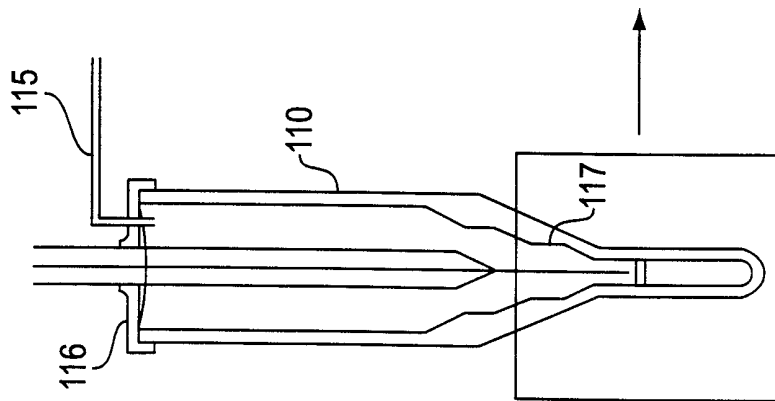

FIG. 8A

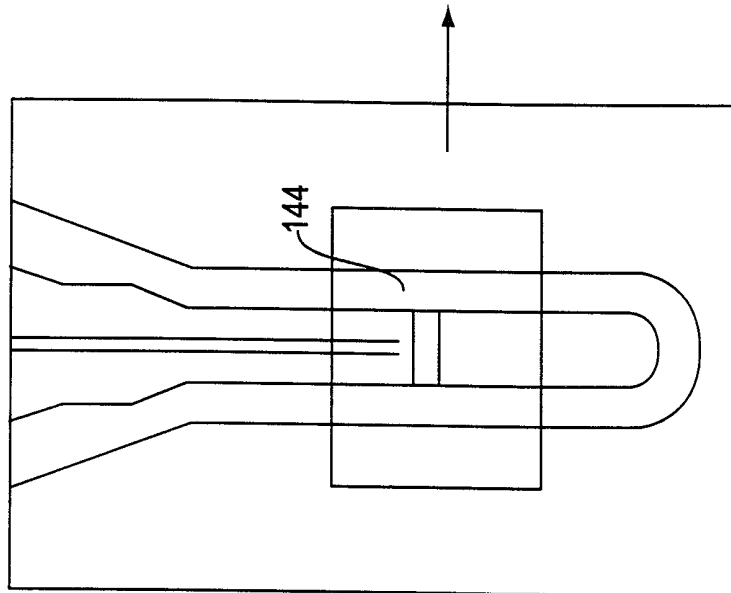

FIG. 8B

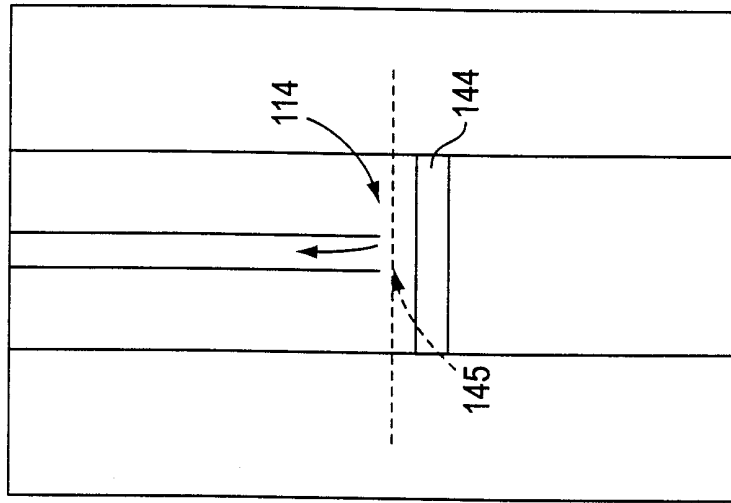

FIG. 8C

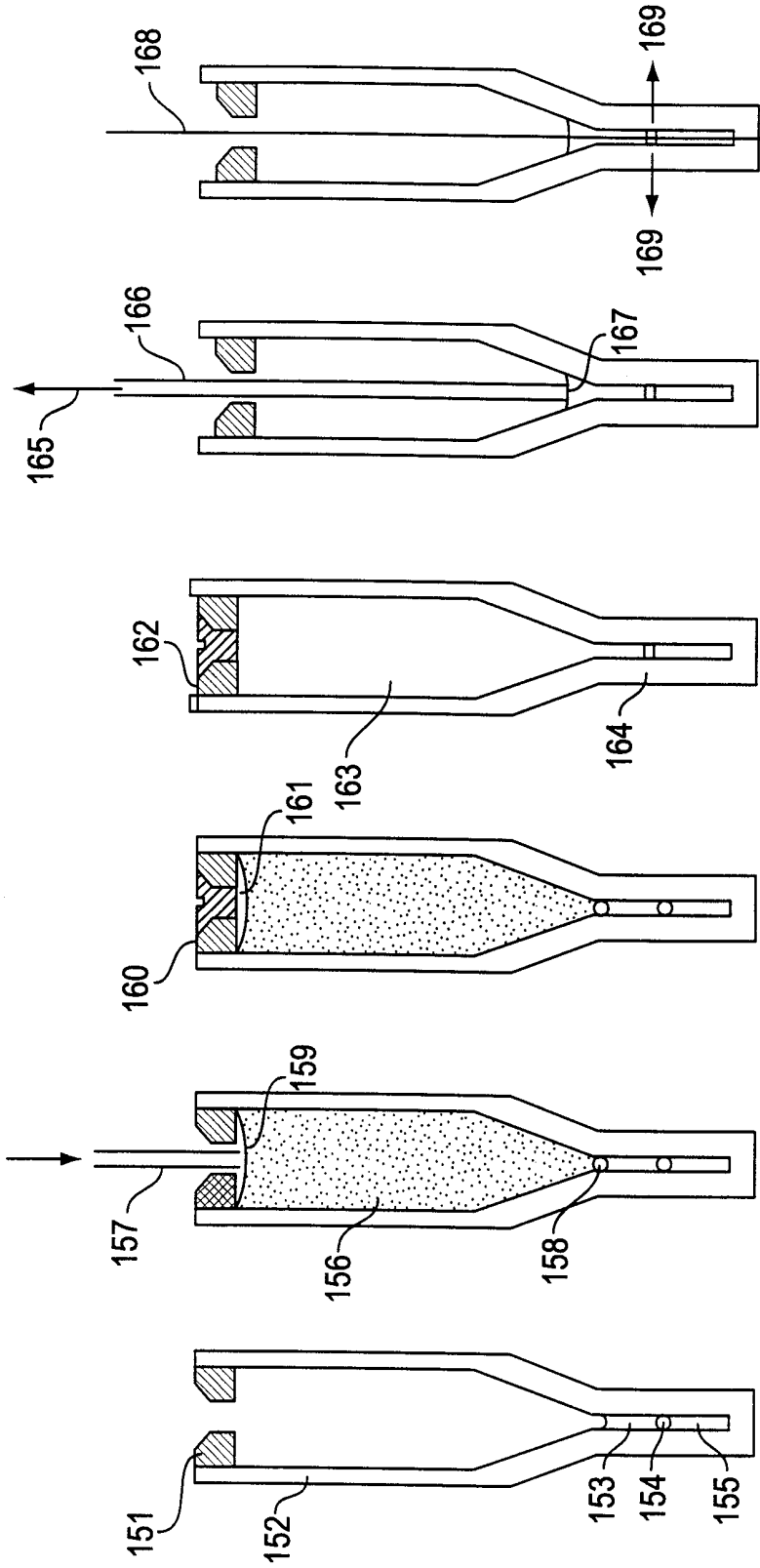

FIG. 9A FIG. 9B FIG. 9C FIG. 9D FIG. 9E FIG. 9F