

|      |   |           |        |               |          |
|------|---|-----------|--------|---------------|----------|
| [54] | JACQUARD PATTERN DRUM WITH<br>REMOVABLE PATTERN HOLDING<br>ELEMENTS   | 168,671   | 3/1904 | Germany       | 139/334  |
|      |   | 83,420    | 8/1971 | Germany       |          |
|      |   | 1,578,629 | 8/1969 | France        | 66/50 B  |
|      |   | 284,381   | 4/1931 | Italy         | 66/156   |
| [75] | Inventors: <b>Wolfgang Mühlhäusler</b> , Tübingen;<br><b>Hermann Vollmer</b> , Rottenburg, both<br>of Germany | 760,020   | 3/1930 | Sweden        | 66/154 R |
|      |   | 1,166,430 | 8/1968 | Great Britain | 66/156   |

[73] Assignee: **Fouquet-Werk Frauz & Planck**,  
Rottenburg am Neckar, Germany

[22] Filed: **June 12, 1972**

[21] Appl. No.: **261,708**

[30] **Foreign Application Priority Data**  
June 21, 1971 Germany..... 2130620

[52] **U.S. Cl.**..... **66/50 B, 66/156**  
[51] **Int. Cl.**..... **D04b 15/66**  
[58] **Field of Search**..... **66/154 R, 50 B, 156, 50 R,**  
**66/25, 75**

[56] **References Cited**

**UNITED STATES PATENTS**

|           |         |                     |          |
|-----------|---------|---------------------|----------|
| 67,263    | 7/1867  | Carey.....          | 66/154 R |
| 262,466   | 8/1882  | Parr.....           | 66/156   |
| 1,722,989 | 3/1926  | Ames.....           | 66/50 B  |
| 3,004,413 | 10/1961 | Felker.....         | 66/50 B  |
| 3,006,174 | 10/1961 | Haddad.....         | 66/156   |
| 3,093,987 | 6/1963  | Zahradka et al..... | 66/154 R |
| 3,344,620 | 10/1967 | Saunders.....       | 66/156   |
| 3,530,688 | 9/1970  | Lombardi.....       | 66/57    |
| 3,712,084 | 1/1973  | Falk Kuhn.....      | 66/156   |

**FOREIGN PATENTS OR APPLICATIONS**

|         |        |         |
|---------|--------|---------|
| 424,883 | 2/1926 | Germany |
|---------|--------|---------|

*Primary Examiner*—W. C. Reynolds  
*Assistant Examiner*—Andrew M. Falik  
*Attorney, Agent, or Firm*—Flynn & Frishauf

[57] **ABSTRACT**

A drum-like stem body structure which has a base and which is arranged for indexed rotation has placed thereon a group of separable holding bars, circumferentially around the outside of the drum, the holding bars themselves being formed with Jacquard control pins or projections of similar nature to control the camming elements for movement of the control butts of Jacquard selectors; the bars may also hold Jacquard programming jacks with selectively placed butts. The bars may be made of plastic, and are readily removable, for example by being snapped out of a crown ring, for separate storage of the bars, including the program thereon as defined by the control pins apart from the Jacquard selector drums themselves. The bars are held in locked engagement with each other by tongue and groove means formed on their opposite side surfaces.

**11 Claims, 15 Drawing Figures**

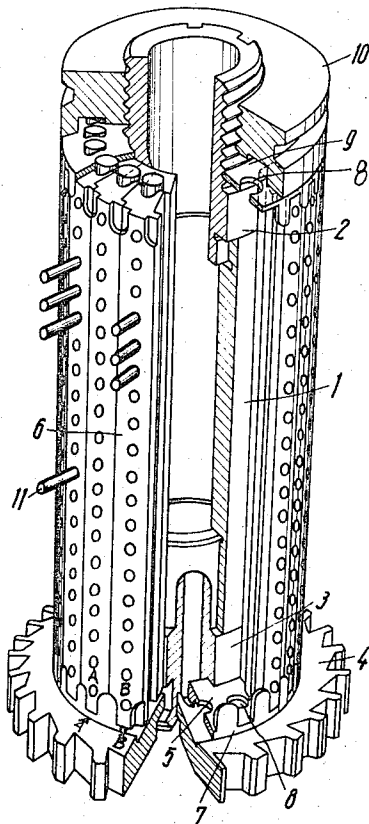
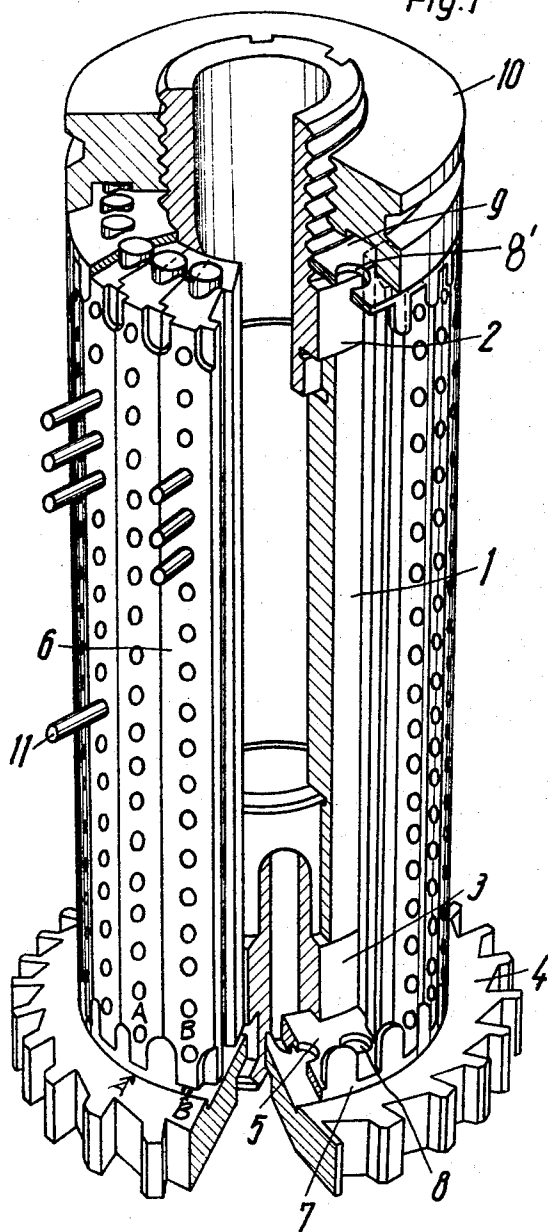
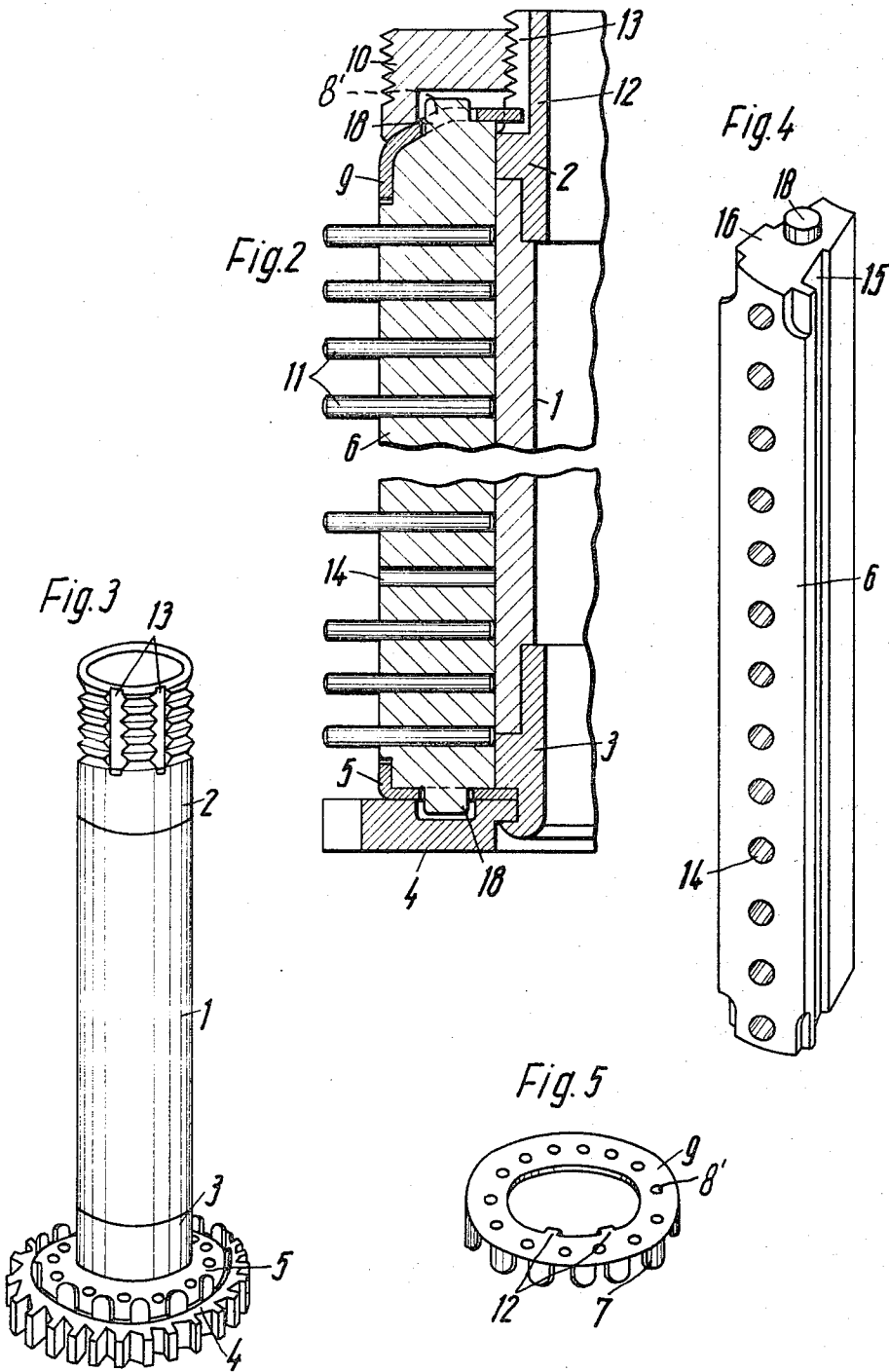
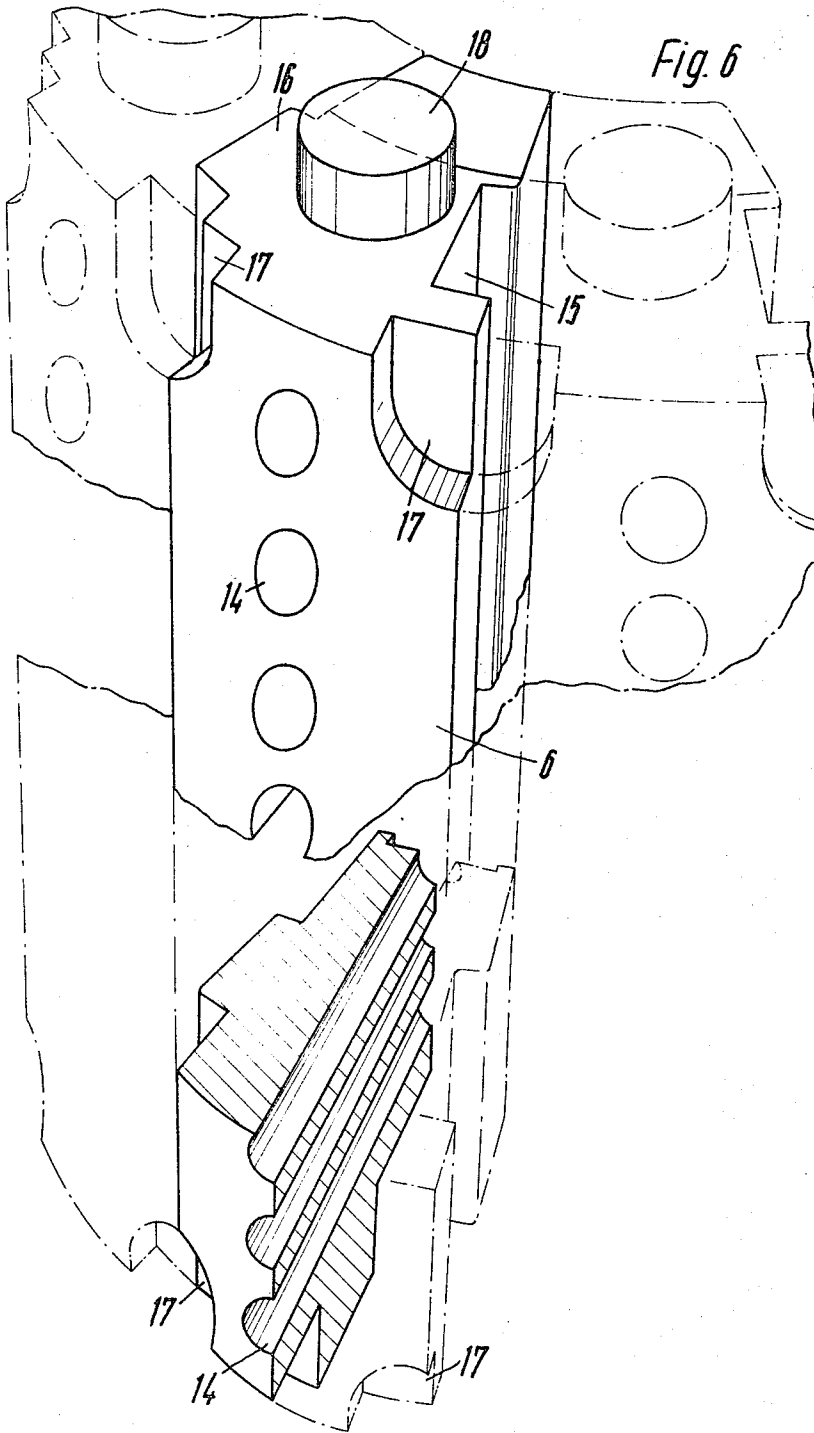
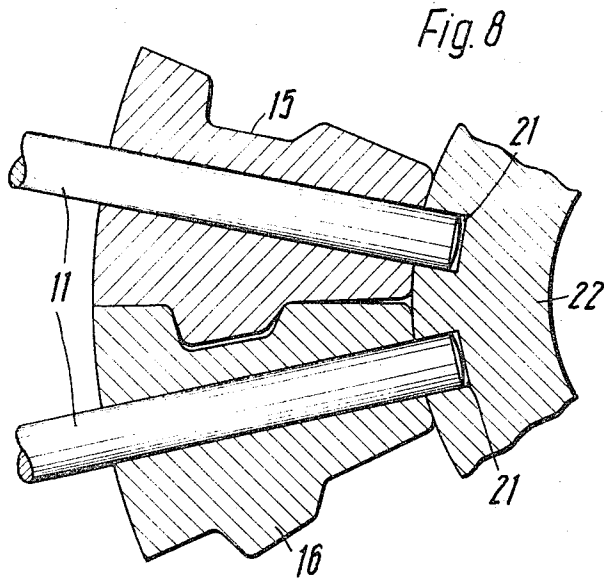
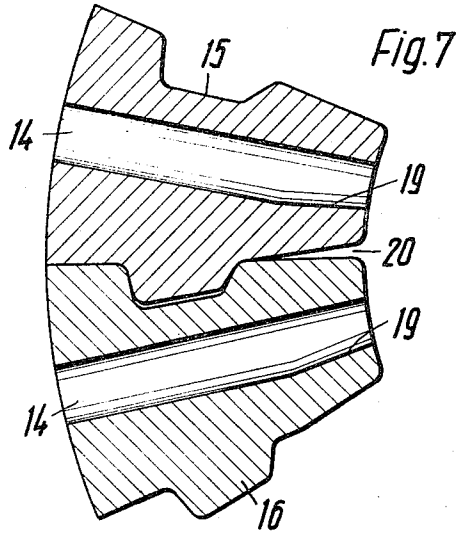


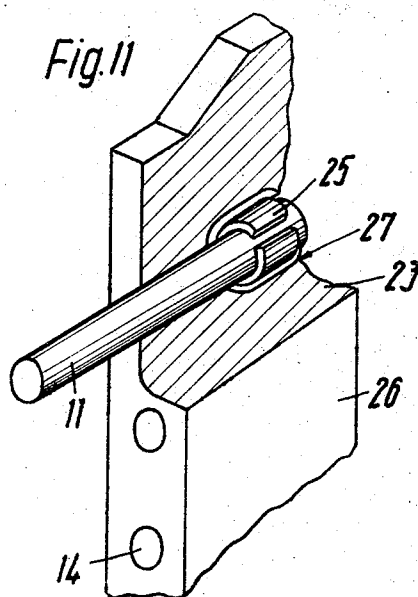
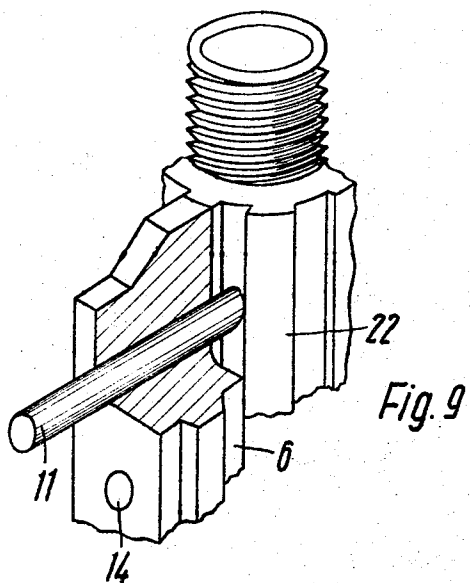
Fig. 1

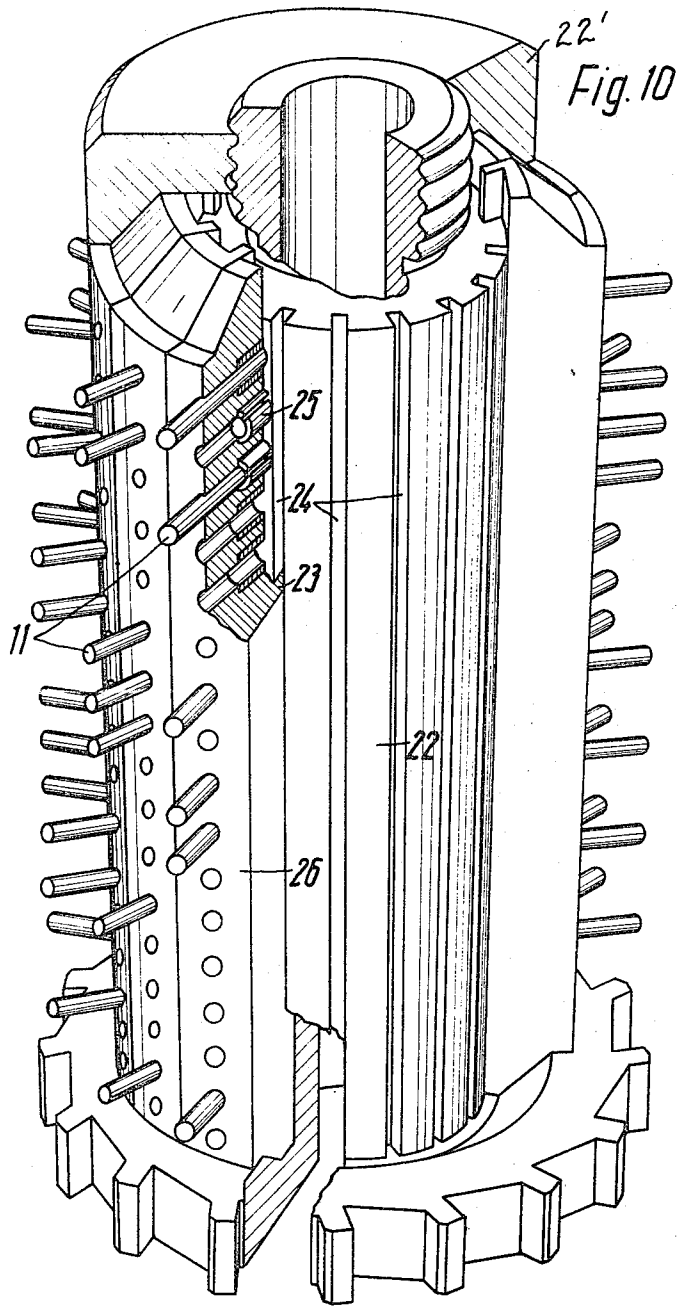


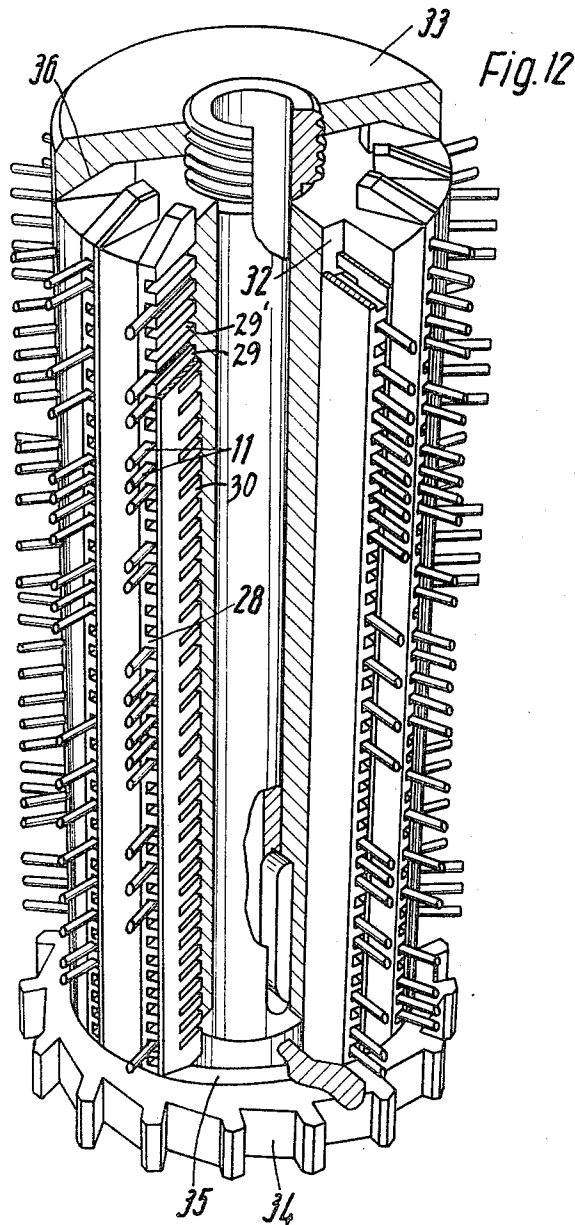












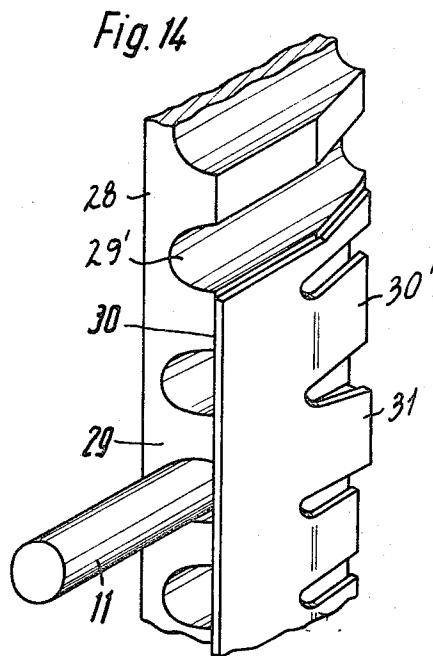
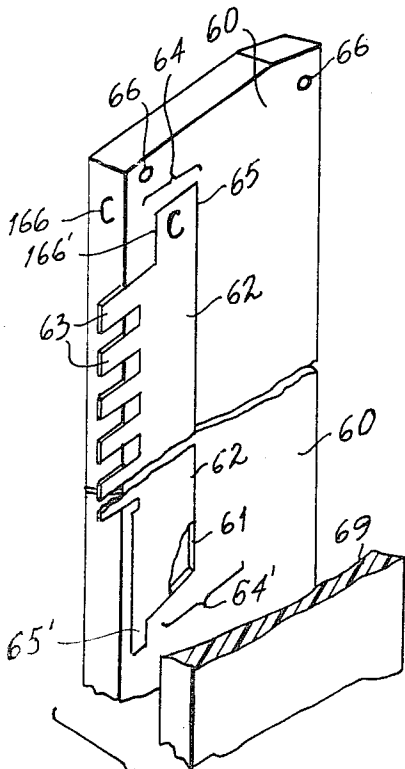
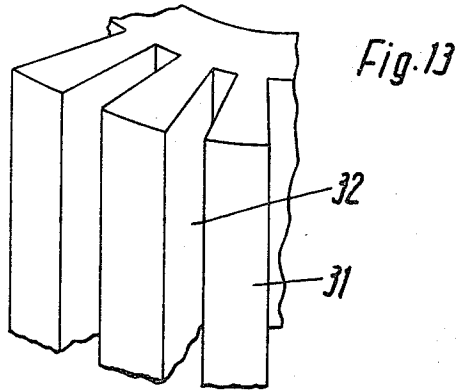


Fig. 15

## JACQUARD PATTERN DRUM WITH REMOVABLE PATTERN HOLDING ELEMENTS

Cross reference to related U.S. Pat. No. 3,712,084, assigned to the Assignee of the present application.

The present invention relates to Jacquard pattern control drums, particularly for circular knitting machines.

Circular knitting machines customarily store a pattern program on a patterning drum. These drums transfer the program, as determined by selector butts, to the knitting elements themselves. Usually, intervening positioning cams are located to prevent direct contact between selector elements on the Jacquard selector drum and control butts on Jacquard selector jacks of the knitting machine itself.

In one form, the Jacquard drums are indexed, in stepped rotation with rotation of the knitting machine, for example by ratchet wheels, sprocket chains or the like. The drums thus rotate in predetermined intervals synchronized with the machine, and then stop, during which stopped period the selection is effected. The position of projecting elements from the drum is sensed by sensing levers or cam elements which transfer the information obtained from the drum, that is, whether in predetermined levels there are projections from the drum or not, in order to control the needle selector jacks in appropriate manner, and thus to transfer the pattern stored on the selector drums to the needles themselves.

Jacquard selector drums carrying patterns are provided in various types. In one example, a drum-like body structure is formed with longitudinal grooves into which selector jacks are inserted. These selector jacks are longitudinal lamellae of steel, which have projecting comb-like butts extending therefrom. Selected butts, at selected positions are broken out, to thereby control the pattern which is to be knitted, and the jacks, with the selectively broken-out butts are inserted into the drum-like body. Similarly, round disks of steel have been proposed which serve as pattern controllers; the disks have teeth at their outside which are also selectively present or absent, in order to control the pattern of the machine.

After the pattern selector jacks, or disks have their butts, or teeth, respectively, selectively removed, it is possible to re-use the butts or wheels only to a very limited extent, namely, when the pattern would call for removal of all the already removed butts or teeth; usually, however, it is simpler to make a new selector jack or wheel entirely.

In a different form of selector, a drum, or wheel-like selector carrier is provided at its circumference with openings into which pins are either inserted or not, depending upon the pattern which is desired to be knitted. These drums can be re-used many times, and the pins merely removed or re-inserted as desired.

A knitting plant usually has two or more sets of drums with pins therein for each knitting machine. If a pattern which is to be knitted once is to be reproduced, it is simple to merely replace the knitting drums with the pins thereon, rather than to re-program another set of drums (and one is necessary for each knitting feed), and to check the newly programmed drums for errors and mistakes. Storing complete sets of Jacquard selector drums with the pins thereon is, however, wasteful since the drums require a substantial space for their

storage. Additionally, the drums are precision elements and comparatively expensive, due to their accurately synchronized cooperation with the knitting machine, so that holding expensive items of this kind in storage is uneconomical. Further, the drums are usually made of ferrous metal, so that precautions against oxidation and deterioration must be made. It has not been found possible to make the drums of a material which is lighter and less subject to atmospheric or other attack, since the bores for the control pins for the drums have to be very accurately located, and accurately sized. One drum may have a thousand or more such bores.

It has previously been proposed to reduce the weight and complexity of the control elements of the Jacquard controllers by utilizing light metal or plastics. It is difficult, however, to form the bores with sufficient accuracy and to hold the pins in bores, which may not be as accurate as desired, under the forces of vibration and centrifugal force arising during operation of the machine. It has not been found possible to make pattern controllers by injection molding, pressure casting, die-casting or the like, due to the final accuracy desired, unless casting molds are prepared which are so accurate and are so formed with many star-shaped projections and inserts to form the bores, that the costs of the molds themselves become excessive, resulting in an eventually produced cost of the Jacquard pattern carriers which likewise is excessive.

It is an object of the present invention to provide a pattern carrier, particularly a drum-shaped pattern carrier which permits use of inexpensive material, and which permits ready use of storage of a once programmed pattern.

### Subject matter of the present invention

Briefly, a body structure having a drum-like stem is provided, on which at least two separate holding bars are located, extending part-circumferentially around the drum-like stem. The holding bars are secured to the stem with respect to a certain datum, to be rotatable therewith, and to locate the bars in predetermined position on the body structure with respect to the radial datum. Projecting control elements, such as pins are inserted into the holding bars radially. The control elements are held in the openings frictionally, or by an interference fit, preferably resiliently. The bars themselves may be made of plastic, and are secured, in fixed position on the drum, for example by means of a star base and a similarly shaped crown which, together with the bars, provides for matching recesses and projections to hold the bars in position around the central stem.

If the pattern carrier is a wheel, for example a multi-tiered wheel, disks can be placed on top of each other, stacked on the drum, the disks themselves being ring-shaped having the openings formed at the outside thereof and similarly engaging the drum-like stem, the disks being located with respect to the stem by engaging matching grooves and ribs formed on the drum and disks, respectively.

A patterning drum in accordance with the invention permits removal of the bars from the actual Jacquard pattern carrier body structure. The bars can then be placed, flat, next to each other and spread out and individually inserted in suitable plastic pockets, to be rolled up, similar to a plastic carrier for wrenches or other longitudinal tools or the like. The pattern can always be

reconstituted by merely inserting the strips or bars into any other convenient pattern carrier. It is a simple matter to mark the patterns with index numbers or letters, and to group the bars together. If a certain pattern has been knitted and it is desired to change the aspect of the pattern, bars can be replaced, or the cyclical sequence of selected bars interchanged, in order to obtain different patterns without completely reprogramming the entire machine, or without reprogramming the individual pattern bars or strips, with the pins therein themselves. Insertion of the bars with pins is simpler than placing Jacquard selector jacks and butts, due to the greater bulk and consequent ease of handling. The identification of the various bars is simple, and a pattern can readily be checked by spreading out a group of bars, adjacent each other, for ease of visual inspection to obtain an outline of all the bars as it would appear on a developed surface. Thus, errors can readily be detected by checking the flow of pattern of the pattern pins on the drums, which can all be seen simultaneously when spread out.

When made of plastic, the bars can be of different colors; a certain or fixed starting datum can have an outstanding color, for example red, whereas the other bars are neutral; various bars can be used with different contrasting colors to provide for ease of identification and supervision, thus also enabling checking of proper indexing of the Jacquard selector drums.

The invention will be described by way of example with reference to the accompanying drawings, wherein:

FIG. 1 is a perspective view, partly in section, of a Jacquard selector drum;

FIG. 2 is a fragmentary vertical section of the drum of FIG. 1;

FIG. 3 is a perspective view of the drum with the pattern carrier bars removed;

FIG. 4 is a perspective view of a carrier bar;

FIG. 5 is a perspective view of a holding crown ring;

FIG. 6 is a greatly enlarged perspective view, partly in phantom, illustrating the carrier bars and their cooperation;

FIG. 7 is a transverse cross-sectional view of a pair of adjacent carrier bars;

FIG. 8 is a transverse cross-sectional view of a pair of carrier bars with a drum of modified outer surface;

FIG. 9 is a perspective view, partly cut away, of the structure of FIG. 8;

FIG. 10 is a perspective partly cut-away, partly sectional view of another embodiment of the present invention, and showing a different arrangement of placement and locating of carrier bars, as well as of index pins;

FIG. 11 is a partly broken away perspective view showing the holding of selector pins;

FIG. 12 is a partly broken away perspective view illustrating another embodiment of holding bars to hold selector pins;

FIG. 13 is a fragmentary perspective view of another form of drum surface;

FIG. 14 is a fragmentary perspective view illustrating holding of selector pins by the bars of FIG. 12;

and FIG. 15 is a fragmentary perspective view, partly exploded, of a holding arrangement for selector jacks.

Referring first to FIGS. 1 to 7: a central stem 1 has an upper bearing portion 2, and a lower bearing portion 3, both fixedly secured to the stem 1 and to an index ratchet wheel 4, which is indexed under control of the knitting machine selector mechanism. A lower crown 5 is secured to stem 1 and hence to the ratchet or gear wheel 4. Stem 1, crown 5, and gear 4 form one unit which may, in short, be termed a body or base structure. This body structure has control bars 6 placed thereon which, in the form of the invention illustrated, are longitudinally, that is axially extending strips.

The strips are held in place by base star or crown wheel 5 and a top star or crown wheel 9. Both these crown wheels may be similar, and are formed with outwardly projecting tines 7, and with a group of holes 8, 8'. The bars are formed with recesses 17 (FIG. 6) and projections 18 on their top and bottom end portions, the recesses 17 being held by the tines 7, 9, respectively, and the projections 18 fitting into holes 8, 8'. In the form of the invention illustrated, the bars 6 can be placed against the stem body portion and will remain thereon, vertically, in position, the tines 7 holding them in place to permit assembly to be carried out easily, and to enable the top crown 9 to be slipped thereover to hold all the bars 6 in place. The base gear 4, as well as the bars, is formed with matching indicia such as letters A, B, etc., suitable numbers or other indicia, to provide for matching of the bars to specific positions on the base body. Color marks may also be used, and the bars similarly colored, particularly if made of plastic. If necessary, and in order to provide a complete circumference, spacer elements may be used, that is bars which do not have openings formed therein for reception of pins (as will appear below), but yet to provide for a circumferentially complete surface and to locate all the bars 6 in position.

When all the bars 6 have been placed, the upper crown disk 9 is placed over the bars, the tines 7 fitting into the upper recesses 17 of the bars. Thus, all the bars 6 are held in proper position. The entire assembly is then locked in place by means of a nut 10 (FIGS. 1, 2). The drum is now ready for insertion of pins to provide the Jacquard control pattern.

The body structure is formed with longitudinal grooves 13 (FIG. 2), into which projections 12 formed on the crown or star wheels 5, 9, engage (see FIG. 5). Thus, the crown or star wheels are secured against rotation with respect to the body structure, and are thus carried along as the body structure is rotatably indexed by the ratchet wheel 4. The bars 6 are taken along by engagement of the recesses 17 with the tines 7, 9 of the star or crown wheels. The bars 6 are preferably made of plastic material, but they may be made of other materials such as lightweight aluminum alloy made by pressure casting processes or the like. Making the bars of plastic is economical and fast, and results in bars which are extremely light-weight, inexpensive, and provide ready opportunity for selective coloring. Making the bars 6 in various colors, for example making the first bar A in red and the others in a uniform contrasting color, or each fourth bar (for a structure having bars divisible by four) with still another contrasting color, for example blue, provides rapid recognition of the pattern and ease of checking of the pattern location and pattern pins; further, when the bars are removed and placed, for example in a plastic carrier, next to each other, a clearly identifiable developed view of the

entire pattern carrier is obtained. The patterning itself can be facilitated, or indicated by the colors of the pattern carrier bars 6.

To set the pattern, the pattern bars 6 are formed with openings 14, into which pattern pins 11 are inserted. They are retained in the openings 14 by the elasticity of the surrounding material. Preferably, the bars are made of slightly elastic, slightly yielding plastic such as an acetal, for example "Delrin" (sold by DuPont); a nylon, such as "Ulramid" (sold by BASF) or polyphenyl oxide, such as "Noryl" (sold by General Electric Company). To facilitate introduction of the pins 11 into the opening 14, opening 14 preferably is made to taper slightly, that is, to be slightly greater in diameter forwardly than at the rear portion. When in working position, the pins are axially aligned and fit against the body stem — see FIG. 2. The length of the pins is accurately predetermined and therefore positive accurate location and projection of the pins can be obtained, by bearing against the accurately made circumference of body structure 1; the pins can still be accurately located although the holding elements for the pins themselves may be of inexpensive plastic material.

The side surfaces of the bars are formed with matching projections and grooves, so that the bars will interlock with each other. Thus, along the side of the bars a projection 16 (FIGS. 6, 7) engages in a matching groove 15 formed at the other side. This interlocking engagement of adjacent bars provides strength against radial deformation and removal when the pins 11 are pulled out from the openings 14 in which they are held by a friction fit. Nevertheless, if an entire bar is to be removed or re-assembled, it can readily be axially slid outwardly. In assembly, the bars are loosely held together and then snapped in position, or all bars, less one, are assembled by circumferential placement and the last one slid in axially.

FIG. 8 illustrates a modified form of body structure, in which the surface of the stem, as shown at 22, is formed with longitudinal grooves 21 into which the pins 11 can seat. This provides for additional stiffness of the entire assembled Jacquard pattern controller, and particularly prevents possible twisting deformation of the bars, that is, change in longitudinal axial position of the pins on the bars intermediate the ends thereof, where they are held in position by the end and crown disks 5 and 9. Grooves 21 preferably extend the length of the stem, in axial direction, and are so located that one axial groove 21 is associated with each bar, to permit all the pins 11 to engage in the grooves. The interior steps of the groove must be matched to the length of the pins 11. FIG. 7 illustrates, in greatly enlarged section, the interengagement of projections 16 and grooves 15, and additionally a simple and inexpensive way of frictionally holding the pins 11. One side of the bore 14 is narrowed at its inner end, as seen at 19. The adjacent side is slightly relieved, to leave a gap as seen at 20. As soon as the pin is inserted into opening 14 and through the constriction 19, the material of the bar 6 can deviate and take up the space of the relief 20 to completely fill in any otherwise free spaces. This solution is particularly adapted for bars of slightly deformable plastic material. This way of holding the pins can be combined with various embodiments, for example with the embodiment of FIGS. 1-6 or the stem 22 of FIGS. 8 and 9.

Referring now to FIGS. 10 and 11: the basic body structure is similar to that previously described, except that the bars shown at 26 are so shaped that they are formed with a longitudinal projection 23 engaging in matching grooves 24 formed on the surface of the body structure 22. The longitudinal rib 23 fitting into groove 24 ensures against twisting deformation of the bar 26, and additionally positions the bar in location on the body structure 22. In this embodiment it is not necessary to provide a separate base holding star wheel, and a crown holding wheel as in the previous embodiments and the bars 26 can be inserted in a small depression formed in the base (see FIG. 10) adjacent each other. The lateral tongue-and-groove interconnection of the bars also is no longer necessary, particularly if the top of the bar is shaped as shown in FIG. 10 to be locked together by a top nut 22'.

The pins 11 are retained in the bars not by elastic deformation of the bar material 26 itself but rather, as best seen in FIG. 11, by an inserted spring sleeve 25. This embodiment of holding the pins 11 is particularly suitable if the bars 26 are made of non-elastic material, such as pressure cast or die-cast metal, such as aluminum, magnesium or the like. A spring sleeve 25 is inserted into a slightly enlarged back portion of the opening 14 formed in the bar. The inner diameter of the spring sleeve 25, in ordinary normal condition, is just slightly less than the outer diameter of the pins 11. Upon insertion of the pins, the sleeve 25 can expand, as seen in FIG. 11, to frictionally engage the pin 11. The sleeves 25 themselves are held in position in the bars 26 by peening over the ends of the opening, as seen at 27. To be retained in place, pins 11 for this embodiment are preferably made with a slightly tapered or bowed inner end, so that expansion of the sleeve 25 during insertion is facilitated.

Embodiment of FIGS. 12-14. the bars holding the pins need not provide closed openings drilled through the bars, as in the embodiments of FIGS. 1-11, but they may be formed as open, comb-like structures applied to a base. Thus, the bars 28 are formed with a projecting comb 29, separated by parallel grooves 29'. As seen in FIG. 12, these grooves may be of square cross section, or they may be circular (FIG. 14) or otherwise shaped. The depth of the grooves preferably is slightly less than the diameter of the pins 11 to be placed therein. The bars 28 are preferably made of metal, for example by die-casting, or by milling metal bars. To hold the pins in place, a long comb-like leaf spring is attached to the side of the bar, for example by riveting, adhesion, spot-welding or the like. The comb-like spring bar is shaped so that at its inner end the comb extensions 30' (FIG. 14) are bent over towards the grooves, to be spread outwardly as seen in FIG. 14 at 31 upon insertion of a pin 11. Preferably, the inner surfaces of the projections 29 are chamfered to permit the teeth 30' of the spring plate 30 to be bent over and to permit resilient deformation thereof and positive holding of the pins 11.

The bars 28 are held in position on the base ratchet wheel 34 by being placed in a ring groove 35, tapering downwardly; the head nut 33 is formed with a similar inwardly tapering surface 36, and the elements 28 are formed with matching end tapering surfaces fitting against the grooves formed by surfaces 35, 36. The radial placement of the bars is ensured by engaging the bars themselves into grooves 32 formed in the base

body structure 31. In this form of the invention, the base body structure extends towards the outside circumferential surface of the selector drum itself to locate the comb-like holding bars 28, the spring strip 30, and the pins 11 in the openings, securely in position. The bars and strips can be made narrow. The radial extent of the base body structure need be just sufficient to securely hold the bars in position. Of course, the bars may also be held in position as explained in connection with the examples of the previously discussed Figures.

The structure is applicable not only to the placement and holding of control pins 11; FIG. 15 illustrates retention of a standard Jacquard selector jack. Bar 60, which may be of light metal, plastic or the like, and basically of similar shape to bar 28 (FIG. 12) has a shallow recess 61 formed therein which matches the shape of a Jacquard selector jack 62, which is then placed into the shallow recess. The selector jack 62 is held in position by a counter element 69, which may again be of spring metal similar to spring strip 30 or preferably is a plastic strip, particularly if bar 60 is likewise of plastic, as indicated in FIG. 15. The two strips may be interlocked by means of small projections (not shown) on strip 69 fitting into holes 66 in bar 60 with a slight interference fit. The butts 63 of jack 62 are broken off as desired; the type of coding on the jacks, with respect to the bars, can be indicated by a code index on the bar 60, such as the letter "C" as seen at 66 on bar 60. A similar projecting letter can be shaped, as slight projection, in the recess 61, to fit a similar letter punched through the jack 62. Thus, when the punch mark on the jack 62 fits the raised index position on the inside, the proper jack has been fitted into the proper bar or jack carrier. Additionally, the shape of the end portions 65, 65' of the jack can be made to match the shape of the end portions 64, 64' of the recess so that the jack is positively located in an identified carrier bar in a predetermined identified position.

The bar 60, and the holding counter element 69, if required, can be held in the body in accordance with any of the previously described embodiments, that is, by an inwardly radially extending ridge fitting into a groove (FIG. 10) by slots cut into the drum body (FIGS. 12, 13) or by end holding arrangements (FIGS. 1, 5, 6) or the like.

To facilitate insertion of the bars, an arrangement as described in the cross referenced application Ser. No. 191,179, now Pat. No. 3,712,084, filed Oct. 21, 1971, may be used.

Various changes and modifications may be made within the inventive concept.

We claim:

1. Cylindrical Jacquard pattern carrier drum for circular knitting machines comprising
  - a generally cylindrical body structure having a stem (1,22), a base (4) and means providing for rotation of the body structure;
  - a plurality of individual, separable elongated holding bars (6, 26, 28, 60) secured to said stem and spaced radially from the axis thereof and extending essentially parallel to the axis at the outside of the circumference of the pattern carrier;
  - means engaging the top and bottom end portions of the holding bars (5, 9, 10) to secure said separable holding bars to the cylindrical body structure (6) in circumferential radially spaced position sur-

rounding the body structure to form at least a surface portion of the cylindrical carrier, and to rotate conjointly with the body structure, and further to locate the individual bars on the body structure with respect to a radial datum (A, B) on the body structure;

the bars being formed on opposite side surfaces with interengaging, matching recess and projection means (15, 16) to hold the bars in place against radial movement and in locked engagement with each other;

and projecting Jacquard control elements (11) projecting from said separable bars radially with respect to said stem.

2. Drum according to claim 1, wherein the number of the plurality of holding bars (6) corresponds to the number of circumferential selection positions of the drum.

3. Drum according to claim 2, wherein the bars (6) are fitted tightly against each other.

4. Drum according to claim 1, wherein the projection and recess means on the side surface of each bar comprises

at least one longitudinal groove (15) formed on one side surface and a longitudinal projection (16) fitting into said groove formed on the other side surface to hold the bars in place against radial movement but permit axial sliding of the bars with respect to each other and permit assembly or replacement of the bars.

5. Drum according to claim 1, wherein the bars (6) are formed with radially penetrating openings and said control elements are pins (11) inserted in said openings, said bars comprising elastically deformable material and the retaining means comprises a constricted region (19) in said openings (14) extending from one side thereof and a relief (20) at the outside of the bar opposite the constricted region to permit elastic deformation of said bar upon insertion of a pin (11) into the opening.

6. Drum according to claim 1, wherein the bars are formed with radially penetrating openings and said control elements are pins (11) inserted in said openings;

and the stem (22) is formed with axially extending grooves (21) located with respect to said openings to receive the inner ends of the pins (11).

7. Drum according to claim 1, wherein the bars are formed with radially penetrating openings and said control elements are pins (11) inserted in said openings;

and wherein the retaining means comprises spring sleeves (25) fitted into the bars (26) and located in the openings, the spring sleeves being normally slightly smaller than the outside of the pins and yieldingly expandable to hold the pins in the opening.

8. Drum according to claim 1, wherein the means securing the holding bars (6, 26, 28, 60) to the body structure (1, 22) comprises radially projecting means (5, 9) and tongue-and-groove means (7, 17, 8, 18) on the bars and the radially projecting means, respectively.

9. Drum according to claim 1, wherein the interengaging means comprises tongue-and-groove means.

10. Drum according to claim 8, wherein the radially projecting means are formed with tines, and the bars

9

10

are formed with depressions, said tines fitting into said depressions and said tines and depressions forming said tongue-and-groove means.

prises at least one crown wheel (5, 9) secured to said stem, and interengaging, interlocking means formed on said bars and on the crown wheel to lock the bars and the crown wheel together.

11. Drum according to claim 1, wherein the means securing the holding bars to the body structure com-

\* \* \* \* \*

10

15

20

25

30

35

40

45

50

55

60

65