



- (51) International Patent Classification:
C10L 3/10 (2006.01) *E21B 43/16* (2006.01)
- (21) International Application Number:
PCT/US2014/018091
- (22) International Filing Date:
24 February 2014 (24.02.2014)
- (25) Filing Language: English
- (26) Publication Language: English
- (30) Priority Data:
61/775,168 8 March 2013 (08.03.2013) US
- (71) Applicant (for all designated States except US): **EXXON-MOBIL UPSTREAM RESEARCH COMPANY** [US/US]; CORP-URC-SW359, P.O. Box 2189, Houston, TX 77252-2189 (US).
- (72) Inventors; and
- (71) Applicants (for US only): **DHANUKA, Sulabh, K.** [IN/US]; 2423 Haverhill Drive, Houston, TX 77008 (US). **EATON, Michael, W.** [US/US]; 1975 Grant St., Unit 801, Denver, CO 80203 (US). **HUNTINGTON, Richard, A.** [US/US]; 4506 Feagan Street, Houston, TX 77007 (US).

- (74) Agents: **SULLIVAN, Jamie, L.** et al.; Exxonmobil Upstream Research Company, CORP-URC-SW359, P.O. Box 2189, Houston, TX 77252-2189 (US).
- (81) Designated States (unless otherwise indicated, for every kind of national protection available): AE, AG, AL, AM, AO, AT, AU, AZ, BA, BB, BG, BH, BN, BR, BW, BY, BZ, CA, CH, CL, CN, CO, CR, CU, CZ, DE, DK, DM, DO, DZ, EC, EE, EG, ES, FI, GB, GD, GE, GH, GM, GT, HN, HR, HU, ID, IL, IN, IR, IS, JP, KE, KG, KN, KP, KR, KZ, LA, LC, LK, LR, LS, LT, LU, LY, MA, MD, ME, MG, MK, MN, MW, MX, MY, MZ, NA, NG, NI, NO, NZ, OM, PA, PE, PG, PH, PL, PT, QA, RO, RS, RU, RW, SA, SC, SD, SE, SG, SK, SL, SM, ST, SV, SY, TH, TJ, TM, TN, TR, TT, TZ, UA, UG, US, UZ, VC, VN, ZA, ZM, ZW.
- (84) Designated States (unless otherwise indicated, for every kind of regional protection available): ARIPO (BW, GH, GM, KE, LR, LS, MW, MZ, NA, RW, SD, SL, SZ, TZ, UG, ZM, ZW), Eurasian (AM, AZ, BY, KG, KZ, RU, TJ, TM), European (AL, AT, BE, BG, CH, CY, CZ, DE, DK, EE, ES, FI, FR, GB, GR, HR, HU, IE, IS, IT, LT, LU, LV, MC, MK, MT, NL, NO, PL, PT, RO, RS, SE, SI, SK, SM, TR), OAPI (BF, BJ, CF, CG, CI, CM, GA, GN, GQ, GW, KM, ML, MR, NE, SN, TD, TG).

[Continued on next page]

(54) Title: POWER GENERATION AND METHANE RECOVERY FROM METHANE HYDRATES

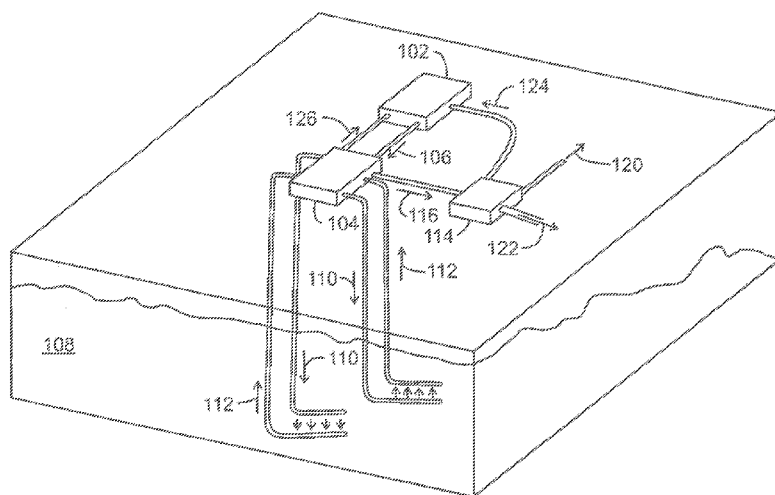

100
FIG. 1

(57) Abstract: The present techniques are directed to a system and method for generating power and recovering methane from methane hydrates. The system includes a low emissions power plant configured to generate power, wherein an exhaust gas from the low emissions power plant provides a gas mixture including nitrogen and carbon dioxide. The system also includes a methane recovery system configured to recover methane from methane hydrates by injecting the nitrogen and the carbon dioxide from the gas mixture into the methane hydrates.



Declarations under Rule 4.17:

- *as to applicant's entitlement to apply for and be granted a patent (Rule 4.17(ii))*
- *as to the applicant's entitlement to claim the priority of the earlier application (Rule 4.17(iii))*

Published:

- *with international search report (Art. 21(3))*

**POWER GENERATION AND METHANE RECOVERY FROM METHANE
HYDRATES**

CROSS REFERENCE TO RELATED APPLICATIONS

- 5 [0001] This application claims the priority benefit of United States Patent Application 61/775,168 filed March 8, 2013 entitled POWER GENERATION AND METHANE RECOVERY FROM METHANE HYDRATES, the entirety of which is incorporated by reference herein.

FIELD

- 10 [0002] The present disclosure relates generally to the integration of power generation and methane recovery from methane hydrates. More particularly, the present disclosure relates to systems and methods for generating power via a power plant and using an exhaust gas from the power plant to recover methane from methane hydrates.

BACKGROUND

- 15 [0003] This section is intended to introduce various aspects of the art, which may be associated with exemplary embodiments of the present techniques. This discussion is believed to assist in providing a framework to facilitate a better understanding of particular aspects of the present techniques. Accordingly, it should be understood that this section should be read in this light, and not necessarily as admissions of prior art.
- 20 [0004] A large volume of methane is currently contained in permafrost regions in the form of methane hydrates. In many cases, it may be desirable to recover the methane from the methane hydrates. Several techniques for recovering methane from methane hydrates have been explored. According to one technique, methane is recovered from methane hydrates via thermal stimulation. This may be accomplished by injecting high-temperature
- 25 water into the hydrate layer through a pipeline. Another technique involves dissociating the methane from the methane hydrates via depressurization using a vacuum device. In addition, another technique involves dissociating the methane from the methane hydrates using inhibitors that cause the methane hydrates to become unstable.
- [0005] U.S. Patent No. 7,988,750 to Lee et al. describes a method for recovering methane
- 30 gas from methane hydrates by adding a gas mixture containing nitrogen and carbon dioxide gases to the methane hydrates. Specifically, the methane within the methane hydrates is

reacted with the gas mixture, and the gas mixture replaces the methane within the methane hydrates, thus releasing the methane. Furthermore, the gas mixture containing the nitrogen and carbon dioxide may be a flue gas obtained from a factory. However, the flue gas may include gas components other than nitrogen and carbon dioxide, such as water, sulfur, and a
5 variety of other gas components. Thus, a cleanup apparatus may be used to protect the environment by removing the extra gas components from the flue gas prior to injection of the flue gas into the methane hydrates. In some cases, removing the gas components from the flue gas results in a significant increase in operating cost, thus rendering recovery of the methane from the methane hydrates less profitable.

10 [0006] A conventional gas turbine engine often has a turbine compressor that is mechanically linked to a turbine expander through a shaft. The turbine compressor can be used to compress a flow of air ingested by the turbine compressor. The compressed air is then passed to a combustor. In the combustor, fuel is injected and ignited to create a continuous flame. The high pressure exhaust gases from the flame are flowed into the turbine
15 expander, which generates mechanical energy from the exhaust gas as it expands. The mechanical energy, transferred through the shaft to the turbine compressor, is used to power the compression of the air. Additional mechanical energy is produced, over the amount used to compress the ingested air, and harvested for other purposes, for example, to generate electricity. The flame temperature can exceed the metallurgical limits of the combustor can,
20 so an excess amount of air is often used to provide cooling. However, this arrangement may create a higher amount of pollutants, such as nitrogen oxides (NO_xs).

[0007] Capturing carbon dioxide from the exhaust gas for other uses may be problematic for a number of reasons. For example, there is a low concentration of carbon dioxide in the exhaust gas of a conventional gas turbine, and a very large volume of gas has to be treated.
25 The exhaust gas may also be at a relatively low pressure, *e.g.*, around 1050 kilopascals (kPa), and a relatively high temperature, *e.g.*, from around 425 degrees Celsius (°C) to around 700 °C. Further, the exhaust gas may contain a large amount of oxygen that may interfere with CO₂ extraction or use. Finally, the exhaust gas may be saturated with water from cooling, which can increase a reboiler duty in the CO₂ extraction system.

30 [0008] The combustion of fuel within a combustor, *e.g.*, integrated with a gas turbine, can be controlled by monitoring the temperature of the exhaust gas leaving the expander, because temperatures are generally too high in the combustor for existing instrumentation. At full load, typical gas turbines adjust the amount of fuel introduced to a number of combustors in

order to reach a desired combustion gas or exhaust gas temperature.

[0009] However, controlling the amount of oxidant introduced to the combustor can also be desirable when an objective is to capture carbon dioxide (CO₂) from the exhaust gas. Current carbon dioxide capture technology is expensive for several reasons. For example, the
5 low pressure and low concentration of carbon dioxide in an exhaust gas. The carbon dioxide concentration, however, can be significantly increased from about 4 % to greater than 10 % by operating the combustion process under substantially stoichiometric conditions. Further, a portion of the exhaust gas may be recycled to the combustor as a diluent for cooling the products of combustion instead of air.

10 [0010] The enhanced exhaust gases may be captured for use by other systems, for example, directly from the exhaust of the gas turbine. However, if a gas turbine is being supplied an oxidant from a separate source, it may be more effective to compress the exhaust gas in the turbine compressor of the gas turbine, and recycle the compressed gas to the combustors as a coolant, then capture a high pressure bleed flow during the control of the
15 recycle flow. Numerous studies have examined the concept of recycling a portion of the exhaust gases to the combustor.

[0011] For example, U.S. Patent No. 4,271,664 to Earnest discloses a turbine engine with exhaust gas recirculation. The engine has a main power turbine operating on an open-loop Brayton cycle. The air supply to the main power turbine is furnished by a compressor
20 independently driven by the turbine of a closed-loop Rankine cycle which derives heat energy from the exhaust gas of the Brayton turbine. A portion of the exhaust gas is recirculated into the compressor inlet during part-load operation. However, no additional uses are disclosed for the recycled exhaust gas.

SUMMARY

25 [0012] An exemplary embodiment of the present techniques provides a system for generating power and recovering methane from methane hydrates. The system includes a low emissions power plant configured to generate power, wherein an exhaust gas from the low emissions power plant provides a gas mixture including nitrogen and carbon dioxide. The system also includes a methane recovery system configured to recover methane from
30 methane hydrates by injecting the nitrogen and the carbon dioxide from the gas mixture into the methane hydrates.

[0013] Another exemplary embodiment provides a method for generating power and recovering methane from methane hydrates. The method includes producing power via a low

emissions power plant, wherein an exhaust gas from the low emissions power plant provides a gas mixture including nitrogen and carbon dioxide. The method also includes recovering methane from methane hydrates by injecting the nitrogen and the carbon dioxide from the gas mixture into the methane hydrates.

5 [0014] Another exemplary embodiment provides a system for recovering methane from methane hydrates using a gas mixture from a combined cycle power plant. The system includes an expander turbine configured to provide mechanical energy by extracting energy from a gas mixture exiting a combustor, wherein the gas mixture including nitrogen and carbon dioxide. The system also includes a heat recovery steam generator (HRSG)
10 configured to generate steam by heating a boiler with the gas mixture from the expander turbine, a steam turbine configured to provide mechanical energy by extracting energy from the steam generated by the HRSG, and a generator configured to generate electricity from the mechanical energy provided by the expander turbine and the steam turbine. The system further includes a separation system configured to separate the carbon dioxide from the
15 methane within the gas mixture and a methane recovery system configured to recover methane from methane hydrates by injecting the nitrogen and the carbon dioxide from the gas mixture into the methane hydrates. At least a portion of the methane recovered from the methane hydrates is flowed into the combustor as fuel.

BRIEF DESCRIPTION OF THE DRAWINGS

20 [0015] The advantages of the present techniques are better understood by referring to the following detailed description and the attached drawings, in which:

[0016] **Fig. 1** is a schematic of a development for generating power and recovering methane from methane hydrates;

[0017] **Fig. 2** is a process flow diagram of a combined cycle power plant that can be used
25 to produce electricity and generate a diluent gas mixture including nitrogen (N₂) and carbon dioxide (CO₂);

[0018] **Fig. 3** is a process flow diagram of a system for integrating low emissions power generation with methane recovery from methane hydrates;

[0019] **Fig. 4** is a graph showing N₂/CO₂ hydrate formation curves as a function of
30 temperature, pressure, and nitrogen mole fraction;

[0020] **Fig. 5** is a process flow diagram of another system for integrating low emissions power generation with methane recovery from methane hydrates;

[0021] Fig. 6 is a perspective view of a pipeline configuration for recovering methane from a methane hydrate formation;

[0022] Fig. 7 is a perspective view of another pipeline configuration for recovering methane from a methane hydrate formation; and

5 [0023] Fig. 8 is a process flow diagram of a method for power generation and methane recovery from methane hydrates.

DETAILED DESCRIPTION

[0024] In the following detailed description section, specific embodiments of the present techniques are described. However, to the extent that the following description is specific to
10 a particular embodiment or a particular use of the present techniques, this is intended to be for exemplary purposes only and simply provides a description of the exemplary embodiments. Accordingly, the techniques are not limited to the specific embodiments described herein, but rather, include all alternatives, modifications, and equivalents falling within the true spirit and scope of the appended claims.

15 [0025] At the outset, for ease of reference, certain terms used in this application and their meanings as used in this context are set forth. To the extent a term used herein is not defined herein, it should be given the broadest definition persons in the pertinent art have given that term as reflected in at least one printed publication or issued patent. Further, the present techniques are not limited by the usage of the terms shown herein, as all equivalents,
20 synonyms, new developments, and terms or techniques that serve the same or a similar purpose are considered to be within the scope of the present claims.

[0026] A “combined cycle power plant” is generally the combination of an open Brayton Cycle and a Rankine cycle. Combined cycle power plants typically use both steam and gas turbines to generate power, although other working fluids besides water and steam may be
25 used in the Rankine cycle. The combined cycle gas/steam power plants generally have a higher energy conversion efficiency than gas or steam only plants. A combined cycle plant's efficiencies can be as high as 50 % to 60 % of a lower heating value (LHV). The higher combined cycle efficiencies result from synergistic utilization of a combination of the gas turbine with the steam turbine. Typically, combined cycle power plants utilize heat from the
30 gas turbine exhaust to boil water to generate steam. The boilers in typical combined cycle plants can be referred to as heat recovery steam generator (HRSG). The steam generated is utilized to power a steam turbine in the combined cycle plant. The gas turbine and the steam turbine can be utilized to separately power independent generators, or in the alternative, the

steam turbine can be combined with the gas turbine to jointly drive a single generator via a common drive shaft.

[0027] As used herein, a “compressor” includes any type of equipment designed to increase the pressure of a fluid or working fluid, and includes any one type or combination of similar or different types of compression equipment. A compressor may also include auxiliary equipment associated with the compressor, such as motors, and drive systems, among others. The compressor may utilize one or more compression stages, for example, in series. Illustrative compressors may include, but are not limited to, positive displacement types, such as reciprocating and rotary compressors for example, and dynamic types, such as centrifugal and axial flow compressors, for example. For example, a compressor may be a first stage in a gas turbine engine, as discussed in further detail herein.

[0028] As used herein, “cooling” broadly refers to lowering and/or dropping a temperature and/or internal energy of a substance, such as by any suitable amount. Cooling may include a temperature drop of at least about 1 degree Celsius ($^{\circ}\text{C}$), at least about 5°C , at least about 10°C , at least about 15°C , at least about 25°C , at least about 50°C , at least about 100°C , and/or the like. The cooling may use any suitable heat sink, such as steam generation, hot water heating, cooling water, air, refrigerant, other process streams (integration), and combinations thereof. One or more sources of cooling may be combined and/or cascaded to reach a desired outlet temperature. The cooling step may use a cooling unit with any suitable device and/or equipment. According to one embodiment, cooling may include indirect heat exchange, such as with one or more heat exchangers. Heat exchangers may include any suitable design, such as shell and tube, plate and frame, counter current, concurrent, extended surface, and/or the like. In the alternative, the cooling may use evaporative (heat of vaporization) cooling and/or direct heat exchange, such as a liquid sprayed directly into a process stream.

[0029] “Cryogenic temperature” refers to a temperature that is about -50°C or below.

[0030] A “diluent” is a gas used to lower the concentration of oxidant fed to a gas turbine to combust a fuel. The diluent may be an excess of nitrogen, carbon dioxide, combustion exhaust, or any number of other gases. In embodiments, the diluent may also provide cooling to a combustor.

[0031] An “equivalence ratio” refers to the mass ratio of fuel to oxygen entering a combustor divided by the mass ratio of fuel to oxygen when the ratio is stoichiometric. A perfect combustion of fuel and oxygen to form carbon dioxide and water would have an

equivalence ratio of 1. A too lean mixture, *e.g.*, having more oxygen than fuel, would provide an equivalence ratio less than 1, while a too rich mixture, *e.g.*, having more fuel than oxygen, would provide an equivalence ratio greater than 1.

[0032] “Exemplary” is used exclusively herein to mean “serving as an example, instance,
5 or illustration.” Any embodiment described herein as “exemplary” is not to be construed as preferred or advantageous over other embodiments.

[0033] A “formation” is any finite subsurface region. The formation may contain one or more hydrocarbon-containing layers, one or more non-hydrocarbon containing layers, an overburden, and/or an underburden of any subsurface geologic formation. An “overburden”
10 and/or an “underburden” is geological material above or below the formation of interest.

[0034] A “fuel” includes any number of hydrocarbons that may be combusted with an oxidant to power a gas turbine. Such hydrocarbons may include natural gas, treated natural gas, kerosene, gasoline, or any number of other natural or synthetic hydrocarbons. In one embodiment, natural gas from an oil field is purified and used to power the turbine. In
15 another embodiment, a reformed gas, for example, created by processing a hydrocarbon in a steam reforming process may be used to power the turbine.

[0035] The term “gas” is used interchangeably with “vapor,” and is defined as a substance or mixture of substances in the gaseous state as distinguished from the liquid or solid state. Likewise, the term “liquid” means a substance or mixture of substances in the
20 liquid state as distinguished from the gas or solid state.

[0036] A “gas turbine engine” operates on the Brayton cycle. If the exhaust gas is vented to the atmosphere, this is termed an open Brayton cycle, while recycling of the exhaust gas gives a closed Brayton cycle. As used herein, a “gas turbine” typically includes a compressor section, a number of combustors, and an expander turbine section. The compressor may be
25 used to compress an oxidant, which is mixed with a fuel and channeled to the combustors. The mixture of fuel and oxidant is then ignited to generate hot combustion gases. The combustion gases are channeled to the expander turbine section which extracts energy from the combustion gases for powering the compressor, as well as producing useful work to power a load. In embodiments discussed herein, the oxidant may be provided to the
30 combustors by an external compressor, which may or may not be mechanically linked to the shaft of the gas turbine engine. Further, in embodiments, the compressor section may be used to compress a diluent, such as recycled exhaust gases, which may be fed to the combustors as a coolant.

[0037] A “heat exchanger” broadly means any device capable of transferring heat from one media to another media, including particularly any structure, *e.g.*, device commonly referred to as a heat exchanger. Heat exchangers include “direct heat exchangers” and “indirect heat exchangers.” Thus, a heat exchanger may be a plate-and-frame, shell-and-tube, spiral, hairpin, core, core-and-kettle, double-pipe or any other type of known heat exchanger. “Heat exchanger” may also refer to any column, tower, unit or other arrangement adapted to allow the passage of one or more streams therethrough, and to affect direct or indirect heat exchange between one or more lines of refrigerant, and one or more feed streams.

[0038] A “heat recovery steam generator” or “HRSG” is a heat exchanger or boiler that recovers heat from a hot gas stream. It produces steam that can be used in a process or used to drive a steam turbine. A common application for an HRSG is in a combined-cycle power plant, where hot exhaust from a gas turbine is fed to the HRSG to generate steam which in turn drives a steam turbine. This combination produces electricity more efficiently than either the gas turbine or steam turbine alone.

[0039] As used herein, a “hydrate” is a composite made of a host compound that forms a basic framework and a guest compound that is held in the host framework by inter-molecular interaction, such as hydrogen bonding, Van der Waals forces, and the like. Hydrates may also be called host-guest complexes, inclusion compounds, and adducts. As used herein, “clathrate,” “clathrate hydrate,” and “hydrate” are interchangeable terms used to indicate a hydrate having a basic framework made from water as the host compound. A hydrate is a crystalline solid which looks like ice and forms when water molecules form a cage-like structure around a “hydrate-forming constituent.”

[0040] A “hydrate-forming constituent” refers to a compound or molecule in petroleum fluids, including natural gas, that forms hydrate at elevated pressures and/or reduced temperatures. Illustrative hydrate-forming constituents include, but are not limited to, hydrocarbons such as methane, ethane, propane, butane, neopentane, ethylene, propylene, isobutylene, cyclopropane, cyclobutane, cyclopentane, cyclohexane, and benzene, among others. Hydrate-forming constituents can also include non-hydrocarbons, such as oxygen, nitrogen, hydrogen sulfide, carbon dioxide, sulfur dioxide, and chlorine, among others. According to embodiments described herein, a hydrate that is formed from methane is referred to as a “methane hydrate.” Methane hydrates may occur frequently in permafrost regions, such as in the Arctic, for example.

[0041] A “hydrocarbon” is an organic compound that primarily includes the elements

hydrogen and carbon, although nitrogen, sulfur, oxygen, metals, or any number of other elements may be present in small amounts. As used herein, hydrocarbons generally refer to components found in raw natural gas, such as CH₄, C₂H₂, C₂H₄, C₂H₆, C₃ isomers, C₄ isomers, benzene, and the like.

5 [0042] “Natural gas” refers to a multi-component gas obtained from a crude oil well or from a subterranean gas-bearing formation. The composition and pressure of natural gas can vary significantly. A typical natural gas stream contains methane (CH₄) as a major component, *i.e.*, greater than 50 mol % of the natural gas stream is methane. The natural gas stream can also contain ethane (C₂H₆), higher molecular weight hydrocarbons (*e.g.*, C₃-C₂₀
10 hydrocarbons), one or more acid gases (*e.g.*, carbon dioxide or hydrogen sulfide), or any combinations thereof. The natural gas can also contain minor amounts of contaminants such as water, nitrogen, iron sulfide, wax, crude oil, or any combinations thereof. The natural gas stream may be substantially purified prior to use in embodiments, so as to remove compounds that may act as poisons.

15 [0043] An “oxidant” is a gas mixture that can be flowed into the combustors of a gas turbine engine to combust a fuel. As used herein, the oxidant may be oxygen mixed with any number of other gases as diluents, including carbon dioxide (CO₂), nitrogen (N₂), air, combustion exhaust, and the like. Other gases that function as oxidizers may be present in the oxidant mixture in addition to oxygen, including ozone, hydrogen peroxide, NO_xs, and
20 the like.

[0044] “Pressure” is the force exerted per unit area by the gas on the walls of the volume. Pressure can be shown as pounds per square inch (psi). “Atmospheric pressure” refers to the local pressure of the air. “Absolute pressure” (psia) refers to the sum of the atmospheric pressure (14.7 psia at standard conditions) plus the gage pressure (psig). “Gauge pressure”
25 (psig) refers to the pressure measured by a gauge, which indicates only the pressure exceeding the local atmospheric pressure (*i.e.*, a gauge pressure of 0 psig corresponds to an absolute pressure of 14.7 psia). The term “vapor pressure” has the usual thermodynamic meaning. For a pure component in an enclosed system at a given pressure, the component vapor pressure is essentially equal to the total pressure in the system.

30 [0045] The term “permafrost” refers to perennially frozen ground, *i.e.*, a naturally occurring material that is at a temperature colder than 0 °C continuously for an extended period of time. Such a layer of frozen ground is designated exclusively on the basis of temperature. Part or all of its moisture may be unfrozen, depending on the chemical

composition of the water or the depression of the freezing point by capillary forces. Most permafrost, however, is consolidated by ice. In addition to water, permafrost can store any number of other substances. For example, permafrost can store methane and/or carbon dioxide in the form of hydrates. Permafrost forms and exists in a climate where the mean
5 annual air temperature is 0 °C or colder. Such a climate is generally characterized by long, cold winters and short, relatively dry, cool summers. Permafrost, therefore, is widespread in the Arctic, sub-Arctic, and Antarctica.

[0046] “Substantial” when used in reference to a quantity or amount of a material, or a specific characteristic thereof, refers to an amount that is sufficient to provide an effect that
10 the material or characteristic was intended to provide. The exact degree of deviation allowable may in some cases depend on the specific context.

Overview

[0047] Embodiments described herein provide a system and method for the integration of low emissions power generation with the recovery of methane from methane hydrates.
15 According to such embodiments, a gas mixture including N₂ and CO₂ is generated from a low emissions power plant during the generation of power. The gas mixture is used to recover methane trapped in methane hydrates in permafrost regions, for example. In some embodiments, the recovered methane is then used as fuel for the low emissions power plant, thus providing an integrated power generation and methane recovery system.

20 Systems for Power Generation and Methane Recovery from Methane Hydrates

[0048] **Fig. 1** is a schematic of a development **100** for generating power and recovering methane from methane hydrates. In various embodiments, the development **100** is located in a permafrost region, such as the Arctic or sub-Arctic, for example. The development **100** includes a low emissions power plant **102** that is integrated with a methane recovery system
25 **104**.

[0049] The low emissions power plant **102** may be a semi-closed Brayton cycle power plant, or a combined cycle power plant that includes both a semi-closed Brayton cycle and a Rankine cycle. If the low emissions power plant **102** is a combined cycle power plant, the exhaust stream from the expander turbine of the semi-closed Brayton cycle can be used to
30 boil water or other heat transfer fluids in a heat recovery steam generator (HRSG) that can be used to power the Rankine cycle power plant. In the Rankine cycle power plant, the steam or other vapor can be used to drive a turbine and generate more electricity.

[0050] According to embodiments described herein, an exhaust gas from the low emissions power plant **102** provides a gas mixture including mostly N₂ and CO₂. The gas mixture from the low emissions power plant **102** is provided to the methane recovery system **104**, as indicated by arrow **106**.

5 [0051] The methane recovery system **104** includes an injection system for injecting the gas mixture into a methane hydrate formation **108**, as indicated by arrows **110**. In various embodiments, injecting the gas mixture into the methane hydrate formation **108** results in the release of the methane from the methane hydrates. Specifically, the carbon dioxide within the gas mixture replaces the methane within the methane hydrates. In addition, the nitrogen
10 within the gas mixture aids in the release of the methane from the methane hydrates by increasing the temperature of the methane hydrates. The released methane is then flowed back to the methane recovery system **104**, as indicated by arrows **112**.

[0052] In some embodiments, the methane recovery system **104** also includes a separation system for separating the gas mixture into a carbon dioxide stream and a nitrogen
15 stream. The carbon dioxide stream and the nitrogen stream may then be separately injected into the methane hydrate formation **108**.

[0053] The methane that is recovered via the methane recovery system **104** may include some amount of impurities, such as soil or water from the methane hydrate formation **108** or surrounding permafrost. Therefore, the methane may be flowed to a separation facility **114**,
20 as indicated by arrow **116**. The separation facility **114** may remove the impurities from the methane and send the impurities to another destination, such as a tailings pond, for example, as indicated by arrow **118**. The purified methane may then be offloaded as the final methane product, as indicated by arrow **120**.

[0054] In various embodiments, a portion of the purified methane may be sent from the
25 separation facility **114** to the low emissions power plant **102**, as indicated by arrow **122**. The methane may then be used as fuel for the gas turbine engine of the low emissions power plant **102**. Furthermore, in some embodiments, the methane recovered via the methane recovery system **104** is substantially pure and may be used as fuel for the gas turbine engine of the low emissions power plant **102** without being purified within the separation facility **114**. In such
30 embodiments, the recovered methane may be flowed directly from the methane recovery system **104** to the low emissions power plant **102**, as indicated by arrow **124**.

[0055] The block diagram of **Fig. 1** is not intended to indicate that the development **100** is to include all of the components shown in **Fig. 1**. Moreover, the development **100** may

include any number of additional components not shown in **Fig. 1**, depending on the details of the specific implementation.

[0056] **Fig. 2** is a process flow diagram of a combined cycle power plant **200** that can be used to produce electricity **202** and generate a diluent gas mixture including N_2 and CO_2 . In various embodiments, the combined cycle power plant **200** is implemented within the development **100** as the low emissions power plant **102**. Further, in various embodiments, the combined cycle power plant **200** includes a semi-closed Brayton cycle including, for example, an expander turbine **206**, and a Rankine cycle including, for example, a HRSG **208**.

[0057] Within the combined cycle power plant **200**, oxidant **210** and fuel gas **212** are fed to a combustor **214** to be burned. A compressed diluent stream **216** is also fed to the combustor **214** to lower the total amount of fuel gas **212** and oxidant **210**, which allows the combustion process to be run at near stoichiometric conditions without overheating the combustor **214** or the expander turbine **206**. As a result, the amount of O_2 and CO generated in the combustion process is decreased, and hot exhaust gas **218** exiting the combustor includes mostly CO_2 , H_2O , and N_2 , in addition to some trace gases, such as CO and NO_x .

[0058] The oxidant **210** and fuel gas **212** pressures may be increased, for example, using compressors, to boost the pressure to match the injection pressure of the compressed diluent stream **216** at the combustor **214**. The hot exhaust gas **218** from the combustor **214** is flowed to the expander turbine **206**, which uses the energy of the hot exhaust gas **218** to spin a shaft **220**. The shaft **220** provides mechanical energy to the compressor turbine **224**, completing the Brayton cycle. The shaft **220** may also provide mechanical energy to an electric generator **222** to generate electricity **202**. The electric generator **222** may be directly coupled to the shaft **220** from the expander turbine **206**, or may be coupled to the shaft **220** by a gear box, clutch, or other device.

[0059] From the expander turbine **206**, the hot exhaust gas **218** is flowed to the HRSG **208**. The HRSG **208** may boil a water stream **224** with the energy from the hot exhaust gas **218** to generate steam **226**. The steam **226** that is generated can be used to drive a steam turbine **228** and spin a shaft **230**. After exiting the steam turbine **228**, the resulting low pressure steam **232** can be cooled and condensed, to be used as the water stream **224** to feed the HRSG **208**.

[0060] The shaft **230** from the steam turbine **228** can provide mechanical energy to an electric generator **234** to generate electricity **202**, or may be used power other devices, such as compressors. The electric generator **234** may be directly coupled to the shaft **230** from the

steam turbine **228**, or may be coupled to the shaft **230** by a gear box, clutch, or other device. Further, in the embodiment shown in **Fig. 2**, the expander turbine **206** and the steam turbine **228** are coupled to separate electric generators **222** and **234**. However, it is to be understood that the expander turbine **206** and the steam turbine **228** may also be coupled, directly or
5 indirectly, to one common electric generator.

[0061] The hot gas stream **236** exiting the HRSG **208** is flowed to a cooler **238**. The cooler **238** chills the hot gas stream **236**, causing the water vapor formed in the combustion process to condense out, allowing its removal as a separate water stream **240**. After removal of the water stream **240**, the chilled gas mixture **242** is provided to a compressor **244** for
10 recompression, prior to feeding the compressed diluent stream **216** to the combustor **214** to aid in cooling the combustor **214**. The recycling of the hot gas stream **236** as the diluent stream **216** partially closes the Brayton cycle in the combined cycle power plant **200**, resulting in a semi-closed Brayton cycle.

[0062] As the fuel gas **212** and the oxidant **210** are continuously being fed to the
15 combined cycle power plant **200** to maintain the combustion, a portion **246** of the diluent stream **216** is continuously removed. The diluent stream **216** may include mostly N₂ and CO₂. According to embodiments described herein, the diluent stream **216** exiting the combined cycle power plant **200** is used to recover methane from methane hydrates, as discussed further herein.

[0063] The process flow diagram of **Fig. 2** is not intended to indicate that the combined
20 cycle power plant **200** is to include all of the components shown in **Fig. 2**. Moreover, the combined cycle power plant **200** may include any number of additional components not shown in **Fig. 2**, depending on the details of the specific implementation.

[0064] **Fig. 3** is a process flow diagram of a system **300** for integrating low emissions
25 power generation with methane recovery from methane hydrates. In various embodiments, the system **300** is implemented within the development **100** as the low emissions power plant **102** and the methane recovery system **104**. The system **300** provides for low emissions power generation using a combined cycle power plant including a semi-closed Brayton cycle that utilizes a gas turbine engine **302** and a Rankine cycle that utilizes an HRSG **304**. In
30 addition, the system **300** provides for methane recovery from methane hydrates by using exhaust gas from the combined cycle power plant to release the methane from the methane hydrates.

[0065] As shown in **Fig. 3**, air **306** and fuel gas **308** are fed to a combustor **310** to be

burned within the semi-closed Brayton cycle. While air **306** is used as the oxidant in the embodiment shown in **Fig. 3**, it is to be understood that any other suitable type of oxidant may also be used in conjunction with the system **300**.

5 [0066] A compressed diluent stream **312** is also fed to the combustor **310** to lower the total amount of air **306** and fuel gas **308** that is utilized for the combustion process. This may allow the combustion process to be run at near stoichiometric conditions without overheating. As a result, the amount of O₂ and CO generated in the combustion process is decreased, and hot exhaust gas **314** exiting the combustor includes mostly CO₂, H₂O, and N₂, in addition to some trace gases.

10 [0067] The air **306** and fuel gas **308** pressures may be increased, for example, using compressors, to boost the pressure to match the injection pressure of the compressed diluent stream **312** at the combustor **310**. For example, according to the embodiment shown in **Fig. 3**, the air **306** is compressed within an air compressor **316**. In addition, the air compressor **316** may include one or more stages of compression, and may include one or more
15 intercoolers to reduce the temperature of the air between stages. Furthermore, when more than one stage of compression is included, the individual stages may or may not be configured in a common casing or driven by a common shaft or other driving means. The compressed air **306** is then fed into the combustor **310** to be burned.

[0068] The hot exhaust gas **314** from the combustor **310** is flowed to an expander turbine
20 **322** of the gas turbine engine **302**, which uses the energy of the hot exhaust gas **314** to spin a shaft **324**. The shaft **324** provides mechanical energy to an electric generator **326** to generate electricity **328**. The electric generator **326** may be directly coupled to the shaft **324** from the expander turbine **322**, or may be coupled to the shaft **324** by a gear box, clutch, or other device.

25 [0069] From the expander turbine **322**, the hot exhaust gas **314** is flowed to the HRSG **304** within the Rankine cycle of the combined cycle power plant. The HRSG **304** boils a water stream **330** to generate steam **332** with the energy from the hot exhaust gas **314**. In various embodiments, the generated steam **332** is used to drive the steam turbine, which uses the energy of the steam **332** to spin a shaft. The shaft may provide mechanical energy to an
30 electric generator to generate additional electricity.

[0070] The hot gas stream **334** exiting the HRSG **304** is flowed to an exhaust gas recirculation (EGR) blower **336**. The EGR blower **336** compresses the hot gas stream **334** and feeds the resulting compressed gas stream **338** into an EGR cooler **340**. The EGR cooler

340 chills the compressed gas stream **338**, producing a diluent stream **342**. Cooling the hot gas stream **334** may also condense out water, drying the diluent stream **342**.

[0071] The diluent stream **342** is then fed into a compressor **344**. The compressor **344** compresses the diluent stream **342**, producing the compressed diluent stream **312**. In the
5 embodiment shown in **Fig. 3**, the compressor **344** is coupled to the shaft **324**, and the mechanical energy provided by the spinning of the shaft **324** is used to drive the compressor **344**.

[0072] From the compressor **344**, the compressed diluent stream **312** is fed to the combustor **310** to aid in cooling the combustor **310**. The recycling of the hot gas stream **334**
10 as the compressed diluent stream **312** partially closes the Brayton cycle in the combined cycle power plant, resulting in the semi-closed Brayton cycle.

[0073] As the air **306** and the fuel gas **308** are continuously being fed to the combustor **310** to maintain the combustion process, at least a portion of the compressed diluent stream **312** is continuously removed. For example, a portion of the diluent stream **312** may be
15 removed as a gas mixture **346** including mostly N_2 and CO_2 .

[0074] According to embodiments described herein, the gas mixture **346** may be extracted from the combustor **310** after it has been burned and used to drive the expander turbine **322**. For example, the gas mixture **346** may be extracted from the expander turbine **322** at about 2206 kilopascals (kPa) and 427 °C. The gas mixture **346** is then cooled using a
20 cooler **348** and, optionally, used to generate steam **332** within the HRSG **304**.

[0075] After the gas mixture **346** has been cooled within the cooler **348**, the gas mixture **346** is flowed into a methane recovery system **350**. The methane recovery system **350** includes an injection system for injecting the gas mixture **346** into a methane hydrate formation. As the gas mixture **346** is injected into the methane hydrate formation, the gas
25 mixture **346** allows the methane **352** to be released from the methane hydrates and recovered via the methane recovery system **350**.

[0076] Specifically, in some embodiments, the gas mixture **346** is injected into the methane hydrate formation at a pressure that is lower than the hydrate formation pressure of the gas mixture **346**. In such embodiments, because the gas mixture **346** has a higher hydrate
30 formation pressure than methane, the gas mixture **346** increases the temperature of the methane hydrates, allowing the methane **352** to escape from the methane hydrates. In other embodiments, the gas mixture **346** is injected into the methane hydrate formation at a pressure that is higher than the hydrate formation pressure of the gas mixture **346**. In such

embodiments, because carbon dioxide has a lower hydrate formation pressure than methane, the carbon dioxide within the gas mixture **346** preferentially replaces the methane **352** within the methane hydrates, causing the methane **352** to dissociate from the methane hydrate formation.

5 [0077] The released methane **352** is then pumped to the surface via the methane recovery system **350**. In various embodiments, the methane **352** is exported from the system **300** as the final methane product. Further, in some embodiments, at least a portion of the methane **352** is used as the fuel gas **308** for the gas turbine engine **302**.

[0078] The process flow diagram of **Fig. 3** is not intended to indicate that the system **300**
10 is to include all of the components shown in **Fig. 3**. Moreover, the system **300** may include any number of additional components not shown in **Fig. 3**, depending on the details of the specific implementation.

[0079] In various embodiments, the gas mixture **346** exiting the combined cycle power plant of the system **300** **Fig. 3** includes about 89 % nitrogen and 11 % carbon dioxide. In
15 some cases, it may be desirable to adjust the ratio of nitrogen to carbon dioxide within the gas mixture **346** prior to injecting the gas mixture into the methane hydrate formation, as discussed with respect to **Fig. 4**.

[0080] **Fig. 4** is a graph **400** showing N₂/CO₂ hydrate formation curves as a function of temperature, pressure, and nitrogen mole fraction. An x-axis **402** of the graph **400** represents
20 temperature in degrees Celsius (°C), where the temperature values range from -20 °C to 15 °C. A y-axis **404** of the graph **400** represents pressure in pounds per square inch absolute (psia), where the pressure values range from 0 psi (0 kPa) to 5,000 psi (34,474 kPa).

[0081] Each hydrate formation curve shown in **Fig. 4** represents the hydrate formation characteristics of the gas mixture **346** at a specific nitrogen mole fraction. The nitrogen mole
25 fraction is the moles of nitrogen within the gas mixture **346** divided by the sum of the moles of nitrogen and carbon dioxide within the gas mixture **346**, *i.e.*, the total moles of gas. Hydrate formation curve **406** represents a nitrogen mole fraction of 0.9. Hydrate formation curve **408** represents a nitrogen mole fraction of 0.8. Hydrate formation curve **410** represents a nitrogen mole fraction of 0.7. Hydrate formation curve **412** represents a nitrogen mole
30 fraction of 0.6. Hydrate formation curve **414** represents a nitrogen mole fraction of 0.5. Hydrate formation curve **416** represents a nitrogen mole fraction of 0.4. Hydrate formation curve **418** represents a nitrogen mole fraction of 0.3. Hydrate formation curve **420** represents a nitrogen mole fraction of 0.2. Hydrate formation curve **422** represents a nitrogen mole

fraction of 0.1, and hydrate formation curve **424** represents a nitrogen mole fraction of 0. By comparison, hydrate formation curve **426** represents pure methane.

[0082] As shown in **Fig. 4**, adjusting the nitrogen mole fraction of the gas mixture **346** allows for an adjustment of the hydrate formation characteristics of the gas mixture **346** in comparison to the hydrate formation characteristics of methane. The hydrate formation pressure of nitrogen is higher than the hydrate formation pressure of methane, while the hydrate formation pressure of carbon dioxide is lower than the hydrate formation pressure of methane. Moreover, it may be desirable for the hydrate formation pressure of the gas mixture **346** to be either above or below the hydrate formation pressure of methane, depending on the details of the specific implementation. Therefore, the nitrogen mole fraction of the gas mixture **346** may be increased or decreased based on the desired hydrate formation pressure of the gas mixture **346**.

[0083] **Fig. 5** is a process flow diagram of another system **500** for integrating low emissions power generation with methane recovery from methane hydrates. Like numbered items are as described with respect to the system **300** of **Fig. 3**. The system **500** of **Fig. 5** is similar to the system **300** of **Fig. 3**. However, according to the system **500** of **Fig. 5**, the carbon dioxide and nitrogen within the gas mixture **346** are injected into the methane hydrate formation separately.

[0084] According to the system **500** of **Fig. 5**, after the gas mixture **346** has been cooled within the cooler **348**, the gas mixture **346** is flowed into a separation system **502**. The separation system **502** separates the carbon dioxide **504** from the nitrogen **506** within the gas mixture **346**. In some embodiments, the separation system **502** accomplishes this via a CO₂ separation process, such as an amine separation process or a potassium carbonate separation process, for example.

[0085] The carbon dioxide **504** and the nitrogen **506** may then be flowed into the methane recovery system **350** as separate streams. The methane recovery system **350** may include an injection system for separately injecting the carbon dioxide **504** and the nitrogen **506** into the methane hydrate formation, or may blend the two streams **504** and **506** to a target concentration. As the carbon dioxide **504** and the nitrogen **506** are injected into the methane hydrate formation, the carbon dioxide **504** and the nitrogen **506** allow the methane **352** to be released from the methane hydrates and recovered via the methane recovery system **350**. Specifically, because nitrogen has a higher hydrate formation pressure than methane, the nitrogen **506** increases the temperature of the methane hydrates, allowing the methane **352** to

escape from the methane hydrates more easily. In addition, because carbon dioxide has a lower hydrate formation pressure than methane, the carbon dioxide **504** preferentially replaces the methane **352** within the methane hydrates, causing the methane **352** to dissociate from the methane hydrates.

5 [0086] The process flow diagram of **Fig. 5** is not intended to indicate that the system **500** is to include all of the components shown in **Fig. 5**. Moreover, the system **500** may include any number of additional components not shown in **Fig. 5**, depending on the details of the specific implementation.

[0087] **Fig. 6** is a perspective view of a pipeline configuration **600** for recovering
10 methane from a methane hydrate formation. The pipeline configuration **600** includes an injection pipeline **602** for injecting carbon dioxide and nitrogen into a methane hydrate formation, as indicated by arrow **604**. The pipeline configuration **600** also includes a production pipeline **606** for recovering methane from the methane hydrates, as indicated by arrow **608**. According to the embodiment shown in **Fig. 6**, the injection pipeline **602** and the
15 production pipeline **606** run both North to South and East to West.

[0088] In some embodiments, injecting the carbon dioxide and the nitrogen into the methane hydrate formation via the injection pipeline **602** causes the methane within the methane hydrate formation to be released. The released methane then moves in the direction of the production pipeline **606**, as indicated by arrow **610**, and is recovered via the production
20 pipeline **606**.

[0089] **Fig. 7** is a perspective view of another pipeline configuration **700** for recovering methane from a methane hydrate formation. The pipeline configuration **700** includes an injection pipeline **702** for injecting carbon dioxide and nitrogen into a methane hydrate formation, as indicated by arrow **704**. The pipeline configuration **700** also includes a
25 production pipeline **706** for recovering methane from the methane hydrates, as indicated by arrow **708**. According to the embodiment shown in **Fig. 7**, the injection pipeline **702** and the production pipeline **706** each include multiple branches running both North to South and East to West.

[0090] As the carbon dioxide and the nitrogen are injected into the methane hydrate
30 formation via the injection pipeline **702**, the carbon dioxide and the nitrogen may move through the methane hydrate formation, as indicated by arrows **710**. This may cause the methane within the methane hydrate formation to be released. The released methane may then move in the direction of the production pipeline **706**, as indicated by arrows **712**, and be

recovered via the production pipeline 706.

[0091] The schematics of Figs. 6 and 7 are not intended to indicate that the pipeline configurations 600 and 700 shown in Figs. 6 and 7 are the only pipeline configurations that may be used according to embodiments described herein. Rather, any suitable type of pipeline configuration that provides for the distribution of nitrogen and carbon dioxide within a methane hydrate formation and the recovery of methane from the methane hydrate formation may be used according to embodiments described herein. For example, in some embodiments, the pipeline configurations 600 and 700 of Figs. 6 and 7 each include two injection pipelines 602 and 702 for separately injecting the carbon dioxide and the nitrogen into the methane hydrate formation.

Method for Power Generation and Methane Recovery from Methane Hydrates

[0092] Fig. 8 is a process flow diagram of a method 800 for power generation and methane recovery from methane hydrates. The method 800 may be implemented by any of the systems 200, 300, or 500 described with respect to Figs. 2, 3, and 5. Moreover, the method 800 may be implemented by any variation of the systems 200, 300, or 500 described with respect to Figs. 2, 3, and 5, or any suitable alternative system that is capable of integrating power generation with methane recovery from methane hydrates. Further, the method 800 may be implemented in a permafrost environment including methane hydrate formations, such as the Arctic, sub-Arctic, or Antarctica, for example.

[0093] The method 800 begins at block 802, at which power is produced via a low emissions power plant. An exhaust gas from the low emissions power plant provides a gas mixture including nitrogen and carbon dioxide.

[0094] In various embodiments, producing power via the low emissions power plant includes providing mechanical energy via an expander turbine of a gas turbine engine using energy extracted from the gas mixture after combustion of the gas mixture in a combustor and generating electricity via a generator using the mechanical energy provided by the expander turbine. Further, in various embodiments, producing power via the low emissions power plant also includes generating steam via a HRSG by heating a boiler with an exhaust stream from the expander turbine, providing mechanical energy via a steam turbine using energy extracted from the steam generated by the HRSG, and generating electricity via a generator using the mechanical energy provided by the steam turbine. In some embodiments, one common generator is used to generate electricity from the mechanical energy provided by the expander turbine and the steam turbine, while, in other embodiments, separate

generators are used.

[0095] At block **804**, methane is recovered from methane hydrates by injecting the nitrogen and the carbon dioxide from the gas mixture into the methane hydrates. In some embodiments, the gas mixture is separated into the carbon dioxide and the nitrogen, and the
5 carbon dioxide and the nitrogen are separately injected into the methane hydrates. In other embodiments, the gas mixture is injected into the methane hydrates without separating the nitrogen from the carbon dioxide within the gas mixture. In some cases, the ratio of the nitrogen to the carbon dioxide within the gas mixture is adjusted prior to injecting the gas mixture into the methane hydrates. For example, a nitrogen mole fraction of the gas mixture
10 may be adjusted, as discussed with respect to **Fig. 4**.

[0096] In some embodiments, at least a portion of the recovered methane is used as fuel for the combustor of the low emissions power plant. Further, in some embodiments, the recovered methane is purified via a separation facility to remove any impurities that were recovered from the methane hydrates along with the methane. Such impurities may include
15 water from the methane hydrates or soil from the surrounding permafrost, for example.

[0097] The process flow diagram of **Fig. 8** is not intended to indicate that the steps of the method **800** are to be executed in any particular order, or that all of the steps of the method **800** are to be included in every case. Further, any number of additional steps may be included within the method **800**, depending on the details of the specific implementation. For
20 example, in some embodiments, the nitrogen and carbon dioxide within the gas mixture are cooled prior to being injected into the methane hydrates. This may prevent the nitrogen and carbon dioxide from melting the methane hydrates upon contact.

CLAIMS

What is claimed is:

1. A system for generating power and recovering methane from methane hydrates, comprising:
 - 5 a low emissions power plant configured to generate power, wherein an exhaust gas from the low emissions power plant provides a gas mixture comprising nitrogen and carbon dioxide; and
a methane recovery system configured to recover methane from methane hydrates by injecting the nitrogen and the carbon dioxide from the gas mixture into the methane hydrates.
- 10 2. The system of claim 1, comprising a carbon dioxide separation system configured to separate the carbon dioxide from the nitrogen within the gas mixture.
 3. The system of claim 2, wherein the methane recovery system is configured to recover the methane from the methane hydrates by separately injecting the carbon dioxide and the nitrogen into the methane hydrates.
- 15 4. The system of any of claims 1 or 2, wherein the methane recovery system is configured to recover the methane from the methane hydrates by injecting the gas mixture comprising the carbon dioxide and the nitrogen into the methane hydrates without separating the nitrogen from the carbon dioxide within the gas mixture.
 5. The system of any of claims 1, 2, or 4, wherein the methane recovery system is
20 configured to adjust a ratio of the nitrogen to the carbon dioxide within the gas mixture prior to injection of the gas mixture into the methane hydrates.
6. The system of any of claims 1, 2, 4, or 5, wherein the low emissions power plant comprises:
 - 25 an expander turbine configured to provide mechanical energy by extracting energy from the gas mixture after combustion of the gas mixture in a combustor; and
a generator configured to generate electricity from the mechanical energy provided by the expander turbine.
7. The system of claim 6, wherein at least a portion of the methane recovered from the methane hydrates is flowed into the combustor as fuel.
- 30 8. The system of any of claims 1, 2, or 4-6, wherein the low emissions power plant comprises a combined cycle power plant.

9. The system of claim 8, wherein the combined cycle power plant comprises:
- an expander turbine configured to provide mechanical energy by extracting energy from the gas mixture after combustion of the gas mixture in a combustor;
 - a heat recovery steam generator (HRSG) configured to generate steam by heating a boiler with an exhaust stream from the expander turbine;
 - a steam turbine configured to provide mechanical energy by extracting energy from the steam generated by the HRSG; and
 - a generator configured to generate electricity from the mechanical energy provided by the expander turbine and the steam turbine.
10. The system of claim 9, wherein at least a portion of the methane recovered from the methane hydrates is flowed into the combustor as fuel.
11. The system of any of claims 1, 2, 4-6, or 8, wherein a portion of the gas mixture is recycled to the low emissions power plant.
12. The system of any of claims 1, 2, 4-6, 8, or 11, comprising a cooler for cooling the gas mixture prior to injection of the carbon dioxide and the nitrogen from the gas mixture into the methane hydrates.
13. The system of any of claims 1, 2, 4-6, 8, 11, or 12, wherein the low emissions power plant is configured to operate at a substantially stoichiometrically balanced condition, and wherein at least a portion of the exhaust gas is recirculated to the low emissions power plant.
14. A method for generating power and recovering methane from methane hydrates, comprising:
- producing power via a low emissions power plant, wherein an exhaust gas from the low emissions power plant provides a gas mixture comprising nitrogen and carbon dioxide; and
 - recovering methane from methane hydrates by injecting the nitrogen and the carbon dioxide from the gas mixture into the methane hydrates.
15. The method of claim 14, comprising:
- separating the gas mixture into the carbon dioxide and the nitrogen; and
 - separately injecting the carbon dioxide and the nitrogen into the methane hydrates.
16. The method of any of claims 14 or 15, comprising injecting the gas mixture into the

methane hydrates without separating the nitrogen from the carbon dioxide within the gas mixture.

17. The method of claim 16, comprising adjusting a ratio of the nitrogen to the carbon dioxide within the gas mixture prior to injecting the gas mixture into the methane hydrates.

5 18. The method of any of claims 14-16, wherein producing the power via the low emissions power plant comprises:

providing mechanical energy via an expander turbine using energy extracted from the gas mixture after combustion of the gas mixture in a combustor; and

10 generating electricity via a generator using the mechanical energy provided by the expander turbine.

19. The method of claim 18, comprising flowing at least a portion of the methane recovered from the methane hydrates into the combustor as fuel.

20. The method of any of claims 14-16 or 18, wherein producing the power via the low emissions power plant comprises:

15 providing mechanical energy via an expander turbine using energy extracted from the gas mixture after combustion of the gas mixture in a combustor;

generating steam via a heat recovery steam generator (HRSG) by heating a boiler with an exhaust stream from the expander turbine;

20 providing mechanical energy via a steam turbine using energy extracted from the steam generated by the HRSG; and

generating electricity via a generator using the mechanical energy provided by the expander turbine and the steam turbine.

21. The method of claim 20, comprising flowing at least a portion of the methane recovered from the methane hydrates into the combustor as fuel.

25 22. The method of any of claims 14-16, 18, or 20, wherein recovering the methane from the methane hydrates by injecting the nitrogen and the carbon dioxide from the gas mixture into the methane hydrates comprises:

increasing a temperature of the methane hydrates by contacting the methane hydrates with the nitrogen; and

30 dissociating the methane from the methane hydrates by contacting the methane

hydrates with the carbon dioxide, wherein the carbon dioxide replaces the methane within the methane hydrates.

23. The method of any of claims 14-16, 18, 20, or 22, comprising removing impurities from the methane recovered from the methane hydrates.

5 24. A system for recovering methane from methane hydrates using a gas mixture from a combined cycle power plant, comprising:

an expander turbine configured to provide mechanical energy by extracting energy from a gas mixture exiting a combustor, wherein the gas mixture comprises nitrogen and carbon dioxide;

10 a heat recovery steam generator (HRSG) configured to generate steam by heating a boiler with the gas mixture from the expander turbine;

a steam turbine configured to provide mechanical energy by extracting energy from the steam generated by the HRSG;

15 a generator configured to generate electricity from the mechanical energy provided by the expander turbine and the steam turbine;

a separation system configured to separate the carbon dioxide from the methane within the gas mixture; and

20 a methane recovery system configured to recover methane from methane hydrates by injecting the nitrogen and the carbon dioxide from the gas mixture into the methane hydrates, wherein at least a portion of the methane recovered from the methane hydrates is flowed into the combustor as fuel.

25 25. The system of claim 24, wherein the expander turbine is configured to operate at a substantially stoichiometrically balanced condition, and wherein at least a portion of the gas mixture is recirculated to the combustor.

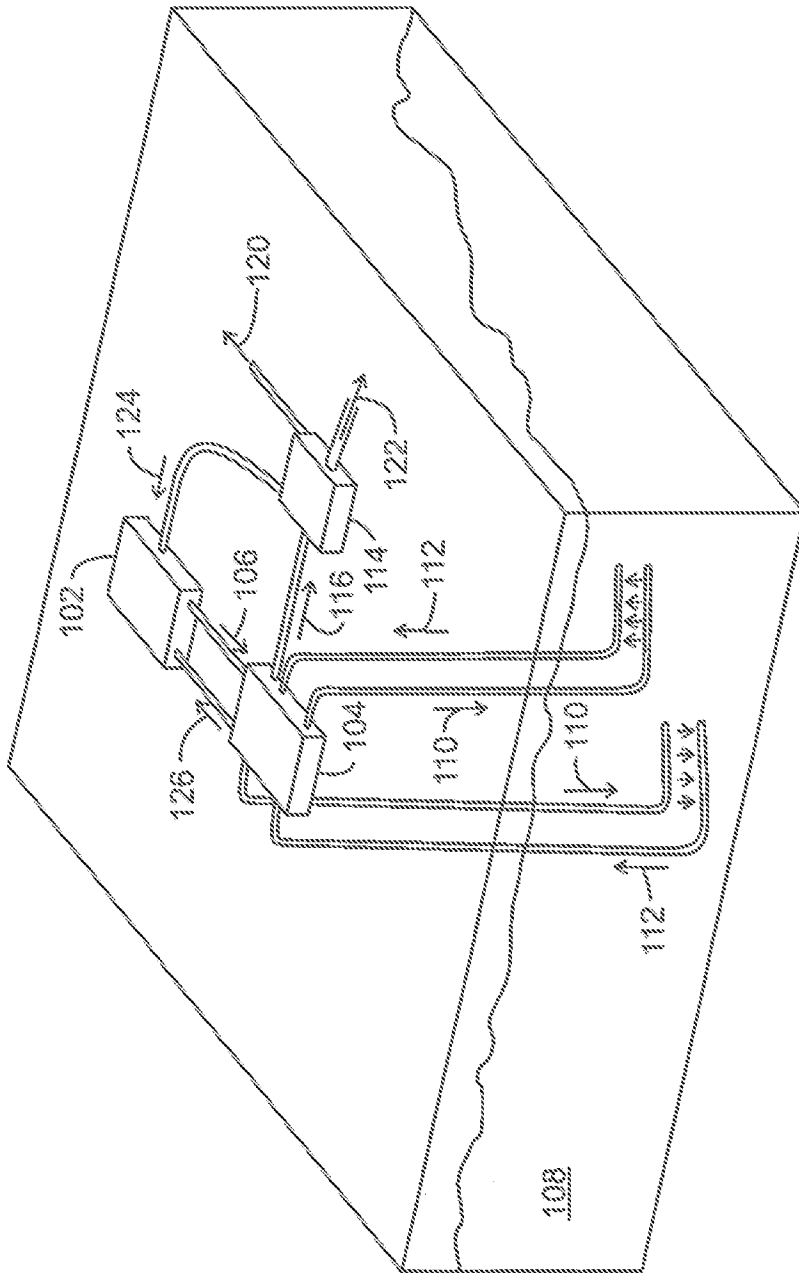

100
FIG. 1

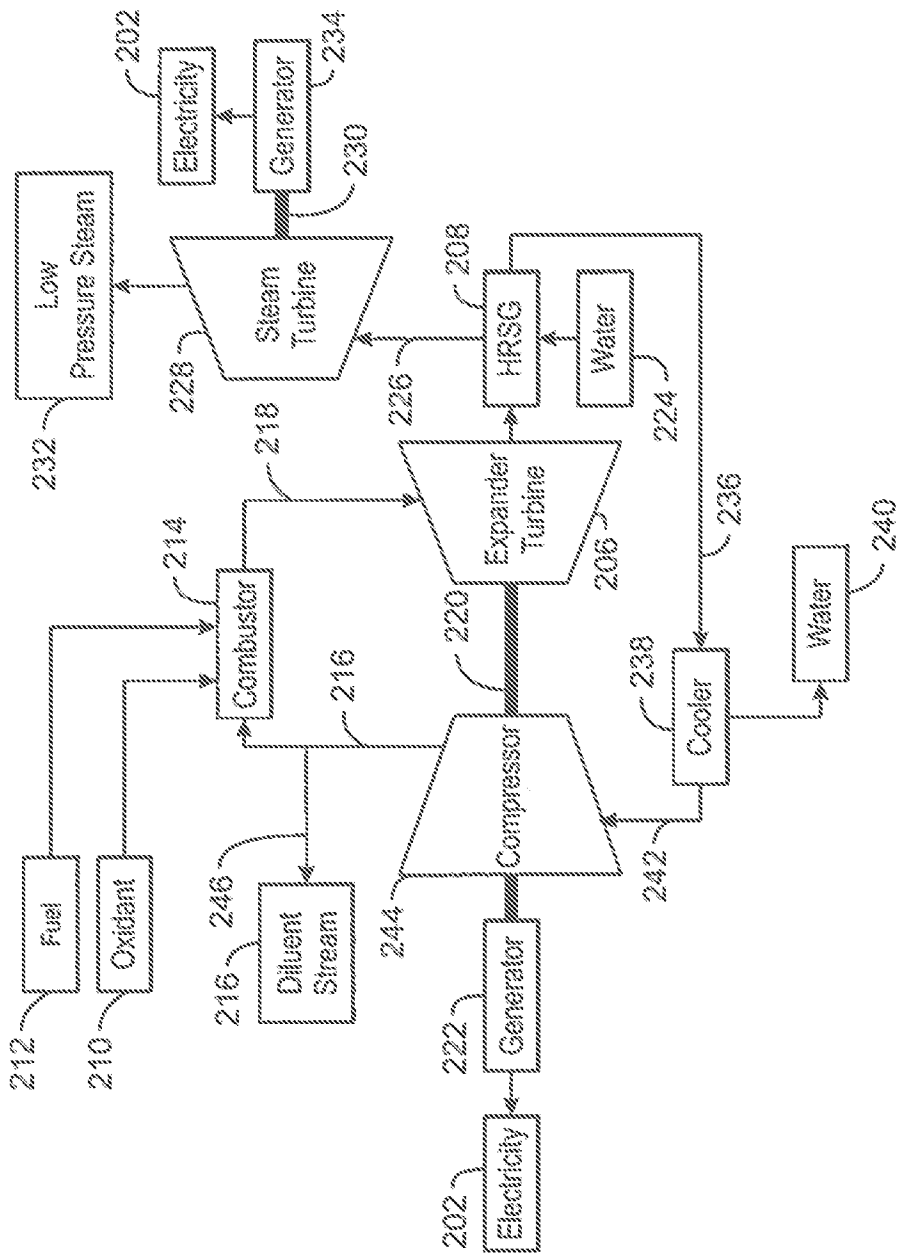

200
FIG. 2

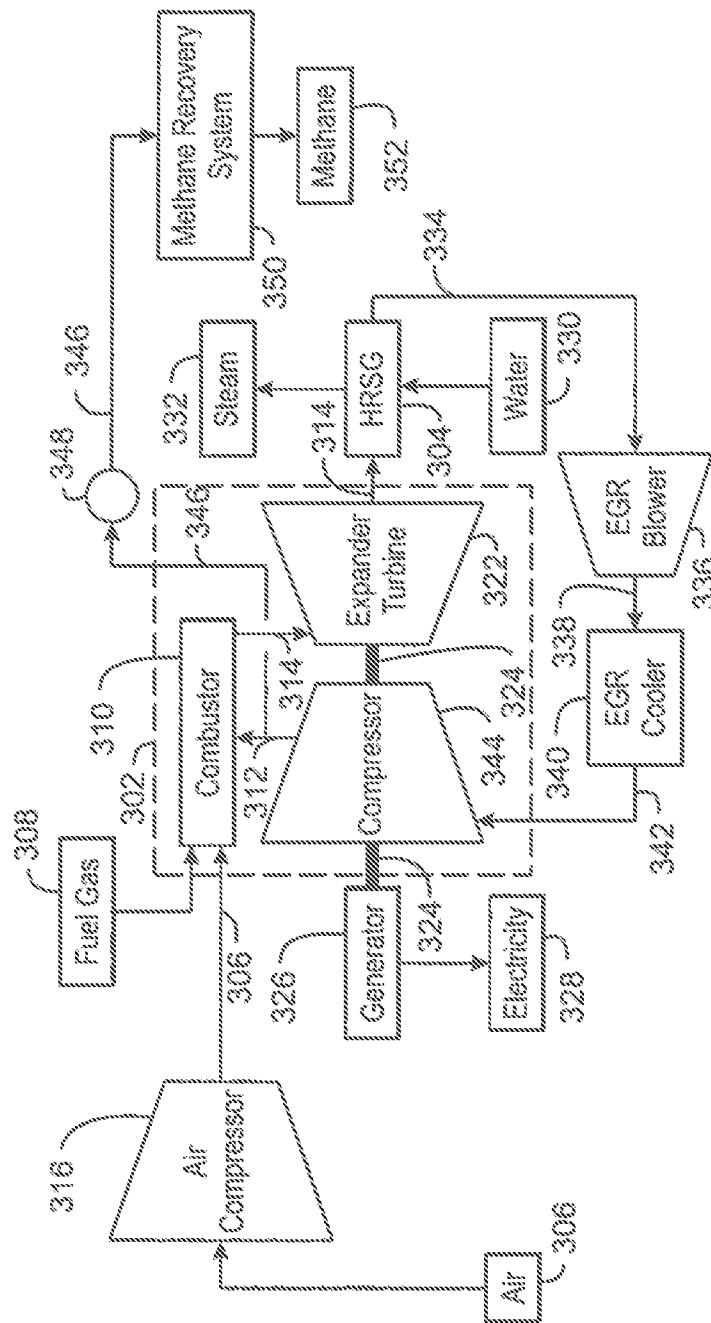

300
FIG. 3

4/8

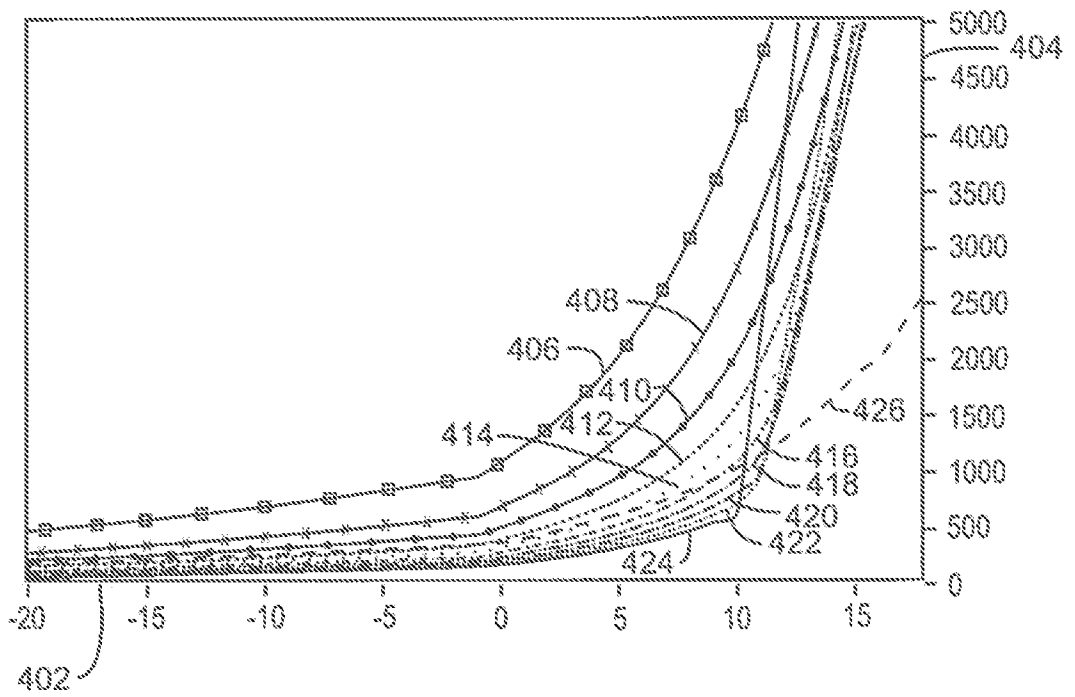

400
FIG. 4

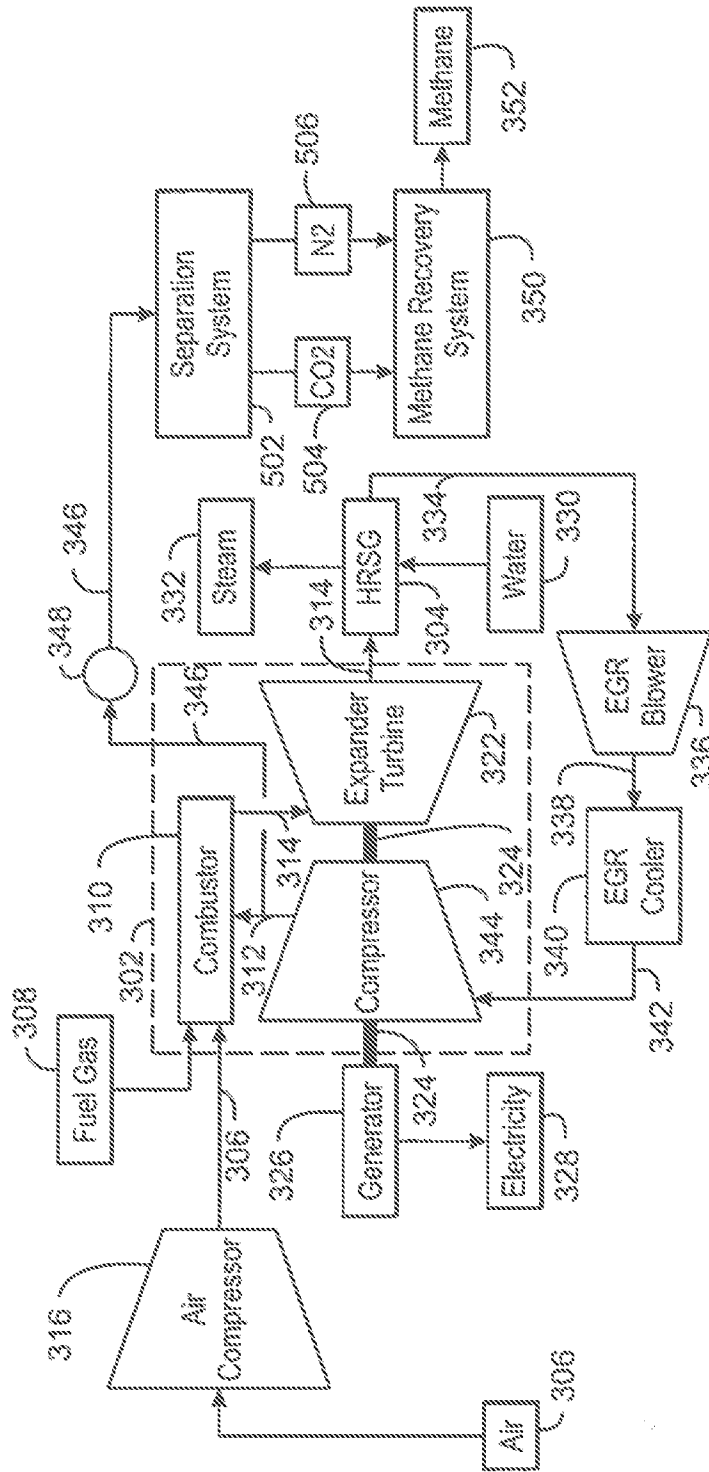

500
FIG. 5

6/8

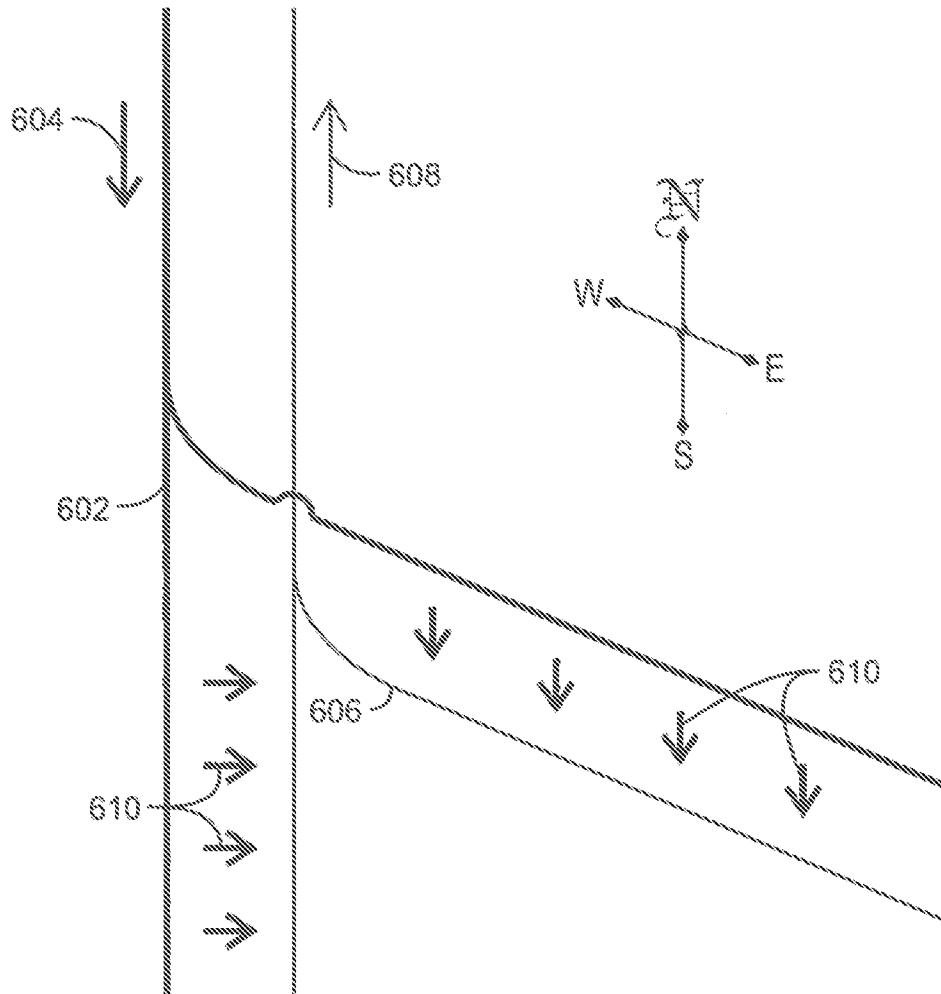

600
FIG. 6

7/8

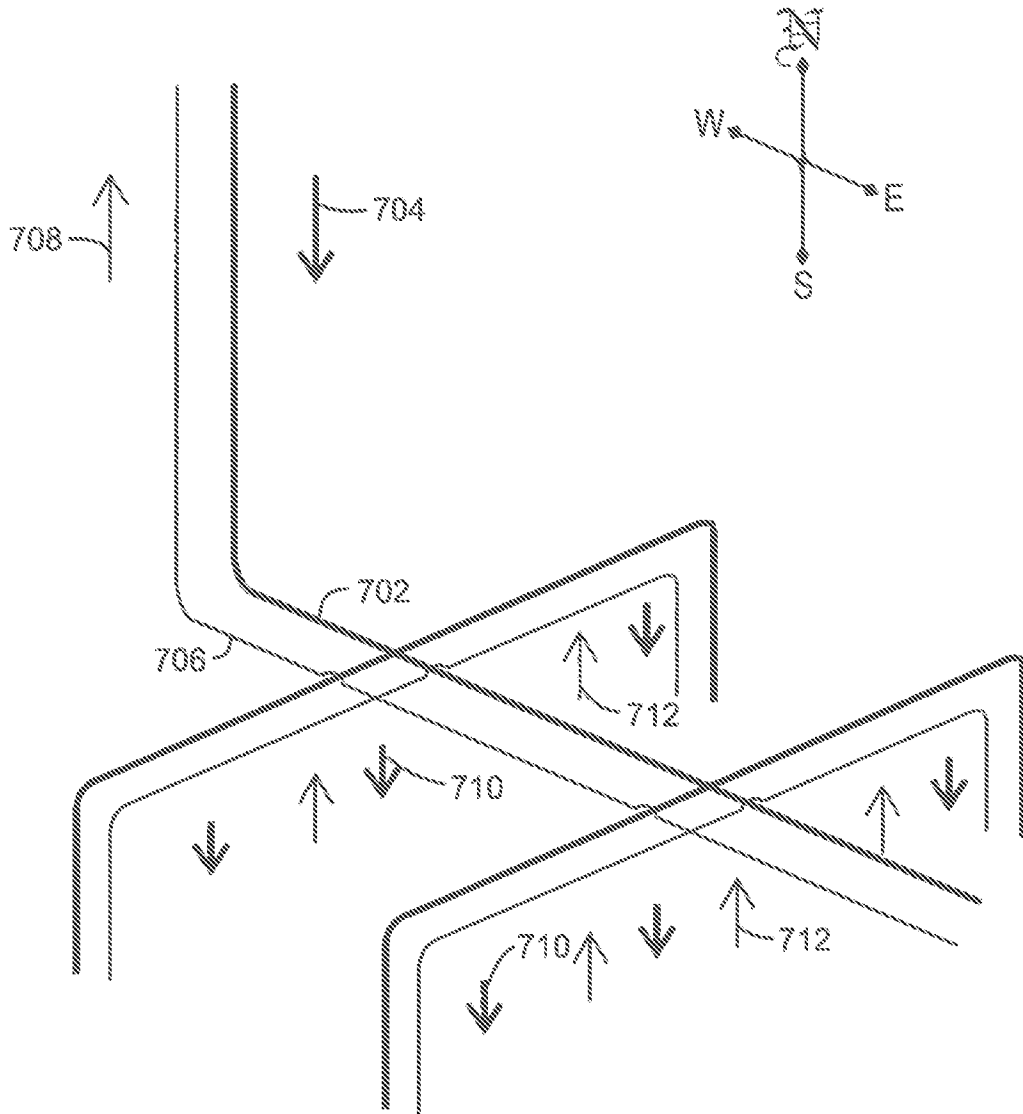

700
FIG. 7

8/8

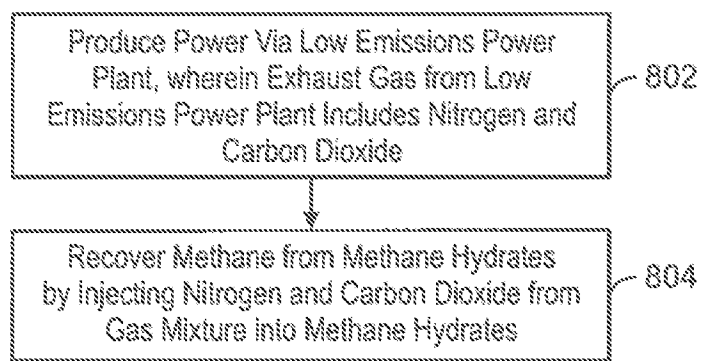

800
FIG. 8

INTERNATIONAL SEARCH REPORT

International application No
PCT/US2014/018091

A. CLASSIFICATION OF SUBJECT MATTER
INV. C10L3/10 E21B43/16
ADD.
According to International Patent Classification (IPC) or to both national classification and IPC

B. FIELDS SEARCHED
Minimum documentation searched (classification system followed by classification symbols)
C10L E21B

Documentation searched other than minimum documentation to the extent that such documents are included in the fields searched

Electronic data base consulted during the international search (name of data base and, where practicable, search terms used)
EPO-Internal, COMPENDEX, INSPEC, WPI Data

C. DOCUMENTS CONSIDERED TO BE RELEVANT

Category*	Citation of document, with indication, where appropriate, of the relevant passages	Relevant to claim No.
X	US 2008/022594 A1 (LEE HUEN [KR] ET AL) 31 January 2008 (2008-01-31) cited in the application the whole document	1-25
X	US 2012/035405 A1 (HESTER KEITH C [US] ET AL) 9 February 2012 (2012-02-09) the whole document	1-25
A	DATABASE WPI Week 200022 Thomson Scientific, London, GB; AN 2000-250145 XP002724676, & JP 2000 061293 A (TOSHIBA KK) 29 February 2000 (2000-02-29) abstract	1-25
	----- -/--	

Further documents are listed in the continuation of Box C.

See patent family annex.

* Special categories of cited documents :

"A" document defining the general state of the art which is not considered to be of particular relevance

"E" earlier application or patent but published on or after the international filing date

"L" document which may throw doubts on priority claim(s) or which is cited to establish the publication date of another citation or other special reason (as specified)

"O" document referring to an oral disclosure, use, exhibition or other means

"P" document published prior to the international filing date but later than the priority date claimed

"T" later document published after the international filing date or priority date and not in conflict with the application but cited to understand the principle or theory underlying the invention

"X" document of particular relevance; the claimed invention cannot be considered novel or cannot be considered to involve an inventive step when the document is taken alone

"Y" document of particular relevance; the claimed invention cannot be considered to involve an inventive step when the document is combined with one or more other such documents, such combination being obvious to a person skilled in the art

"&" document member of the same patent family

Date of the actual completion of the international search 21 May 2014	Date of mailing of the international search report 06/06/2014
--	--

Name and mailing address of the ISA/ European Patent Office, P.B. 5818 Patentlaan 2 NL - 2280 HV Rijswijk Tel. (+31-70) 340-2040, Fax: (+31-70) 340-3016	Authorized officer Greß, Tobias
--	--

INTERNATIONAL SEARCH REPORT

International application No
PCT/US2014/018091

C(Continuation). DOCUMENTS CONSIDERED TO BE RELEVANT		
Category*	Citation of document, with indication, where appropriate, of the relevant passages	Relevant to claim No.
A	WO 2008/136962 A1 (PRECISION COMBUSTION INC [US]; PFEFFERLE WILLIAM C [US]) 13 November 2008 (2008-11-13) paragraphs [0006], [0010]; claims 7,11, 12, 14 -----	1-25
A	US 2004/200618 A1 (PIEKENBROCK EUGENE J [US]) 14 October 2004 (2004-10-14) paragraphs [0086], [0087]; claims 1,3 -----	1-25
X	KYUCHUL SHIN ET AL: "Swapping Phenomena Occurring in Deep-Sea Gas Hydrates", ENERGY & FUELS, vol. 22, no. 5, 17 September 2008 (2008-09-17), pages 3160-3163, XP055119126, ISSN: 0887-0624, DOI: 10.1021/ef8002087 the whole document -----	1-25
X	DONG-YEUN KOH ET AL: "Recovery of Methane from Gas Hydrates Intercalated within Natural Sediments Using CO ₂ and a CO ₂ /N ₂ Gas Mixture", CHEMSUSCHEM, vol. 5, no. 8, 22 June 2012 (2012-06-22), pages 1443-1448, XP055119104, ISSN: 1864-5631, DOI: 10.1002/cssc.201100644 the whole document -----	1-25

INTERNATIONAL SEARCH REPORT

Information on patent family members

International application No

PCT/US2014/018091

Patent document cited in search report	Publication date	Patent family member(s)	Publication date	
US 2008022594	A1	31-01-2008	JP 4668933 B2	13-04-2011
			JP 2008031413 A	14-02-2008
			US 2008022594 A1	31-01-2008

US 2012035405	A1	09-02-2012	US 2012035405 A1	09-02-2012
			WO 2012021282 A1	16-02-2012

JP 2000061293	A	29-02-2000	NONE	

WO 2008136962	A1	13-11-2008	CA 2678638 A1	13-11-2008
			WO 2008136962 A1	13-11-2008

US 2004200618	A1	14-10-2004	NONE	
