

S. H. LA RUE.
Base-Burning Stove.

No. 132,211.

Patented Oct. 15, 1872.

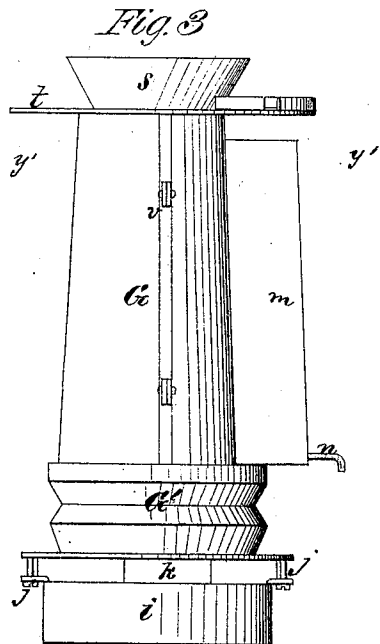
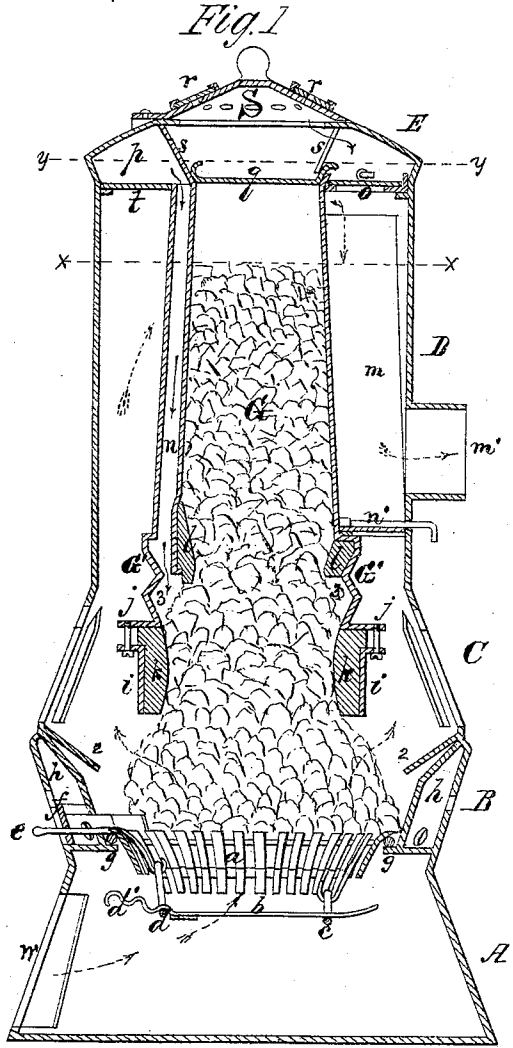

Fig. 4

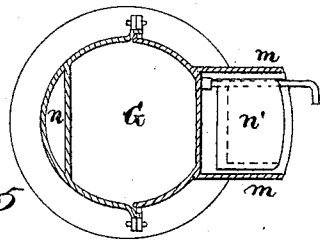

Fig. 5

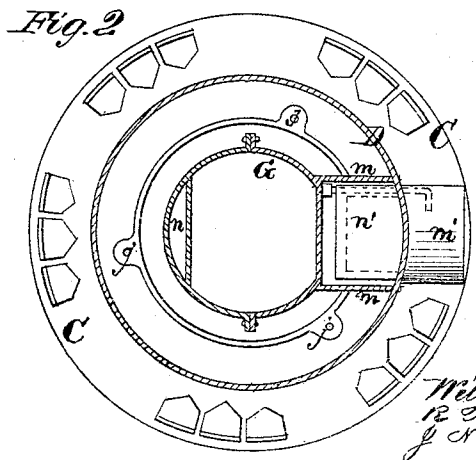
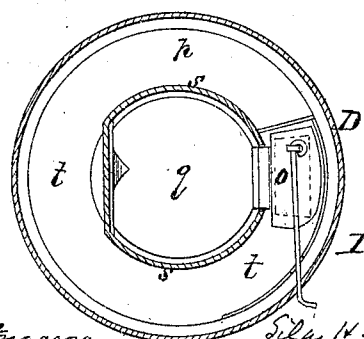

Fig. 2



Inventor

Witnesses.
R. T. Campbell.
J. H. Campbell.
Silas H. La Rue
by
M. L. ...

UNITED STATES PATENT OFFICE.

SILAS HOFFMAN LA RUE, OF ALLENTOWN, PENNSYLVANIA.

IMPROVEMENT IN BASE-BURNING STOVES.

Specification forming part of Letters Patent No. 132,211, dated October 15, 1872.

To all whom it may concern:

Be it known that I, SILAS HOFFMAN LA RUE, of Allentown, in the county of Lehigh and State of Pennsylvania, have invented certain new and useful Improvements in Magazine-Stoves; and I do hereby declare that the following is a full, clear, and exact description thereof, reference being had to the accompanying drawing making part of this specification, in which—

Figure 1 is a section taken diametrically through the stove from front to rear; Fig. 2 is a section taken horizontally through the stove in the plane indicated by dotted line *x x*, Fig. 1; Fig. 3 is a view of one side of the magazine; Fig. 4 is a section through the magazine taken in the horizontal plane indicated by dotted line *y' y'*, Fig. 3; and Fig. 5 is a section taken through Fig. 1, indicated by the dotted line *y y*, Fig. 1.

Similar letters of reference indicate corresponding parts in the several figures.

This invention relates to certain novel improvements in magazine coal-stoves wherein descending currents of air are admitted into the magazine at a point above the lowest end thereof, and at the same time air is admitted through the grate and into the fire-chamber from a point below the grate, as will be hereinafter explained.

The following description will enable others skilled in the art to understand my invention.

In the accompanying drawing, A represents the ash-pit section of the stove; B, the fire-chamber section; C, the illuminating or window section; D, the combustion-chamber section; and E, the top section, all of which parts may present the general outline represented by Fig. 1. At the upper termination of the ash-pit is an annular flange, *g*, on which is sustained a basket-grate, which is composed of inclined side bars *a* and a vertically movable bottom section, *b*, which latter is rectangular and pivoted at its rear end by an inverted stirrup, *c*, and supported at its front end by a swing-stirrup, *d*. By means of this stirrup *d* and inclined corrugated or notched arms *d'* the front of the grate-section *b* can be raised or lowered at pleasure. The rod *e*, by means of which the whole grate is vibrated horizontally, passes through a horizontally-sliding plate, *f*, which closes the oblong opening through the

front of the stove left to allow the vibration of the rod *e*. It will be seen that the front of the bottom section *b* of the grate can be lowered when necessary to remove clinkers; also that the parallel bars of the base-piece *b* are so arranged as to admit of being raked with a poker. It is open in front and rear to admit of clinkers being raked forward or pushed backward. The upwardly-flaring fire-chamber or pot B is constructed with double walls, the outer one of which is perforated to allow a free circulation of air between the walls, and the inner wall is surmounted by an inclined annular ring, 2, as shown in Fig. 1. The magazine G is terminated above in a funnel, *s*, arranged within the top section E, and closed by a removable cover, *q*, which is on a level with a diaphragm, *t*, from which the magazine is suspended. From the horizontal diaphragm *t* the magazine extends down in the center of the combustion-chamber and terminates at its lowest end within the illuminating section C. The lowest portion of the magazine is formed of fire-brick *k*, inclosed by a case, *i*, which is secured by vertical bolts *j* to a flange surrounding a shouldered portion, G'. The bricks *k* are shouldered, and are supported by these shoulders upon the upper edge of the case *i*. In front of the magazine is a descending air-flue, *n*, which forms a communication between an air-space, *p*, in the top section E, and an annular air-space, 3, within the shouldered portion G'. This air-space 3 is above the lower end of the magazine, and is formed by a contracted fire-brick lining, *l*, which rests on shoulders inside of the portion G' and above the lining *k*. The air-chamber *p* is supplied with air through a register, *r*, on a cover, S, which air enters the funnel *s* first, and thence escapes through an opening made through its rear side into the chamber *p*, and thence through the flue *n* into the annular space 3 within the magazine. By means of the register *r* the influx of air can be regulated or cut off at pleasure. At the back of the magazine are two vertical plates, *m m*, which form a flue for the escape of the products of combustion from the combustion-chamber through an exit-pipe, *m'*. The flue formed by plates *m m* is provided at its bottom with a damper, *n'*, by opening which the products of combustion will pass directly off through pipe *m'*. When damper *n'* is shut the products are compelled to

ascend as high as the diaphragm *t* before they can enter the said flue, thus heating the entire drum *D*. The body of the magazine is composed of two vertical halves secured together by close joints, lugs, and bolts or rivets, as shown in Figs. 2, 3, and 4. At a point just above the flue which is formed by strips *m m* an opening is made through the diaphragm *t* and provided with a damper or valve, *o*, by opening which more or less air will be admitted into the combustion-chamber from the annular chamber *p*, and the operation of the stove can be thus regulated to a nicety, for it will be seen that the influx of air at this point will act as a cut-off and diminish both the ascending draft through the grate and the descending draft through the flue *n* and lower portions of the magazine. It will also be seen that the introduction of air among the coal inside of the lower portion of the magazine will cause the coal below the fire-brick lining *l* to take fire and burn, the products from which will descend through the incandescent coals in the lower end of the magazine on the grate and be completely consumed; and, while this is the case, the fire-brick *l* and air-space 3 will protect the portion *G* from rapid destruction by the heat.

Having described my invention, what I claim as new, and desire to secure by Letters Patent, is—

1. The air-flue *n*, communicating at its lower end with the interior of the magazine, and at its upper end with an annular chamber, *p*, in combination with the opening through funnel *s* and a register, *r*, substantially as described.

2. The fire-brick lining *l*, forming an annular air-chamber, 3, in combination with the flue *n*, substantially as described.

3. The arrangement of damper *o* over the flue which is formed by plates *m m*, substantially as described.

4. The basket-grate, composed of sections *a b*, the part *b* being supported upon the parts *c* and *d* by means substantially as described.

5. The lower section of the magazine, composed of fire-bricks *k*, which are shouldered so that their inner surfaces are flush with the inner edge of section *G'*, and secured to this section *G'* by means of lugs on an inclosing case, *i*, and bolts *j*, substantially as described.

SILAS HOFFMAN LA RUE.

Witnesses:

W. J. HEYWORTH,
TILGHMAN GOOD.