

**EUROPEAN PATENT APPLICATION**

Application number: 88105647.7      Int. Cl.4: G07F 7/06 , G07F 7/00  
 Date of filing: 08.04.88

Priority: 08.04.87 JP 86385/87  
           08.04.87 JP 86388/87  
           08.07.87 JP 170600/87  
 Date of publication of application:  
 12.10.88 Bulletin 88/41  
 Designated Contracting States:  
 AT BE CH DE ES FR GB GR IT LI LU NL SE

Applicant: **OMRON TATEISI ELECTRONICS CO.**  
 10, Tsuchido-cho Hanazono Ukyo-ku  
 Kyoto 616(JP)  
 Inventor: **Yoshida, Shinya Omron Tateisi Electronics Co.**  
 Patent Center 20, Igadera  
 Shimo-Kaiinji Nagaokakyo-City Kyoto 617(JP)  
 Inventor: **Nakagawa, Masanao Omron Tateisi Electronics Co.**  
 Patent Center 20, Igadera  
 Shimo-Kaiinji Nagaokakyo-City Kyoto 617(JP)  
 Inventor: **Takebayashi, Hajime Omron Tateisi Electronics Co.**  
 Patent Center 20, Igadera  
 Shimo-Kaiinji Nagaokakyo-City Kyoto 617(JP)  
 Representative: **WILHELMS, KILIAN & PARTNER Patentanwälte**  
 Eduard-Schmid-Strasse 2  
 D-8000 München 90(DE)

**Automatic article renting machine.**

In an automatic article renting machine, when a customer rents a new article (e.g. videocassette), since the number of videocassettes now being rent by the customer is checked and an additional renting is prohibited when the checked number exceeds a predetermined value, it is possible to prevent limitless videocassette renting to the same customer and to urge the customer to return videocassettes. Further, since the rental fee and the rental period are adjusted according to days of the week, it is possible to make uniform the videocassette renting business through the week. Further, even when a bar code indicative of the videocassette number is defective and therefore non-readable, since the customer can return the defective videocassette by inserting an ID card and by indicating the videocassette number, it is possible to prevent the customer from paying extra rental fee.

EP 0 286 130 A2

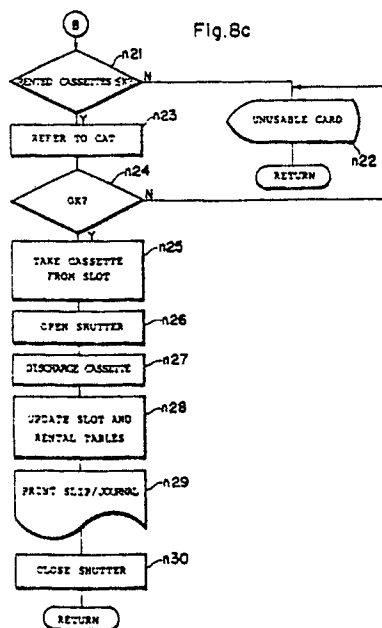

## Automatic Article Renting Machine

### BACKGROUND OF THE INVENTION

#### Field of the Invention

The present invention relates to an automatic article renting machine for automatically renting articles (e.g. a videocassette) to customers and receiving article returned from the customers.

#### Description of the Prior Art

Videocassette renting machines so far proposed are provided with a cassette accommodating shelf formed with a plurality of inner slots into which cassettes are inserted for keeping; a cassette conveying device for moving a cassette between each inner slot and an outer rental/return slot; and a slot table for recording a slot number, a cassette number and management data including rental fee. A videocassette designated or inserted by a customer is rented or returned by determining the inner videocassette slot position in the shelf and the rental fee with reference to the slot table and by moving the corresponding cassette between the inner slot and the outer rental/return slot by the cassette conveying device. In the conventional videocassette renting machines as described above, videocassettes are rented limitlessly according to customer's requirement without any restriction. Therefore, there exists a problem in that some videocassettes are not returned.

Further, in the prior-art renting machines, the rental fee is usually fixed (e.g. rental fee per night) irrespective of days of the week on which a videocassette is rented and also the rental period is fixed. However, there exists a tendency that articles are concentratedly rented on a specific day of the week. For instance, in the case of videocassettes, videocassettes are mainly rented on the weekend or not rented many on weekdays. Therefore, in a conventional renting machines, there exists a problem in that it is impossible to rent videocassettes effectively on the weekdays, because the rental fee and the rental period are both uniformly fixed.

Further, the automatic renting machines usually perform the rental/return processing as follows: a videocassette is rented to a customer after customer authentication (a customer is checked as to whether he or she is a person authorized to rent articles) with use of a card; a customer's card data and the videocassette data are both recorded so as to correspond to each other in the storage device; when the videocassette is returned, an identifica-

tion code (e.g. bar code) formed on the returned videocassette is read to retrieve data recorded in the storage device and to confirm that the returned videocassette is the one recorded in the storage device.

In the above return processing, the customer's authentication is not made, because there exists a case where a customer often returns plural videocassettes simultaneously.

In any way, it is necessary to read an identification code formed on a videocassette when returned. However, since the identification code is usually formed on the surface of the cassette casing in the form of bar code, there exists a problem in that when the bar code is damaged or stained, the code cannot be read reliably. In case the bar code on the cassette casing is not read, since no return processing is made even if the videocassette has been returned, the rental fee is accumulated and therefore an unforeseen damage is inflicted on the customer or there exists a problem in that monetary matters occur.

### SUMMARY OF THE INVENTION

With these problems in mind, therefore, it is the primary object of the present invention to provide an automatic article renting machine which can limit the number of articles including videocassettes to be rented by providing a rental table in which the number of rented articles is recorded for each customer.

It is another object of the present invention to provide an automatic article renting machine which can promote article renting business even on weekdays by providing a rental table in which rental fee and/or rental period are adjusted according to days of the week.

It is still another object of the present invention to provide an automatic article renting machine which can enable the return processing even when an identification code formed on an article cannot be read.

To achieve the above-mentioned first object, an automatic article renting machine having an article accommodating shelf formed with a plurality of inner slots into which articles are inserted; an outer article rental/return slot; an article conveying device for moving an article between each inner slot and the outer rental/return slot; and a slot table for recording an inner slot number, an article number and management data including rental fee; an inner slot position and a rental fee of an article designated or returned by a customer being deter-

mined with reference to the slot table; the designated or returned article being conveyed between the determined inner slot and the outer rental/return slot for rental/return processing; and the rental fee being paid by cash or a card, of the present invention, is characterized by rental table means for storing the number of articles now being rented for each customer; determining means for determining the number of articles now being rented of each customer from said rental table means whenever a new article is rented; and prohibiting means for prohibiting additional rental processing when the number of articles now being rented exceeds a predetermined number.

In the automatic article renting machine according to the present invention, the number of articles now being rented is checked for each customer by the rental table whenever a customer requires to rent a new article through the rental operation. When the number of articles now being rented exceeds a predetermined number, an additional renting operation is prohibited. That is, an additional article is rented only when the number of articles now being rented is below the predetermined number.

In the present invention, a rental table is provided in addition to the slot table in order to record the current number of articles being rented in this rental table for each customer. Whenever a new article is rented, since the number of articles now being rented is first checked by this rental table and a new article is prohibited from being additionally rented when the checked article number exceeds a predetermined value, it is possible to prevent articles from being rented limitlessly and therefore to prevent articles from being not returned.

To achieve the above-mentioned second object, an automatic article renting machine having an article accommodating shelf formed with a plurality of inner slots into which articles are kept; an outer article rental/return slot; an article conveying device for moving an article between each inner slot and the outer rental/return slot; and a management table for recording rental fee or rental period for each article to be rented; an article designated or returned by a customer being conveyed between the inner slot and the rental/return slot for rental/return processing; and rental fee being paid by cash or card, of the present invention, is characterized by a rental fee table in which rental fees are adjusted according to days of the week; a rental period table in which rental periods are predetermined for each day of the week; operation mode selecting means for selecting any one of the two tables; a calendar clock for counting days of the week; and determining means for determining a today's rental fee or a today's rental period in said management table

with reference to the table selected by said operation mode selecting means and a day of the week of the calendar clock.

In the automatic article renting machine according to the present invention, the today's day of the week is always checked by the calendar clock for counting days of the week. When an article is rented, a rental fee or a rental period corresponding to a today's day of the week checked by the calendar clock is read from the rental fee table or the rental period table. In this case, any one of the two tables have been selected by the operation mode selecting means. If the mode where the rental fee table is used has been selected, a rental fee corresponding to a day of the week on which an article is rented is read. On the other hand, if the mode where the rental period table is used has been selected, a rental period corresponding to a day of the week on which an article is rented is read. The read rental fee or period is set to the management table and used in paying rental fee.

According to the present invention, since a table in which rental fees or rental periods are adjusted according to days of the week is used, when the values in the table are selected appropriately, it is possible to adjust the renting frequency on each day of the week according to the machine owner side. Therefore, it is possible to simply promote the rental business on weekdays in particular, or to make uniform the rental business through a week.

To achieve the above-mentioned third object, an automatic renting article machine in which a customer data read from an inserted customer card and an identification code formed on an article to be rented or a code related to an article to be rented are recorded as rental data before article rental operation; and an identification code formed on a returned article is read to perform a return processing on the basis of the rental data corresponding to the identification code, of the present invention, is characterized by means for allowing the customer card to be inserted when an identification code formed on a returned article is not readable; means for allowing a data for identifying the returned article to be inputted; means for performing an article return processing on the basis of a rental data specified by the customer data recorded on the inserted customer card and the inputted article identifying data; and means for inhibiting an article whose identification code is not readable from being rented again.

In the automatic article renting machine according to the present invention, a data on a customer and an article identifying code are recorded in correspondence to each other whenever an article is being rented. In case article return processing cannot be implemented by reading an article

5

10

15

20

25

30

35

40

45

50

55

identifying code when an article is being returned, the customer card is allowed to be inserted and an identifying data of an article to be returned is allowed to be entered. On the basis of these data, article return processing can be performed, and therefore a problem in that return processing is disabled because of no identification code reading can be solved.

As described above, in the automatic article renting machine according to the present invention, article return processing can be performed by inserting a customer card and inputting an article identifying data when an identification code formed on an article is not readable. In other words, even if a bar code is not read, it is possible to implement return processing, thus preventing the rental fee of the article required from being accumulated without article return.

#### BRIEF DESCRIPTION OF THE DRAWINGS

Fig. 1 is an outer diagrammatical view showing a videocassette renting machine;

Fig. 2 is a rear-side perspective view showing a videocassette;

Fig. 3 is a schematic block diagram showing an electric configuration of the renting machine;

Fig. 4 is a diagram showing a memory map;

Fig. 5 is a plan view showing a memory card;

Fig. 6 is a perspective view showing a cassette take/restore mechanism;

Fig. 7a is a diagram showing an IC memory map;

Fig. 7b is a diagram showing a slot table;

Fig. 7c is a diagram showing a rental table;

Figs. 8a to 8g are flowcharts for assistance in explaining the operations of the videocassette renting machine of the present invention;

Figs. 9 to 14b show another embodiments of the present invention;

Fig. 9 is an outer diagrammatical view showing a videocassette renting machine;

Fig. 10 is a schematic block diagram showing an electric configuration of the renting machine;

Fig. 11 is a diagram showing a memory map;

Fig. 12 is a diagram showing a management table;

Fig. 13a is a diagram showing a rental fee table;

Fig. 13b is a diagram showing a rental period table;

Figs. 14a and 14a are flowcharts for assistance in explaining the operations of the videocassette renting machine of the present invention;

Figs. 15a to 16c shown another embodiments of the present invention;

Fig. 15a is a videocassette data file set in a memory unit of a control section of the videocassette renting machine;

Fig. 15b is a rental file set in a memory unit of the control section of the videocassette renting machine;

Figs. 16a to 16c are flowcharts for assistance in explaining the operation of the videocassette renting machine;

Fig. 16a is a mainroutine thereof;

Fig. 16b is a renting processing subroutine thereof; and

Fig. 16c is a return processing subroutine thereof.

#### DETAILED DESCRIPTION OF THE PREFERRED EMBODIMENTS

##### FIRST EMBODIMENT

Fig. 1 is an outer diagrammatical view showing an embodiment of videocassette renting machine according to the present invention, by which the number of videocassettes to be rented for each customer can be limited. On the front side of the machine 1, there are arranged a cathode ray tube (CRT) 2, a card insertion slit 3, a bill insertion slit 4, a coin insertion slit 5, a mode selection key 6, a money change chute 7, a slip slit 8, an outer videocassette rental/return slot 9 and a videocassette selection keys 10.

The CRT 2 displays operation messages to the customer. Through the card insertion slit 3, ID (identification) cards such as credit cards, member cards or other cards are inserted. When rental fee is paid by cash, bills and coins are inserted through the bill insertion slit 4 and the coin insertion slit 5. The mode selection key 6 is composed of a rental key used to rent a videocassette and a return key used to return a videocassette.

Change (money) is discharged through the change chute 7 when change is necessary in rental fee payment. A receipt slip is discharged through the slip slit 8 in rental fee payment. In the rental mode, a videocassette required for a customer is conveyed from an inner slot 50a (described later) to the outer videocassette rental/return slot 9 for discharging the videocassette. In the return mode, a videocassette to be returned by the customer is put into this outer videocassette rental/return slot 9. As will be described later in more detail, a cassette take/restore mechanism (conveying device) is provided for conveying a videocassette between each of plural inner videocassette keeping slots arranged within the machine and this outer rental/return slot

9.

The videocassette selection key 10 is composed of a plurality of keys. Each key corresponds to each cassette number. A cassette title is displayed on top of each key. Further, it is also possible to select any desired cassette by entering a cassette number or a slot number at which the desired cassette is kept. Further, where two or more cassettes of the same title are kept, a single selection key can be assigned to a plurality of cassette numbers.

Fig. 2 is a back side perspective view of a videocassette. As shown, a bar code 11 representative of a videocassette number (identification code) is printed or adhered to a back end surface of the videocassette. A bar code reader is provided for the cassette take/restore mechanism moved between the inner slots 50a and the outer slot 9. The above bar code 11 can be read by the bar code reader when a videocassette is held in this cassette take/restore mechanism. The videocassette number is assigned to each cassette even if the cassette title is the same to plural cassettes to be kept or stored.

Fig. 3 is a block diagram showing an electric configuration of the videocassette renting machine. To a CPU 20, there are connected a memory 21 made up of ROM and RAM, a rental device input/output (I/O) interface 22, a videocassette selection key input/output interface 23, a CRT input/output interface 24, a card reader input/output interface 25, a cash processing input/output interface 26, a printer input/output interface 27, a CAT (card authorization terminal) input/output interface 28 via a bus. The videocassette selection key 10 is connected to the selection key I/O 23; the CRT 2 is connected to the CRT I/O 24; a card reader 30 is connected to the card reader I/O 25; a bill payment processing device 31 and a coin payment/change processing device 32 are connected to the cash processing I/O 26; a receipt/journal printer 33 is connected to the printer I/O 27, respectively. Further, a credit center (not shown) is connected to the CAT I/O 28 via lines. Further, the cassette take/restore mechanism 35 (conveying mechanism), an outer rental/return slot shutter mechanism and a bar code reader 34 are connected to the rental device I/O 22.

The bill payment processing device 31 processes a payment by bills inserted through the bill insertion slit 4. The coin payment/change processing device 32 processes a payment by coins inserted through the coin insertion slit 5 and calculates change to be returned to the customer. The cassette take/restore mechanism 35 (i.e. the cassette conveying device) conveys a cassette between each of plural inner slots arranged within the rental machine and the outer cassette rental/return

slot 9. The outer rental/return slot shutter mechanism 36 opens or closes a shutter 60 provided behind the outer videocassette rental/return slot 9. The shutter 60 is so controlled as to be opened where necessary. The bar code reader 34 is provided for the cassette take/restore mechanism 35 to read a bar code 11 printed on the back surface of a cassette now being returned. The card reader 30 is provided with a magnetic head for reading a customer's ID card (e.g. credit card) and further with a terminal for reading a memory card described later.

Fig. 4 shows a part of map of the memory 21, in which a system program is stored in an area M1; application programs for executing rental business or return business are stored in an area M2; an area M3 is used as work area; a slot table is stored in an area M4; and a rental table is stored in an area M5.

Fig. 5 shows a plan view showing a memory card to be inserted through the card insertion slit 3, whose data can be read by the card reader 30. This memory card is provided with a non-volatile IC memory 41 to which data can be written electrically. Further, data can be read from or written in the IC memory 41 through contacts 40 by use of a personal computer (not shown). When data written on the memory card is read by the card reader 30, the data stored in the IC memory 41 is set to the slot table M4 of the memory 21 of the renting machine. Further, data stored in the IC memory 41 include management data blocks which correspond to all the videocassette selection key numbers as described later, and a change flag is attached to the end of each block. Only the blocks each having a change flag "1" are to be changed as management data. Therefore, in the renting machine, when the memory card is read, only the management data blocks having a change flag "1" are rewritten.

Fig. 6 shows the structure of the cassette take/restore mechanism. A videocassette accommodating shelf 50 is divided into 100 slots 50a (10 rows x 10 columns) and a single videocassette can be accommodated in each slot 50a. Therefore, 100 videocassettes can be stored in this shelf 50. Each videocassette is taken or restored at a vertical videocassette position as shown in Fig. 2.

Two horizontal rails 57 are disposed in front of the accommodating shelf 50 and on the upper and lower sides. Two guide plates 59 are slidably mounted on these two horizontal rails 57. These guide plates 59 are connected to belts 55 driven by a motor 56 and a shaft 58 which transmits a driving power of a motor 56, so as to be moved in the horizontal direction when the motor 56 is rotated.

The upper and lower guide plates 59 are mounted on the upper and lower portions of two

vertical rails 54. A videocassette conveying unit 51 is coupled to these vertical rails 54 so as to be slidable up and down. This videocassette conveying unit 51 is driven in the vertical direction by a motor 52 mounted on the upper guide plate 59 and a belt 53. That is, the videocassette conveying unit 51 can be moved to any desired positions at which all the inner slots 50a of the videocassette accommodating shelf 50 and the outer videocassette rental/return slot 9 are arranged by driving the motors 56 and 52 appropriately.

The videocassette conveying unit 51 is formed into a square cylindrical shape, so as to hold a videocassette therein, with one opening end thereof open to the videocassette accommodating shelf 50 and with the other opening end thereof open to the front panel side. Although not shown, a motor and a conveyer belt are provided within the conveying unit 51 in order to take/restore a cassette from or to an inner slot 50a of the accommodating shelf 50 and also to discharge/take a cassette to or from the rental/return slot 9. Further, the bar code reader 34 is disposed on the inner upper portion of the conveying unit 51 in order to read a bar code 11 printed on the back side surface of the cassette.

The rental/return slot shutter 60 is disposed in back of the rental/return slot 9 so as to be opened or closed. When this shutter 60 is closed, it is impossible to completely insert a videocassette through the rental/return slot 9 and to discharge a videocassette from the conveying unit 51 to the rental/return slot 9.

Fig. 7a shows an IC memory map of the memory card. The number of blocks is 100 which corresponds to the sum total number of the cassette selection keys. Each block is composed of a key number (videocassette selection key number), a title name, a cassette number, a slot number, a rental fee and a change flag. The block with a change flag "1" can be changed. These data can be written by a personal computer (not shown).

Fig. 7b shows a slot table set in the memory 21 of the renting machine. The number of blocks is 100, which corresponds to the total number of videocassette selection keys. Each block is composed of a key number, a title name, a cassette number, a slot number, a rental fee, a rental flag and a non-rental flag. These management data of each block are looked up in rental or return operation. For instance, when the cassette selection key (number 2) is depressed in rental operation mode, the videocassette conveying unit 51 is moved to a slot position (slot number) corresponding to the depressed selection key 2 by looking up this slot table. Further, when rental fee is calculated, the corresponding rental fee can be known by looking up this slot table. In return operation mode, a bar code (cassette number) of the cassette returned by

a customer is read and a slot position corresponding to the cassette number is determined by looking up this table. In this way, the rental or return operation can be implemented by looking up the management data in the slot table.

Fig. 7c shows a rental table, which is formed whenever a rental operation is implemented. Each block is composed of a cassette number, a rental data, an ID number and a rental fee. This ID number is here a customer's account number or customer's ID number recorded on a credit card or other ID cards.

The operation of the above videocassette renting machine will be described hereinbelow with reference to flowcharts shown in Figs. 8a to 8g.

When the power supply is turned on, the initialization is performed (in step n1) and "Select mode" is displayed (in step n2). Control stands by an interrupt caused by a mode selection key 6, a clerk key (not shown) provided in the machine or a timer interrupt provided in the CPU 20 (in steps n3 to n5). When the mode selection key is depressed, control proceeds to the rental/return operation (in step n6). When a clerk key is depressed, control proceeds to the videocassette replacement operation (in step n7). Further, when the timer interrupt occurs, control proceeds to the rental table updating operation (in step n8). The timer interrupts can be determined at any time. In this embodiment, however, the timer interrupt occurs at 0 and 12 o'clock every day.

#### Rental operation

When the mode selection key 6 is depressed, control proceeds to the operation shown in Figs. 8b and 8c. Since the mode selection key 6 is composed of the rental key and the return key, control checks which key is depressed first (in step n10). If the rental key, control proceeds to the operation of steps n11 and after. First, "Select videocassette" is displayed to urge the customer to depress the cassette selection key 10. If any one of the videocassette selection key 10 is depressed (in step n12), a management data block corresponding to the depressed key number is retrieved from the slot table (in step n13). When the rental flag of the retrieved block is "1" (in step n14), since this videocassette is now being rented, "Cassette is in rental, Select again" is displayed (in step n15) and control returns to the original step. When the rental flag of the corresponding block is "0", "Insert card" is displayed to urge the customer to insert a credit card or other ID card (in step n16). After the card has been inserted (in step n17), control checks whether the inserted card is correct or not (in step n18). If the card is not correct, "Unusable

card" is displayed (in step n19) and control returns to step n2. If a correct card is confirmed (in step n18), control searches and counts the total number of cassettes rented to the customer of the ID number (or account number) read from the inserted card in the rental table (in step n20). If the total number of the same ID number stored in the rental table (i.e. the total number of videocassettes rented to the owner of this card) exceeds a predetermined value K (in step n21), "Unusable card" is displayed to limit the number of videocassettes to be rented for the same customer (in step n22), returning to the original step n2. When the number of videocassettes rented is below a predetermined value K, control refers to CAT (card authorization terminal) as to the credit of this card owner (in step n23). If not OK (in step n24); that is, if the ID number (account number) of this card is listed in a negative (black)list of the credit center, control proceeds to step n22 to display that the card is not usable.

If OK (in step n24), control moves the videocassette conveying unit 51 to an inner slot position which is given by the management data block retrieved in step n13 to take a videocassette from the inner slot (in step n25). Thereafter, the shutter 60 is opened (in step n26); the conveying unit 51 is moved to the outer videocassette rental/return slot 9 to discharge the videocassette therethrough (in step n27). Consecutively, the slot table and the rental table are updated (in step n28). That is, the rental flag of the corresponding management data block of the slot table is set to "1" and a new block is added to the rental table. This block is composed of the cassette number rented, the rental date, the ID number of the customer and the rental fee. Next, a slip and a journal are printed and the slip is discharged (in step n29) and the shutter 60 is closed again (in step n30) to complete the rental operation. In the above rental operation, it is also possible to allow the customer to insert some deposit fee.

#### Return operation

When the mode selection key is depressed in step n3 of the idle routine shown in Fig. 8a and the depressed key is a return key, the return operation shown in Figs. 8d and 8e (steps of n40 and after) will be implemented. First, "Insert card" is displayed to urge the customer to insert a credit card or other ID card (in step n40). When a card is inserted, control checks whether the ID number in the card data is recorded in the rental table (in steps n41 and n42). If not, "Not registered" is displayed (in step n43), control returns to the idle routine. If yes (in step n42), the shutter 60 is opened (in step n44) and then "Insert videocas-

sette" is displayed (in step n45). When a videocassette is inserted into the outer rental/return slot 9 (in step n46), the bar code (cassette number) of the inserted videocassette is read by the bar code reader 34 (in step n47). When read correctly (in step n48), the videocassette is conveyed and returned to the shelf (in step n49). In this step, the cassette slot position in which the returned cassette is to be restored is determined by retrieving a management data block corresponding to the read cassette number from the slot table. Then, a rental fee is calculated on the rental table (in step n50) and "Insert fee" is displayed (in step n51). When fee is paid, the fee is settled (in step n52). In the case of credit, no cash is inserted. After fee settlement, the slot table and the rental table are updated (in step n53). That is, the rental flag of the corresponding management data block is reset to "0" in the slot table. Further, the corresponding block is deleted in the rental table (in step n53). A receipt slip and journal are printed and the slip is discharged (in step n54) and the shutter 60 is closed (in step n55), returning to the original idle routine.

When the cassette number cannot be read correctly (in step n48), control proceeds to steps n60 and after. First, "Insert videocassette correctly" is displayed (in step n60) and then "Enter videocassette number" is displayed to urge the customer to enter the cassette number (in step n61). In this step, the cassette selection key 10 is used to input the cassette number. When the cassette number is inputted (in step n62) and the videocassette is inserted (in steps n63 and n64), control restores the videocassette to the corresponding slot or other collection slot without reading the cassette number (in step n65) and calculates fee on the basis of the rental table (in step n66).

The non-rental flag of the corresponding management data block is set (in step n67). Thereafter, control proceeds to fee settlement processing of steps n51 and after.

In the above processing, only when the corresponding ID number is present in the rental table, since the shutter 60 is opened (in step n44) and then closed after return operation (in step n55), the shutter 60 is kept closed where not necessary, so that it is possible to prevent an incorrect videocassette from being inserted into the outer rental/return slot 9 naughtily.

#### Videocassette exchange operation

When a clerk key provided in the machine is depressed in the idle routine, control proceeds to step n7 from step n4 to implement videocassette

exchange operation. Fig. 8f shows this exchange operation. First, "Insert memory card" is displayed to urge the clerk to insert a memory card through the card insertion slit 3 (in step n70). The clerk previously sets data as shown in Fig. 7a in the memory card by use of a personal computer. When the clerk inserts this memory card into the card insertion slit 3, the card reader 30 reads data stored in the IC memory 41 via contacts 40 of the memory card. Each block at which a change flag is set to "1" is rearranged in the slot table (in step n71). That is, the blocks at which the change flag is set to "1" are rewritten. For instance, in the example shown in Fig. 7a, the change flags of the key numbers 1 and 2 are set to "1", the corresponding blocks in the slot table are changed. That is, the cassette number of the key number 1 is changed from 1001 to 1002 and the rental fee of the key number 2 is changed from Y600 to Y700. The above-mentioned processing is implemented for all blocks where a change flag is set to "1". Thereafter, control returns to the original idle routine.

#### Rental table update operation

In the idle routine shown in Fig. 8a, if timer interrupt occurs, control proceeds to rental table update operation (in step n8 in Fig. 8a). Fig. 8g shows this operation. As already explained, timer interrupt occurs at 0 and 12 o'clock everyday. The same operation is repeated everyday at this time. The rental table is read (in step n80) and control checks whether each block is less than the maximum rental period (in step n81). For instance, a block exceeding 7 days (i.e. the maximum rental period) from the rental date is deleted (in step n82) and printed in journal (in step n83). After all blocks in the rental table are checked as described above (in step n84), this operation ends.

In the above-mentioned rental table update operation, since the blocks exceeding the maximum rental period are automatically deleted, it is possible to avert a problem in that videocassettes to be rented cannot be accommodated in the rental table, thus reducing the capacity of the memory. In addition, since the deleted blocks are printed on the journal, it is possible to manage videocassettes exceeding the maximum rental period on the basis of this printed results on the journal. Further, since only blocks within the maximum rental period are stored in the rental table, it is also possible to shorten the retrieval time in the above step n41.

## SECOND EMBODIMENT

An embodiment which can adjust rental fees and/or rental periods according to days of the week will be described hereinbelow.

Fig. 9 shows an outside view of this videocassette renting machine. Although there exists a little difference from that shown in Fig. 1, the same elements are designated by the same reference numerals without repeating the description thereof.

The card reader 30 of this embodiment allows the rental fee to be settled by credit. A keyboard 12 includes secret number entry keys, a return key, a mode selection key, etc.

Fig. 10 shows a schematic block diagram of this embodiment, which is almost the same as that shown in Fig. 3. The devices 31, 32 and 26 for handling cash (shown in Fig. 3) are not connected. The selection switch 10 and the keyboard 12 are connected to the selection key I/O interface 23. A calendar clock 29 is connected to the CPU 20.

Fig. 11 shows a map of the memory 21. In comparison with that shown in Fig. 4, areas M6, M7 and M8 are provided in place of the areas M4 and M5. A management table (described later) is set in the area M6. A rental fee table and a rental period table are set in the areas M7 and M8, respectively. Among these tables, the rental fee table and the rental period table are rewritable through the keyboard 12.

Fig. 12 shows a management table set in the area M6 of the memory 21. The numbers (No.) denote each switch number of videocassette selection switch 10. In this management table, there are provided a title name, a cassette number, a slot number, a rental fee, a rental period and a rental data for each selection switch number. Further, a rental flag is attached. When this rental flag is "1", this indicates that the cassette corresponding to the selection switch number is in rental state. Fig. 12 indicates that the videocassette corresponding to No. 1 is now being rented; the rental date is January 9th, 1987; the rental period is two days; the rental fee is Y300; the slot number is 001; the cassette number is 1001; the title name is A. Further, CPU implements rental fee settlement with reference to this table in rental/return operation.

Fig. 13a shows a rental fee table set to the area M7 of the memory 21 and Fig. 13b shows a rental period table set to the area M8 of the memory 21. These tables can be changed freely by the machine owner side through the keyboard 12. This rental fee table stores rental fees according to days of the week. For instance, the rental fee on Monday is Y300 and that on Saturday is Y500. The rental period table shown in Fig. 13b stores rental periods according to days of the week. For instance, the rental period on Monday is 3 days, and that on

Saturday is 1 day. The videocassette renting machine is operated on the basis of any one of these tables. On the basis of the selection table, the CPU reads the rental fee or the rental period according to the rental day of the week and sets the fee or the period in the management table.

Figs. 14a and 14b are flowcharts for assistance in explaining the operation of the videocassette renting machine.

At first, control stands by a business selected by a business selection key included in the keyboard 12 (in step n91). This business selection key is composed of a return processing key and a rental processing key. When the return processing key is depressed (in step n92), the return processing can be implemented (in step n93). When the rental processing key is depressed (in step n94), "Select desired cassette" is displayed on the CRT display 2 to urge the customer to select a videocassette (in step n95) and control stands by the depression of the videocassette selection switch 10 (in step n96). Then, control checks whether the operation mode is the rental fee table operation mode or the rental period table operation mode (in step n97). This mode setting can be made with a switch (not shown) provided in the machine. When the rental fee table operation mode (fee mode) is selected, control reads a rental fee corresponding to a today's day of the week with reference to the table shown in Fig. 13a and sets the fee to the fee area in the management table (in step n98). Further, a previously determined constant rental period (e.g. 2 days) is set to the period area in the management table and a today's date is set to the rental date area (in step n99).

When the rental period table operation mode (period mode) is selected, control reads a rental period corresponding to a today's day of the week with reference to the table shown in Fig. 13b and sets the period to the period area in the management table (in step n100). Further, a previously determined constant rental fee (e.g. Y300) is set to the fee area in the management table and a today's data is set (in step n101). Consequently, the corresponding rental flag is set (in step n102) and the cassette take/restore mechanism 35 is driven to process the rental operation (in step n103). Further, the credit fee is settled on the basis of the data recorded on the credit card (in step n104), returning to the original step n1.

As described above, the machine owner can select any one of the fee mode and the period mode as the operation mode and rental fee or rental period can be changed according to a day of the week in each mode. Therefore, when these fee and period are selected to appropriate values, it is possible to prevent many videocassettes from being rented on a specific day of the week, and

therefore it is possible to make uniform the videocassette renting business or processing.

Further, in the above embodiment, a rental fee table and a rental period table are prepared and any one of these two tables is used. Without being limited thereto, however, it is of course possible to use a table in which the rental fee and the rental period can be both changed according to days of the week. Further, it is also possible to provide any one of the rental fee table and the rental period table.

### THIRD EMBODIMENT

Finally, an embodiment which can permit the return operation even when the identification code of a videocassette cannot be read will be described hereinbelow in detail. Figs. 1, 2, 3 and 6 are applicable to this embodiment without modification.

In Fig. 6, a slot row 50b located at the lowermost position of the inner slots 50a of the videocassette accommodating shelf 50 is designated as slots for accommodating defective videocassettes. Therefore, all cassettes whose bar codes cannot be read are arranged in these slots.

Figs. 15a and 15b show a videocassette data file and a rental file prepared in place of the areas M4 and M5 (shown in Fig. 4) of the memory 21 of the renting machine. In this videocassette data file shown in Fig. 15a, videocassette numbers, the titles, the rental flags indicative of whether the cassette is in rental, numbers of the inner slots at which cassettes are placed when not rented, the customer's ID codes to whom the videocassettes are rented, and the rental fees are stored. The rental flag is set to "0" when not rented or accommodated but to "1" when rented or not accommodated, and further to "2" when returned without reading the bar code and accommodated in a defective cassette accommodating slot 50b (renting is prohibited).

In the rental file shown in Fig. 15b, the rental dates, the return dates, the customer's codes, the customer's secret numbers, the cassette numbers and the cassette titles are recorded in the order of renting.

The operation of the videocassette renting machine will be described with reference to the flowchart shown in Fig. 16a. This flowchart is a main routine. Control determines that the rental key is depressed (in step n111) or the return key is depressed (in step n112). If the rental key is depressed, control proceeds to the rental processing subroutine (step n113). If the return key is depressed, control proceeds to the return processing subroutine (step n114).

Fig. 16b shows the rental subroutine. When a

card is inserted (in step n120), control determines whether this card is valid or not (in step n121). If valid, control authenticates this card in communication with a credit center (in step n122). If authentication is OK (in step n123), a videocassette is selected (in step n124), and this videocassette is retrieved from the videocassette data file (in step n125). When control determines that the selected cassette is still accommodated without being rented (in step n126), control proceeds to step n127. If already rented, control returns to step n124 to stand by the another selection.

Control records the rental data in the rental file (in step n127), returns the card (in step n128) and discharges the videocassette (in step n129). Further, if the card is invalid (in step n121) or not authenticated (in step n123), the card is returned to the customer (in step n130).

Fig. 16c shows the return subroutine. When control proceeds to this operation, a videocassette to be returned is first inserted (in step n140). Control reads a bar code formed on the surface of the inserted videocassette (in step n141). Control determines whether a bar code is read normally (in step n142). If read normally, the rental file is retrieved on the basis of the read bar code (in step n143), and the videocassette is restored to a corresponding slot 50a (in step n144). Thereafter, control updates the videocassette data file by recording that the cassette is returned and deletes the corresponding data in the rental file (in step n145), and calculates the rental fee (in step n146) and displays the calculated fee (in step n147). After fee has been paid (in step n148), a receipt is printed and discharged (in step n147), returning to the original step.

On the other hand, if a bar code is not read normally (in step n142), control displays "Code is unreadable" and "Insert card" (in step n150), and reads the inserted card data (in step n151). The rental file is retrieved on the basis of the card data (in step n152) and a list representative of all the videocassettes rented by this customer is displayed on the CRT (in step n153). When the customer selects a videocassette to be returned from among the displayed videocassettes through the cassette selection key 10 (in step n154), the rental file is updated on the basis of these data (in step n155). After the videocassette is accommodated in the defective cassette accommodating slot 50b (in step n156), control proceeds to the fee settlement operation of step n146 and after. The videocassettes once returned to the defective cassette accommodating slot 50b are not rented without repairing the bar code.

Further, in this embodiment, the rental fee can be paid by cash, a credit card, a prepaid card, etc.

## Claims

1. An automatic article renting machine (1) comprising:

article accommodating means (50) having a plurality of compartments (50a) in which articles are held, each article having an identification code (11);

an article rental/return slot (9);

article conveying means (35, 51) for moving an article between each compartment and the article rental/return slot;

rental processing means (20, 21) for causing the conveying means to convey a designated article from the compartment to the rental/return slot; and

return processing means (20, 21) for causing the conveying means to convey a returned article from the rental/return slot to a compartment in which the returned article is to be held.

2. An automatic article renting machine as defined in claim 1 further comprising:

means (30) for inputting an identification data of a customer;

file means for storing the number of articles being rented for each customer identification data;

means, whenever an article is rented by a customer, for determining the number of articles being rented for the customer identification data of the customer on the basis of the data stored in the file means; and

means for prohibiting the rental processing by the rental processing means when the number of articles being rented exceeds a predetermined number.

3. An automatic article renting machine as defined in claim 1 or 2 further comprising:

a management table for recording at least one of rental fee and rental period for each identification code of the article to be rented;

means for settling rental fee being paid by at least one of cash or card on the basis of the data in the management table;

at least one of a rental fee table in which rental fees are adjusted according to days of the week and a rental period table in which rental periods are determined for each day of the week;

a calendar clock (29) for counting days of the week; and

means for determining at least one of a today's rental fee or a today's rental period in the management table with reference to a day of the week indicated by the calendar clock and at least one of the rental fee table and rental period table.

4. An automatic article renting machine as defined in claim 3 further comprising:

operation mode selecting means for selecting any one of the rental fee table and rental period

table, and

wherein the determining means determines a today's rental fee or a today's rental period in the management table with reference to the day of the week indicated by the calendar clock and the table selected by the operation mode selecting means. 5

5. An automatic article renting machine as defined in claim 1, 2 or 3 further comprising:

first means (34) for reading the identification code on the article; 10

second means (30) for reading an identification data recorded on a card of a customer;

the rental processing means for storing a customer identification data read from the card and a identification code read from an article to be rented or a code related to the article to be rented in corresponding relation to each other as rental data; 15

the return processing means for performing a return processing on the basis of the rental data corresponding to the identification code read from the returned article; 20

means for allowing the customer card to be inserted into the second means, when an identification code on a returned article is not readable by the first means; 25

means for allowing a data for identifying the returned article to be inputted;

the return processing means for performing an article return processing on the basis of a rental data specified by the customer identification data read by the second means and the inputted article identifying data; and 30

means for inhibiting an article whose identification code is not readable from being rented again by the rental processing means. 35

40

45

50

55

11

Fig.1

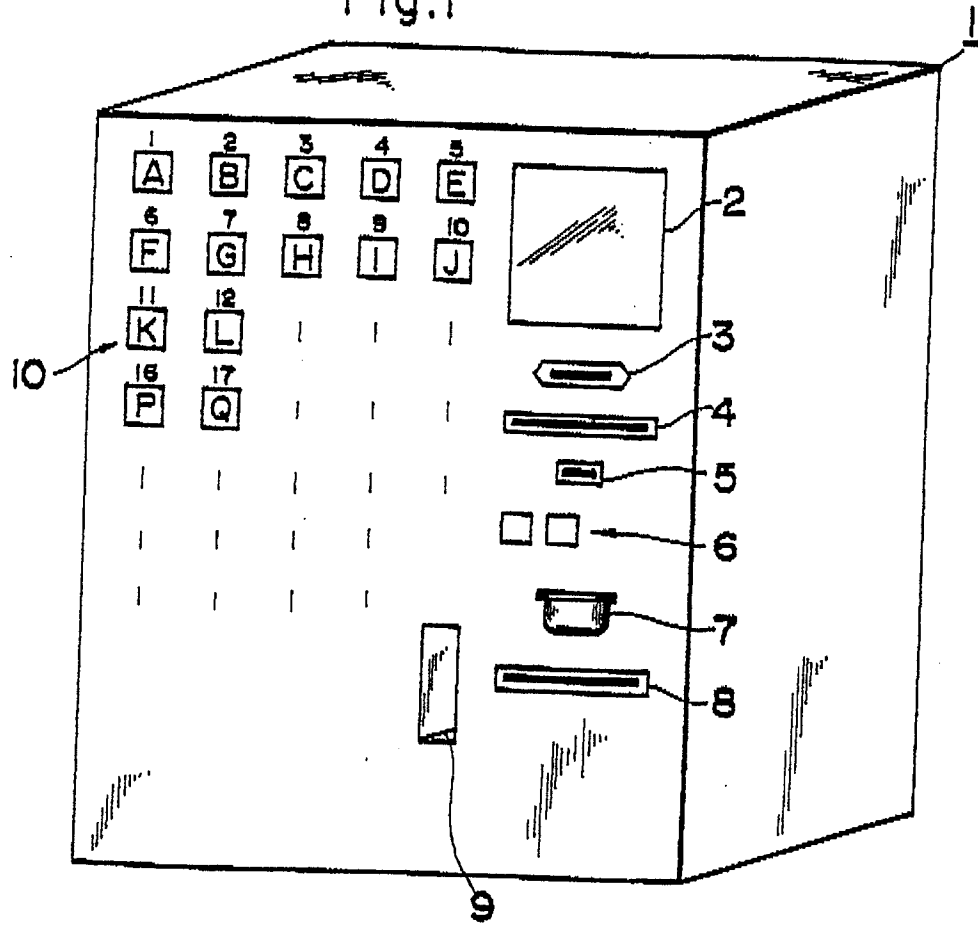

Fig.2

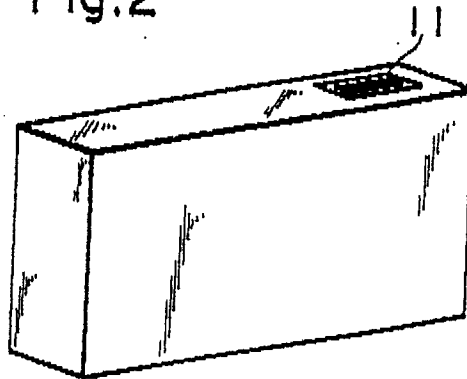

Fig.3

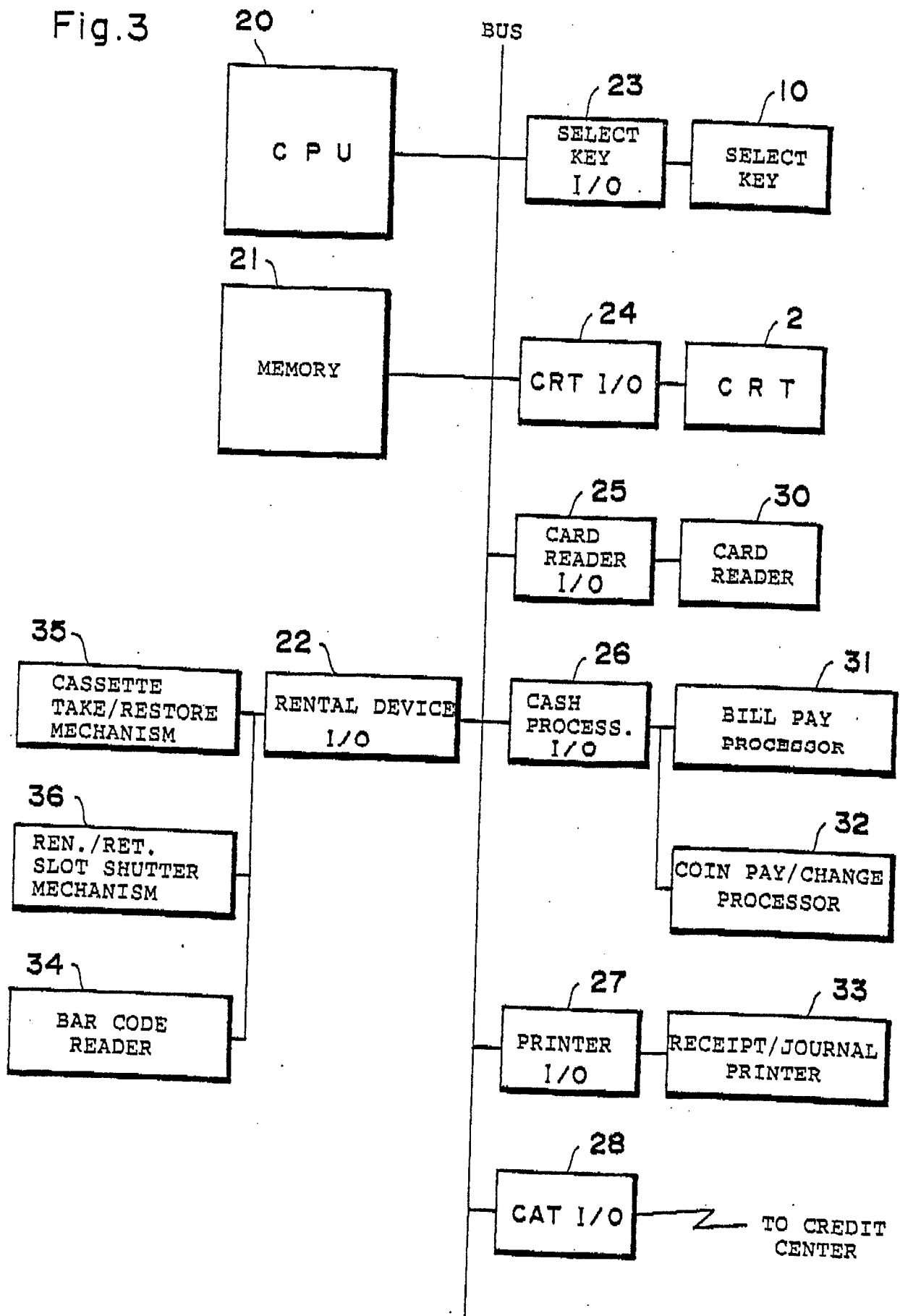

Fig.4

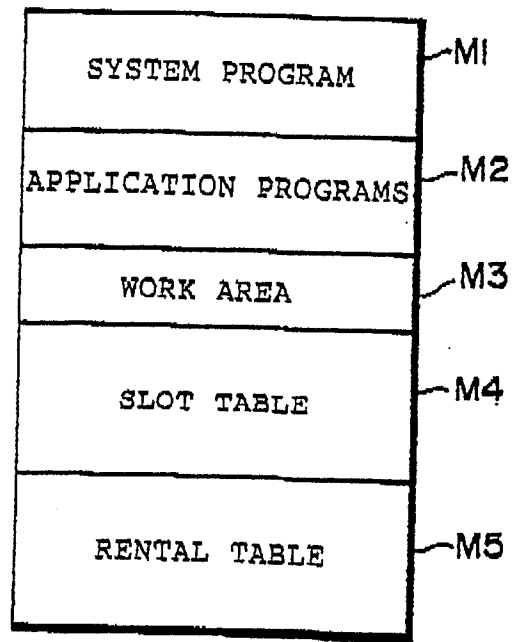

Fig.5

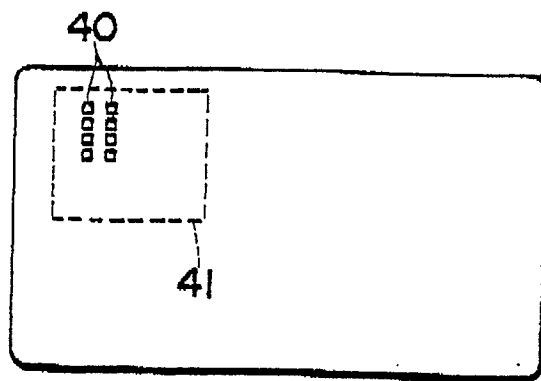

Fig. 6

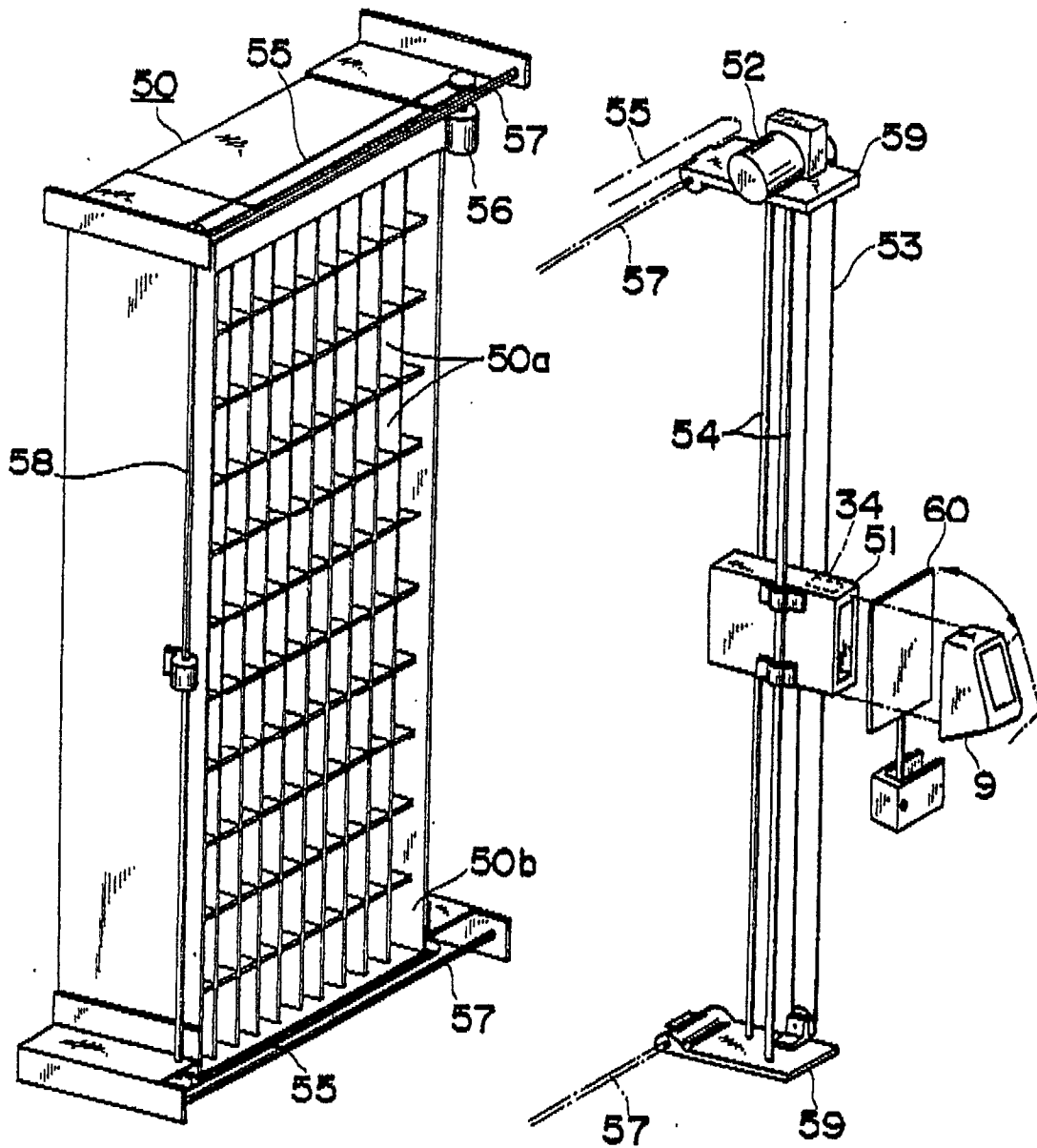

Fig.7a

## IC MEMORY MAP

KEY NO.	TITLE	CASSETTE NO.	SLOT NO.	FEE	CHANGE FLAG
1	A	1002	001	700	1
2	B	1010	005	700	1
3	C	1016	008	500	0
4	D	2010	100	400	0
5	E	2030	002	800	0
6	F	2040	007	1000	0
7	G	3050	050	300	0
8	H	3051	058	700	0
100	A D	6001	040	800	0

Fig.7b

SLOT TABLE

KEY NO.	TITLE	CASSETTE NO.	SLOT NO.	FEE	RENTAL FLAG	UNRENTAL FLAG
1	A	1001	001	700	1	0
2	B	1010	005	600	0	0
100	AD	6001	040	800	0	0

Fig.7c

RENTAL TABLE

CASSETTE NO.	RENTAL DATE	ID NO.	FEE
1001	870109	123456	700
2040	870110	765432	600
1015	870131	876543	500

Fig.8a

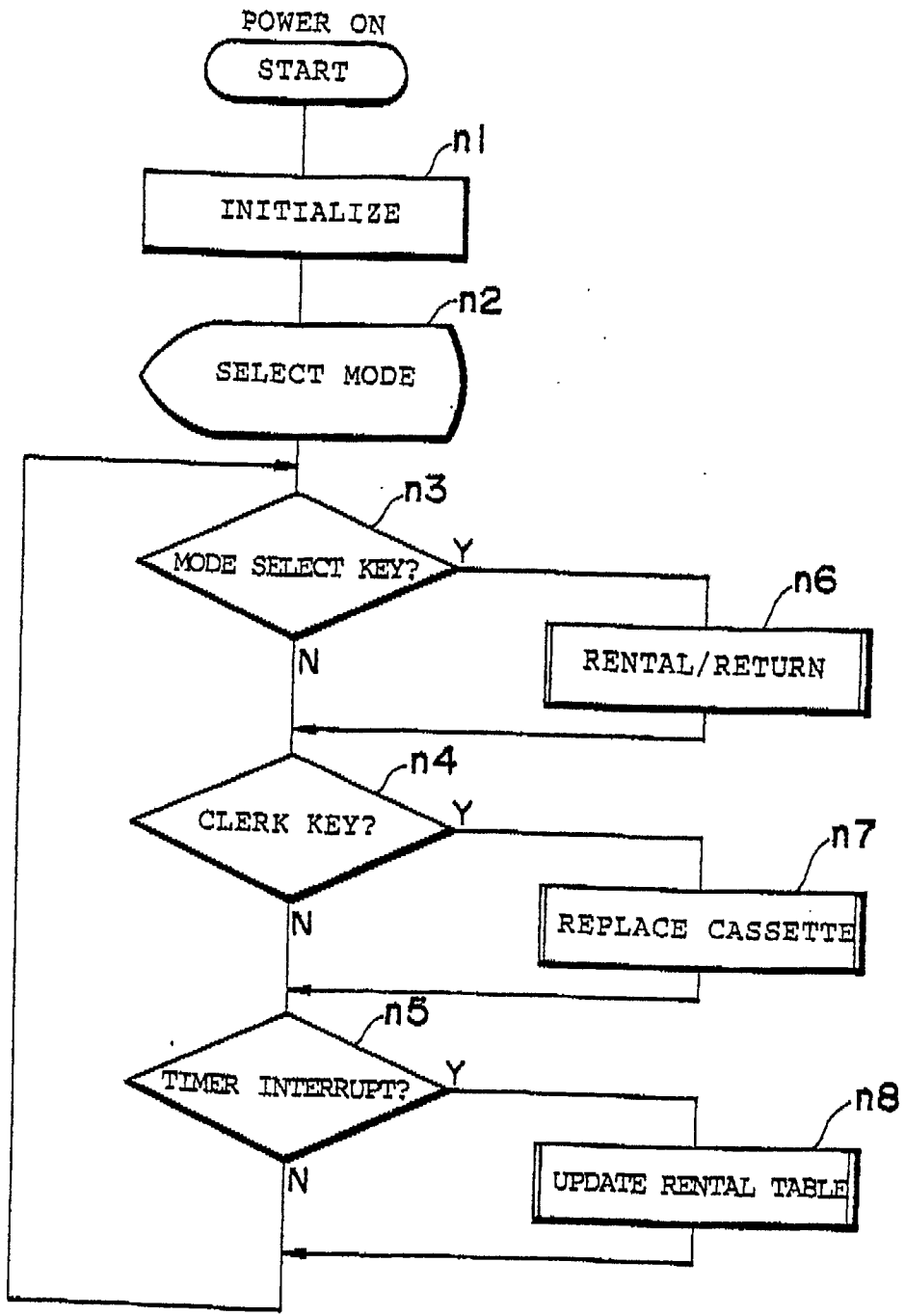

Fig.8b

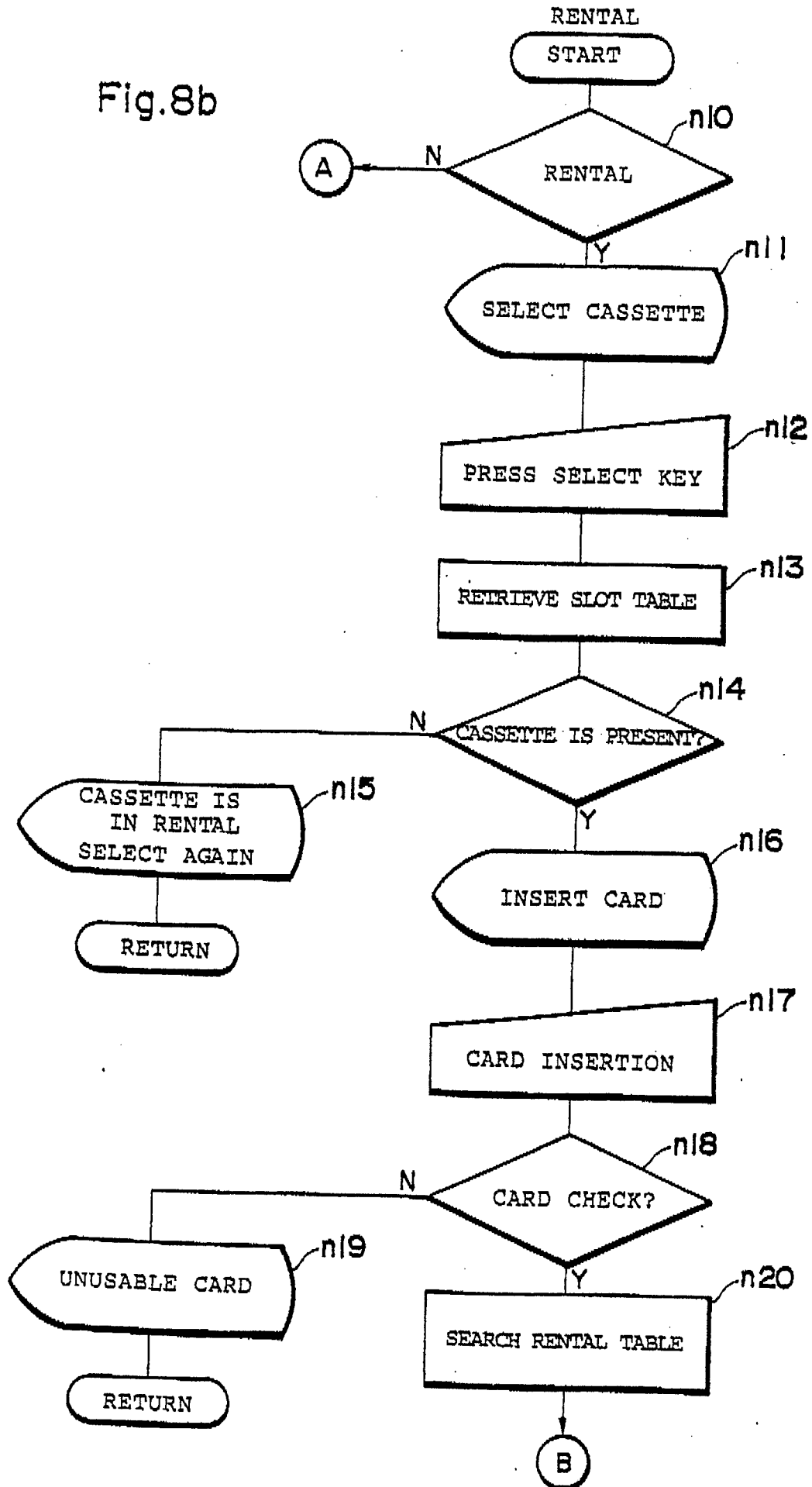

Fig.8d

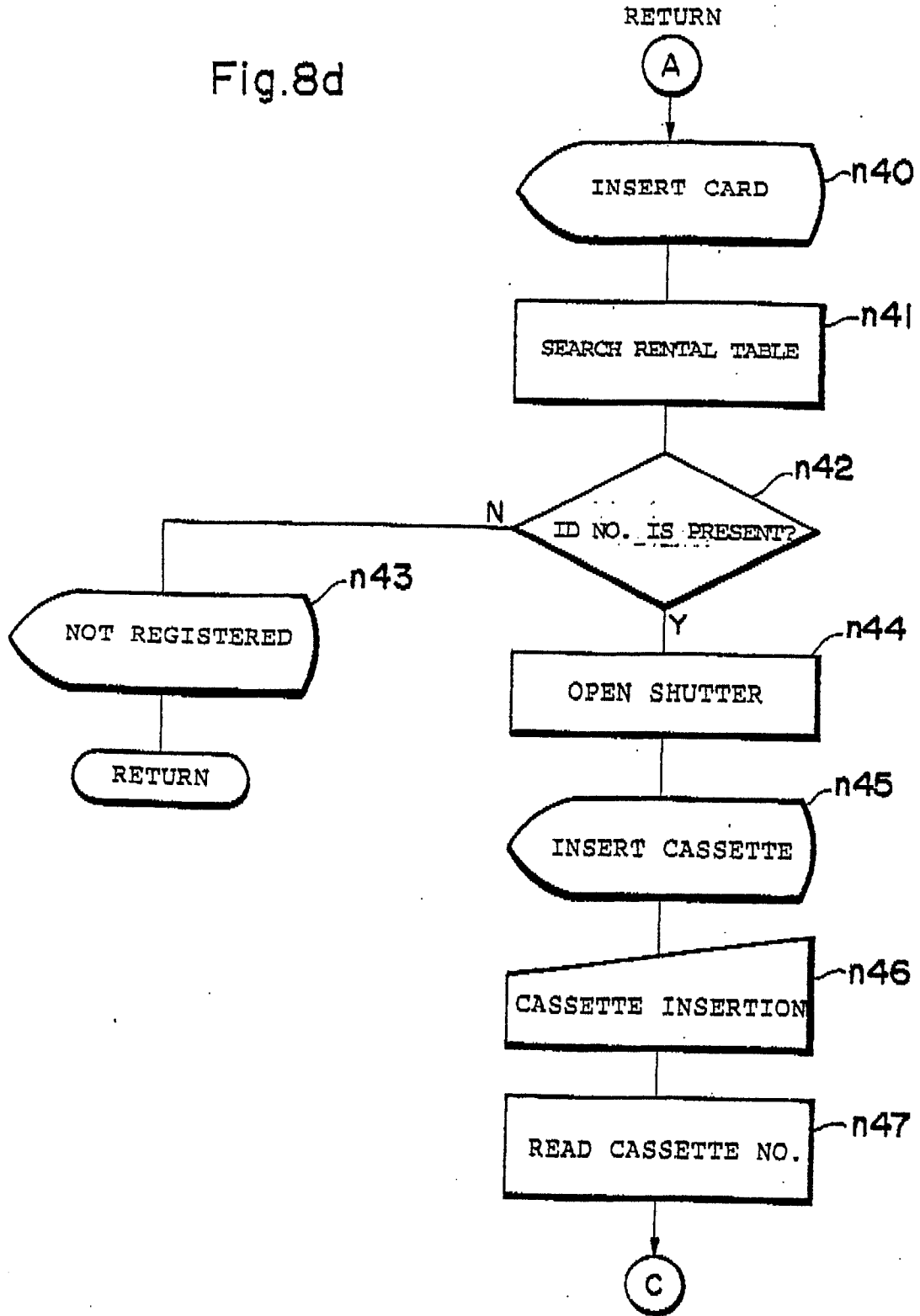

Fig. 8e

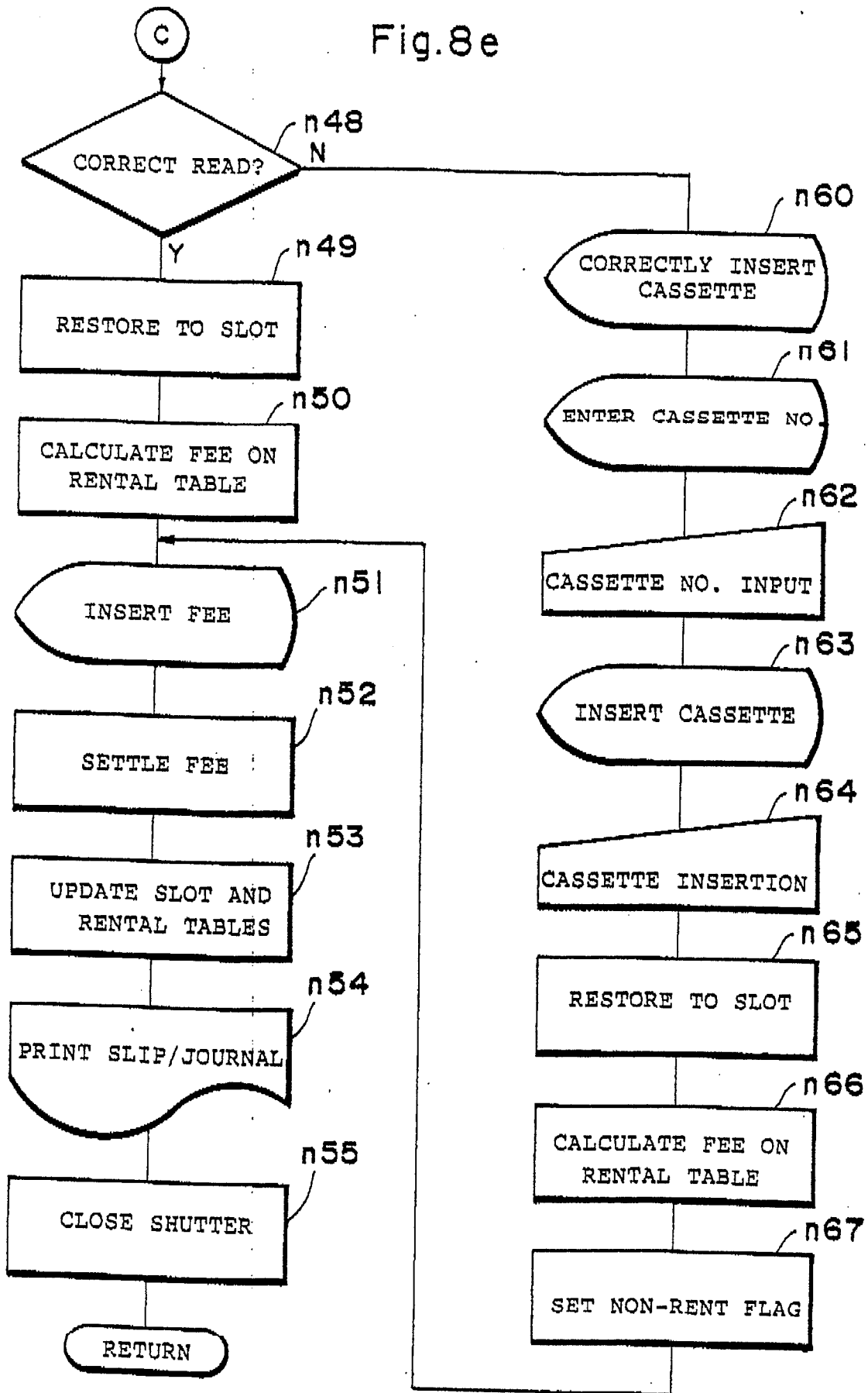

Fig.8f

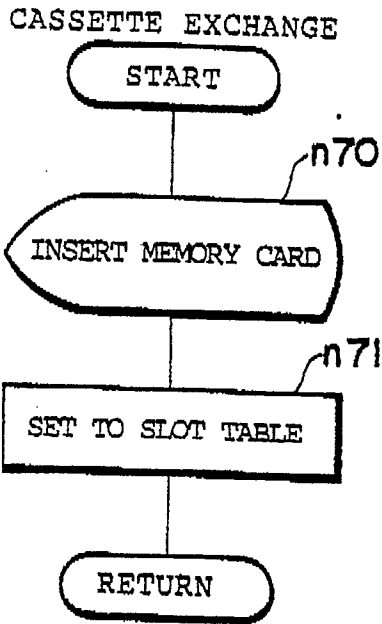

Fig.8g

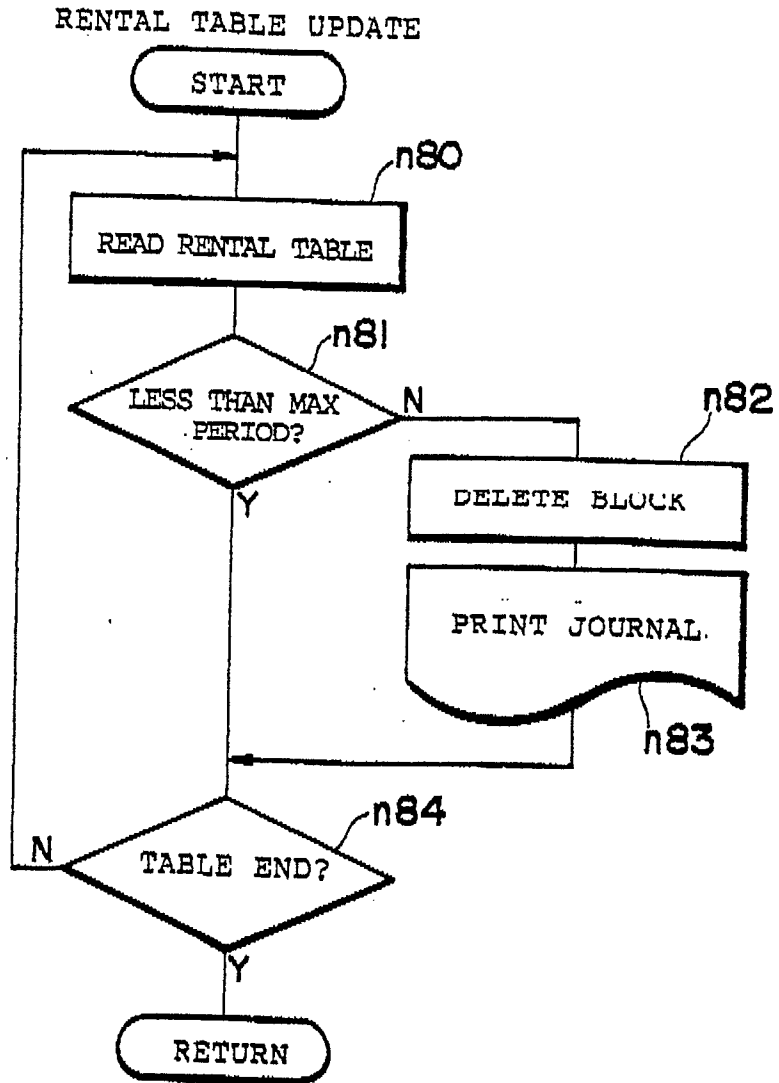

Fig.9

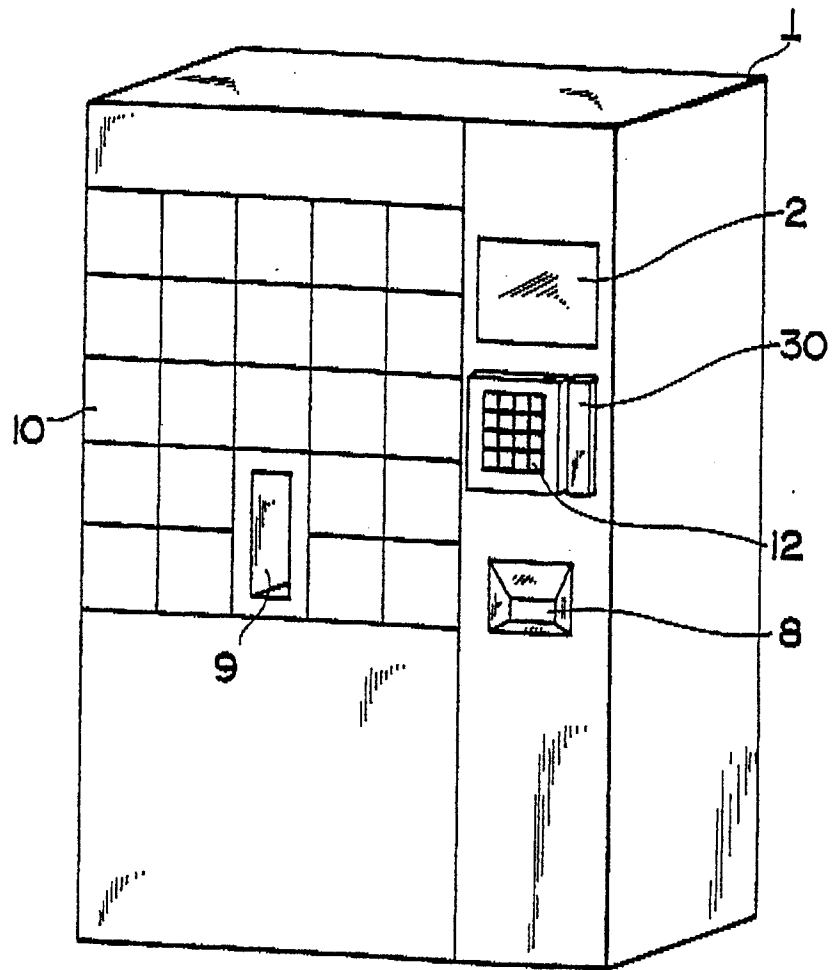

Fig.10

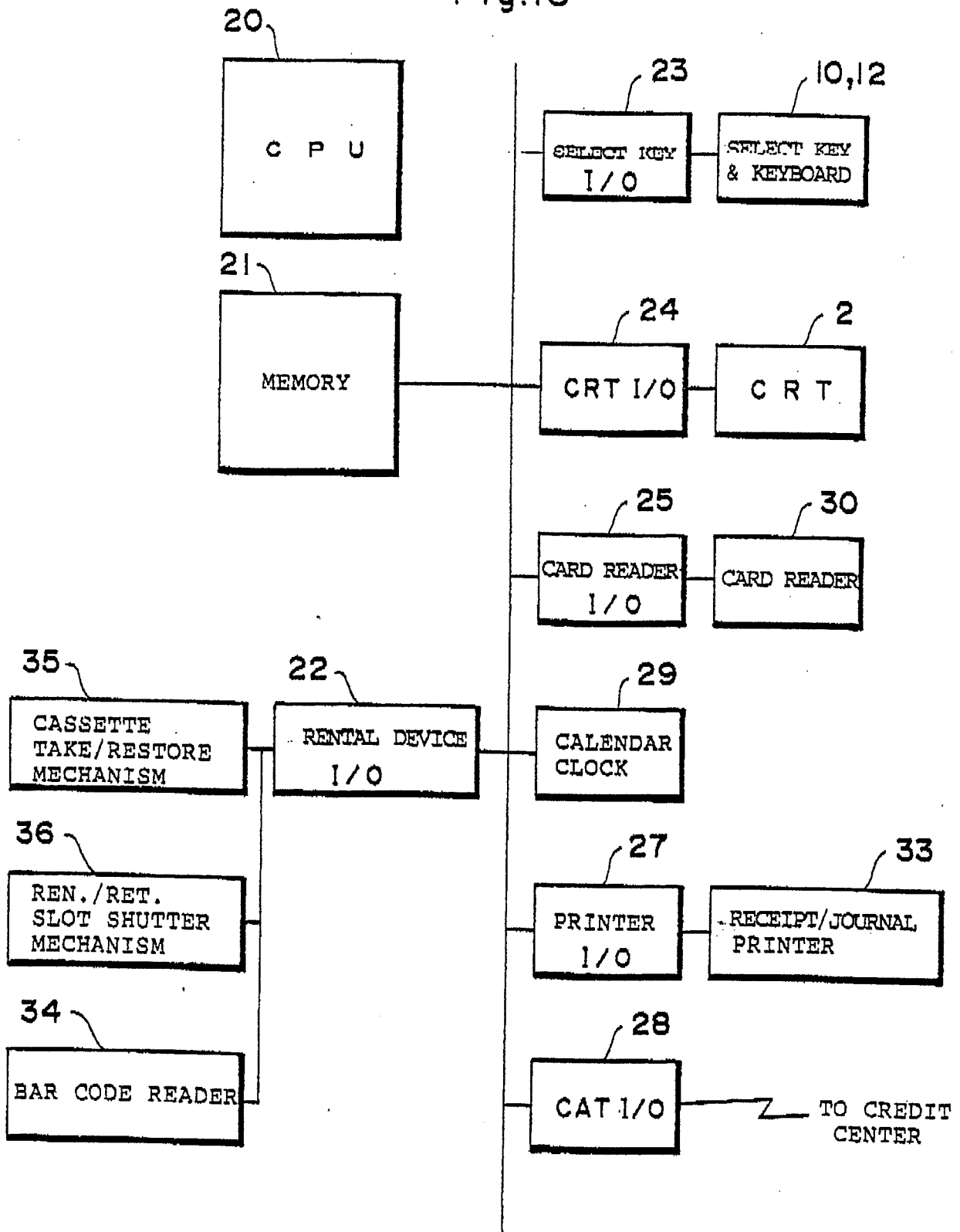

Fig. 11

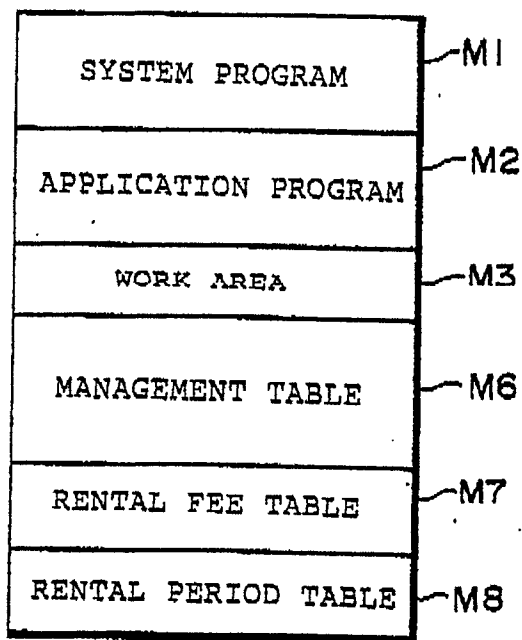

Fig.12

MANAGEMENT TABLE

NO.	TITLE	CASSETTE NO.	SLOT NO.	FEE	PERIOD	RENTAL DATE	RENTAL FLAG
1	A	1001	001	300	2	870109	1
2	B	1010	005	500	2	870108	1
3	C	1020	010				0

Fig.13a

RENTAL FEE TABLE

DAY	FEE(YEN)
MON.	300
TUE.	300
WED.	300
THU.	300
FRI.	400
SAT.	500
SUN.	300

Fig.13b

RENTAL PERIOD TABLE

DAY	PERIOD
MON.	3
TUE.	3
WED.	2
THU.	2
FRI.	1
SAT.	1
SUN.	3

Fig. 14a

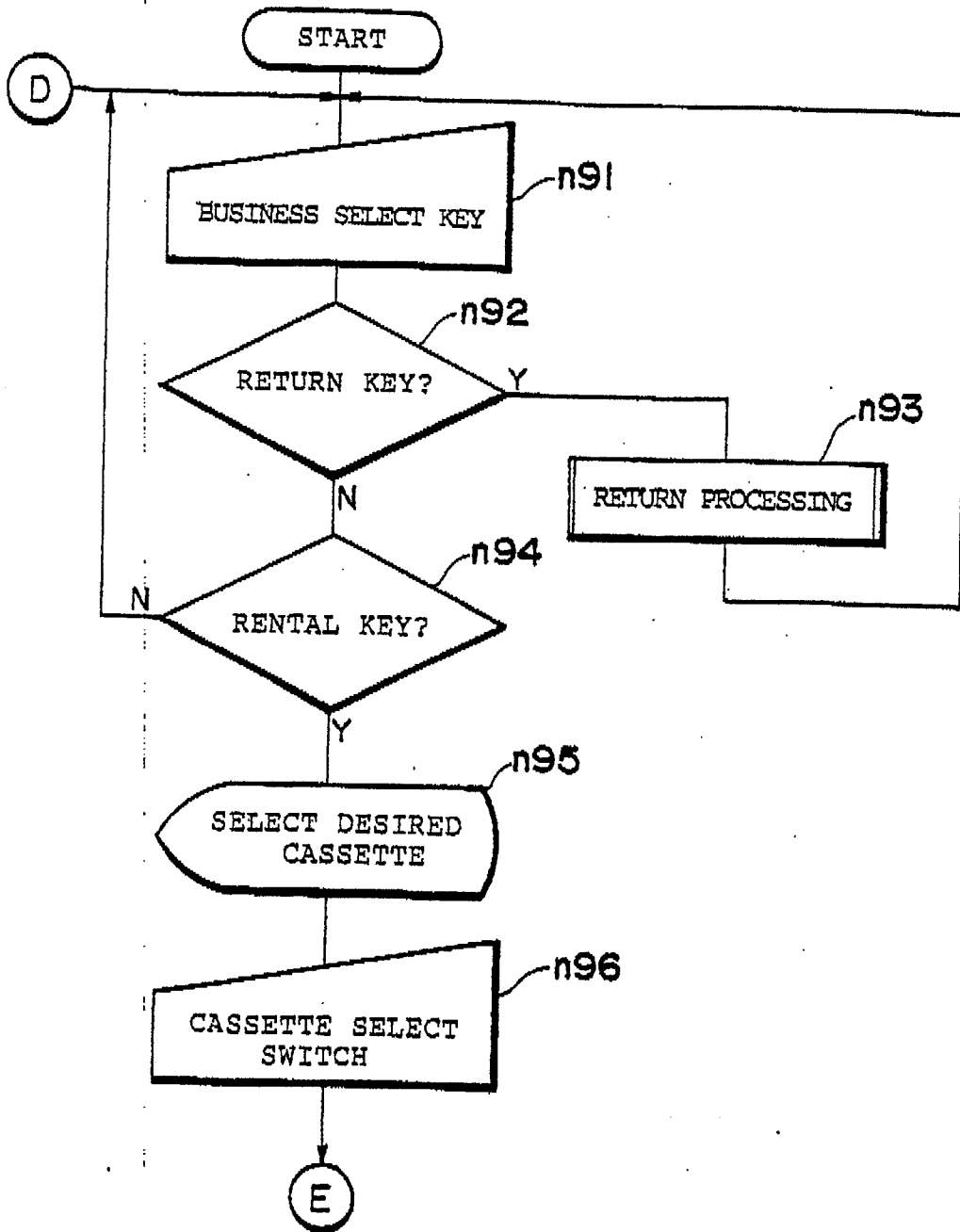

Fig. 14b

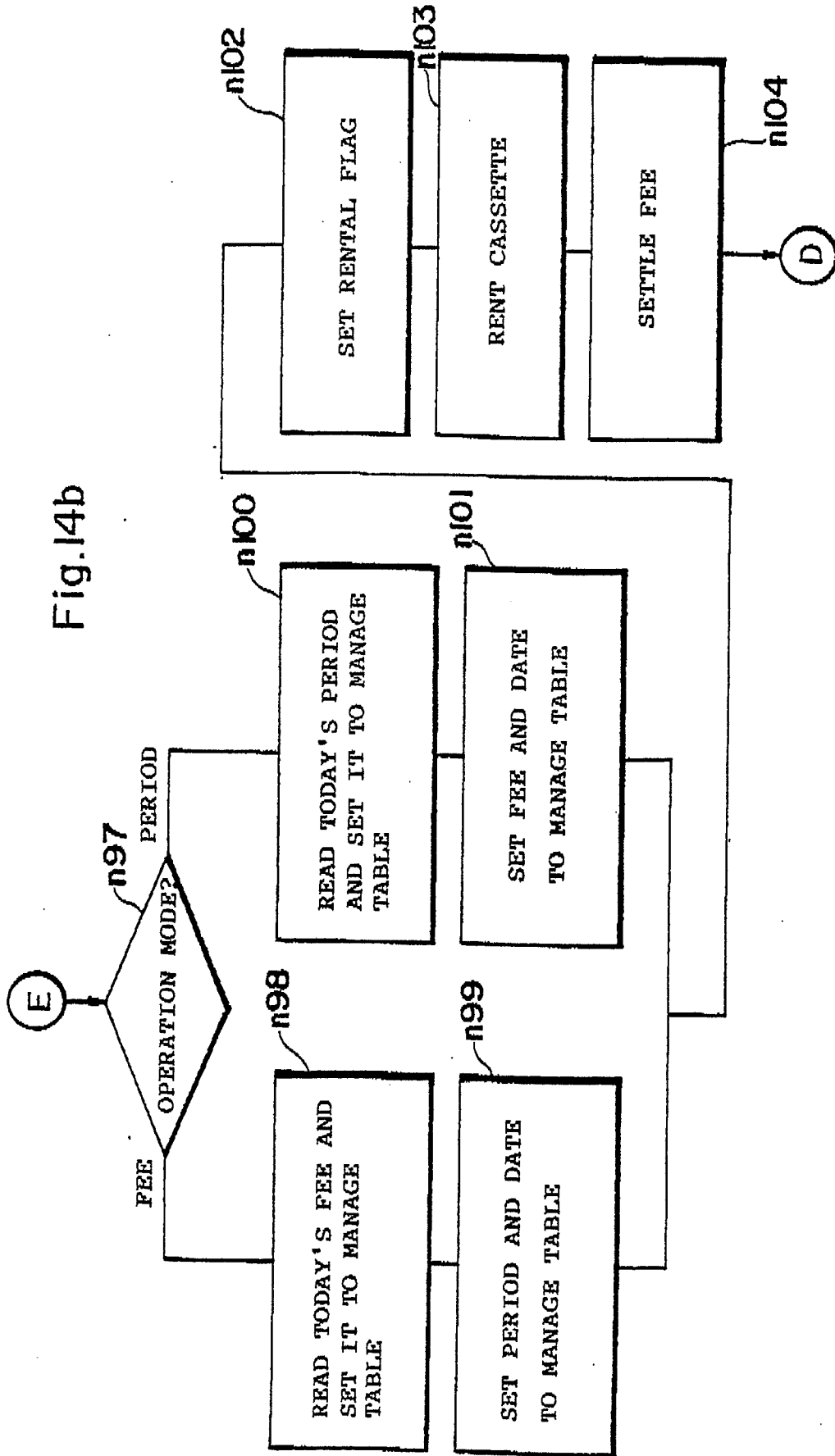

Fig. 15a

CASSETTE DATA FILE

CASSETTE NO.	TITLE	RENTAL FLAG	SLOT NO.	CUSTOMER ID CODE	RENTAL FEE

Fig. 15b

RENTAL FILE

RENTAL DATE	RETURN DATE	CUSTOMER ID CODE	SECRET NO.	CASSETTE NO.	TITLE

Fig.16a

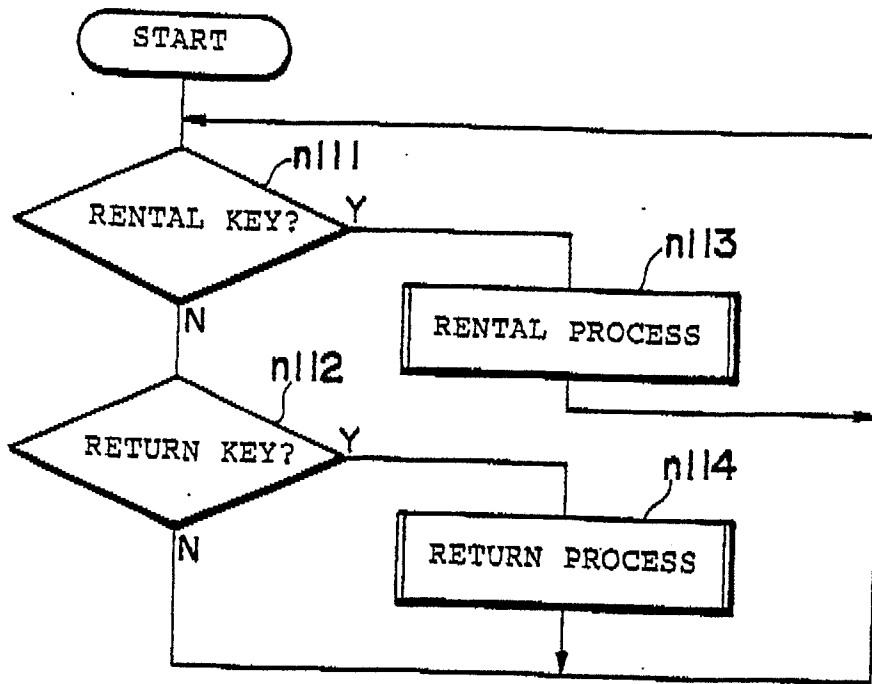

Fig.16b

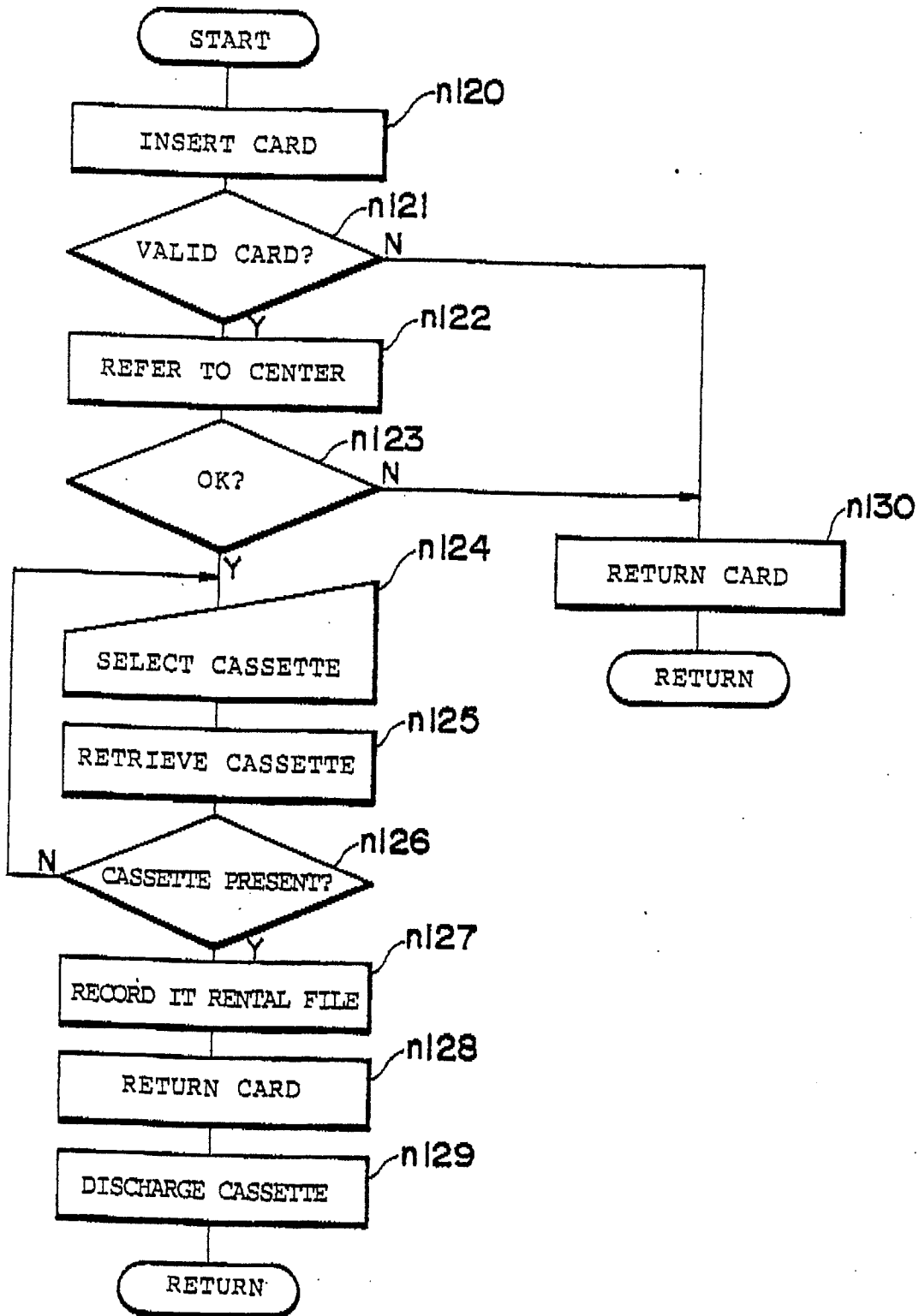

Fig.16c

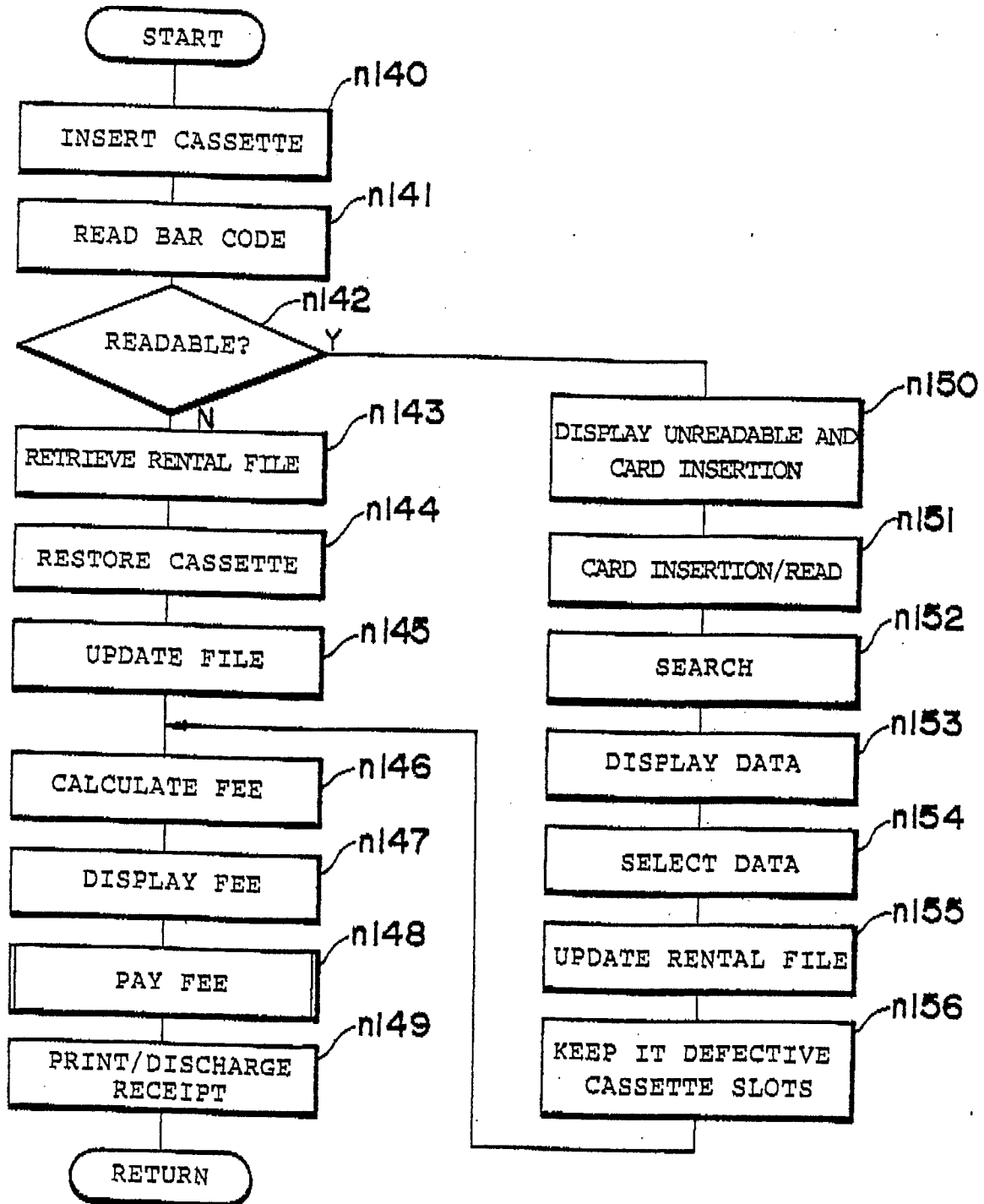

Fig.8c

