

(No Model.)

2 Sheets—Sheet 2.

H. A. & C. S. ARNOLD.
HORSE DRIVER AND GOVERNOR.

No. 522,956.

Patented July 17, 1894.

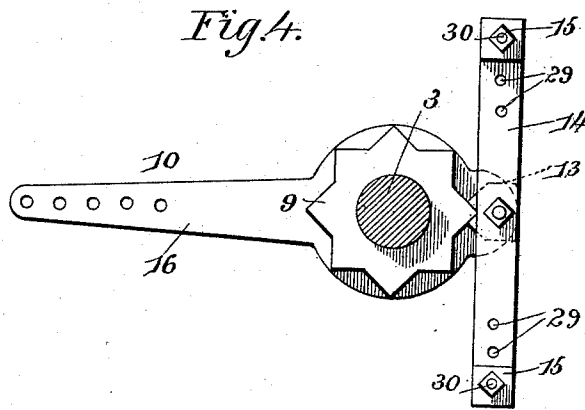
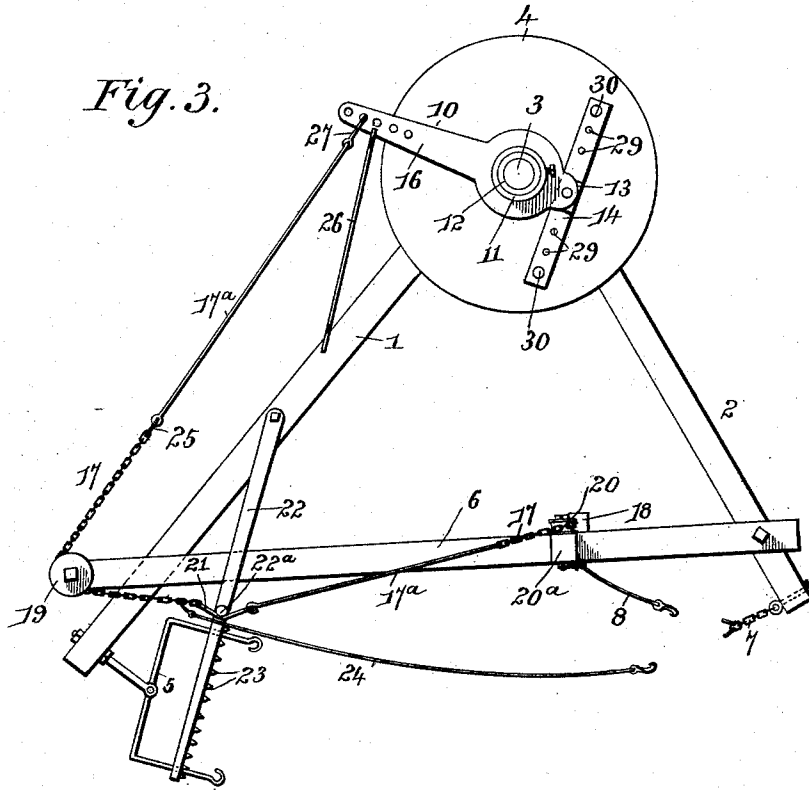

Witnesses
Jas. H. McArthur
[Signature]

Inventors
Henry A. Arnold
Clifton S. Arnold
by *[Signature]* Attorneys

UNITED STATES PATENT OFFICE.

HENRY A. ARNOLD AND CLIFTON S. ARNOLD, OF GENEVA, WISCONSIN.

HORSE DRIVER AND GOVERNOR.

SPECIFICATION forming part of Letters Patent No. 522,956, dated July 17, 1894.

Application filed October 26, 1893. Serial No. 489,188. (No model.)

To all whom it may concern:

Be it known that we, HENRY A. ARNOLD and CLIFTON S. ARNOLD, citizens of the United States, residing at Geneva, (Lake,) in the county of Walworth and State of Wisconsin, have invented a new and useful Horse Driver and Governor, of which the following is a specification.

Our invention relates to a horse driver and governor for use in connection with rotatable sweeps of the ordinary horse-powers or other power-transmitting mechanisms, the same being adapted to be employed with powers employing any number of horses.

The objects of our invention are to provide automatic means for controlling or regulating the speed of the horse or horses while operating the power in order to produce a steady motion of the machine or machines to which the power is attached, although the resistance of the machinery may vary from time to time; and furthermore, to provide means for encouraging the tardy without fretting the nervous horses by the use of a whip.

Further objects and advantages of this invention will appear in the following description, and the novel features thereof will be particularly pointed out in the appended claims.

In the drawings: Figure 1 is a perspective view showing a construction embodying a single draftsweep and accompanying lead sweep in connection with an ordinary horse-power and provided with a driving and governing mechanism embodying our invention, only those parts of the power which are necessary to an understanding of the operation of our invention being illustrated. Fig. 2 is a sectional view of the escapement device which is used in connection with our driving and governing mechanism. Fig. 3 is a plan view of the driving and governing mechanism attached as in Fig. 1 to a sweep power. Fig. 4 is a detail plan view of the escapement device.

Similar numerals of reference indicate corresponding parts in all the figures of the drawings.

1 represents a draft-sweep, and 2 a lead-sweep of a horse-power of the ordinary construction, and 3 represents a pivot-post which rises vertically from the center of a horizontal stationary platform 4, beneath which is

arranged the gearing and operating connections indicated at 4^a, for the transmission of power to the shaft 4^b, whereby it is communicated to the machinery to be driven.

The post or platform, or both, may be fitted to an ordinary sweep horse-power now in general use, together with the parts hereinafter described which are carried thereby.

To the outer end of the draft-sweep is connected a whiffletree 5, to which the horse or horses are attached, and a guide-bar 6 connects the draft and the lead sweeps and lies parallel with the line of draft, the horse being held parallel with the said bar by means of a lead-chain 7, which is carried by the extremity of the lead-sweep, and an inside line 8, which will be hereinafter more fully described.

We also employ an escapement device having an escapement-wheel 9, which is secured rigidly to the pivot-post 3, a short distance above the transmitting mechanism, and a spider 10 is loosely mounted upon the pivot-post above and rests upon the upper side of said escapement-wheel, the spider being held from displacement by a collar 11, which is formed at the upper end of a sleeve 12 joined to the escapement-wheel.

The spider carries a pivoted escapement pawl 13, which engages the escapement-wheel whereby as the spider is revolved around the pivot-post the escapement pawl rocks or vibrates by its contact with the escapement-wheel. The escapement pawl preferably spans only one tooth of the escapement-wheel at a time, which gives the pawl a much longer swing than could be attained if it were caused to span more than one tooth. A weighted lever 14 is attached at its center to the escapement pawl and is carried thereby so that as the pawl is vibrated by its contact with the escapement-wheel, said lever is similarly operated. The ends of the lever are provided with equal weights 15, whereby the lever is balanced and will be caused to start automatically when pressure is applied laterally to the longer arm 16 of the spider.

The longer arm of the spider is connected, by means of a chain 17, to a propelling-weight 18, and extends over or around the idle guide-pulleys 19 and 20, which are located, respectively, near the extremity of the guide-bar

adjacent to the draft-sweep, and at an intermediate point of said guide-bar adjacent to the lead-sweep. The tendency of the propelling-weight 18 is to draw the free end of the longer arm 16 of the spider outward, or in the direction of the chain 17. The intermediate portions of this chain may be substituted by wire, as shown at 17^a.

At an intermediate point of the chain 17, between the guide-pulleys 19 and 20, is arranged a hook or clip 21, and a driving-bar 22, which is pivoted at its inner end, or otherwise loosely connected, to the draft-sweep, is provided with a pin 22^a, engaged by said hook or clip 21, whereby the movements of the chain are communicated to the driving-bar. The angular shape or disposition of the chain maintains the hook or clip in engagement with the pin. The driving-bar extends beyond the connection of the chain above the plane of and adjacent to the whiffletree, and is provided with a series of short barbs or tacks 23, which are arranged upon the front surface of the bar in position to prick the horse or horses when brought in contact therewith.

The inside line or head-strap 8 is attached to the guide-bar, and the outside or driving line 24 is carried rearwardly behind the horse and is fastened to the driving-chain 17 near the rear guide-pulley.

When more than one team is employed, additional sweeps, equalizers, and guide-bars must be employed, the driving-chain being extended forward through additional guide-pulleys, and the weight attached ahead of the foremost team. The lines and driving-bars are attached to the sweeps and driving-chains as described for the first team.

26 represents a brace-bar, which is employed to hold the operating-arm 16 against the draft of the propelling weight 18, while the machine is not in use.

Having now described the construction of our improved horse driver and governor, the operation is as follows: The horse or horses being attached to the whiffletree in the manner and position described, and being disposed substantially parallel with the guide-bar, or so that the draft upon the sweep shall be parallel with said bar, the brace 26 which is only employed when the machine is not in use is withdrawn to allow the operating-arm 16 to be drawn forward by the weight 18, thus causing the driving-bar 22 to swing against the horses. If the latter start immediately, the forward motion which is imparted to the sweep and the resistance which is offered to the spider by the operation of the escapement device will retard the movement of the escapement-chain relatively to the sweep and remove the driving-bar from contact with the horses. During the operation of the machine the free end of the driving-bar is held out of contact with the team by means of the escapement device, the distance at which said bar is held varying slightly

according to the rate of movement. When the horse is moving at the desired rate of speed, which is predetermined, and the hook 27, which is attached to the inner end of the chain 17, is engaged in the desired perforation 28 of the operating-arm 16, and the driving-bar is adjusted to engage its pin with the hook or clip 21, the driving-bar will be held in a retracted position as long as an approximately steady movement is maintained; but if the speed is increased beyond a certain limit the driving-line 24 will be retarded by means of the chain 17, owing to the constant resistance of the escapement device thus partially checking the horse; and if the speed is diminished beyond a certain limit, the propelling-weight 18 which opposes the resistance offered by the escapement device will draw the chain relatively forward and cause the driving-bar to come in contact with the horse, thus urging him forward. The driving-bar is provided, as above described with barbs or spurs, and these parts are arranged in the driving-bar in such a manner that they may be adjusted to cause them to protrude more or less, as may be found necessary.

From the above description it will be seen that inasmuch as the escapement wheel is fixed, and the only connection between the sweep and the arm of the spider is through the flexible chain, the forward movement of the sweep will not be communicated positively to the spider, and hence the resistance offered to the escapement pawl by the fixed escapement wheel will tend to retard the motion of the arm of the spider or will tend to cause a slower rotation of the spider. This resistance of the escapement device is opposed by the weight 18, and therefore whenever the speed of the sweep is reduced below that which can be caused in the spider by the weight, the spider will advance more rapidly than the sweep and thus bring the driving bar in contact with the horses. Furthermore it will be understood that the speed of operation may be varied by the adjustment of the hook 27 in the perforations of the arm 16; but adjustment may be attained also by the arrangement of the weights upon the escapement-bar 14. Thus, to increase the speed of the team, the weights 15 are adjusted nearer the center of the bar thus reducing the resistance offered by the escapement device; and to diminish the speed, the weights are arranged near the extremities of the same, thus increasing the resistance of the escapement device the bar being provided for this purpose with a series of perforations 29 to receive bolts 30. In other words, the adjustment of the weights 15 nearer the center of the bar 14 reduces the leverage of said bar, and the connection of the chain near the outer extremity of the arm 16 increases the effect of the weight 18 by lengthening the leverage of said arm, thereby giving said weight, in either case, an increased influence upon the escapement device and requiring an increased speed of the sweep to

keep it in advance of the driving bar and hold the latter in a retracted position. The outward adjustment of the weights 15, or the connection of the chain to the arm 16 at a point nearer the fulcrum of the latter, decreases the effect of the weight 18 and increases the resistance of the escapement pawl, and therefore maintains the driving bar in its retracted position with a less rapid movement of the sweep.

Various changes in the form, proportion, and the minor details of construction may be resorted to without departing from the principle or sacrificing any of the advantages of this invention.

Having described our invention, what we claim is—

1. In a device of the class described, the combination with a rotatable sweep, of a driving-bar carried by the sweep, an escapement device, means for normally holding said driving-bar in its operative position, and flexible connections between the escapement device and the driving bar whereby the latter may be held in a retracted position by the resistance of the escapement device, substantially as specified.

2. In a device of the class described, the combination with a rotatable sweep, of a pivotal driving-bar carried by the sweep, an escapement device, a flexible connection between the escapement device and the driving-bar, and means for automatically advancing said flexible connection in opposition to the resistance of the escapement device to hold the driving-bar in its operative position, substantially as specified.

3. In a device of the class described, the combination with a rotatable sweep, of a driving-bar carried thereby, an escapement device, a chain connecting said driving-bar to the escapement device, a driving or restraining line connected to the chain, and means for advancing the chain in opposition to the resistance of the escapement device to hold the driving-bar in its operative position, substantially as specified.

4. In a device of the class described, the combination with a rotatable sweep, of an escapement device comprising a spider provided with an operating arm 16, an escapement-wheel, and a pivotal escapement pawl carried by said spider to engage the projections of the escapement-wheel, a pivotal driving-bar, a flexible connection attached at one end to the said operating arm 16, extending over suitable guide-pulleys and provided with an operating weight to oppose the resistance of the escapement device, the driving-bar being connected to the said flexible connection, and a driving or restraining line attached to said flexible connection, substantially as specified.

5. In a device of the class described, the combination with a rotatable sweep, of a rotatable spider mounted upon the pivotal post of said sweep, escapement devices connecting the spider and the pivotal post, a chain adjust-

ably connected at one end to the arm of said spider and provided at the opposite end with a counter-balancing weight, and a driving-bar pivotally connected to said sweep and connected at an intermediate point to the said chain, substantially as specified.

6. In a device of the class described, the combination with a rotatable sweep, of a pivotal driving bar, an escapement device, a chain connected at one end to said escapement device and provided at the opposite end with a propelling device, and means to connect the driving-bar to the said chain, substantially as specified.

7. In a device of the class described, the combination with a rotatable sweep, of an escapement device comprising a fixed escapement-wheel, a rotatable spider, an escapement pawl pivotally connected to said spider, a balancing-bar fixed at its center to said escapement pawl, a chain connected at one end to said spider and provided at its opposite end with a counter-balancing weight, and a driving-bar pivotally connected to the sweep and attached at an intermediate point to the said chain, substantially as specified.

8. In a device of the class described, the combination with a rotatable sweep, of an escapement device comprising a fixed escapement-wheel, a rotatable spider, and an escapement pawl pivotally connected to said spider, a balancing-bar fixed at its center to said escapement, weights adjustably attached to the arms of said balancing-bar, a chain connected at one end to said spider and provided at its opposite end with a counter-balancing weight, and a pivotal driving-bar connected to an intermediate point of said chain, substantially as specified.

9. In a device of the class described, the combination with a draft-sweep and a lead-sweep, of a connecting guide-bar, an escapement device, a chain connected at one end to said escapement device, passing over pulleys carried by said guide-bar and provided with a counter-balancing weight, and a driving-bar pivoted at one end to the draft-sweep and connected to an intermediate point of the said chain, substantially as specified.

10. In a device of the class described, the combination with a sweep, of a pivotal operating-arm 16, an escapement device connected to and resisting the rotary movement of said operating-arm, a weighted chain connected to the operating-arm to oppose the resistance of the escapement device, a hook or clip connected to the said chain at an intermediate point, and a driving-bar pivotally connected to the sweep and engaged in said hook or clip, substantially as specified.

11. In a device of the class described, the combination with a pivot-post, and a sweep mounted thereon, of an escapement device having a fixed escapement-wheel carried by said pivot-post, a spider rotatably mounted upon the pivot-post, and a vibratory escapement pawl carried by the spider and engaged

ing the teeth of the escapement-wheel, a driving-bar pivotally connected to the sweep, and connections between the spider and the driving-bar, substantially as specified.

5 12. In a device of the class described, the combination with a rotatable sweep, of a movable driving bar arranged adjacent to the sweep, a driving or restraining line, and means for actuating said bar and line, said
10 means consisting of an escapement device and a weighted flexible connection between said escapement device and the bar and line, whereby the movement of said bar and line is retarded during the forward movement of

the sweep by the resistance offered by the es- 15
capement device and are allowed to advance when the movement of the sweep ceases, or the speed of movement diminishes, substantially as specified.

In testimony that we claim the foregoing as 20
our own we have hereto affixed our signatures in the presence of two witnesses.

HENRY A. ARNOLD.
CLIFTON S. ARNOLD.

Witnesses:

JOHN B. SIMMONS,
BEN O. STURGES.