

(19)
(12)

(KR)
(A)

(51) 。 Int. Cl. 7
G02F 1/1337

(11)
(43)

2003-0037821
2003 05 16

(21) 10-2001-0068896
(22) 2001 11 06

(71) . 20

(72) 104-1002

(74)

:

(54)

, , - 가

, , , ,

6

1

2

3

4a, 4b 5 3

6

7

8

* * *

100 : 102 : 1

130 : 150 :

152 : 2 154 :

200 :

, -

,

,

, 가

, 가

, (dark)가

, (white)가

, 가

, 가

, 2

1

가

, (30) (40) (10) () (11) (20) () (30) (11) (10)

, 가 ()

, ()

, 가

, (50)

, 가

, (30)

, (20)

, (30)

, (10)

, (11)

2
 2a (1,5) (10) 가
 (1) (1) (10) ()
 1 (2) 1 (2) 'V'
 1 (2) (10) (3)
 (1) (5) (10) ()
 2 (6) 2 (6) 1 (2)
 (10) 1 (2) (7) 2 (6)
 가 1, 2 (2)(6) 1, 2 ()
 2)(6) 가 2b 가 1 (2) 2
 (6) 가 1, 2 (2)(6)
 1 (30) 2 (2)(6) (11) (10) 5μm (m
 2a 2b 1, 2 (30) 1, 2 (2)(6) (5)(1) - 가 1 : 1
 argin)
 가
 가
 3 4a, 4b 5 3
 6
 8 7 2 ()
 3 (100) 1 (100, 150) (130) 1 (102)
 () () (102)
 가 (150)
 () (152) 2 (152) (154) 2

1 (102)

(154) 2 (152) (154)
 (200) (200) (SiNx) (130)

(200) 2 (152) ()

(130) (200)

4a 1, 2 (102)(152) 가 (200)

4b (154) 2 (152) (130)
 (200) (200) , 1, 2 (102)(152)
 가 , 가 가 가

5 3 (200) (130) (200) (130)
 (200) (200)

가 가 가 , , ,
 가 가 (e) , (o) , (p)
 (eff) (200) (e) < (p) < (o) , (o) < (p)

가 (eff) < (p) 5
 (200)

(200) (eff)가 가 , (eff) = (p)가
 (tilt)

가 (p) < (eff)가 , 4a (200)
 180

가

6 1, 2 (102)(152) , 2 (152)
 (154) (130) (200)

(154) 2 (152) (200) (150)
 (100) (150)

가 가 가

7 (200) (e) < (p) < (o) , 가 (T)

(154) (200)

8 2 (152) (200)

(a), (b) (130) (200) 2 (152) (154) (130)

(154) (154) (200) (154) (200) (154) (200) (b)

(154) (154) (200)

가 가 가

가

(154) 가 (154)² (152) (200) (200) (150)

가 (100) (154) (150) 1 ~ 2μm

(57)

1.

2.

1

3.

1

4.

1

5.

1

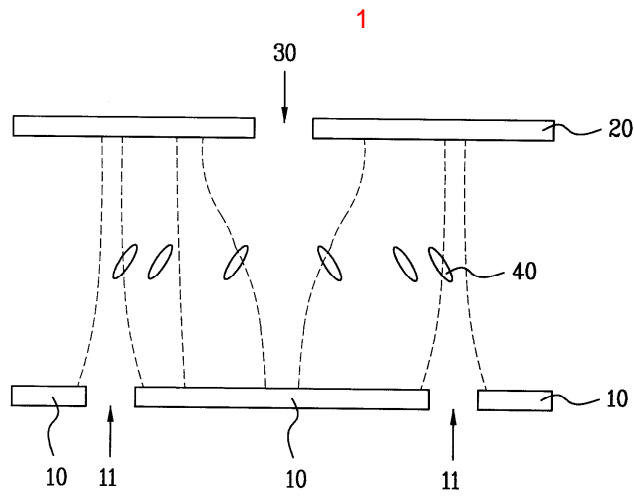

2a

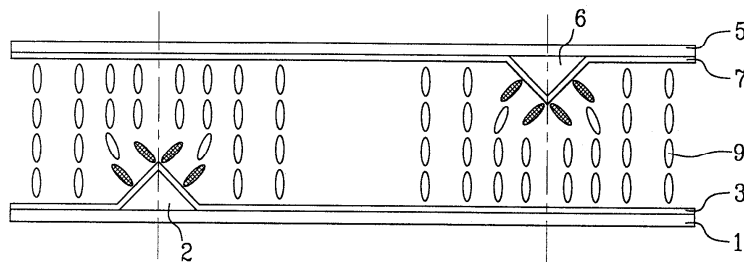

2b

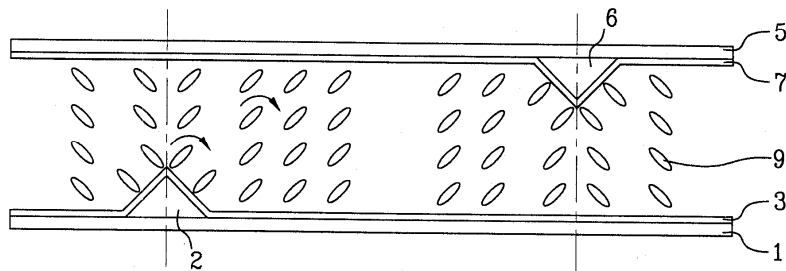

3

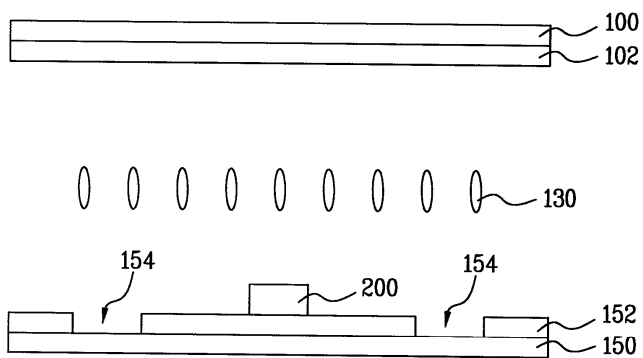

4a

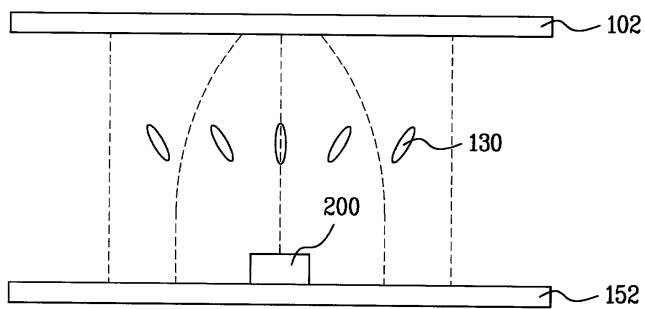

4b

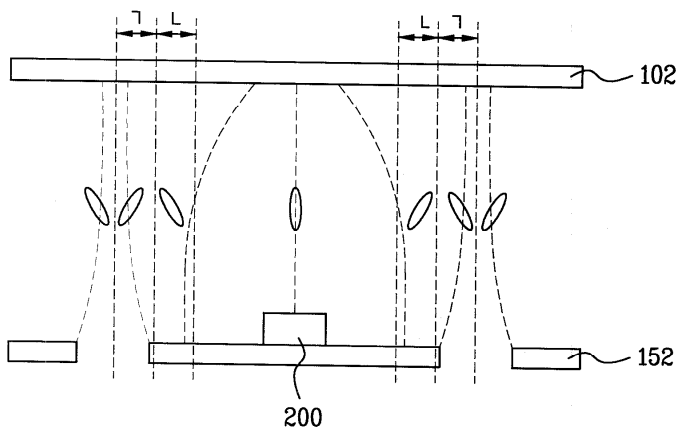

5

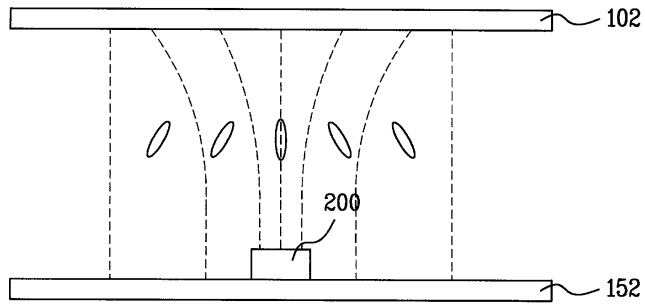

6

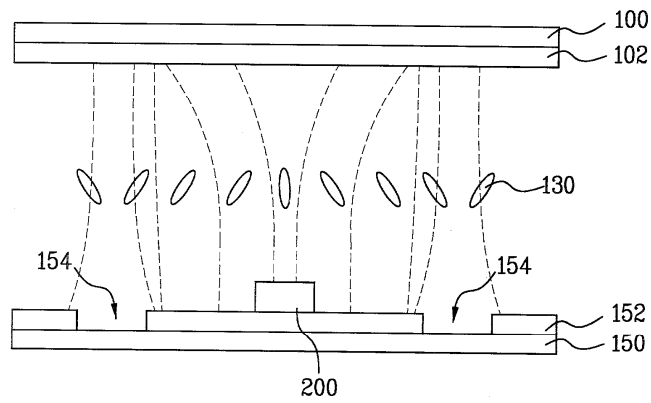

7

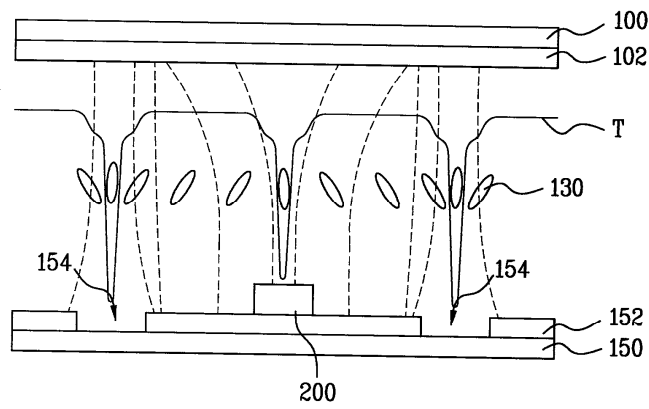

8

