

(19) World Intellectual Property Organization
International Bureau



(43) International Publication Date
20 April 2006 (20.04.2006)

PCT

(10) International Publication Number
WO 2006/041823 A2

(51) International Patent Classification:
H01L 29/76 (2006.01) H01L 29/94 (2006.01)

(21) International Application Number:
PCT/US2005/035620

(22) International Filing Date: 4 October 2005 (04.10.2005)

(25) Filing Language: English

(26) Publication Language: English

(30) Priority Data:
10/962,367 8 October 2004 (08.10.2004) US

(71) Applicant (for all designated States except US):
FAIRCHILD SEMICONDUCTOR CORPORATION [US/US]; 82 Running Hill Road, South Portland, Maine 04106-0022 (US).

(72) Inventors; and

(75) Inventors/Applicants (for US only): SHENOY, Praveen, Muraleedharan [IN/US]; 18B Wilkeswood Drive, Wilkes Barre, Pennsylvania 18707 (US). KOCON, Christopher, Boguslaw [US/US]; 5 Wildwood Lane, Mountaintop, Pennsylvania 18707 (US).

(74) Agents: SANI, Barmak et al.; Townsend and Townsend and Crew LLP, Two Embarcadero Center, 8th Floor, San Francisco, CA 94111-3834 (US).

(81) Designated States (unless otherwise indicated, for every kind of national protection available): AE, AG, AL, AM, AT, AU, AZ, BA, BB, BG, BR, BW, BY, BZ, CA, CH, CN, CO, CR, CU, CZ, DE, DK, DM, DZ, EC, EE, EG, ES, FI, GB, GD, GE, GH, GM, HR, HU, ID, IL, IN, IS, JP, KE, KG, KM, KP, KR, KZ, LC, LK, LR, LS, LT, LU, LV, LY, MA, MD, MG, MK, MN, MW, MX, MZ, NA, NG, NI, NO, NZ, OM, PG, PH, PL, PT, RO, RU, SC, SD, SE, SG, SK, SL, SM, SY, TJ, TM, TN, TR, TT, TZ, UA, UG, US, UZ, VC, VN, YU, ZA, ZM, ZW.

(84) Designated States (unless otherwise indicated, for every kind of regional protection available): ARIPO (BW, GH, GM, KE, LS, MW, MZ, NA, SD, SL, SZ, TZ, UG, ZM, ZW), Eurasian (AM, AZ, BY, KG, KZ, MD, RU, TJ, TM), European (AT, BE, BG, CH, CY, CZ, DE, DK, EE, ES, FI, FR, GB, GR, HU, IE, IS, IT, LT, LU, LV, MC, NL, PL, PT, RO, SE, SI, SK, TR), OAPI (BF, BJ, CF, CG, CI, CM, GA, GN, GQ, GW, ML, MR, NE, SN, TD, TG).

Published:
— without international search report and to be republished upon receipt of that report

[Continued on next page]

(54) Title: MOS-GATED TRANSISTOR WITH REDUCED MILLER CAPACITANCE

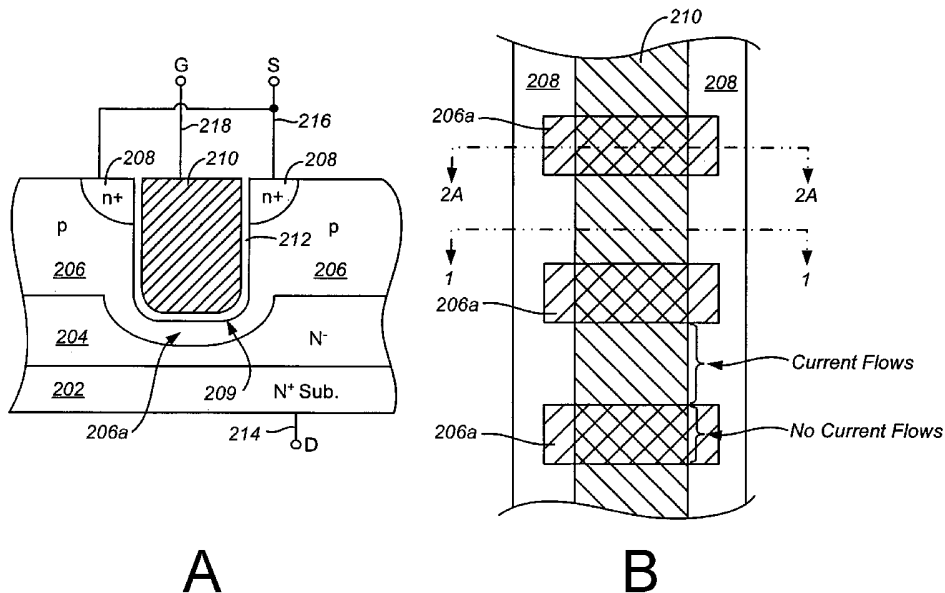

(57) Abstract: In one embodiment of the present invention, a trench MOS-gated transistor includes a first region of a first conductivity type forming a pn junction with a well region of a second conductivity type. The well region has a flat bottom portion and a portion extending deeper than the flat bottom portion. A gate trench extends into the well region. Channel regions extend in the well region along outer sidewalls of the gate trench. The gate trench has a first bottom portion which terminates within the first region, and a second bottom portion which terminates within the deeper portion of the well region such that when the transistor is in an on state the deeper portion of the well region prevents a current from flowing through those channel region portions located directly above the deeper portion of the well region.

WO 2006/041823 A2



For two-letter codes and other abbreviations, refer to the "Guidance Notes on Codes and Abbreviations" appearing at the beginning of each regular issue of the PCT Gazette.

MOS-GATED TRANSISTOR WITH REDUCED MILLER CAPACITANCE

BACKGROUND OF THE INVENTION

5 [0001] This invention relates in general to semiconductor power devices and in particular to a trench MOS-gated transistor with reduced miller capacitance.

[0002] Fig. 1 shows a simplified cross-section view of a conventional vertical trenched gate MOSFET 100. An epitaxial layer 104 of n-type conductivity type extends over n-type substrate 102 which forms the drain contact region. Well region 106 of p-type conductivity type is formed in an upper portion of epitaxial layer 104. Gate trench 109 extends through well region 106 and terminates just below the interface between epitaxial layer 104 and well region 106. Gate trench 109 is lined with a dielectric layer 112 along its sidewalls and bottom, and is filled with polysilicon material 110 forming the transistor gate. Source regions 108 flank each side of trench 109, and overlap gate 110 along the vertical dimension. In the on-state, a current flows vertically from drain terminal 114 to source terminal 116 through substrate 102, epitaxial layer 104, channel regions in well region 106 along the outer sidewalls of trench 109, and finally source regions 108.

[0003] Epitaxial layer 104 together with substrate 102 form the drain region. As can be seen, gate 110 overlaps the drain region along the bottom of trench 109. It is desirable to minimize this gate-drain overlap in order to improve the transistor switching speed. The gate-drain charge Q_{gd} is proportional to this overlap area and inversely proportional to the thickness of the dielectric along the bottom of trench 109. Several methods to reduce Q_{gd} have been proposed including reducing the trench width, using thicker dielectric along the trench bottom, eliminating portions of the gate along the trench flat bottom portion, and extending the p-type well region slightly deeper than the trench. Each of these techniques has its own advantages and disadvantages. Some require a more complex process technology, while others are not as effective in reducing Q_{gd} without adversely impacting other device characteristics.

[0004] Thus, an MOS-gated transistor with improved characteristics including a substantially reduced miller capacitance, and which is simple to manufacture is desirable.

BRIEF SUMMARY OF THE INVENTION

[0005] In accordance with an embodiment of the present invention, a trench MOS-gated transistor includes a first region of a first conductivity type forming a pn junction with a well region of a second conductivity type. The well region has a flat bottom portion and a portion extending deeper than the flat bottom portion. A gate trench extends into the well region. Channel regions extend in the well region along outer sidewalls of the gate trench. The gate trench has a first bottom portion which terminates within the first region and a second portion which terminates within the deeper portion of the well region such that when the transistor is in an on state the deeper portion of the well region prevents a current from flowing through those channel region portions located directly above the deeper portion of the well region.

[0006] In accordance with another embodiment of the present invention, a trench MOS-gated transistor includes a silicon layer of a first conductivity type over a silicon substrate. A well region of a second conductivity type is formed in an upper portion of the silicon layer. A gate trench extends through the well region and terminates within the silicon layer. Source regions of the first conductivity type flank each side of the gate trench. The gate trench is filled with a polysilicon material at least up to and partially overlapping with the source regions. A silicon region of the second conductivity type extends along a bottom portion of the trench such that a gap is formed between the silicon region and the well region through which gap a current flows when the transistor is in an on state.

[0007] In accordance with another embodiment of the invention, a trench MOS-gated transistor is formed as follows. A first region of a first conductivity type is provided. A well region of a second conductivity type is then formed in an upper portion of the first region. A trench is formed which extends through the well region and terminates within the first region. Dopants of the second conductivity type are implanted along predefined portions of the bottom of the trench to form regions along the bottom of the trench which are contiguous with the well region such that when the transistor is in an on state the deeper portion of the well region prevents a current from flowing through those channel region portions located directly above the deeper portion of the well region.

[0008] In accordance with yet another embodiment of the invention, a trench MOS-gated transistor is formed as follows. An epitaxial layer of a first conductivity type is formed over a substrate. A well region of a second conductivity type is formed in an upper portion of the epitaxial layer. A trench is formed which extends through the well region and terminates

within the epitaxial layer. Dopants of the second conductivity type are implanted along the bottom of the trench to form a region of the second conductivity type extending along a bottom portion of the trench such that a gap is formed between the region of the second conductivity type and the well region through which gap a current flows when the transistor is in an on state.

[0009] These and other embodiments of the invention will be described with reference to the accompanying drawings and following detailed description.

BRIEF DESCRIPTION OF THE DRAWINGS

[0010] Fig. 1 shows a simplified cross-section view of a conventional vertical trenched gate MOSFET;

[0011] Fig. 2A shows a simplified cross section view of a vertical trenched-gate MOSFET in accordance with an embodiment of the present invention;

[0012] Fig. 2B shows a simplified top layout view of the vertical trenched-gate MOSFET in Fig. 2A;

[0013] Fig. 3 shows a simplified cross section view of a vertical trenched-gate MOSFET in accordance with another embodiment of the present invention.

[0014] Fig. 4 shows a simplified top layout view of an alternate embodiment of the present invention wherein the cell structures in Figs. 2A and 3 are combined;

[0015] Fig. 5 shows the current and voltage waveforms for the Fig. 2A MOSFET embodiment versus those for the prior art Fig. 1 MOSFET; and

[0016] Fig. 6 shows current and voltage waveforms for the Fig. 3 MOSFET versus those for the prior art Fig. 1 MOSFET.

DETAILED DESCRIPTION OF THE INVENTION

[0017] In accordance with an embodiment of the invention, the gate-drain capacitance of a MOSFET is reduced by using an implant region under the trenched gate wherein the implant region is contiguous with the well region of the MOSFET. The implant region makes the area of the trench under which it is formed inactive as it blocks conduction in the corresponding portion of the transistor channel. One suitable application for this embodiment would be high voltage devices in which the contribution of the channel resistance to the

transistor on resistance R_{dson} is low. In another embodiment, an implant region under the gate trench is formed such that there is a gap between the implant region and the well region through which the channel current can flow. In this embodiment, the impact of the implant region on R_{dson} is minimized, and thus a suitable application for this embodiment would be

5 low voltage devices. Both these embodiments are particularly useful in designs requiring a tight trench cell pitch such as tight alternating pn pillar pitch of a superjunction device or low R_{dson} . These two embodiments may be combined together in a single MOSFET.

Alternatively, one of both of these embodiments may be combined with the prior art structure shown in Fig. 1 as needed.

10 **[0018]** Fig. 2A shows a simplified cross section view of a vertical trench-gate MOSFET 200 in accordance with an embodiment of the present invention. An epitaxial layer 204 of n-type conductivity type extends over n-type substrate 202 which forms the drain contact region. Well region 206 of p-type conductivity type is formed in an upper portion of epitaxial layer 204. Gate trench 209 extends through well region 206. A portion 206a of

15 well region 206 directly below trench 209 extends deeper into epitaxial layer 204 than other portions of well region 206 such that gate trench 209 terminates within portion 206a. Gate trench 209 is lined with a dielectric layer 212 along its sidewalls and bottom. Trench 209 is filled with polysilicon material 210 forming the transistor gate. Source regions 208 flank each side of trench 209 and overlap gate 210 along the vertical dimension. In an alternate

20 embodiment, trench 209 is partially filled with polysilicon material with dielectric material atop the polysilicon. Note that one or more of substrate 202, epitaxial layer 204, well region 206 including portion 206a, and source regions 208 may be from crystalline silicon (Si), silicon carbide (SiC), gallium nitride (GaN), or silicon germanium (SiGe).

[0019] In Fig. 2A, because gate 210 does not overlap epitaxial layer 204, no channel is

25 formed above portion 206a in the on state. In one variation of the Fig. 2A embodiment, the trench-gate cell is stripe shape (i.e., is laid out in an open cell configuration) as shown in the simplified top layout view in Fig. 2B. Stripe-shaped trench-gate 210 extends vertically with source regions 208 flanking each side of trench-gate electrode 210. As shown, deeper extending well portions 206a are formed periodically along a length of the striped trench-gate electrode 210. Where portion 206a is not formed (e.g., along dashed line 1-1) the cell

30 cross section is similar to that in Fig. 1 (i.e., gate trench 210 extends clear through well region 206 and terminates within epitaxial layer 204 such the gate trench overlaps epitaxial layer 204 along the vertical dimension). In this manner, in the on state, current flow is established

(in a similar manner to that described above in reference to Fig. 1) along those portions of the trench sidewalls below which deeper extending well portions 206a are not formed. Current flow is however blocked where deeper extending well portions 206a are formed under the gate. The gate-drain overlap is thus reduced by an amount corresponding to portions 206a.

5 Further, since the total well region 206 is increased in size, the gate to source capacitance or Q_{gs} increases. Thus, the Q_{gd}/Q_{gs} ratio advantageously decreases further. The switching characteristics of the MOSFET are therefore substantially improved.

[0020] In one embodiment, the Fig. 2A structure is formed as follows. Epitaxial layer 204 is formed over substrate 202 using conventional techniques. Well region 206 is formed in an upper portion of epitaxial layer 204 by implanting and driving in p-type dopants using known techniques. Trench 209 is then formed by etching the silicon using conventional silicon etch techniques. Using a masking layer, the bottom of trench 209 is then selectively implanted with p-type dopants to thus form regions 206a. In one embodiment, an implant dose in the range of 1×10^{13} - 1×10^{14} cm^{-3} and an implant energy in the range of 40-120KeV are used. In another embodiment, the thickness of region 206a at its deepest point is in the range of 0.2-0.4 μm . Dielectric layer 212, doped polysilicon 2210 filling trench 209, and source regions 208 are all formed using conventional methods.

[0021] Fig. 3 shows a simplified cross section view of a vertical trenched-gate MOSFET 300 in accordance with another embodiment of the present invention. Cross section view of MOSFET 300 is similar to that in Fig. 2A except that instead of the deeper extending well portion 206a, p-type region 307 is formed directly below trench 309. As shown in Fig. 3, region 307 is formed such that there is a gap between well region 306 and region 307 at each of the bottom corners of trench 309. During the on state, current flows through these gaps. Thus, by using region 307 with gaps as shown, the gate-drain overlap is significantly reduced without blocking the current flow. In one embodiment, region 307 is formed by carrying out a shallow boron implant through the bottom the trench using an implant energy in the range of 30-80KeV. In one embodiment, region 307 has a thickness in the range of 0.1-0.3 μm , and the gap between region 307 and well region 306 is in the range of 0.1-0.3 μm . As in the Fig. 2A embodiment, one or more of substrate 302, epitaxial layer 304, well region 306, region 307, and source regions 308 may be from crystalline silicon (Si), silicon carbide (SiC), gallium nitride (GaN), or silicon germanium (SiGe).

[0022] In the stripe-shaped cell layout embodiment, region 307 may be continuous along the length of the striped trench gate. Region 307 may be extended up at the ends of or other locations along the striped trench gate to electrically contact well region 306. Alternatively, region 307 is not biased and thus is allowed to electrically float. In an alternate embodiment, similar to the layout shown in Fig. 2B, a number of p-type regions 307 are formed periodically along the length of the stripe such that the cell structure along portions of the stripe (e.g., at dashed line 1-1) is similar to that in prior art Fig. 1. Alternatively, the Fig. 2A and Fig. 3 embodiments may be combined as shown in the layout diagram in Fig. 4. In Fig. 4, regions 206a correspond to region 206a in Fig. 2A and regions 307 correspond to region 307 in Fig. 3. As indicated by the two arrows, no current conduction occurs where regions 206a are formed, but current can flow where regions 307 are formed as well as between regions 206a and 307. The particular arrangement of regions 307 and 206a is not limited to that shown in Fig. 4. Many other arrangements are possible. In yet another embodiment, the regions between regions 206a and 307 are eliminated such that nowhere along the stripe is a cell structure similar to that shown in the prior art Fig. 1 is formed.

[0023] In one embodiment of the invention, the well region 206 and region 206a under the gate trench in Fig. 2A, and the well region 306 and the region 307 under the gate trench in Fig. 3 may be formed as follows. A shallow blanket implant (in the active region) of p-type dopants into the epitaxial layer is carried out. A deep implant of p-type dopants into selected areas of the epitaxial layer is then carried out using a masking layer. These two implant steps may be carried out in reverse order. A temperature cycle is then carried out to drive both implanted dopants deeper into the epitaxial layer. As a result, a well region corresponding to the shallow blanket implant and predefined silicon regions corresponding to the deep implant are formed in the epitaxial layer such that the deepest portion of the predefined silicon regions is deeper than a bottom surface of the well region. To obtain the structure in Fig. 2A, the above two implant steps and the temperature cycle need to be designed so that after driving in the dopants, the silicon regions are contiguous with the well regions. Alternatively, to form the structure in Fig. 3, the two implant steps and the temperature cycle need to be designed so that after the dopants are driven in and the gate trench is formed, a gap is formed between each of the silicon regions and the well region. In view of this disclosure, one skilled in the art would know how to design the two implant steps and the temperature cycle in order to obtain the structures shown in Figs. 2A and 3.

[0024] In another method of forming the well region 206 and region 206a under the gate trench in Fig. 2A, and the well region 306 and the region 307 under the gate trench in Fig. 3, a shallow implant of p-type dopants into selected areas of the epitaxial layer is first carried out using a masking layer. A temperature cycle is then performed to drive the implanted dopants deeper into the epitaxial layer. A blanket implant (in the active region) of p-type dopants into the first silicon region is then carried out. A second temperature cycle is then performed to drive the implanted dopants from the blanket implant step deeper into the epitaxial layer and to drive the dopants from the shallow implant step even deeper into the epitaxial layer. As a result, a well region corresponding to the blanket implant and silicon regions corresponding to the shallow implant are formed such that the deepest portion of the silicon regions is deeper than a bottom surface of the well region. To obtain the structure in Fig. 2A, the above two implant steps and two temperature cycles need to be designed so that after driving in the dopants the silicon regions are contiguous with the well regions. Alternatively, to form the structure in Fig. 3, the two implant steps and the two implant steps need to be designed so that after the dopants are driven in and the gate trench is formed, a gap is formed between each of the silicon regions and the well region. As with the preceding embodiment, in view of this disclosure, one skilled in the art would know how to design the two the implant steps and the two temperature cycles in order to obtain the structures shown in Figs. 2A and 3.

[0025] The table below shows the simulation results for Q_{gs} , Q_{gd} , and Q_{gd}/Q_{gs} ratio for each of MOSFET 100 in prior art Fig. 1, MOSFET 200 in Fig. 2A, and MOSFET 300 in Fig. 3. A 600V superjunction MOSFET with a $6\mu\text{m}$ pitch and $0.6\mu\text{m}$ trench width was used for the simulation.

Parameter	Fig. 1	Fig. 2A	Fig. 3
Q_{gs} nC/cm ²	72.8	103.8	73.2
Q_{gd} nC/cm ²	36.4	27.3	31.6
Q_{gd}/Q_{gs}	0.50	0.26	0.43

[0026] As can be seen MOSFETS 200 and 300 both have lower Q_{gd} than prior art MOSFET 100, and both have higher Q_{gs} than prior art MOSFET 100. A lower Q_{gd}/Q_{gs} ratio is thus obtained for both MOSFETs 200 and 300 than that for MOSFET 100. The simulation waveforms in Figs. 5 and 6 show similar results. Fig. 5 shows the I_{drain} , V_{drain} ,

and V_{gate} for the Fig. 2A MOSFET and for the prior art Fig. 1 MOSFET, and Fig. 6 shows the same parameters for the Fig. 3 MOSFET and the prior art Fig. 1 MOSFET.

5 [0027] The cross-section views and top layout view of the different embodiments may not be to scale, and as such are not intended to limit the possible variations in the layout design of the corresponding structures. Also, the various transistors can be formed in cellular architecture including hexagonal or square shaped transistor cells.

10 [0028] Although a number of specific embodiments are shown and described above, embodiments of the invention are not limited thereto. For example, it is understood that the doping polarities of the structures shown and described could be reversed and/or the doping concentrations of the various elements could be altered without departing from the invention. As another example, the various exemplary vertical transistors described above have the trenches terminating in the drift regions, but they can also terminate in the more heavily doped substrate. As yet another example, the present invention is shown and described in the context of vertical MOSFET embodiments, but regions 206a in Fig. 2A and 307 in Fig. 3 can be similarly formed in other trenched gate structures such as trenched gate IGBTs and lateral trenched gate MOSFETs.

15 [0029] Therefore, the scope of the present invention should be determined not with reference to the above description but should, instead, be determined with reference to the appended claim, along with their full scope of equivalents.

WHAT IS CLAIMED IS:

1 1. A trench MOS-gated transistor comprising:
2 a first region of a first conductivity type;
3 a well region of a second conductivity type forming a pn junction with the first
4 region, the well region having a flat bottom portion and a portion extending deeper than the
5 flat bottom portion;
6 a gate trench extending into the well region; and
7 channel regions in the well region along outer sidewalls of the gate trench,
8 wherein a first bottom portion of the gate trench terminates within the first region and a
9 second bottom portion of the gate trench terminates within the deeper portion of the well
10 region such that when the transistor is in an on state the deeper portion of the well region
11 prevents a current from flowing through those channel region portions located directly above
12 the deeper portion of the well region.

1 2. The trench MOS-gated transistor of claim 1 further comprising:
2 a substrate of the first conductivity type, wherein the first region is an epitaxial
3 layer extending over the substrate.

1 3. The trench MOS-gated transistor of claim 1 further comprising:
2 source regions of the first conductivity type in the well region, the source
3 regions flanking each side of the gate trench.

1 4. The trench MOS-gated transistor of claim 1 wherein the gate trench
2 comprises a dielectric layer lining the sidewalls and bottom of the gate trench, and the gate
3 trench is at least partially filled with polysilicon.

1 5. The trench MOS-gated transistor of claim 1 wherein at its deepest
2 point in the first region, the deeper portion of the well region is about 0.2-0.4 μ m deeper than
3 the flat bottom portion of the well region.

1 6. The trench MOS-gated transistor of claim 1 further comprising a
2 second region of the second conductivity type in the first region, a third bottom portion of the
3 gate trench terminating within the second region, the second region being spaced from the
4 well region to form a gap therebetween, wherein a current flows through the gap when the
5 transistor is in an on state.

1 7. The trench MOS-gated transistor of claim 1 wherein at least one of the
2 first region and the well region is from one of crystalline silicon (Si), silicon carbide (SiC),
3 gallium nitride (GaN), and silicon germanium (SiGe).

1 8. A trench MOS-gated transistor comprising:
2 a substrate;
3 an epitaxial layer of a first conductivity type extending over and in contact
4 with the substrate;
5 a well region of a second conductivity type formed in an upper portion of the
6 epitaxial layer, the well region having a flat bottom portion and a plurality of portions
7 extending deeper than the flat bottom portion;
8 a plurality of gate trenches extending into the well region; and
9 source regions of the first conductivity type formed in an upper portion of the
10 well region, the source regions flanking each side of the plurality of trenches so as to form
11 channel regions in the well region along outer sidewalls of each of the plurality of gate
12 trenches, each of the plurality of gate trenches having a first plurality of bottom portions
13 which extend through the well region and terminate within the epitaxial layer and a second
14 plurality of bottom portions each terminating within a corresponding one of the plurality of
15 deeper portions of the well region such that when the transistor is in an on state the plurality
16 of deeper portions of the well region prevent a current from flowing through those channel
17 region portions located directly above the deeper portions of the well region.

1 9. The trench MOS-gated transistor of claim 8 wherein at their deepest
2 point in the epitaxial layer, the plurality of deeper portions of the well region are about 0.2-
3 0.4 μ m deeper than the flat bottom portion of the well region.

1 10. The trench MOS-gated transistor of claim 8 further comprising a
2 plurality of regions of the second conductivity type in the epitaxial layer, a third plurality of
3 bottom portions of each gate trench terminating within a corresponding one of the plurality of
4 regions of the second conductivity type, the plurality of regions of the second conductivity
5 type being spaced from the well region to form a gap therebetween, wherein a current flows
6 through the gap when the transistor is in an on state.

1 11. The trench MOS-gated transistor of claim 8 wherein each of the
2 plurality of gate trenches comprises a dielectric layer lining the sidewalls and bottom of the
3 gate trench, and each gate trench is at least partially filled with polysilicon.

1 12. The trench MOS-gated transistor of claim 8 wherein at least one of the
2 substrate, the epitaxial layer, the well region, and the source regions is from one of crystalline
3 silicon (Si), silicon carbide (SiC), gallium nitride (GaN), and silicon germanium (SiGe).

1 13. A trench MOS-gated transistor comprising:
2 a substrate of silicon material;
3 a layer of silicon material of a first conductivity type over the substrate;
4 a well region of a second conductivity type formed in an upper portion of the
5 layer of silicon material;
6 a gate trench extending into the well region;
7 a source region of the first conductivity type flanking each side of the gate
8 trench so as to form channel regions in the well region along outer sidewalls of the gate
9 trench, the gate trench being filled with a polysilicon material at least up to and partially
10 overlapping with the source regions; and
11 a region of silicon material of the second conductivity type surrounding a
12 bottom portion of the trench such that a gap is formed between the region of silicon material
13 and the well region through which gap a current flows when the transistor is in an on state.

1 14. The trench MOS-gated transistor of claim 13 wherein the layer of
2 silicon material is an epitaxial layer extending over the substrate.

1 15. The trench MOS-gated transistor of claim 13 wherein the region of
2 silicon material has a thickness in the range of 0.1-0.3 μ m.

1 16. The trench MOS-gated transistor of claim 13 wherein the trench gate is
2 stripe shaped and the region of silicon material partially extends along a length of the striped
3 trench gate.

1 17. The trench MOS-gated transistor of claim 13 wherein the trench gate is
2 stripe shaped and the region of silicon material extends along an entire length of the striped
3 trench gate.

1 18. The trench MOS-gated transistor of claim 17 wherein the region of
2 silicon material is electrically connected to the well region.

1 19. The trench MOS-gated transistor of claim 13 wherein the region of
2 silicon material electrically floats.

1 20. The trench MOS-gated transistor of claim 13 wherein the well region
2 has a flat bottom portion and a portion extending deeper than the flat bottom portion such that
3 portions of the gate trench terminate within the deeper portion of the well region.

1 21. A method of forming a trench MOS-gated transistor, the method
2 comprising:

3 providing a first region of a first conductivity type;

4 forming a well region of a second conductivity type in an upper portion of the
5 first region;

6 forming a trench extending through the well region and terminating within the
7 first region, portions of the well region extending along the trench sidewalls forming channel
8 regions; and

9 implanting dopants of the second conductivity type along predefined portions
10 of the bottom of the trench to form a plurality of second regions extending deeper than a
11 bottom surface of the well region, each of the plurality of second regions being contiguous
12 with the well region such that when the transistor is in an on state the plurality of second
13 regions prevent a current from flowing through those channel region portions located directly
14 above the plurality of second regions.

1 22. The method of claim 21 wherein the first region is an epitaxial layer,
2 the method further comprising:

3 forming the epitaxial layer over a substrate of the first conductivity type.

1 23. The method of claim 21 further comprising:

2 lining the trench sidewalls and bottom with dielectric layer;

3 at least partially filling the trench with polysilicon material; and

4 forming source regions of the first conductivity type in the well region, the
5 source regions flanking each side of the gate trench.

1 24. The method of claim 21 wherein at least one of the first region, the
2 well region, and the plurality of second regions is from one of crystalline silicon (Si), silicon
3 carbide (SiC), gallium nitride (GaN), and silicon germanium (SiGe).

1 25. A method of forming a trench MOS-gated transistor, the method
2 comprising:
3 providing a silicon substrate;
4 forming a silicon epitaxial layer of a first conductivity type over the substrate;
5 forming a well region of a second conductivity type in an upper portion of the
6 silicon epitaxial layer;
7 forming a trench extending through the well region and terminating within the
8 epitaxial silicon layer;
9 implanting dopants of the second conductivity type along the bottom of the
10 trench to form a region of the second conductivity type extending along a bottom portion of
11 the trench such that a gap is formed between the silicon region and the well region through
12 which gap a current flows when the transistor is in an on state;
13 forming source regions of the first conductivity type flanking each side of the
14 trench, whereby portions of the well region extending along outer sidewalls of each of the
15 plurality of gate trenches form channel regions; and
16 filling the trench with a polysilicon material at least up to and partially
17 overlapping with the source regions.

1 26. The method of claim 25 further comprising:
2 forming source regions of the first conductivity type flanking each side of the
3 trench; and
4 filling the trench with a polysilicon material at least up to and partially
5 overlapping with the source regions.

1 27. The method of claim 25 wherein the silicon region has a thickness in
2 the range of 0.1-0.3 μ m.

1 28. A method of forming a trench MOS-gated transistor, the method
2 comprising:
3 providing a first region of a first conductivity type;

4 performing a shallow implant of dopants of a second conductivity type into the
5 first region;
6 performing a deep implant of dopant of the second conductivity type into the
7 first region;
8 performing a temperature cycle after the deep and shallow implant steps to
9 drive the respective implanted dopants deeper into the first region to thereby form a well
10 region corresponding to the shallow implant and a second region corresponding to the deep
11 implant, the deepest portion of the second region being deeper than a bottom surface of the
12 well region; and
13 forming a trench having a first portion extending through the well region and
14 terminating within the first region and a second portion extending through the well region and
15 terminating within the second region.

1 29. The method of claim 28 wherein portions of the well region extending
2 along sidewalls of the trench form channel regions, and wherein after the temperature cycle
3 the second region is contiguous with the well region such that the second region prevents a
4 current from flowing through those channel region portions located directly above the second
5 region.

1 30. The method of claim 28 wherein after the temperature cycle the second
2 region is spaced from the well region such that after the trench is formed the spacing between
3 the second region and the well region forms a gap through which a current flows when the
4 transistor is in an on state.

1 31. The method of claim 28 wherein the deep implant step is carried out
2 using a masking layer.

1 32. The method of claim 28 wherein at least one of the first region, the
2 well region, and the second region is from one of crystalline silicon (Si), silicon carbide
3 (SiC), gallium nitride (GaN), and silicon germanium (SiGe).

1 33. A method of forming a trench MOS-gated transistor, the method
2 comprising:
3 providing a first region of a first conductivity type;
4 performing a shallow implant of dopants of a second conductivity type into the
5 first region;

6 performing a temperature cycle to drive the implanted dopants deeper into the
7 first region;
8 performing a second implant of dopants of the second conductivity type into
9 the first region;
10 performing a temperature cycle to drive the implanted dopants from the
11 second implant step deeper into the silicon region and to drive the dopants from the shallow
12 implant step even deeper into the silicon to thereby form a well region corresponding to the
13 second implant and a second region corresponding to the shallow implant, the deepest portion
14 of the second region being deeper than a bottom surface of the well region; and
15 forming a trench having a first portion extending through the well region and
16 terminating within the silicon region and a second portion extending through the well region
17 and terminating within the second region

1 34. The method of claim 33 wherein portions of the well region extending
2 along sidewalls of the trench form channel regions, and after the temperature cycle the
3 second region is contiguous with the well region such that the second region prevents a
4 current from flowing through those channel region portions located directly above the second
5 region.

1 35. The method of claim 33 wherein after the temperature cycle the second
2 region is spaced from the well region such that after the trench is formed the spacing between
3 the second region and the well region forms a gap through which a current flows when the
4 transistor is in an on state.

1 36. The method of claim 33 wherein at least one of the first region, the
2 well region, and the second region is from one of crystalline silicon (Si), silicon carbide
3 (SiC), gallium nitride (GaN), and silicon germanium (SiGe).

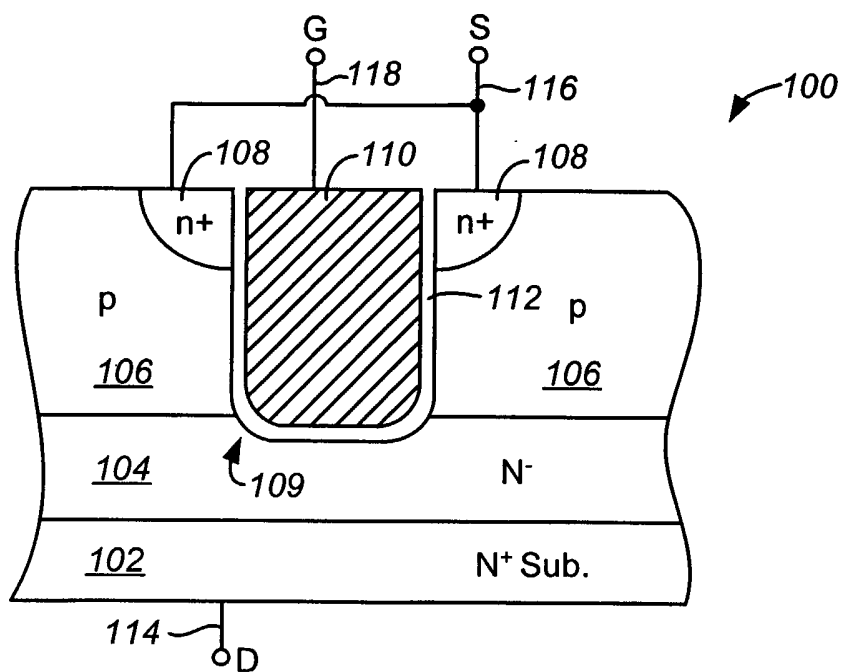

FIG. 1
(Prior Art)



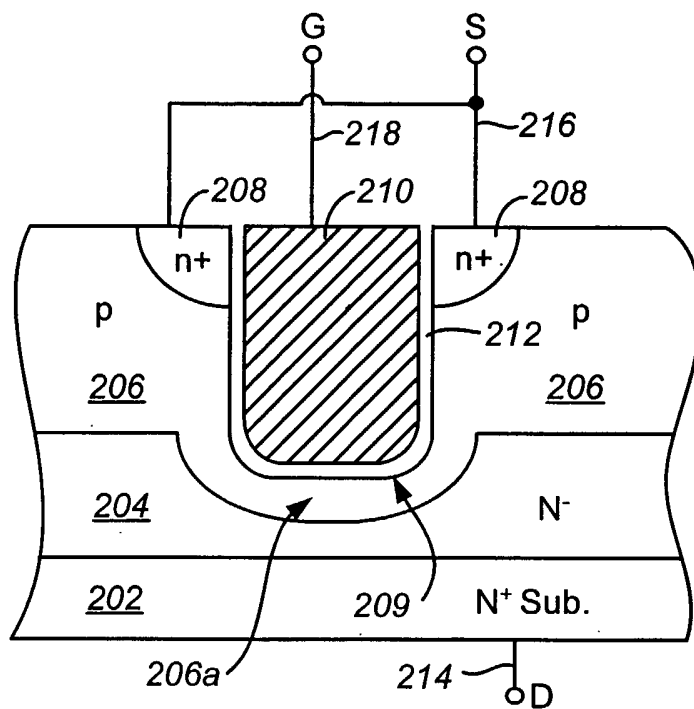

FIG. 2A



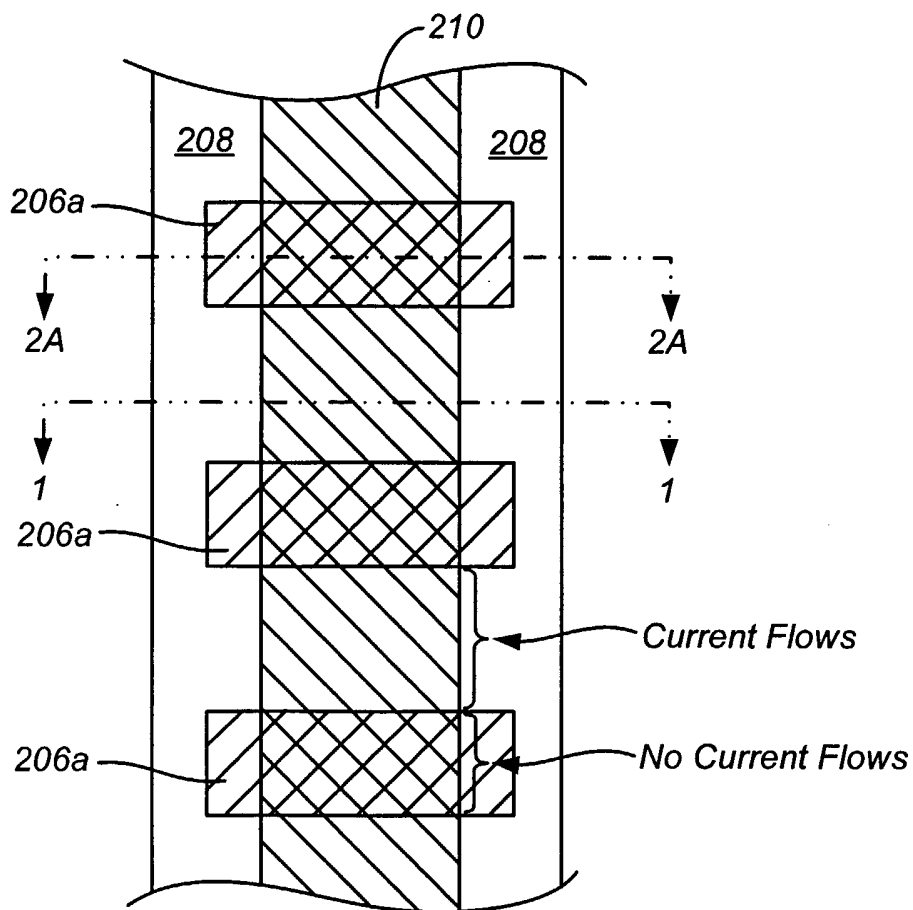

FIG. 2B



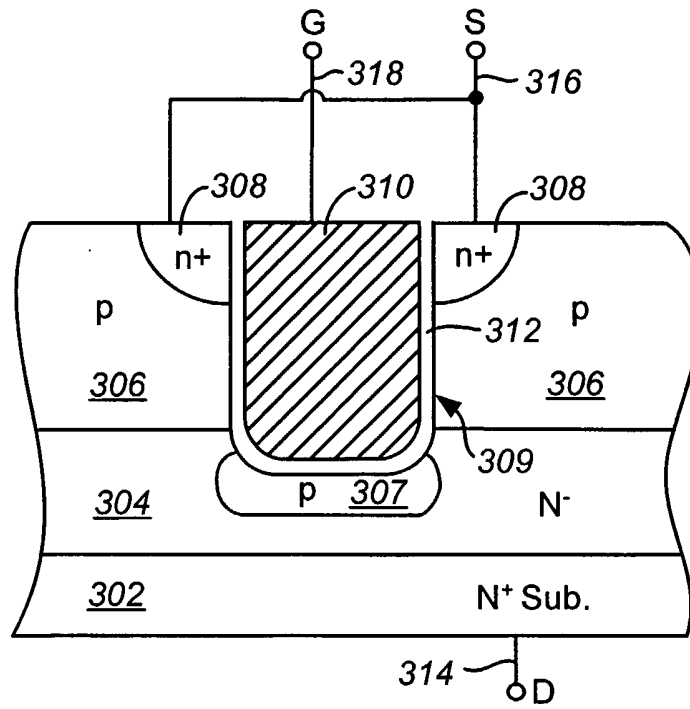

FIG. 3



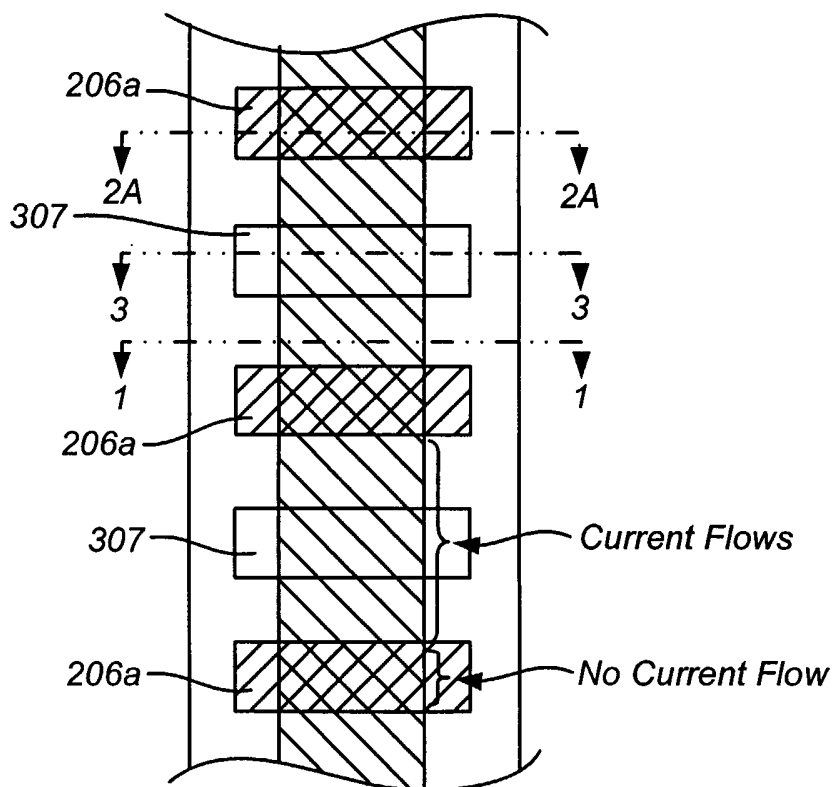

FIG. 4



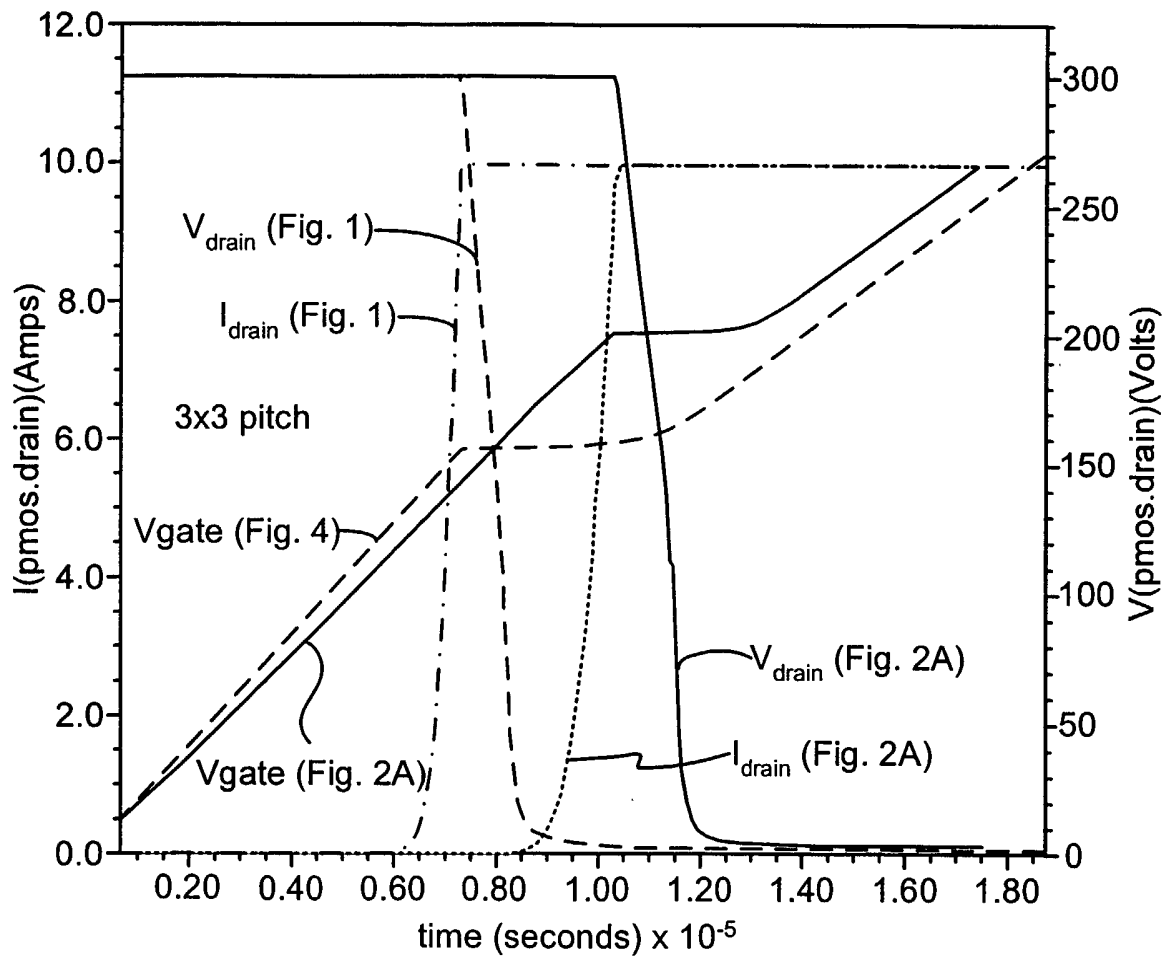

FIG. 5

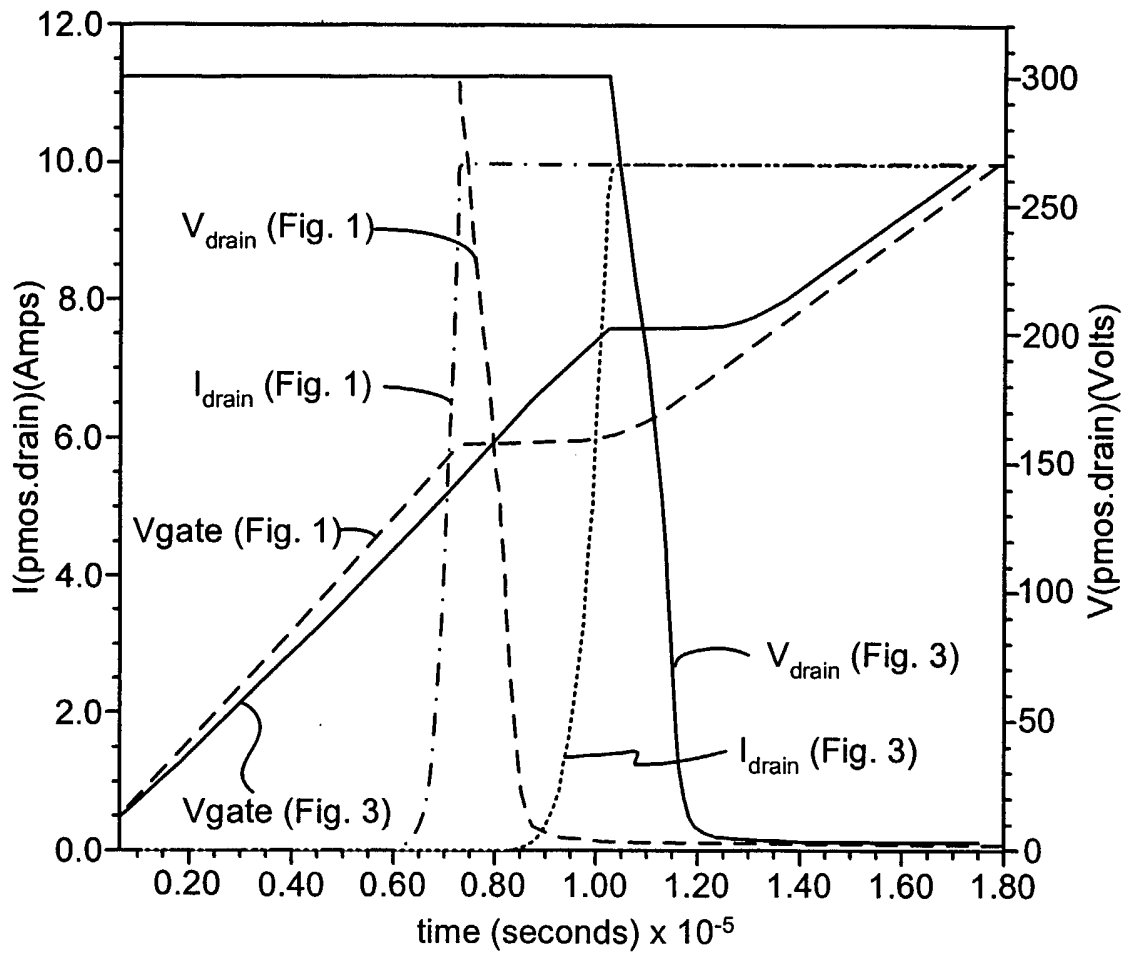

FIG. 6