

No. 751,878.

PATENTED FEB. 9, 1904.

S. C. SPANGLER.
FRICTION GEAR.

APPLICATION FILED MAR. 11, 1903.

NO MODEL.

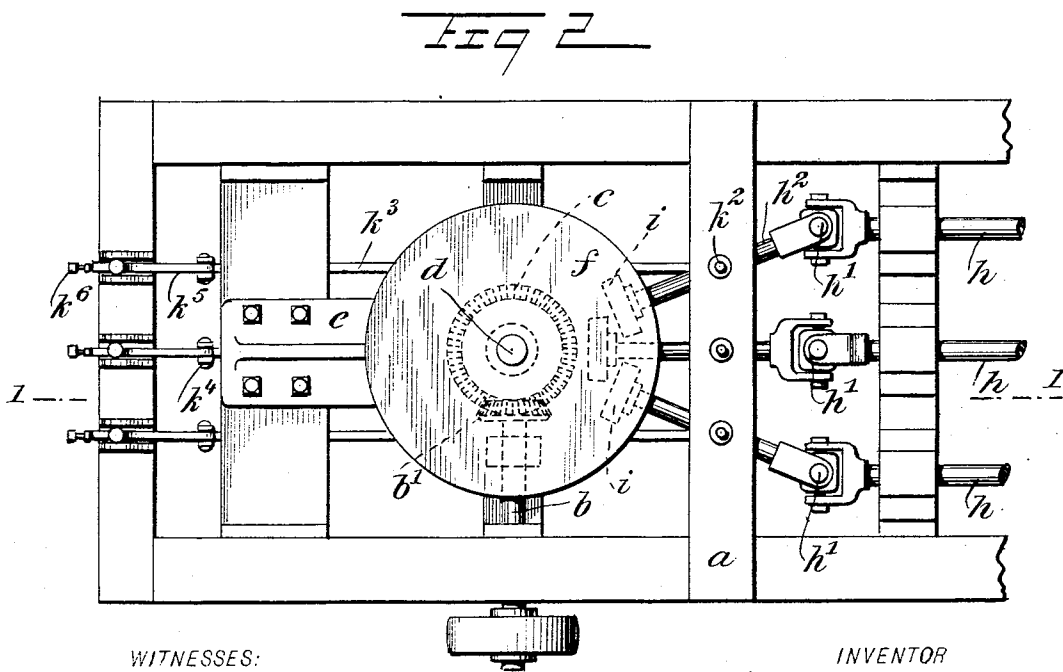
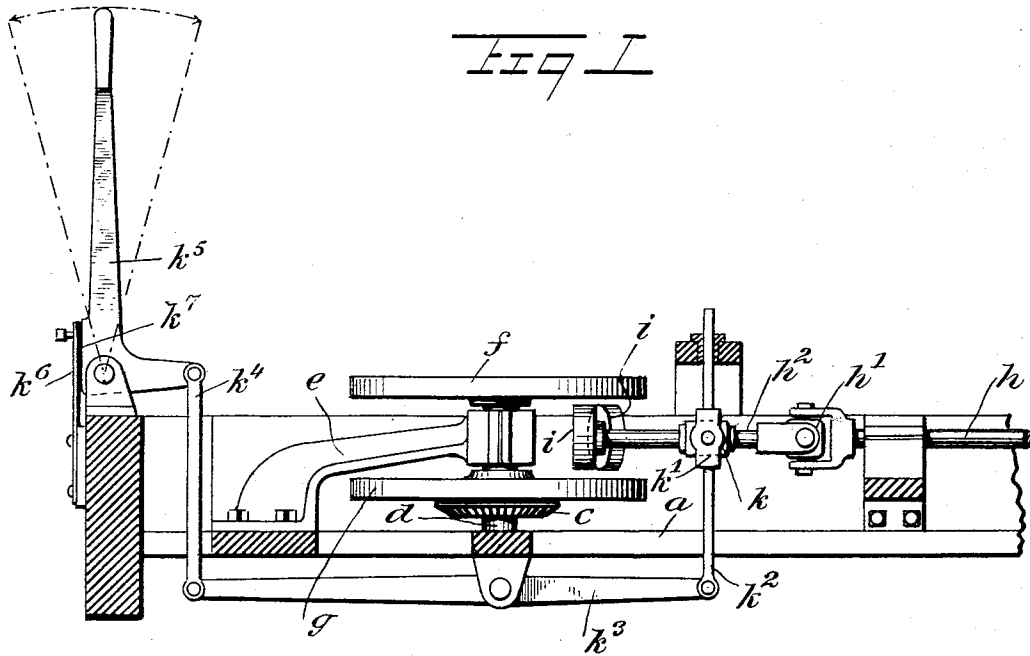

WITNESSES:

W. Walker
Isaac B. Owens.

INVENTOR

Samuel C. Spangler

BY

Munn

ATTORNEYS:

UNITED STATES PATENT OFFICE.

SAMUEL C. SPANGLER, OF CLYDE, OKLAHOMA TERRITORY, ASSIGNOR OF ONE-HALF TO OLOFF P. SWENSON AND JOHN A. SWENSON, OF MEDFORD, OKLAHOMA TERRITORY.

FRICITION-GEAR.

SPECIFICATION forming part of Letters Patent No. 751,878, dated February 9, 1904.

Original application filed October 29, 1901, Serial No. 80,410. Divided and this application filed March 11, 1903. Serial No. 147,270. (No model.)

To all whom it may concern:

Be it known that I, SAMUEL C. SPANGLER, a citizen of the United States, and a resident of Clyde, in the county of Grant and Territory of Oklahoma, have invented a new and Improved Friction-Gear, of which the following is a full, clear, and exact description.

This invention relates to a gear by which rotary movement may be transmitted from a single driver to a plurality of driven elements in either direction.

Briefly stated, the apparatus comprises a driving-shaft having two spaced gear-disks fast thereon, the driven element or elements having gears set between the gear-disks and means for moving the gears of the driven elements into engagement with either of the disks, whereby to drive the driven elements in either direction.

The invention is applicable to many purposes, but as here illustrated it is best adapted to my pitching apparatus, which forms the subject of my copending application, Serial No. 80,410, filed October 29, 1901.

This specification is an exact description of one example of my invention, while the claims define the actual scope thereof.

Reference is to be had to the accompanying drawings, forming a part of this specification, in which similar characters of reference indicate corresponding parts in both views.

Figure 1 is a section of the invention on the line 1 1 of Fig. 2, and Fig. 2 is a plan view of the invention.

a indicates a frame, and b indicates the primary movement shaft, which latter is fitted with a gear b' , (see dotted lines, Fig. 2,) in mesh with a gear c on a vertical shaft d . This shaft d is mounted in the frame a and in an overhanging arm e , which is fastened on the frame, as shown.

f and g indicate the friction-gear disks, which are keyed or otherwise fastened on the shaft d and spaced from each other, as shown, the arm e projecting between them.

h indicates the driven elements or shafts, here shown to be three in number. To these

shafts h are connected universal joints h' , which are also connected to short shafts h'' . The short shafts h'' extend between the disks f and g and carry the friction-gears i , which are of such diameter that they may stand out of contact with either gear, as shown in Fig. 1, and through the action of the joints h' these gears i may be engaged with either of the disks f and g , and thus the shafts h may be allowed to rest or be driven in either direction at will. Collars k are arranged loosely on the shafts h'' , and to these collars are fastened boxes k' , fastened to or forming parts of vertical rods k'' . Said rods are held to slide longitudinally in the frame a and are connected at their lower ends to levers k^3 , which are fulcrumed under the shaft d and have links k^4 attached to their other ends.

k^5 indicates hand-levers, which are of elbow form and connected at their short arms to the links k^4 , the long arms standing vertically as handles. Springs k^6 are fastened to the frame a and bear against plane portions k^7 of the levers k^5 at points opposite their fulcra, these springs serving to hold the levers normally in vertical position.

By swinging the levers k^5 as indicated by the dotted lines in Fig. 1 the gears i may be engaged with either gear f and g , as desired, and upon releasing the levers they are thrown back to inactive position by the springs k^6 . It will be observed that this arrangement gives the operator complete control over the various shafts h , allowing them to be turned at will in either direction.

Various changes in the form, proportions, and minor details of my invention may be resorted to without departing from the spirit and scope thereof. Hence I consider myself entitled to all such variations as may lie within the intent of my claims.

Having thus described my invention, I claim as new and desire to secure by Letters Patent—

1. The combination of a revoluble member having two surfaces spaced from each other, a revoluble shaft, a second shaft having universal connection with the first-named shaft,

a gear attached to the second shaft and introduced between the two surfaces of the said revoluble member, a box in which the second-named shaft is revoluble, a rod attached to the
 5 box, a guide in which the rod is reciprocal, and means for actuating the rod, said means comprising a lever connected to one end of the rod, a link connected to the other end of the lever, a hand-lever connected to the link,
 10 said hand-lever being bent and having a plane portion adjacent to its elbow, and a spring member engaging said plane portion, for the purpose specified.

2. The combination with a framing, of an
 15 overhanging arm mounted thereon, connected friction-disks spaced from each other and between which the arm projects, whereby revolubly to mount the disks, means for driving said disks as a unit, a shaft, a second shaft
 20 having universal connection therewith, a friction-wheel attached to the second shaft and located between the friction-disks, a box revolubly connected with the second shaft, a rod mounted to reciprocate in the frame and hav-
 25 ing connection with the box, and means for operating the rod.

3. The combination with a framing, of an
 overhanging arm mounted thereon, connected
 30 friction-disks spaced apart from each other and between which the arm projects, said arm

mounting the axles of the disks to permit the rotation thereof, means for driving said disks as a unit, a friction-wheel seated between the disks, and means for adjustably mounting the
 35 friction-wheel and transmitting the movement thereof, said wheel being capable by its adjustment, of engaging either disk.

4. In a friction-gear, the combination of two disks spaced apart and mounted to turn as a unit, means for driving the disks, a revoluble
 40 shaft, a shaft-section having universal connection with one end of the revoluble shaft and projected essentially longitudinally beyond the shaft, said shaft being capable of swing-
 45 ing around the center of said connection and being projected between the said disks, a friction-wheel attached to the shaft between the disks, for the purpose specified, a collar mounted loosely on the shaft-section, a box
 50 having pivotal connection with the collar, a rod attached to the box, a guide for the rod permitting the same to move longitudinally, and means for so moving the rod.

In testimony whereof I have signed my name to this specification in the presence of two sub-
 55 scribing witnesses.

SAMUEL C. SPANGLER.

Witnesses:

WM. BAIRD,
 J. A. CURTIS.