



(86) **Date de dépôt PCT/PCT Filing Date:** 2014/11/06
 (87) **Date publication PCT/PCT Publication Date:** 2015/05/14
 (85) **Entrée phase nationale/National Entry:** 2016/04/22
 (86) **N° demande PCT/PCT Application No.:** EP 2014/073928
 (87) **N° publication PCT/PCT Publication No.:** 2015/067693
 (30) **Priorité/Priority:** 2013/11/08 (DE10 2013 222 694.2)

(51) **Cl.Int./Int.Cl. B65G 21/06** (2006.01),
G01G 21/23 (2006.01)
 (71) **Demandeur/Applicant:**
GEA FOOD SOLUTIONS GERMANY GMBH, DE
 (72) **Inventeur/Inventor:**
GAHLER, THOMAS, DE
 (74) **Agent:** FETHERSTONHAUGH & CO.

(54) **Titre : BALANCE MUNIE D'UN PLATEAU DE PESAGE RABATTABLE**
 (54) **Title: SCALES WITH A FOLDABLE WEIGHING TABLE**

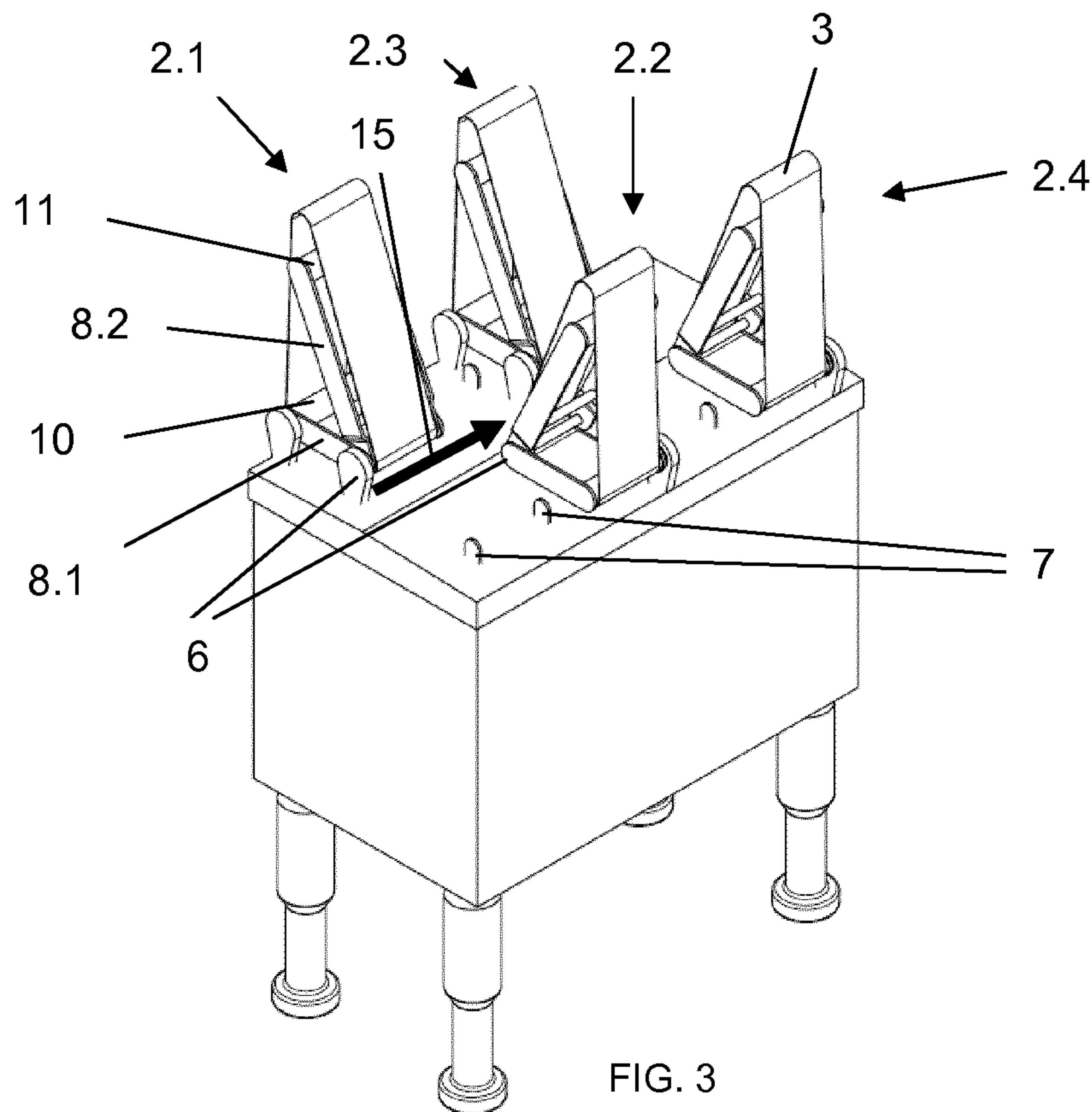

FIG. 3

(57) **Abrégé/Abstract:**

The invention relates to some scales comprising a frame on which at least one, preferably several weighing tables which are respectively provided with a frame, are arranged.

Abstract

The invention relates to some scales comprising a frame on which at least one, preferably several weighing tables which are respectively provided with a frame, are arranged.

Scales with a foldable weighing table

The present invention relates to a set of scales having
5 a rack on which at least one, preferably a plurality of
weighing tables which is/are in each case provided with
a frame is/are provided.

Sets of scales of this type are well known from the
10 prior art, for example from DE 2 356 671. It is also
known for sets of scales having a plurality of weighing
tables to be provided downstream of multi-track slicing
devices, for example, wherein preferably one weighing
15 table is then assigned to each track of the slicing
device. However, these weighing tables may be cleaned
only with comparative complexity, so that cleaning is
rarely and/or insufficiently performed.

It was thus the object of the present invention to
20 provide a set of scales which does not have the
disadvantages of the prior art.

The object is achieved by a set of scales having a rack
on which at least one, preferably a plurality of
25 weighing tables is/are provided which has/have in each
case one frame, wherein the frame of at least one
weighing table is provided so as to be at least
partially pivotable and/or rotatable in relation to the
rack, such that the frame is convertible from a use
30 position to a cleaning position and vice-versa.

The present invention relates to a set of scales, in
particular for foodstuffs, in particular for sliced
foodstuffs, which preferably contain protein. The
35 foodstuffs are in particular sausage, cheese, or ham.
The set of scales has a rack on which at least one,
typically a plurality of weighing tables is/are
disposed. The weighing tables are preferably disposed
so as to be mutually parallel. The number of the

weighing tables preferably corresponds to at least the number of tracks of a foodstuff processing device, in particular a slicing device, that is provided upstream. Each weighing table may determine the weight of the product, for example of the foodstuff portion which is composed of one or a plurality of foodstuff slices, in a manner independent of the other weighing tables. Determining the weight typically is performed while the product is moving in relation to the respective weighing table. Each weighing table has one frame. According to the invention, the frame of at least one weighing table is provided so as to be now partially pivotable and/or rotatable in relation to the rack, such that the frame is convertible from a use position to a cleaning position and vice-versa. In the use position, the surface of the weighing table on which the product to be weighed is located is preferably oriented so as to be horizontal and is particularly preferably aligned with conveying means which are located upstream and/or downstream of the weighing table. At least one measuring cell which interacts directly or indirectly with the weighing table, in particular with the pivotable and/or rotatable part of the weighing table and, on account thereof, determines the weight of the product which is located on the weighing table is preferably located in the region of each weighing table. In the cleaning position the pivotable and/or rotatable part of the frame is then located in a position which is angular, preferably rectangular in relation to the horizontal. In the cleaning position both the weighing table as well as the rack of the set of scales are readily accessible and, on account thereof, very easy to clean. In the cleaning position of the frame an endless belt which is optionally provided on the frame of the weighing table may be removed from said frame and cleaned.

Preferably, the frame in relation to the rack of the set of scales has a fixed portion and a pivotable and/or rotatable portion. The two portions are preferably interconnected by way of a rotating and/or pivoting mounting, such that the rotatable and/or pivotable portion may be moved in relation to the fixed portion. This rotating and/or pivoting mounting may be connected to the rack of the set of scales. Both portions have a length which in each case is the extent of the former in the conveying direction. Preferably, the pivotable portion has a greater length than the fixed portion.

Preferably, a spacing in a manner transverse to the conveying direction of the conveyor belts, in particular of the endless belts, is provided between two adjacent frames. Preferably, the fixed portions of two opposite, in particular offset, frames are provided such that a continuous spacing is provided between the mutually facing ends of said fixed portions. One or more spacings may serve for cleaning the device and/or for removing the conveyor belts.

Preferably, the weighing table is provided such that the former may completely and/or partially be reversibly removed from the rack of the set of scales.

According to one preferred embodiment of the present invention, the frame of each weighing table is mounted in particular on the rack of the set of scales by way of one mounting or a plurality of mountings. At least one, preferably each, mounting here may be provided so as to be releasable from the rack. This mounting interacts or these mountings interact, preferably, with one or a plurality of measuring cells.

For the case in which a plurality of weighing tables are provided and these are particularly preferably

provided so as to be mutually parallel, the mountings of adjacent weighing tables are preferably disposed so as to be mutually offset. This likewise improves/simplifies cleaning of the set of scales according to the invention for example.

Preferably, the pivoting and/or rotating directions of adjacent weighing tables from the use position to the cleaning position and vice-versa are in each case opposed. This preferred embodiment of the present invention also improves/simplifies cleaning of the set of scales according to the invention. Moreover, assembly/disassembly of a conveying means, in particular of a conveyor belt, which is optionally disposed on the frame is simplified by this preferred embodiment of the present invention.

According to one preferred embodiment of the present invention, a conveying means, in particular a conveyor belt, preferably an endless belt, is disposed on the frame. This conveying means is preferably driven and moves the product to be weighed along the weighing table. The weight of the product is preferably determined during the dwelling time of the product on the weighing table. Endless tapes of which preferably a plurality are provided per weighing table so as to be mutually parallel are also coming as a preferred conveying means.

Preferably, the frame in the use position thereof tensions the conveying means, in particular the conveyor belt. In the cleaning position of the frame the conveying means is preferably not tensioned and, on account thereof, may be readily removed from the frame, for example in order for the latter to be repaired, replaced, or cleaned.

Preferably, the frame at two sides which in relation to the running direction of the conveying means are mutually opposite has in each case one roller around which the conveying means, in particular the endless
5 belt or the endless tape/tapes revolve. One of the rollers is preferably driven, wherein the drive motor is preferably located within the rack of the set of scales.

10 Preferably, the pivotable and/or rotatable portion of the frame in the use and/or cleaning position thereof is lockable, in particular without the use of tools, to the fixed portion of the frame or in relation to the rack.

15 A further subject matter of the present invention is a line for producing foodstuff, in particular sliced foodstuff portions, having the set of scales according to the invention.

20 Preferably, the line upstream of the set of scales has a slicing device by way of which a foodstuff block is sliced into foodstuff slices.

25 An insertion unit which inserts the weighed products into an item of packaging is preferably provided downstream of the set of scales.

30 The signal from the set of scales is preferably used for controlling the slicing device.

The invention will be explained hereunder by means of
35 figs. 1 to 3. These explanations are merely exemplary and do not limit the general concept of the invention.

Fig. 1 shows the set of scales according to the invention, having the weighing tables in the use position.

Fig. 2 shows a lateral view of the set of scales according to the invention, according to fig. 1.

5

Fig. 3 shows the set of scales according to figs. 1 and 2, having the weighing tables in the cleaning position.

10 **Fig. 1** shows the set of scales 1 according to the invention, which has a rack 4, having a frame which is surrounded by a casing. Drives and/or the electronics of the set of scales may be located within the rack. The set of scales in the present case furthermore has
15 four weighing tables 2 along which the product to be weighed, presently sliced foodstuffs, is conveyed and thereby weighed, as is illustrated by the arrow 12. Each weighing table can weigh in a manner completely independent of the other weighing tables, and the
20 weight weighed in each case may be determined in a manner independent of the other weighing tables and be utilized for controlling the upstream slicing device and/or a downstream product separating unit and/or product completion unit. Each weighing table 2.1 - 2.4
25 is mounted on the rack by way of at least one mounting, presently two mountings 5, 6. The mountings 5, 6 of two adjacent weighing tables are preferably disposed so as to be mutually offset. In the present case, the mounting 5, 6 of a weighing table 2.1, 2.3 is located
30 at the one end of the rack of the set of scales, and the mounting 5, 6 of the respectively adjacent weighing table 2.2, 2.4 is located at the opposite end of the weighing table. Each weighing table 2 has a frame 8 which in the present case at two mutually opposite ends
35 is provided with in each case one roller 10, 11, of which here the roller 10 is driven (cf. fig. 3). In order for the product to be weighed in each case to be conveyed along the weighing table and to be thereby

weighed, a conveying means 3, presently an endless belt, revolves around the rollers 10, 11. The conveying means 3 is rotatably driven by the roller 10. In order for the product which is in each case located on the weighing table to be weighed, one or a plurality of measuring cells which interacts or interact, respectively, with the respective weighing table is/are provided. The measuring cell is preferably not part of the frame. One support 7 is preferably provided for the pivotable part of each frame.

Fig. 2 shows a lateral view of the set of scales 1 according to fig. 1. It can be clearly seen that the frame 8 of each weighing table is composed of a portion 8.1 which is fixed in relation to the rack 4 and in the present case is provided on the rack by means of the mountings 5, 6, and of a pivotable and/or rotatable portion 8.2. The portion 8.2 is mounted on the portion 8.1 by means of the pivot and/or rotation axis 9 on the portion 8.1 and/or on the rack 4. In the present case, the pivotable and/or rotatable portion 8.2 interacts with the measuring cell. It can be clearly seen that according to one preferred embodiment, the length 13 of the pivotable portion is longer than the length 14 of the fixed portion. The length here is in each case the extent of the respective portion in the conveying direction of the product. The mountings 5 and/or 6 are preferably connected directly or indirectly to the measuring cell.

Both figs. 1 and 2 in each case show the set of scales 1 having the weighing tables in the use position, that is to say in the position in which the weight of a product may be determined on each weighing table.

The set of scales 1 having all weighing tables 2.1 - 2.4 in the cleaning position is illustrated in **fig. 3**. In this case, the pivotable and/or rotatable regions

8.2 are swiveled from the substantially horizontal use position of the former by a specific angle, presently at least 90°, about the axis 9 in relation to the fixed portion 8.1. However, the angle is preferably more than
5 90°, in order to ensure that the pivotable region remains in this position. On account thereof, the conveyor strap 4 is relaxed and may be removed from the frame 8 of the respective weighing table. The offset mounting 5, 6 of the respective weighing tables has the
10 advantage that each weighing table 2.1 - 2.4 is readily accessible both from the right as well as from the left side thereof, so that the frames 8 and the rack 4 may be well cleaned and/or the conveyor belt 3 may be readily removed from the frame or be fastened thereto
15 again, respectively. It can also be derived from the illustration according to fig. 3 that the mounting 5, 6 is located on only one side of the frame 8. The conveyor strap may then be removed or assembled, respectively, by way of the opposite side. As soon as
20 cleaning has been completed, the portions 8.2 are in each case converted from the cleaning position to the use position again, and the set of scales 1 is again ready for use. As can likewise be derived from fig. 3, a continuous spacing which facilitates cleaning of the
25 device, for example, is provided between the mutually facing ends, in particular between the mountings 6 of two mutually opposite frames. A spacing between the fixed portions is preferably also provided in a manner transverse to the conveying direction of the conveyor
30 belts, so as to be able to readily remove the conveyor belts from the frame.

List of reference signs:

- | | | |
|----|-----------|---|
| | 1 | Set of scales, multi-track scales |
| | 2 | Weighing table |
| 5 | 2.1 - 2.4 | First to fourth weighing table |
| | 3 | Conveyor belt, endless belt |
| | 4 | Rack |
| | 5 | First mounting |
| | 6 | Second mounting |
| 10 | 7 | Support of pivotable portion |
| | 8 | Frame of weighing table |
| | 8.1 | Fixed portion |
| | 8.2 | Pivotable portion |
| | 9 | Pivot and/or rotation axis |
| 15 | 10 | Driven roller |
| | 11 | Freewheeling roller |
| | 12 | Conveying direction of the products to be weighed |
| | 13 | Length of the pivotable portion |
| 20 | 14 | Length of the fixed portion |
| | 15 | Passage between fixed portions 8.1 |

Patent claims:

- 5
1. A set of scales (1) having a rack (4) on which a plurality of weighing tables (2) are provided which have in each case one frame (8), wherein the frame of each weighing table is provided so as to
- 10 be at least partially pivotable and/or rotatable in relation to the rack (4), such that the frame is convertible from a use position to a cleaning position and vice-versa, and the frame (8) of each weighing table (2) is mounted on the rack by way
- 15 of a mounting (5, 6), characterized in that the mountings (5, 6) of adjacent weighing tables (2) are disposed so as to be mutually offset.
2. The set of scales (1) as claimed in claim 1,
- 20 characterized in that the frame (8) in relation to the rack (4) has a fixed portion (8.1) and a pivotable and/or rotatable portion (8.2).
3. The set of scales (1) as claimed in one of the
- 25 preceding claims, that the pivoting and/or rotating directions of adjacent weighing tables from the use position to the cleaning position and vice-versa are in each case opposed.
- 30 4. The set of scales (1) as claimed in one of the preceding claims, characterized in that a conveying means (3), in particular an endless belt, is disposed on the frame.
- 35 5. The set of scales (1) as claimed in claim 4, characterized in that the frame in the use position thereof tensions the conveyor belt (3), and that said conveyor belt (3) in the cleaning position of the frame is not tensioned.

AMENDED SHEET

6. The set of scales (1) as claimed in claim 5, characterized in that the conveyor belt (3) in the non-tensioned state is removable from the frame.
- 5
7. The set of scales (1) as claimed in one of the preceding claims, characterized in that the conveyor belt at two ends (3.1, 3.2) which in relation to the running direction of the former are mutually opposite has in each case one roller.
- 10
8. The set of scales as claimed in one of the preceding claims, characterized in that the frame (8) is provided so as to be partially removable.

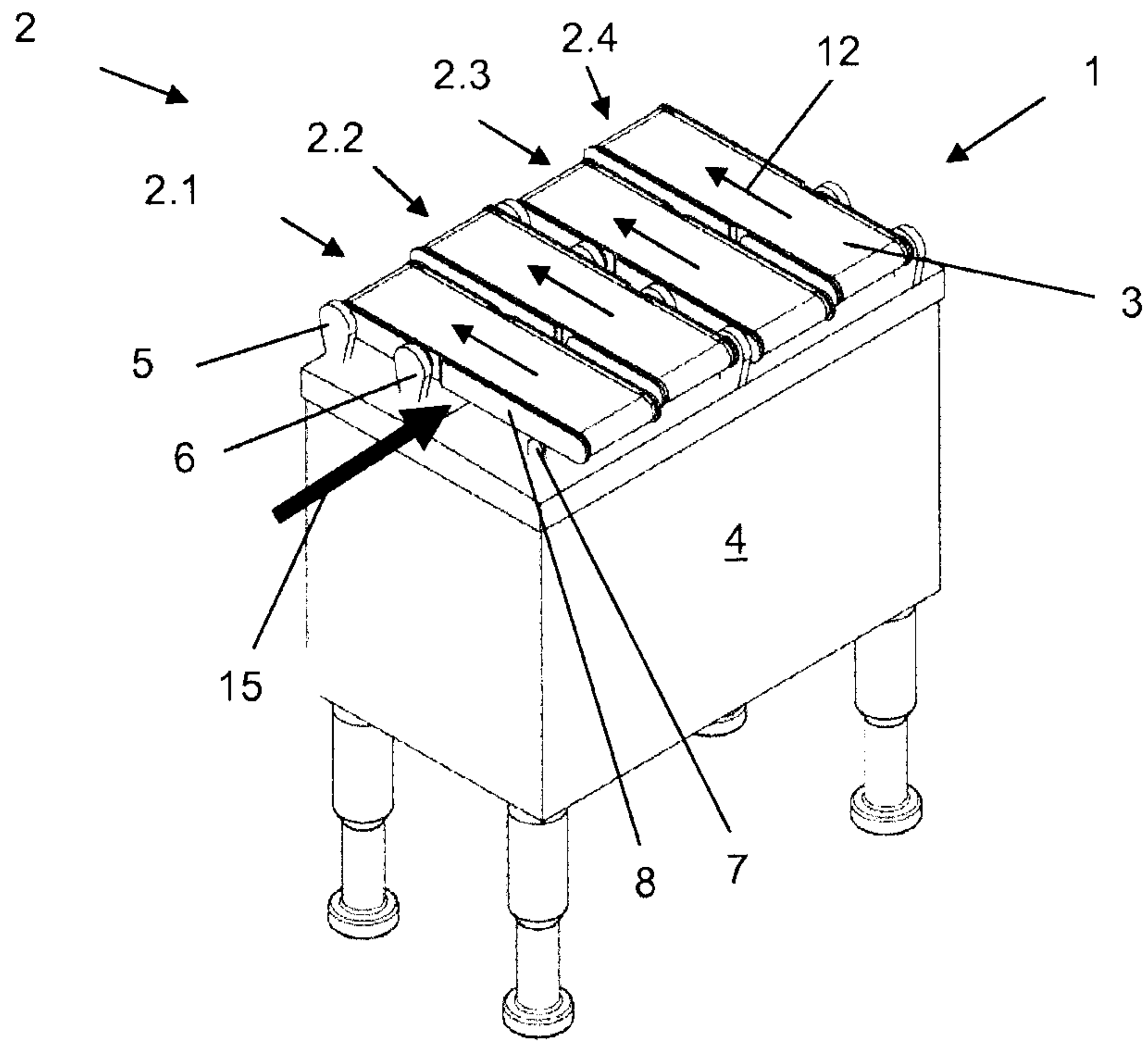

FIG. 1

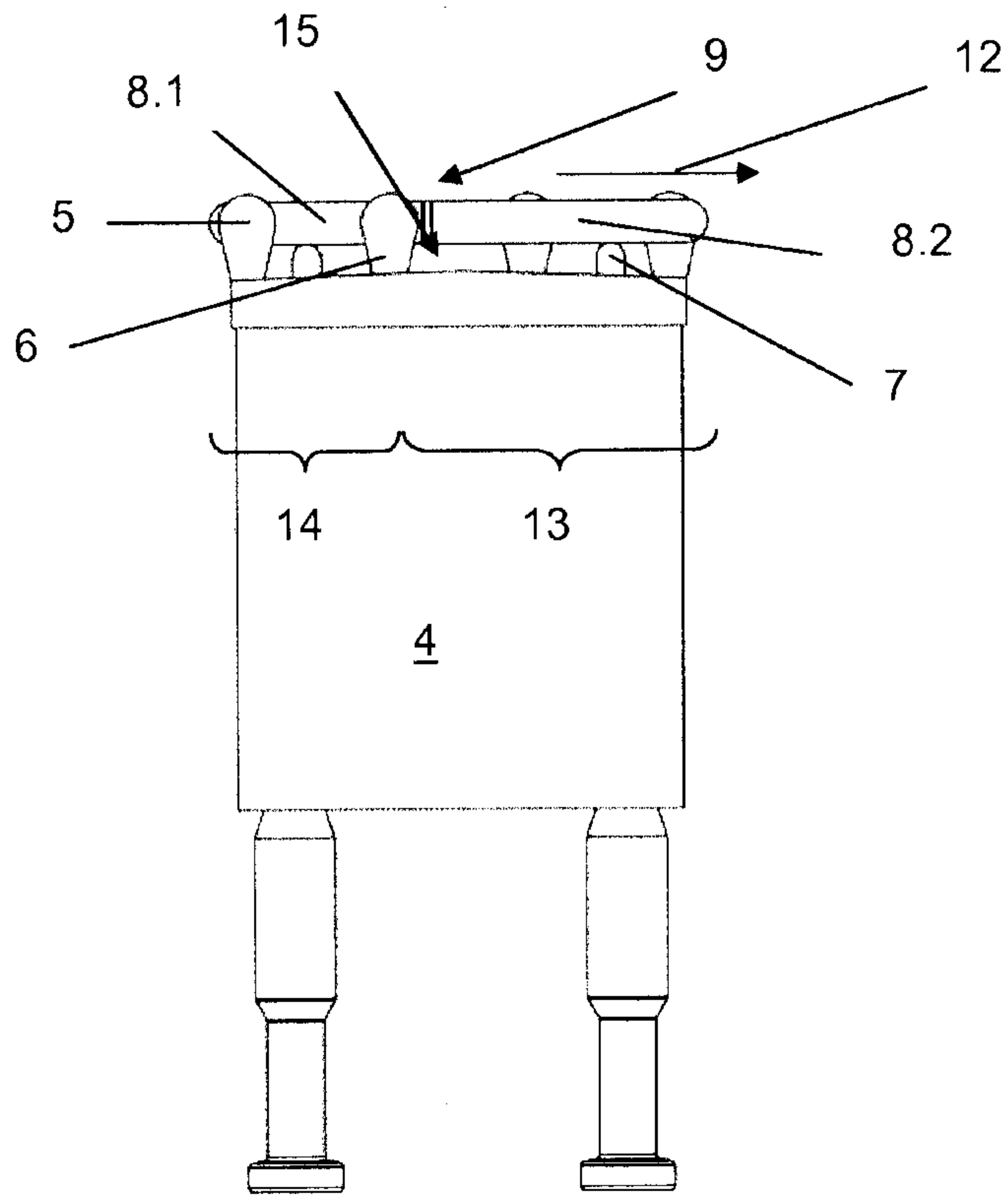

FIG. 2

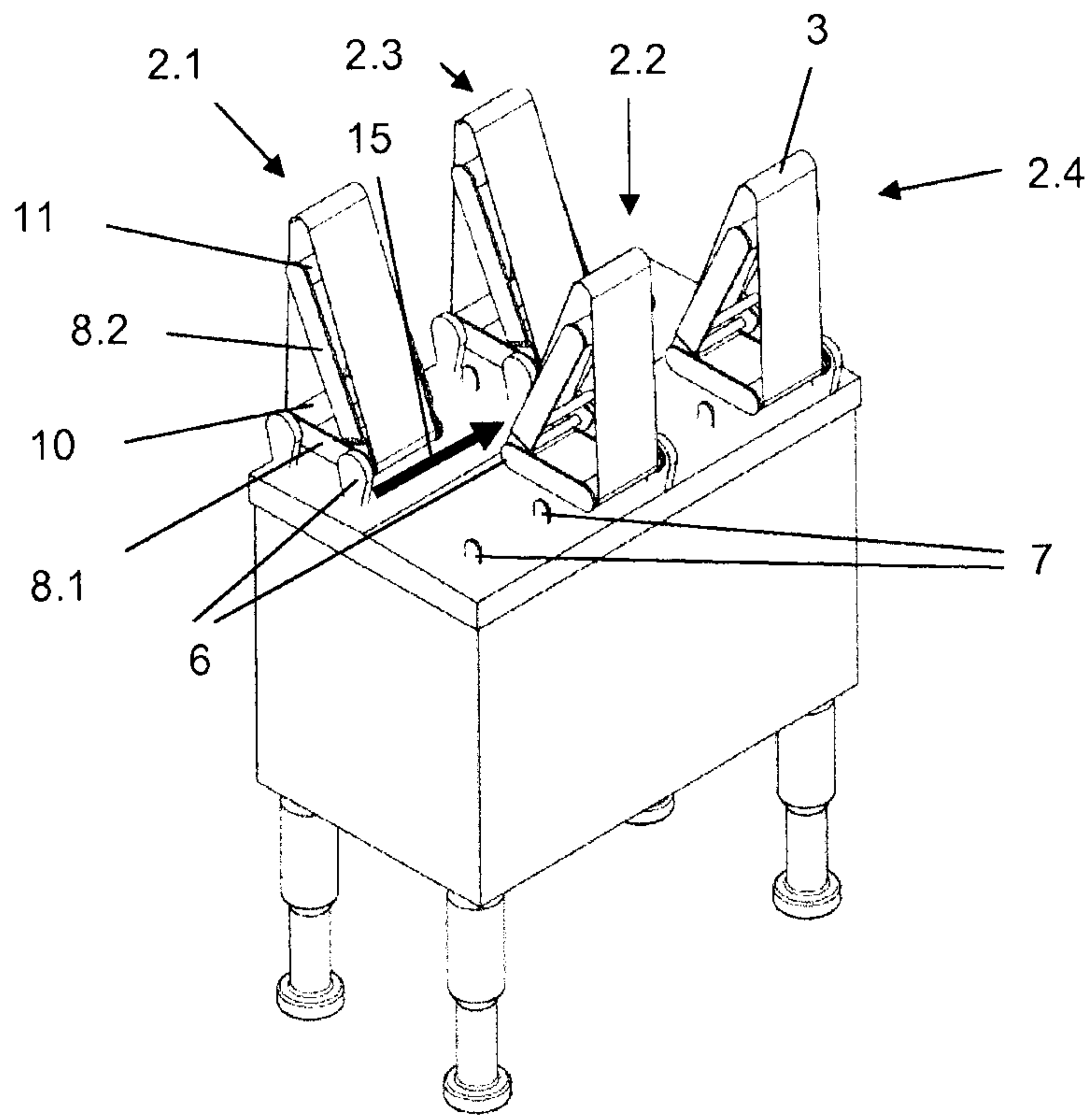

FIG. 3

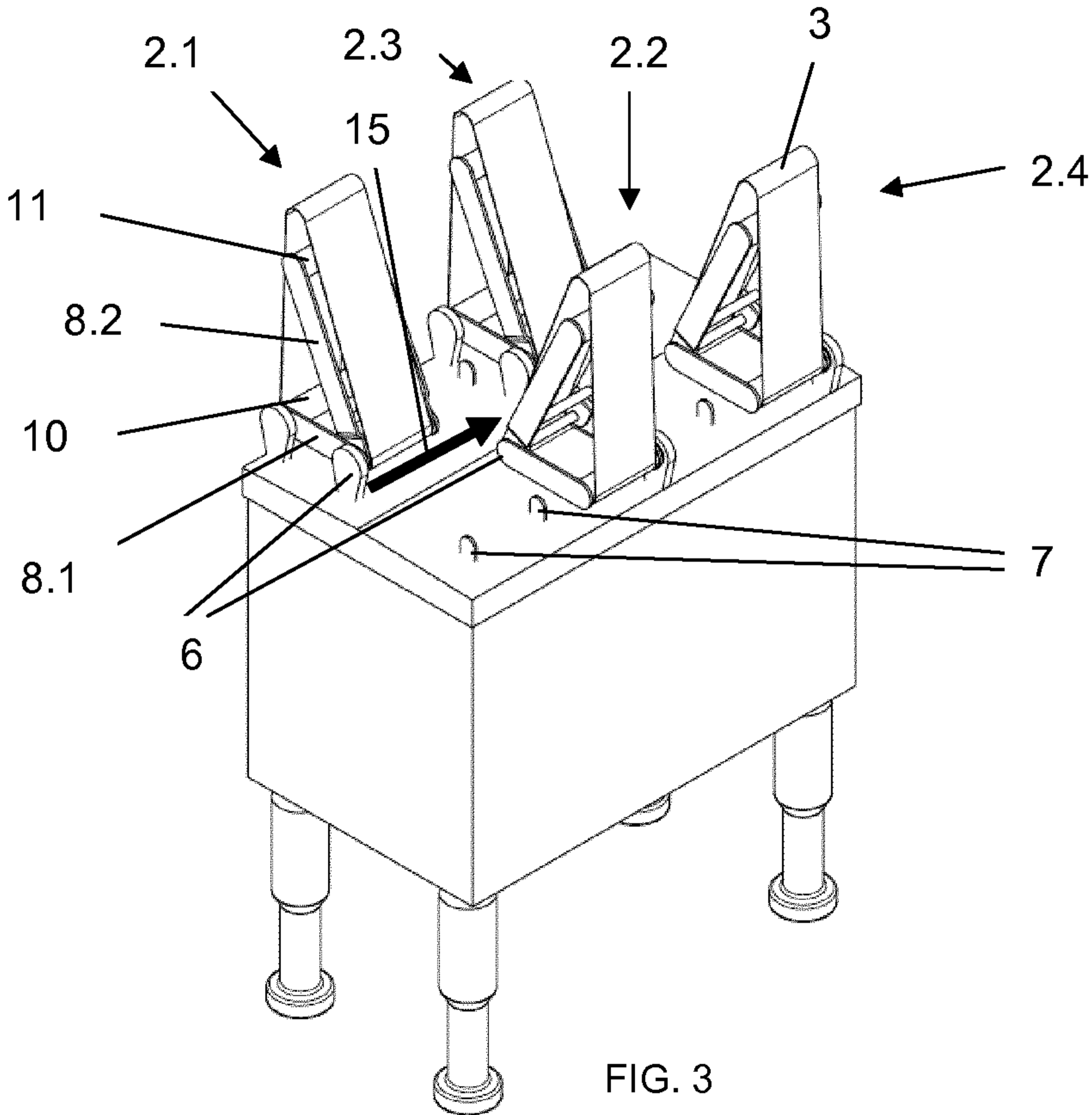

FIG. 3