

No. 693,773.

Patented Feb. 18, 1902.

A. F. BARDWELL.
CARBURETER FOR EXPLOSIVE ENGINES.

(Application filed Oct. 20, 1900.)

(No Model.)

2 Sheets—Sheet 1.

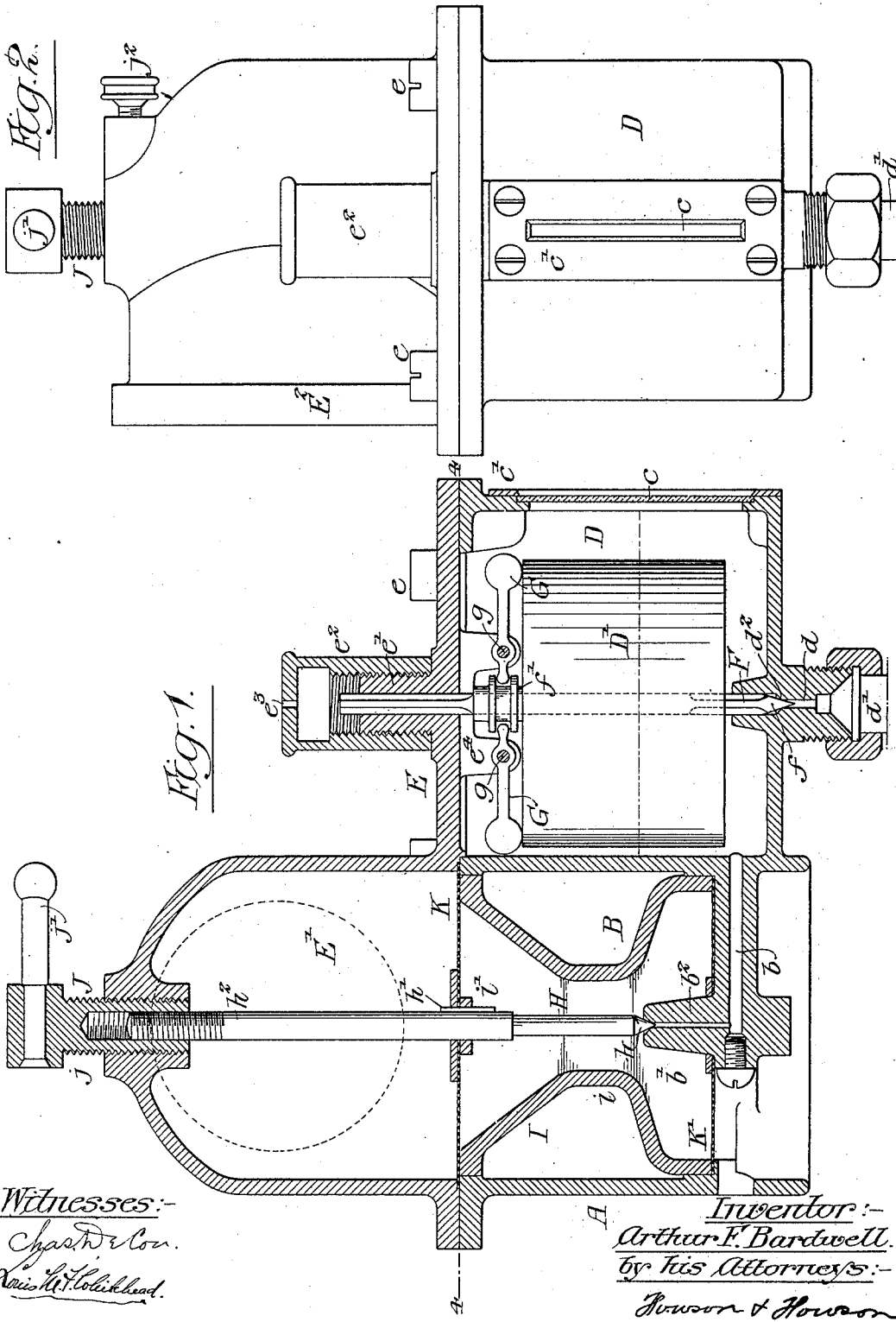

Witnesses:-
Chas. D. Coe.
Wm. H. Holshhead.

Inventor:-
Arthur F. Bardwell.
by his Attorneys:-
Howson & Howson

A. F. BARDWELL.
CARBURETER FOR EXPLOSIVE ENGINES.

(Application filed Oct. 20, 1900.)

(No Model.)

2 Sheets—Sheet 2.

Fig. 3.

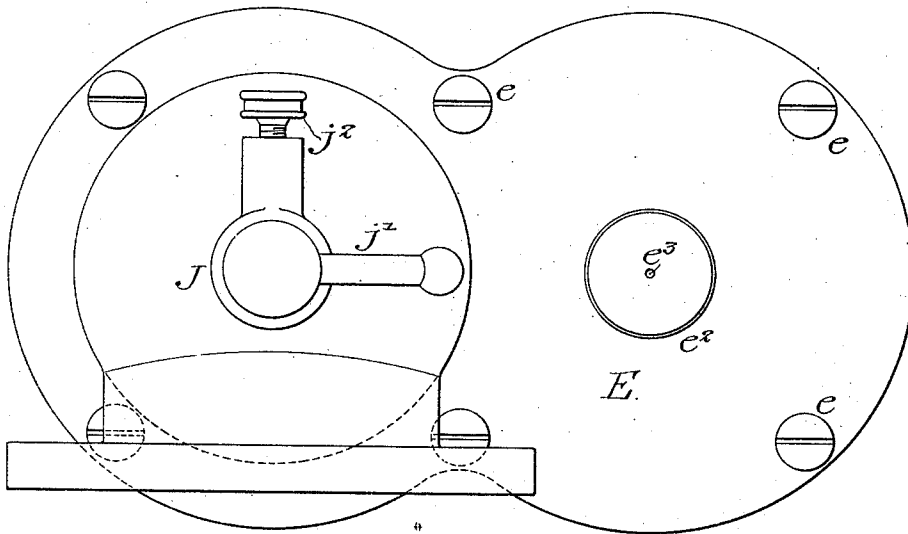
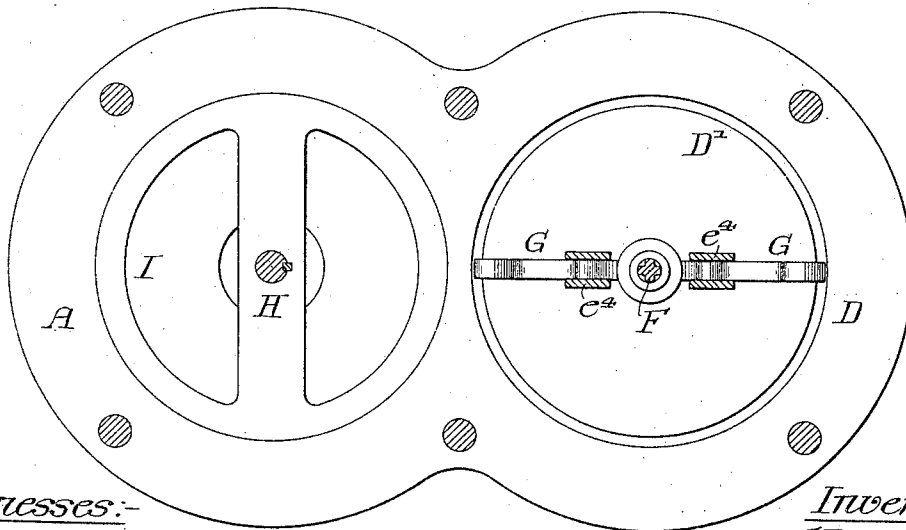

Fig. 4.



Witnesses:-

Chas. Wilson.
Wm. H. Holbrook.

Inventor:

Arthur F. Bardwell.
by his Attorneys:-
Hornum & Hornum

UNITED STATES PATENT OFFICE.

ARTHUR F. BARDWELL, OF MOUNT VERNON, NEW YORK, ASSIGNOR TO THE DAIMLER MANUFACTURING COMPANY, OF LONG ISLAND CITY, NEW YORK, A CORPORATION OF NEW YORK.

CARBURETER FOR EXPLOSIVE-ENGINES.

SPECIFICATION forming part of Letters Patent No. 693,773, dated February 18, 1902.

Application filed October 20, 1900. Serial No. 33,716. (No model.)

To all whom it may concern:

Be it known that I, ARTHUR F. BARDWELL, a citizen of the United States, and a resident of Mount Vernon, New York, have invented certain Improvements in Carbureters, of which the following is a specification.

The object of my invention is to construct a simple and effective carbureter for use in connection with gasolene-engines. This object I attain in the following manner, reference being had to the accompanying drawings, in which—

Figure 1 is a longitudinal sectional view of my improved carbureter. Fig. 2 is a side view. Fig. 3 is a plan view; and Fig. 4 is a section on the line 4 4, Fig. 1.

A is the casing of the carbureter, having two chambers B and D. This casing is made in a single casting, and secured to the casing is a cap-plate E, having the gas-chamber E'. The cap-plate is secured to the casing by bolts e.

The chamber D is the receiving-chamber for the gasolene, and the chamber B is the carbureting-chamber proper.

d is the inlet for the gasolene. The inlet is formed in a boss projecting from the under side of the casing A and a pipe leading from the gasolene-tank is coupled to this boss in any suitable manner, in the present instance by means of a screw-coupling.

F is a needle-valve, having a tapered point f, which can be seated at d² in the inlet-passage d. This needle-valve extends through the chamber D and through an opening in the boss e' on the cap E.

The needle-valve F is grooved longitudinally directly above its conical point f and at the point where it finds its upper bearing in the boss e'. The valve is so formed that when it is raised off its seat d² gasolene will be admitted to the chamber D and entrapped air will escape through the upper channels. A threaded cap is screwed onto the boss e' and has an air-vent e³. The cap prevents the overflow of gasolene should the chamber D become flooded and also acts to protect the valve-stem.

To regulate the flow of gasolene into the

chamber D, I provide a float D', mounted within the chamber and arranged to slide upon and be guided by the needle-valve F.

Pivoted at g g to a bracket e⁴, projecting from the under side of the cap E, are levers G. The short arms of these levers engage a collar f', secured to the needle-valve F, and the long arms of the levers are preferably enlarged or weighted and rest upon the upper end of the float D', so that when gasolene is admitted to the chamber D and under slight pressure the float is elevated, causing the long arms of the levers to be raised, the sleeve f' and the valve-rod F will be forced down toward the seat d², and in time the valve will be closed. As soon as the gasolene recedes the float D falls and the weighted levers G elevate the valve F and cause it to move off its seat, allowing gasolene to enter through the inlet-passage d. The air-vent e³ is also important, as it not only allows for the escape of entrapped air, but also, if the gasolene should form gas by excessive outward heat, the gas can blow off through this opening, and by providing this opening the gas can flow freely into and out of the chamber and maintain a uniform level.

In the carbureting-chamber B is situated a detachable bushing I. This bushing has a contracted neck i, and is flanged at each end to fit the casing, as clearly shown in Fig. 1. The neck of the bushing varies according to the size of the engine to which the carbureter is attached, as it controls the flow of air through the carbureter.

b is an outlet-passage leading from the chamber D to the nozzle b', having a passage b² at right angles to the passage b in the present instance. This nozzle extends up to a point directly below the contracted neck of the bushing I and has a flared opening, forming a valve-seat for the needle-valve H, having a needle-point h.

In the present instance the angle of the valve-seat is about ninety degrees, while the angle of the needle-valve is considerably less. By this arrangement the gasolene is allowed to flow slightly over the valve-seat; but the flow of gasolene can be entirely cut off by ad-

justing the valve H. This valve has a key h' , arranged to slide in a keyway in the cross-bar i' of the bushing I, and the upper end h^2 of the valve-rod H is screw-threaded, and onto the threaded end is screwed a nut J, having external threads j , which mesh with threads in the projecting portion E' of the cap. In the present instance one of the threads is cut forty to the inch and the other forty-two. This enables the operator to adjust the needle-valve to a microscopic degree by simply turning the lever j' of the nut J in one direction or the other. The nut J is held in the adjusted position in the present instance by a set-screw j^2 . (Shown in the plan view, Fig. 3.) In some instances the valve-rod H may be secured directly to the nut J when the microscopic adjustment is not desired.

Directly above the bushing I is a screen K, which is used for the purpose of thoroughly mixing the vaporized gasolene. A screen K' is used at the bottom of the bushing for the purpose of preventing foreign matter entering the carbureter and may be omitted in some instances.

The pipe leading to the gas-engine is coupled to the neck E^2 , projecting from one side of the chamber E' .

In the side of the chamber D is a gage-glass c , which can be secured in any suitable manner, and in the present instance is fastened in position by a plate c' , so that the height of gasolene in the reservoir D will readily show through the glass.

The operation of my improved carbureter is as follows: It is coupled to the gasolene engine or motor and upon every stroke of the piston a certain amount of atmospheric air is collected in the cylinder, and this inrushing air is contracted by the throat of the bushing to such a density as to form a violent inrush at this point and will take up the proper quantity of gasolene which is allowed to overflow through the outlet-passage b^2 , which communicates with the chamber D, the amount of overflow being regulated by the needle-valve H. The form of adjustment used allows for the mixing of the air and gasolene in the right proportions.

I claim as my invention—

1. The combination in a carbureter, of a single casting having two chambers therein,

one a gasolene-chamber, the other a carbureting-chamber, a passage forming communication between the two, a detachable bushing in the carbureting-chamber having a contracted neck, a cap-plate covering both chambers, a valve-stem carried by the cap-plate and controlling the flow of gasolene to the carbureter-chamber, and an automatic valve in the gasolene-chamber guided by the casing and the cap-plate, substantially as described.

2. The combination of a casing divided into two chambers, one a gasolene-receiving chamber, the other a carbureting-chamber, a passage forming communication between the gasolene-chamber and the carbureting-chamber, a detachable bushing having a contracted neck and flared at its upper end, a valve-seat at the lower portion of the neck, a cap-plate, a screw-valve carried by the cap-plate and guided by the bushing, said valve being arranged to rest upon said seat and controlling the flow of liquid from the gasolene-chamber to the carbureting-chamber, substantially as described.

3. The combination of a carbureter, a casing having two chambers, one a gasolene-receiving chamber, the other a carbureting-chamber, an inlet-opening in the bottom of the gasolene-chamber, a cap-plate covering both of said chambers, a valve to control the flow of liquid in the gasolene-chamber, said valve being guided at its lower end in the casing and at the upper end in the cap-plate, a float, levers pivoted to the cap-plate and engaging the stem of the valve, said levers being controlled by the float, a bushing having a reduced neck, a passage forming communication between the gasolene-chamber and the carbureting-chamber, said passage ending at the lower portion of the neck in the said bushing, a valve carried by the cap-plate and arranged to control the passage of fluid through said passage into the carbureter, substantially as described.

In testimony whereof I have signed my name to this specification in the presence of two subscribing witnesses.

ARTHUR F. BARDWELL.

Witnesses:

CHAS. W. MOFFETT,
ALBERT GRAFF.