

No. 608,438.

Patented Aug. 2, 1898.

O. I. BYE.
MUSIC HOLDER.

(Application filed Sept. 22, 1897.)

(No Model.)

Fig. 1.

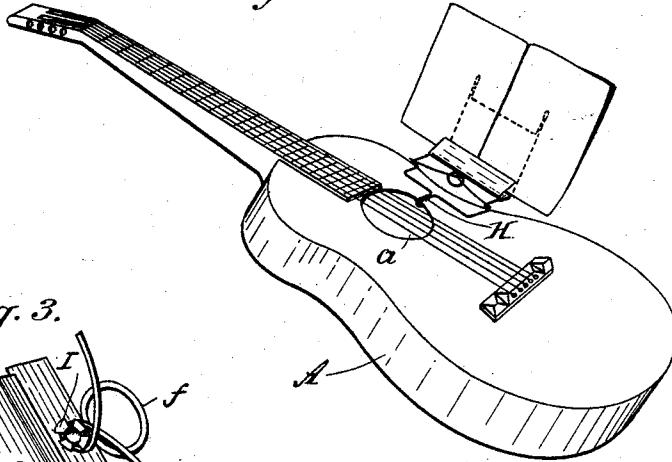

Fig. 3.

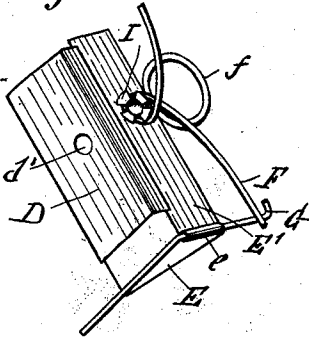
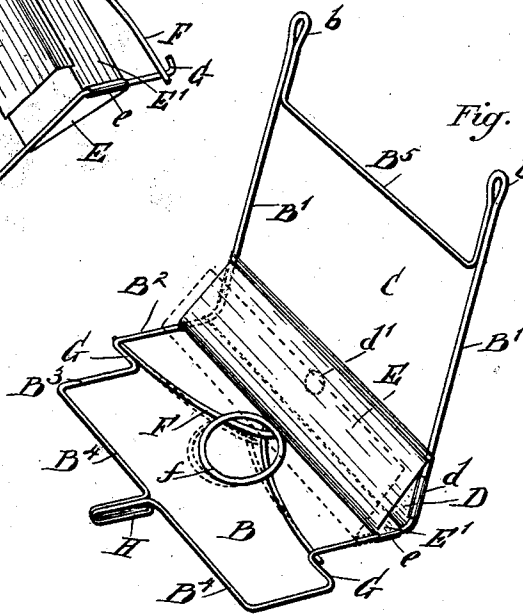

Fig. 2.



WITNESSES:

Otto Spieth.
H. L. Reynolds.

INVENTOR

O. I. Bye.

BY

Mummy

ATTORNEYS.

UNITED STATES PATENT OFFICE.

OLAVES I. BYE, OF HILLSBOROUGH, NORTH DAKOTA.

MUSIC-HOLDER.

SPECIFICATION forming part of Letters Patent No. 608,438, dated August 2, 1898.

Application filed September 22, 1897. Serial No. 652,508. (No model.)

To all whom it may concern:

Be it known that I, OLAVES I. BYE, of Hillsborough, in the county of Traill and State of North Dakota, have invented a new and Improved Music-Holder, of which the following is a full, clear, and exact description.

My invention relates to a music-leaf holder especially adapted to be used in connection with guitars and similar instruments; and it consists of a frame constructed, preferably, of wire or light metal and provided with a spring-held slide adapted to clamp and hold the music and with a hook which may be placed within the sound-port usually provided in the upper surface of such instruments.

Reference is to be had to the accompanying drawings, forming a part of this specification, in which similar characters of reference indicate corresponding parts in all the views.

Figure 1 is a perspective view of my device as applied to a guitar. Fig. 2 is a perspective view of the device alone, and Fig. 3 is a bottom perspective view showing the manner of attaching a spring to the slide and also showing the aperture in the back of the slide.

The object of my invention is to provide a simple and cheap music-holder which may be attached directly to the instrument, so as to hold the music at all times in clear view of the performer, whether he remains stationary or is moving about; and to this end I have constructed the music-holder as shown in the drawings.

The music-holder is preferably constructed with a framework of wire bent into the form required, and consists of two principal divisions—the back portion C, composed of the vertical wires B', which at the point *b* are bent back upon themselves and connected by the horizontal portion B⁵, and the base portion B, consisting of the horizontal portions B² and B³, which are connected by the rearward bend or offset portion G, the outer portions B³ being connected by the portions B⁴, which are at right angles thereto. At the point where the two parts B⁴ meet they are bent at right angles away from the back and then recurved upon themselves to form a hook H, by which the back is secured to the edge of the sound-port.

The lower portions of the wires B', forming

the back of the holder, are united by a metal plate D, which is secured thereto by having the ends formed into eyes *d*, which are closed about the wire. The portions B² of the base have a slide E, which consists of a thin plate secured thereto by eyes *e*, which are, however, loose enough to permit the same to slide easily upon the wire. This plate E is formed in two portions, the portion E' being horizontal and having the eyes *e* at each end thereof. The main portion E is bent up from the horizontal portion E' and backward, so as to lie at an angle with the back of the holder. The upper edge of the main portion E should be made about even with the upper edge of the plate D.

To the base E' of the plate or slide E is secured a spring F, formed of a wire provided with one or more coils at its center, which coils are secured to the base by means of an eyelet or rivet L. The ends of the spring F engage the hook formed by the backwardly-bent portion or recess G of the wires, forming the base portion B.

To the edge of the plate or slide E, at the center, is secured a ring *f*, which may be engaged by the thumb or finger to draw the slide away from the back C. The position of the slide when so drawn back is shown by dotted lines in Fig. 2. In this position the book or sheet of music may be inserted between the slide E and the back C. When the slide is released, the spring will hold the slide against the music, firmly securing it in place.

The plate D may be provided with an aperture *d'*, by means of which the device may be fastened upon a nail or pin, if desired.

In using this device the hook H is placed over the edge of the sound-port *a* of a guitar, mandolin, or any similar instrument which has a sound-port in its upper surface. The hook H need not grasp the edge of the port so as to hold the device fixedly in one position. The weight of the device will hold it in position, and it may be permitted to swing slightly, if desired. In any event the music will be held facing the performer, whether he remains stationary or moves about.

This device is very small and cheap in construction and may be readily placed within the case containing the instrument.

Having thus fully described my invention, I claim as new and desire to secure by Letters Patent—

1. A music-holder, having the frame thereof formed of a single wire bent to outline the frame, having back and base sections which are substantially rectangular and at right angles to each other, said wire centrally of the outer side edge of the base-section, or at that side farthest from the back section being bent downward and under to form a hook, a slide mounted upon the side wires of the base-section to slide toward and from the back, and a spring normally holding the slide toward the back.

2. A music-holder made of wire bent to outline a frame having back and base sections substantially at right angles to each other, said wires of the base-section having an offset bend therein, and at the outer side edge or that farthest from the back being bent downward and under to form a hook, a slide mounted upon the base, and a spring engag-

ing said slide and the offset bend in the side wires and serving to clamp the music between said slide and the back, substantially as described.

3. A music-holder made of wire bent to outline a frame having back and base sections substantially at right angles to each other, the side wires of the base-section having an offset bend therein, and at the outer side edge or that farthest from the back being bent downward and under to form a hook, a slide mounted upon the base, and a spring consisting of a wire coiled at its center and secured at its point to the slide and having its ends engaging the offset bend in the said wires, whereby the slide is held against the back section and the music clamped therebetween, substantially as described.

OLAVES I. BYE.

Witnesses:

J. O. KJELSBERG,
P. L. BERVIG.