

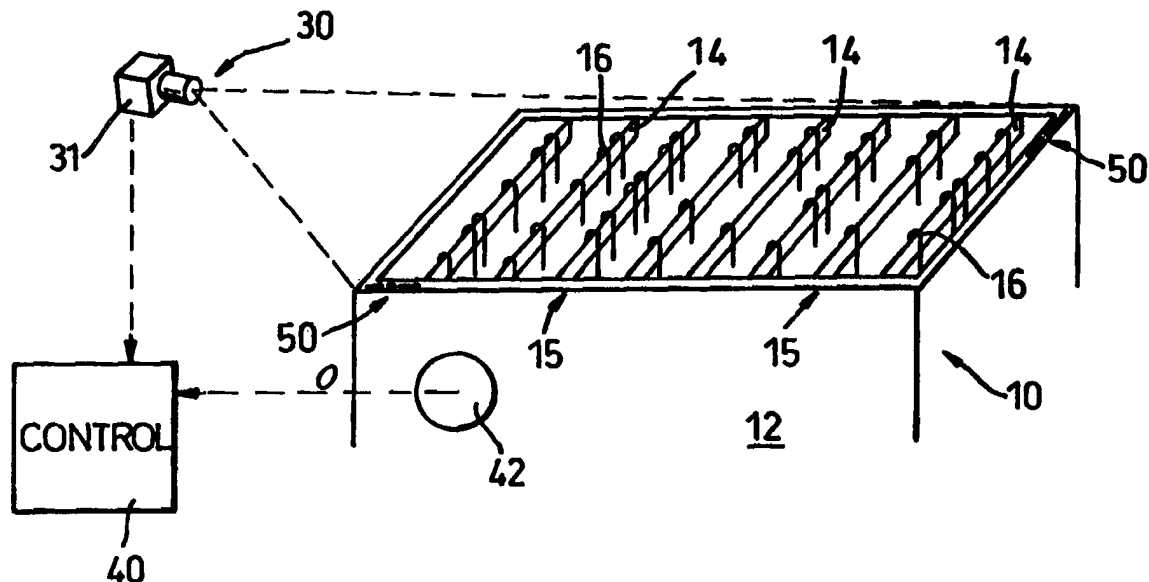

INTERNATIONAL APPLICATION PUBLISHED UNDER THE PATENT COOPERATION TREATY (PCT)

<p>(51) International Patent Classification ⁶ : D03D 51/46, D03C 3/24, 17/06</p>	<p>A1</p>	<p>(11) International Publication Number: WO 98/27254 (43) International Publication Date: 25 June 1998 (25.06.98)</p>
<p>(21) International Application Number: PCT/GB97/03366 (22) International Filing Date: 17 December 1997 (17.12.97) (30) Priority Data: 9626432.0 19 December 1996 (19.12.96) GB (71) Applicants (for all designated States except US): NORTHERN ELECTRONIC TECHNOLOGY LIMITED [GB/GB]; Tedco Business Centre, Viking Industrial Park, Jarrow, Tyne & Wear NE32 3DT (GB). SCAPA GROUP PLC [GB/GB]; Oakfield House, 93 Preston New Road, Blackburn, Lancashire BB2 6AY (GB). (72) Inventors; and (75) Inventors/Applicants (for US only): CROUCHER, Ewan [GB/GB]; Northern Electronic Technology Limited, Tedco Business Centre, Viking Industrial Park, Jarrow, Tyne & Wear NE32 3DT (GB). SILLEM, Robin, Frank, Hamilton [GB/GB]; Northern Electronic Technology Limited, Tedco Business Centre, Viking Industrial Park, Jarrow, Tyne & Wear NE32 3DT (GB). (74) Agent: DEALTRY, Brian; Eric Potter Clarkson, St. Mary's Court, St. Mary's Gate, Nottingham NG1 1LE (GB).</p>		<p>(81) Designated States: JP, US, European patent (AT, BE, CH, DE, DK, ES, FI, FR, GB, GR, IE, IT, LU, MC, NL, PT, SE). Published With international search report.</p>

(54) Title: DIAGNOSTIC SYSTEM FOR A JACQUARD MACHINE



(57) Abstract

A diagnostic system for a jacquard machine having a plurality of heald hooks (16) moveable between at least two discrete shed positions, the system including visual sensing means (30) for producing a visual image of hooks (16) located at one of said shed positions during each weaving cycle, and control means (49) for comparing said visual image with a predetermined shed pattern for each corresponding weaving cycle in order to determine whether or not all the appropriate hooks have been selected to define the required shed pattern.

FOR THE PURPOSES OF INFORMATION ONLY

Codes used to identify States party to the PCT on the front pages of pamphlets publishing international applications under the PCT.

AL	Albania	ES	Spain	LS	Lesotho	SI	Slovenia
AM	Armenia	FI	Finland	LT	Lithuania	SK	Slovakia
AT	Austria	FR	France	LU	Luxembourg	SN	Senegal
AU	Australia	GA	Gabon	LV	Latvia	SZ	Swaziland
AZ	Azerbaijan	GB	United Kingdom	MC	Monaco	TD	Chad
BA	Bosnia and Herzegovina	GE	Georgia	MD	Republic of Moldova	TG	Togo
BB	Barbados	GH	Ghana	MG	Madagascar	TJ	Tajikistan
BE	Belgium	GN	Guinea	MK	The former Yugoslav Republic of Macedonia	TM	Turkmenistan
BF	Burkina Faso	GR	Greece	ML	Mali	TR	Turkey
BG	Bulgaria	HU	Hungary	MN	Mongolia	TT	Trinidad and Tobago
BJ	Benin	IE	Ireland	MR	Mauritania	UA	Ukraine
BR	Brazil	IL	Israel	MW	Malawi	UG	Uganda
BY	Belarus	IS	Iceland	MX	Mexico	US	United States of America
CA	Canada	IT	Italy	NE	Niger	UZ	Uzbekistan
CF	Central African Republic	JP	Japan	NL	Netherlands	VN	Viet Nam
CG	Congo	KE	Kenya	NO	Norway	YU	Yugoslavia
CH	Switzerland	KG	Kyrgyzstan	NZ	New Zealand	ZW	Zimbabwe
CI	Côte d'Ivoire	KP	Democratic People's Republic of Korea	PL	Poland		
CM	Cameroon	KR	Republic of Korea	PT	Portugal		
CN	China	KZ	Kazakistan	RO	Romania		
CU	Cuba	LC	Saint Lucia	RU	Russian Federation		
CZ	Czech Republic	LI	Liechtenstein	SD	Sudan		
DE	Germany	LK	Sri Lanka	SE	Sweden		
DK	Denmark	LR	Liberia	SG	Singapore		
EE	Estonia						

DIAGNOSTIC SYSTEM FOR A JACQUARD MACHINE

The present invention relates to a diagnostic system for a jacquard machine, in particular, a jacquard machine for a weaving loom.

5 Jacquard machines for weaving looms usually include a plurality of heald hooks arranged in rows extending in the weft direction, the rows being located side by side in the warp direction.

Each row of hooks is acted upon by a reciprocating knife such that
10 selected hooks in the row are moved from one shed position to and held at another shed position during a pick in the weaving cycle. Depending upon the type of jacquard machine, the knife may move only selected hooks from said one shed position or may move all hooks from said one shed position such that selected hooks can be retained at said one shed
15 position.

In order to ensure that fabric being woven has no faults caused by failure to select a chosen heald hook it is known to provide detection means which act to produce a signal should the chosen heald hook not be
20 selected. Such detection means are usually in the form of mechanically operated electrical switches and these tend to be unreliable. In addition, in a Jacquard machine, there can be several thousand heald hooks and so the use of mechanical switches becomes increasingly more unsatisfactory and costly.

25

According to one aspect of the present invention, there is provided a diagnostic system for a jacquard machine having a plurality of heald hooks movable between at least two discrete shed positions, the system including visual sensing means for producing a visual image of hooks
30 located at one of said shed positions during each weaving cycle, and

control means for comparing said visual image with a predetermined shed pattern for each corresponding weaving cycle in order to determine whether or not all the appropriate hooks have been selected to define the required shed pattern.

5

Preferably the visual sensing means comprises at least one video camera located to one side of the jacquard machine so as to view the heald hooks at an inclined angle.

10

Preferably datum means are provided to enable the control means to determine the location of each heald hook. The datum means may be in the form of a pattern located around the periphery of the rows of heald hooks to thereby enable the control means to create an orthogonal virtual grid of imaginary lines, the location of each hook being at the intersection of said imaginary lines.

15

The heald hooks may be adapted to make them more visibly distinct, for example by being coated with a suitable paint.

20

According to another aspect of the present invention there is provided a diagnostic method for a jacquard machine having a plurality of heald hooks movable between at least two shed positions, the method including the steps of creating a visual image of hooks located at one of said shed positions during each weaving cycle, and comparing said visual image with a predetermined shed pattern for each corresponding weaving cycle in order to determine whether or not all the appropriate hooks have been selected to define the required shed pattern.

25

Various aspects of the present invention are hereinafter described with reference to the accompanying drawings in which:-

30

Figure 1 is a schematic perspective view of the upper part of a Jacquard machine including a diagnostic system according to the present invention;

Figure 2 is a schematic diagram showing the image viewed by the camera in Figure 1.

A jacquard machine 10 is schematically shown in Figures 1 and 2 having a frame 12 in which a plurality of lifting knives 14 are mounted for reciprocal movement.

Each knife 14 co-operates with a row 15 of heald hooks 16, there being shown eight rows 15 of heald hooks and eight lifting knives. It will be appreciated that any number of knives 14 and corresponding rows 15 may be provided. Each row 15 contains the same number of heald hooks 16. The heald hooks 16 are regularly spaced along the corresponding knife and are aligned with heald hooks 16 located at the same position on neighbouring rows.

Accordingly the heald hooks 16 are also arranged in rows 18 which are spaced side by side along the knives 14.

It will be appreciated therefore that the heald hooks 16 are arranged in an orthogonal grid pattern composed of rows 15 and rows 18, each heald hook 16 being located at the intersection of each row 15 and row 18.

In accordance with the present invention there is provided a diagnostic system which includes a visual sensing means 30 and an electronic control 40.

The visual sensing means 30 is preferably in the form of a video camera 31 which is mounted above and to one side of the top of the jacquard machine 10 so as to view hooks 16 as they rise to their upper shed position. The image viewed by the camera is schematically shown
5 in Figure 2.

The electronic control 40 preferably comprise a computer which receives the video image from the camera preferably via a digitizer interface.

10

The computer is arranged to receive an operating signal *O* during each weaving cycle. The operating signal *O* may be generated by for example a sensor on the drive shaft 42 of the jacquard in the case of a jacquard having mechanically operated pattern selection or may be
15 generated from the electronic control of a jacquard having electronically controlled pattern selection.

On receipt of signal *O*, the computer is arranged to grab an image from the camera and use the image to identify the presence of hooks
20 located at their upper shed position and then determine whether or not all selected hooks have been raised.

Preferably the camera is a monochrome camera and preferably the upper portion 16a of the hooks 16 have been adapted, for example by
25 painting to define a high contrast with their background. In this respect, preferably the upper portions 16a and painted white so that the upper portions 16a when viewed by the camera appear light compared to the background.

30 Accordingly the presence of a hook 16 at its upper shed position is

identified in the grabbed image by the computer software locating the areas of bright pixels.

Having identified the presence of a hook, it is necessary for the
5 computer to determine its location in the array of hooks so as to enable the
computer to determine whether or not that hook should be at its upper
shed position.

It is appreciated that the computer could be programmed with a
10 look-up map identifying the locations of each hook. However this would
require the camera to be accurately positioned and for it to remain in that
position during its working life. Accordingly, it is preferred to provide
a system whereby the computer can determine the grid locations of the
head hooks using the image produced by the camera.

15

A first method is to locate targets at predetermined positions on the
jacquard frame 12. For example as seen in Figure 1 a pair of targets
50 may be provided at diagonally opposite corners of the jacquard frame 12.
The shape and contrast of the target 50 is chosen so as to be easily
20 recognised by the software and provides a pair of fixed reference points
in the image produced by the camera.

Prior to a weaving operation, a set-up routine is performed.

25 This initially involves the computer locating the targets 50 and
storing in memory their co-ordinates. The jacquard machine is then run
with a predetermined weave pattern, for example a plain weave, and the
software reconciles the pattern of the lifted hooks 16 in the image with the
predetermined pattern sequence and provides and stores in memory co-
30 ordinates in the image for each hook grid location.

After this set-up procedure, the computer is able to accurately monitor lifting of each hook as long as the camera position does not change. Accordingly the computer preferably continually monitors the coordinates of the viewed targets 50 and compares them with the coordinates stored during set-up. If the comparison shows that the camera position has changed, weaving is stopped and a new set-up routine is performed.

A second method of determining the grid location of each hook 16 is illustrated in Figure 2.

In Figure 2, a rectangular target 60 is provided on the top of the machine frame 12 and is arranged to identify the position of rows 15 and rows 18. The target 60 for example as shown in Figure 2 consists of dark areas 81 contrasting with light areas 82. The dark areas 81 may for example be aligned with each row 15 or 18.

The software is arranged to scan the image and using the target 60 create a virtual grid of imaginary orthogonal lines. The software determines the cross-over points of the orthogonal lines and thereby determines the grid location of each heald hook 16. Scanning of the image to create the virtual grid occurs during each weaving cycle. Accordingly movement of the camera does not affect determination of the grid location of the each hook.

It will be appreciated that it is not necessary to provide a visual identification for every row 15 or 18 since the dimensions of the hook array are known and so some rows positions can be interpolated knowing the positions of the other rows.

Also, since the geometry of the target panel 60 are known, the scanned information used to determine the virtual grid will automatically compensate for perspective errors in the image caused by some hooks being closer to the camera than others.

CLAIMS

1. A diagnostic system for a jacquard machine having a plurality of heald hooks moveable between at least two discrete shed positions, the system including visual sensing means for producing a visual image of hooks located at one of said shed positions during each weaving cycle, and control means for comparing said visual image with a predetermined shed pattern for each corresponding weaving cycle in order to determine whether or not all the appropriate hooks have been selected to define the required shed pattern.
2. A system according to Claim 1 wherein the visual sensing means comprises at least one video camera located to one side of the jacquard machine so as to view the heald hooks at an inclined angle.
3. A system according to Claim 1 or 2 wherein datum means are provided to enable the control means to determine the location of each heald hook.
4. A system according to Claim 3 wherein the datum means is in the form of a pattern located around the periphery of the rows of heald hooks to thereby enable the control means to create an orthogonal virtual grid of imaginary lines, the location of each hook being at the intersection of said imaginary lines.
5. A system according to any preceding claim wherein the hooks are adapted to make them visibly distinct.

6. A diagnostic system for a jacquard mechanism substantially as herein described with reference to and as illustrated in the accompanying drawings.

7. A diagnostic method for a jacquard machine having a plurality of heald hooks moveable between at least two shed positions, the method including the steps of creating a visual image of hooks located at one of said shed positions during each weaving cycle, and comparing said visual image with a predetermined shed pattern for each corresponding weaving cycle in order to determine whether or not all the appropriate hooks have been selected to define the required shed pattern.

8. A diagnostic method for a jacquard machine substantially as herein described with reference to the accompanying drawings.

1/1

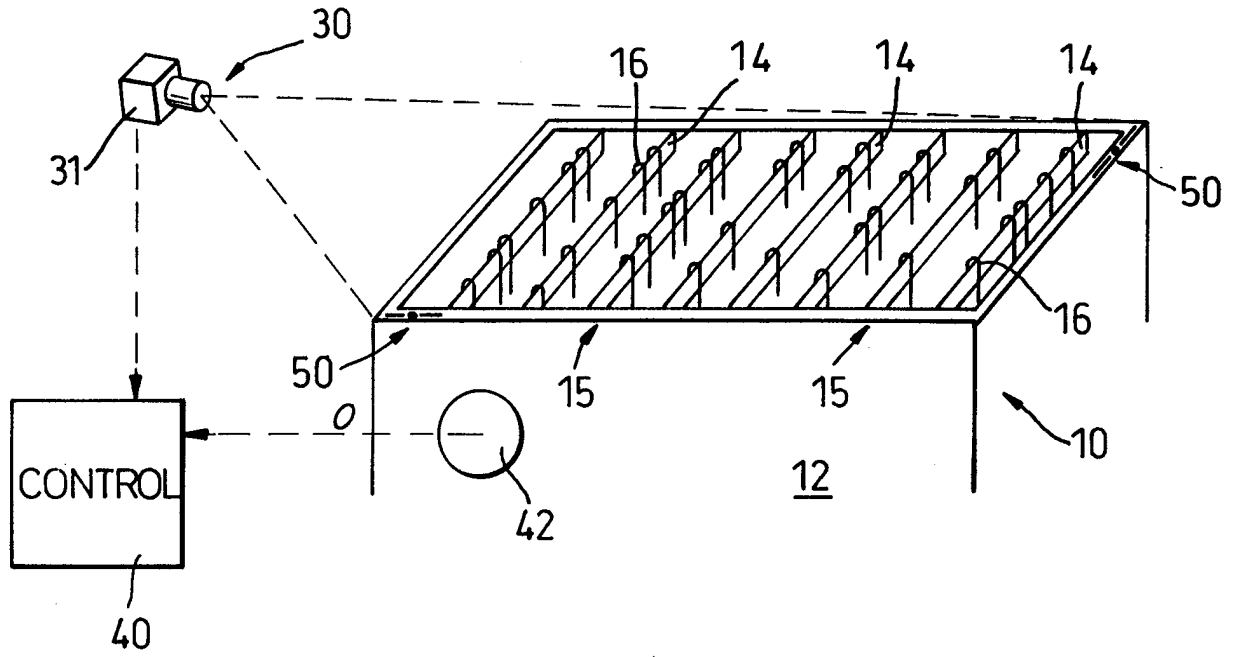

Fig. 1

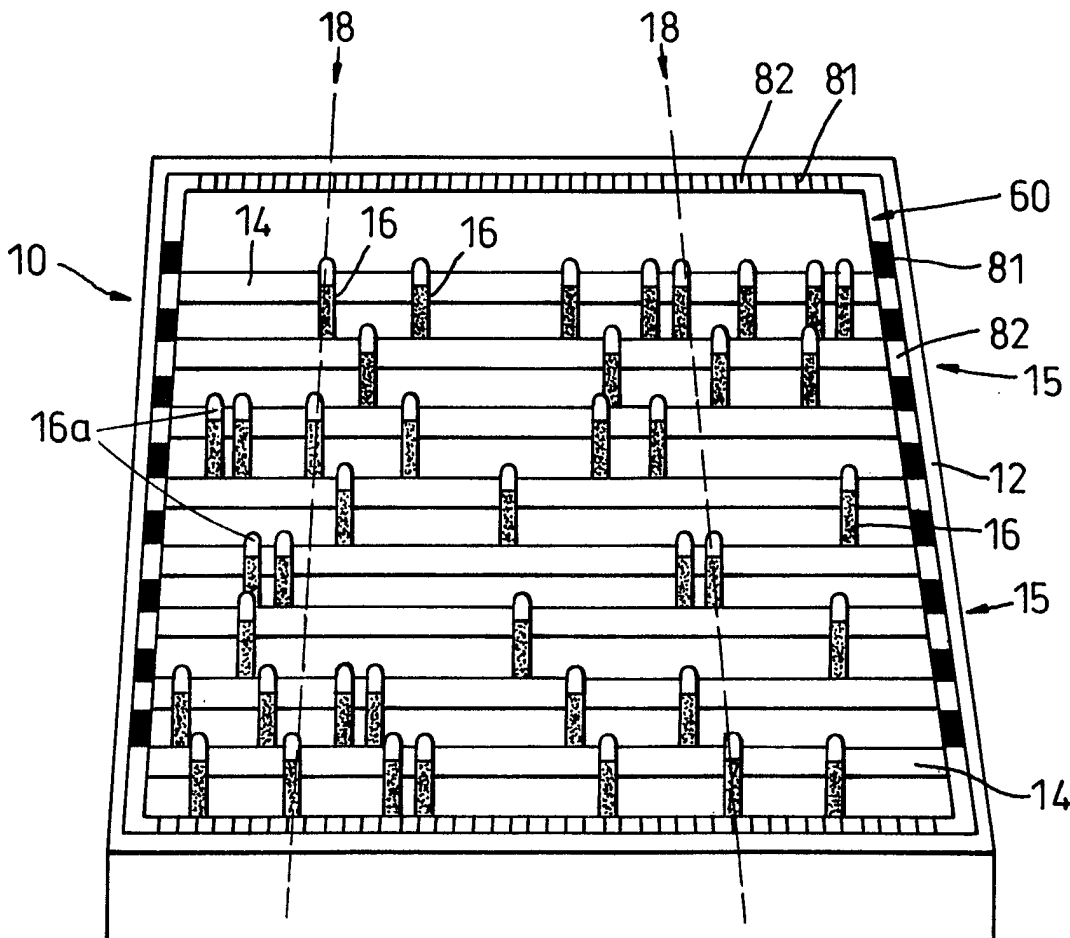

Fig. 2

INTERNATIONAL SEARCH REPORT

National Application No PCT/GB 97/03366
--

A. CLASSIFICATION OF SUBJECT MATTER
 IPC 6 D03D51/46 D03C3/24 D03C17/06

According to International Patent Classification (IPC) or to both national classification and IPC

B. FIELDS SEARCHED

Minimum documentation searched (classification system followed by classification symbols)
 IPC 6 D03D D03C

Documentation searched other than minimum documentation to the extent that such documents are included in the fields searched

Electronic data base consulted during the international search (name of data base and, where practical, search terms used)

C. DOCUMENTS CONSIDERED TO BE RELEVANT

Category *	Citation of document, with indication, where appropriate, of the relevant passages	Relevant to claim No.
A	DE 36 18 467 A (THIEME) 8 January 1987 -----	
A	US 4 019 036 A (HIRAMATSU) 19 April 1977 -----	

Further documents are listed in the continuation of box C.

Patent family members are listed in annex.

* Special categories of cited documents :

- "A" document defining the general state of the art which is not considered to be of particular relevance
- "E" earlier document but published on or after the international filing date
- "L" document which may throw doubts on priority claim(s) or which is cited to establish the publication date of another citation or other special reason (as specified)
- "O" document referring to an oral disclosure, use, exhibition or other means
- "P" document published prior to the international filing date but later than the priority date claimed

- "T" later document published after the international filing date or priority date and not in conflict with the application but cited to understand the principle or theory underlying the invention
- "X" document of particular relevance; the claimed invention cannot be considered novel or cannot be considered to involve an inventive step when the document is taken alone
- "Y" document of particular relevance; the claimed invention cannot be considered to involve an inventive step when the document is combined with one or more other such documents, such combination being obvious to a person skilled in the art.
- "&" document member of the same patent family

Date of the actual completion of the international search 12 March 1998	Date of mailing of the international search report 23/03/1998
---	---

Name and mailing address of the ISA European Patent Office, P.B. 5818 Patentlaan 2 NL - 2280 HV Rijswijk Tel. (+31-70) 340-2040, Tx. 31 651 epo nl, Fax: (+31-70) 340-3016	Authorized officer Boutelegier, C
--	---

INTERNATIONAL SEARCH REPORT

Information on patent family members

national Application No

PCT/GB 97/03366

Patent document cited in search report	Publication date	Patent family member(s)	Publication date
DE 3618467 A	08-01-87	NONE	
US 4019036 A	19-04-77	JP 51029563 A DE 2458927 A GB 1495967 A	12-03-76 05-08-76 21-12-77