

A. S. DRISKO.
WATER METER.

APPLICATION FILED DEC. 29, 1910.

1,002,139.

Patented Aug. 29, 1911.

2 SHEETS-SHEET 1.

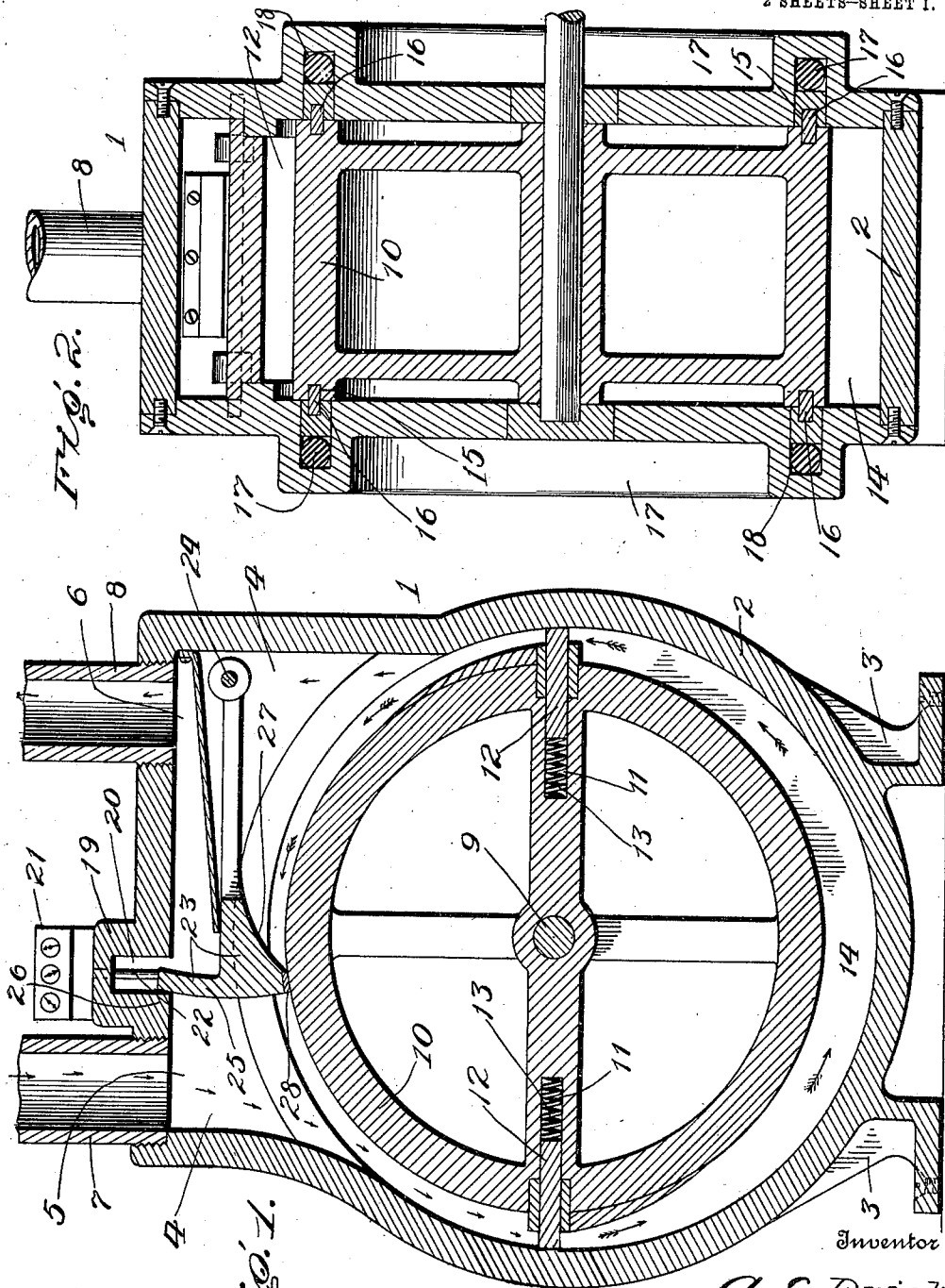

Witnesses
M. M. Beall
E. W. Thomas

FIG. 1.

Inventor
A. S. Drisko

By *J. M. Crutcher*
 Attorney

A. S. DRISKO.

WATER METER.

APPLICATION FILED DEC. 29, 1910.

Patented Aug. 29, 1911.

2 SHEETS-SHEET 2.

1,002,139.

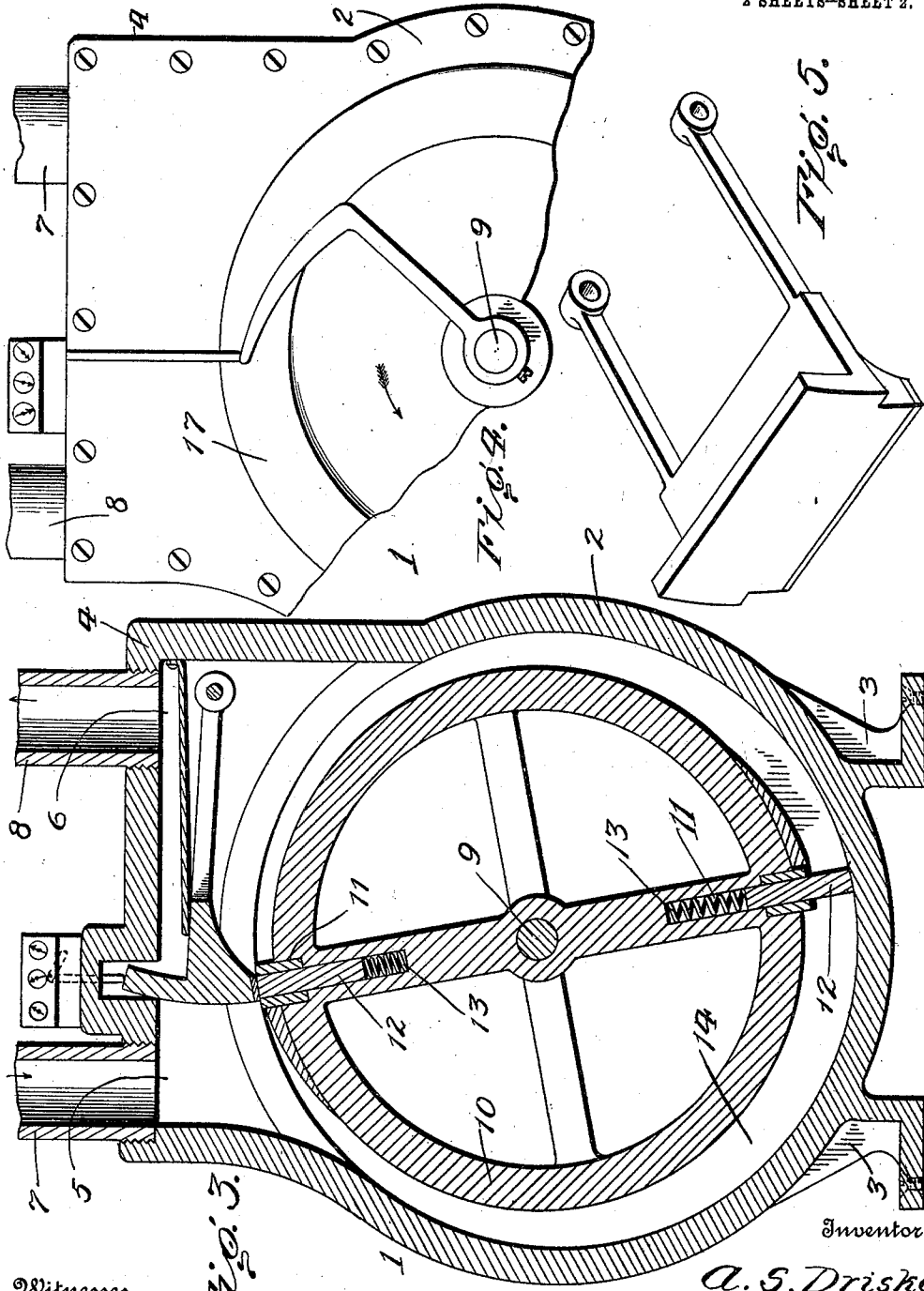

Witnesses

M. M. Beall
E. H. Thomas

Inventor

A. S. Drisko

By J. C. W. Intire

Attorney

UNITED STATES PATENT OFFICE.

ALONZO S. DRISKO, OF BOSTON, MASSACHUSETTS.

WATER-METER.

1,002,139.

Specification of Letters Patent. Patented Aug. 29, 1911.

Application filed December 29, 1910. Serial No. 600,002.

To all whom it may concern:

Be it known that I, ALONZO S. DRISKO, a citizen of the United States, residing at Boston, in the county of Suffolk and State of Massachusetts, have invented certain new and useful Improvements in Water-Meters; and I do hereby declare the following to be a full, clear, and exact description of the invention, such as will enable others skilled in the art to which it appertains to make and use the same.

This invention relates to new and useful improvements in meters for registering the quantity of fluid passing therethrough, and also adapted to be used when desired as a motor for driving purposes.

The object of this invention is to improve and simplify devices of this character, rendering them comparatively simple and inexpensive to manufacture, reliable and efficient in use, and readily operated.

With the above and other objects in view, this invention resides in the novel features of construction, formations, combinations and arrangements of parts to be hereinafter more fully described, claimed and illustrated in the accompanying drawings, in which—

Figure 1 is a vertical longitudinal sectional view taken through my meter; Fig. 2 is a transverse sectional view taken on the line 2—2 of Fig. 1; Fig. 3 is a similar view to Fig. 1, but showing the drum contained therein in a different position; Fig. 4 is a fragmentary end view, illustrating a modified form of my invention, and Fig. 5 is a detail perspective view of the registering blade detached.

Referring to the drawings by characters of reference, the numeral 1 designates generally my improved device, comprising a substantially annular casing 2, mounted upon suitable legs or supports 3, and offset at its opposite extremity to provide a pair of angular extensions 4, provided in their upper faces with internally threaded inlet and outlet ports 5 and 6, adapted to receive the lower threaded extremities of inlet and outlet pipes 7 and 8, whereby fluid may be admitted and expelled from the casing and

operate suitable mechanism for registering the quantity of fluid passing therethrough, as will be hereafter described.

A shaft 9 is journaled a slight distance above the center of the annular casing 2, and supports in eccentric relation to this said casing a registering wheel 10. Seats or recesses 11 are formed at diametrically opposite portions upon the periphery of this wheel 10, and have located therein blades or paddles 12, which are normally pressed into engagement with the inner surface of the casing 2 by means of helical springs 13, the said blades 12 adapted to close the passage 14, located between the periphery of the said wheel 10 and the inner surface of the before-mentioned casing 2.

Referring more particularly to Fig. 4 of the drawing, the link which extends from the registering device is engaged by the cam end of an arm secured to the shaft 9 which serves to operate the said registering device upon the rotation of the shaft.

In order to prevent any leakage, the opposite sides of the wheel 10 are provided with circular grooves 15, adapted to receive rings 16, carried in grooves formed centrally in flanged guides 17, which guides are normally pressed so that the rings 16 are always in engagement with the circular grooves 15 by means of resilient members 18, formed of rubber or other suitable material.

Upon the upper portion of the angular extension 4, in the side of the casing adjacent the inlet 5 is formed a boss 19, provided with a vertically extending passage 20 formed centrally therein, and carries mounted thereon a suitable registering device 21, adapted to be operated through the medium of a link 22 by an indicating plate 23, which is pivoted, as indicated by the numeral 24, at one end within the angular member 4 adjacent the outlet 6, and is provided upon its opposite end with an upwardly extending arcual plate 25, which extends into the passage or channel 20 and contacts at all times with the lower corners 26 of the said channel and prevents the fluid in passing through

the inlet 5 from obtaining access to the outlet passage without first passing around the wheel 10. The lower portion of the plate 23 is curved, as indicated at 27, to meet the lower end of the arcual plate 25, for a purpose which will be hereafter described. The lower portion of this arcual plate 25 is reinforced, as at 28, to prevent its wearing by constant engagement with the periphery of the operating wheel 10. As the fluid passes into the casing through the inlet port 5 it will pass around between the wheel 10 and engage the blade 12, manifestly driving the same in the direction of the outlet port, at the same time rotating the wheel 10 to which the plate 12 is secured and also the shaft 9 upon which the wheel 10 is secured. As the blade 12 reaches the plate 23 it will slide under the same, and obviously as the wheel at the upper portion of the casing will be nearer the inner surface thereof, owing to the fact that the wheel is pivoted eccentrically within the casing, it will force the plate 23 upward and operate the registering device 21 through the medium of the before-mentioned link 22, to indicate the quantity of fluid passing through the casing upon one-half revolution of the wheel. In the meantime the opposite blade 12 has advanced beyond the inlet port 5, and the operation will be repeated.

In case it is desired to use the previously described device as a motor, a pulley not shown in the drawings may be mounted at a convenient point upon the shaft 9 which projects beyond the side of the casing 1 and a belt not shown, or the like, may be passed over said pulley, the said belt being rotated by the passage of the water through the casing.

From the foregoing disclosure it will be manifest that a meter and a motor are provided for which will fulfil all the necessary requirements of such a device.

Having thus fully described this invention, what I claim as new and desire to secure by Letters Patent is:

1. A device of the character described comprising a casing, a drum rotatable therein, blades carried by the drum, an indicating plate operatively engaged by the blades and means coöperating therewith for registering the number of revolutions of the drum.

2. In a device such as described the combination with a casing, means rotatably mounted within the casing for engagement with an indicating plate secured therein, and means coöperating with said indicating plate for registering the number of revolutions of the operating means.

3. In a device such as described the combination with a casing, of a drum rotatably mounted therein, means carried by the drum for rotating the same by the action of fluid passing through said casing, rings engaging

the casing and the drum for preventing any leakage from the casing, and means coöperating with the drum for registering the revolutions thereof.

4. In a device of the character described the combination of a casing, a drum rotatably mounted therein, blades seated in recesses formed within the drum, means for yieldingly forcing the blades into engagement with the casing, a plate hingedly secured within the casing and operatively engaged by the blades, and a link secured to the said plate for the purpose of operating a suitable registering device adapted to be mounted adjacent the casing.

5. A device of the character described comprising a casing, a drum mounted therein, blades seated in recesses located in the drum, means for yieldingly forcing the blades into engagement with the casing, a plate pivoted within the casing and normally resting upon the drum, the said plate adapted to be operated by the rotation of the drum, a registering device mounted upon the casing, and means connecting the plate with the registering device, substantially as and for the purposes hereinbefore described.

6. The combination with a casing of a drum rotatably mounted eccentrically therein, blades carried by the drum for the purpose of rotating the same by the action of fluid while passing through said casing, a plate hinged within the casing and adapted to rest normally upon the periphery of the drum and be operated by the blades passing thereunder, a registering device mounted upon the casing, a link depending from the registering device and adapted to be operated by the plate, and rings engaging the casing and the drum for preventing any leakage from the casing, consisting of grooves formed within the casing for the reception of rings adapted to be normally pressed therein, substantially as and for the purposes set forth.

7. In a device such as described the combination with a casing, of a shaft journaled therein, means carried by the shaft for rotating the same by the action of fluid passing therethrough, a registering device mounted upon the casing, an arm carried by the shaft and provided with a cam extension for operating a registering device, and a plate hinged within the casing and adapted to prevent any retrograde movement of the shaft, substantially as and for the purposes hereinbefore described.

8. The combination in a device such as described of a casing, a shaft journaled eccentrically therein, a wheel mounted upon the said shaft, means for preventing leakage between the said wheel and the opposite sides of the casing, blades carried in recesses formed within the periphery of the wheel, means for forcing the blades into engage-

ment with the interior of the casing, an indicating plate pivotally mounted within the said casing, an arcual plate formed upon one end of the indicating plate and engaging the
5 lower end of a channel formed in the casing, the said plate adapted by the rotation of the eccentrically mounted wheel to be raised and operate a suitable registering device mounted

upon the casing, substantially as and for the purposes hereinbefore described.

In testimony whereof I affix my signature in presence of two witnesses.

ALONZO S. DRISKO.

Witnesses:

FRANKLIN B. MACARTHUR,
HENRY B. DRISKO.

Copies of this patent may be obtained for five cents each, by addressing the "Commissioner of Patents,
Washington, D. C."