

H. W. Stetson.

Water Ram.

N^o 100,084.

Patented Feb. 22, 1870.

Fig. 1.

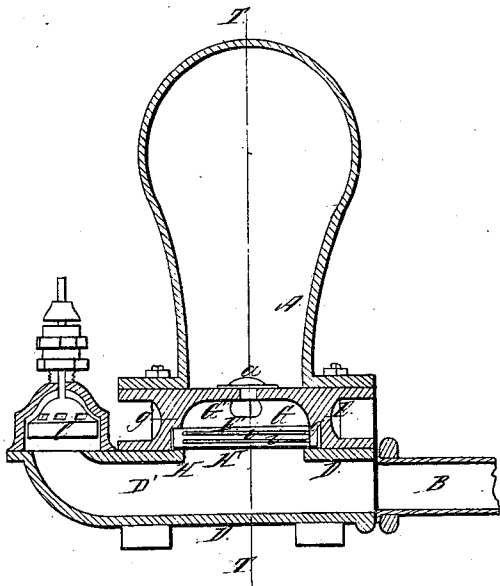

Fig. 2.

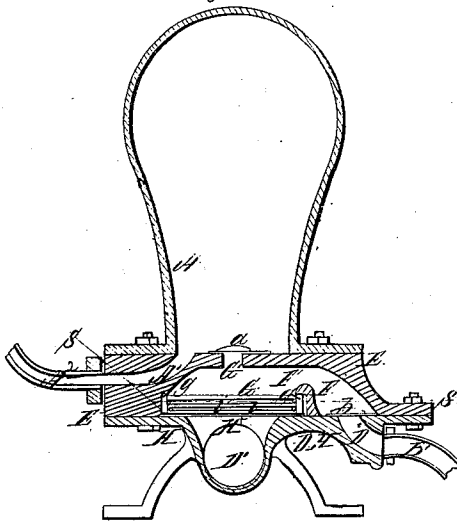

Fig. 3.

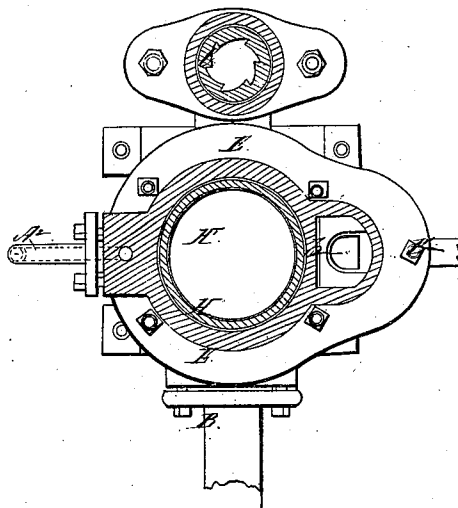

Fig. 4.

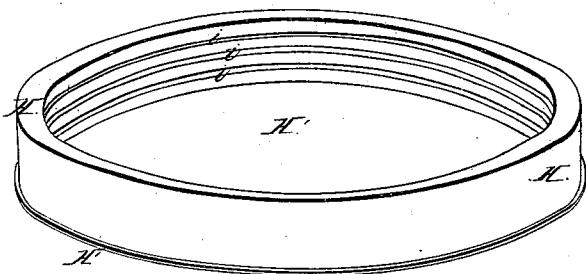
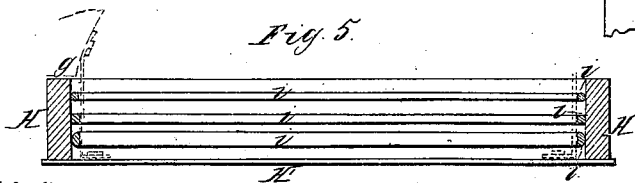

Fig. 5.



Witnesses:
S. Hayford
Rufus Blake

Inventor:
Kimball W. Stetson

United States Patent Office.

KIMBALL W. STETSON, OF KINGSTON, MASSACHUSETTS.

Letters Patent No. 100,084, dated February 22, 1870; antedated February 18, 1870.

IMPROVEMENT IN WATER-RAMS.

The Schedule referred to in these Letters Patent and making part of the same.

To all whom it may concern:

Be it known that I, KIMBALL W. STETSON, of Kingston, in the county of Plymouth, and State of Massachusetts, have invented certain new and useful Improvements in Means for Raising and Forcing Liquids; and I hereby declare the following to be a full and exact description thereof, reference being had to the accompanying drawings which form a part of this specification, in which—

Figure 1 is a vertical longitudinal section;

Figure 2 is a cross-section on the line T T in fig. 1;

Figure 3 is a horizontal section on the line S S in fig. 2;

Figure 4 is a perspective view of the diaphragm detached on a larger scale; and

Figure 5 is a central vertical section of the same.

Similar letters of reference indicate like parts in all the figures.

My invention relates to raising and forcing water and other liquids by hydraulic or other pressure, and is particularly adapted for use as applied to a hydraulic ram, in which position it is described in this specification.

The invention consists in the combination of a rigid part with a ring or casing under the edges, which yields by its elasticity, and allows the rigid part to move as the pressure on its faces varies, so as to contract or enlarge the fluid-chambers or spaces on the opposite sides of the compound diaphragm so formed; also, in a certain arrangement of valves, in connection with such compound diaphragm, to control the action of a fluid admitted to one of its sides; also, in the use of rings, or spiral supports in combination with the above, so arranged as to sustain the elastic case without interfering with its action; and, lastly, in the double-chambered hydraulic ram, composed of a suitable diaphragm dividing the fluid cavity, and having valves for controlling the ingress and egress of fluids through connections on one side, and with the ram-valve and driving-pipe on the other side; as more fully set forth below.

To enable others skilled in the art to make and use my invention, I will proceed to describe it by the aid of the drawings and the letters of reference marked thereon.

A is the air-chamber;

B is the driving-pipe; and

C is the choke or stop-valve, which alternately stops and releases the water in the driving-pipe, as is familiar. These parts may be constructed in the same form and operate in the same manner as in any of the varieties of hydraulic rams.

D is a casting of iron, and composes the body of the ram. It is attached to the driving-pipe B and valve C by means of screws in the ordinary manner.

E is another casting of iron, fitting down upon the

casting D, and supporting the air-chamber A. These three castings, A D E, are held securely together by bolts, as represented, and the joints between them are made tight by thin sheets of leather, rubber, lead, or other soft material placed between them.

The casting E has two recesses or chambers, F and G, formed in its lower surface.

These chambers connect together within the casting through the passage F', and also connect with the interior of the air-chamber A through the passage G', which is covered by the self-acting valve *a*.

A passage, D², in the casting D, communicates at one end with the pipe B', which is connected with a suitable reservoir for supplying pure water or other liquid desired to be raised.

The other end of this passage D² opens into the recess or chamber F, within the casting E, and is covered by the self-acting valve *b*.

The recess G is fitted to receive the annular rubber spring H, the upper face of which rests against a suitable shoulder, *g*, formed in the casting E, as represented, while the lower face presses upon the circular plate H', which rests upon the casting D, and covers a hole therein opening into the passage D¹, connecting the interior of the driving-pipe B with the valve C, as represented.

The annular rubber spring H and plate H' placed together, as represented, form an elastic and very durable diaphragm which is of great importance. I will now describe them more in detail.

The annular rubber should be formed of the most elastic and durable vulcanized rubber to be procured, and of a little less diameter than the hole in which it is placed. Its depth axially should be slightly greater than the depth of the hole between the shoulder *g* and plate H', so as to press against the shoulder *g* and plate H' sufficiently hard to form a tight joint in both places. The rubber may be cemented to the shoulder *g* and to the plate H', to insure that the joints shall be tight if desired.

The thickness of the rubber radially should be governed by the size of the plate H', and also the depth from which the water is desired to be drawn before it reaches the level of the ram. The larger the plate, as also the deeper the reservoir, the thicker the rubber should be.

Rings *i* are inserted within the annular rubber H, so as to brace it and keep it from collapsing or being forced inward to any great extent, but at the same time to allow it to be compressed and expanded vertically. They are formed of the same outward diameter as the interior of the rubber, and are held in place within the rubber by cement, or they may be made slightly larger than the interior of the rubber, in which case the rubber will cling to them without the cement.

The rings *i* may be made of metal, wood, whale-

bone, rattan, or any material which will keep its shape so as to prevent the rubber from being forced inward, and may be of square, round, or flat section, but I prefer to make them of round brass wire, soldered together in the circular form.

In place of the several separate rings *i*, one continuous wire may be bent spirally around and placed within the annular rubber. Such spiral wire will brace the rubber, and keep it properly distended, and at the same time allow it to expand and contract axially to any necessary extent.

In operating my invention, pure water or other liquid to be raised or forced is supposed to fill the spaces G' F F' in the casting E. Other water which may be dirty, warm, or otherwise unfit for use or for mingling with the liquid to be raised, but which has a sufficient head, is then passed through the driving-pipe B, passage D', and past the valve C in the usual manner.

At each closing of the valve C, the sudden pressure in the passage D' (caused by the inertia of the water in the driving-pipe) against the plate H' forces it upward by compressing the rubber H, and thereby reduces the space within the cavity G above it, and forces a quantity of the water contained within the recess G through the passage G', and past the valve *a*, into the air-chamber A.

So soon as the momentum of the water in the driving-pipe is overcome, the usual reaction takes place, which relieves the pressure within the passage D', and allows the valve C to open by its own weight, in the ordinary manner, when the water in the pipe B again flows forward to escape past the valve C.

This reduction of pressure allows the expansive force of the rubber H to urge down the plate H', and enlarge that portion of the space G, which is contained within the rubber.

This enlarged space is thereupon filled by water drawn in past the valve *b* from the pipe B' and the connected reservoir.

When the valve C again closes, more water is again forced past the valve *a* into the air-chamber A, when the rubber, again expanding, fills the space above the diaphragm, as before described.

This operation of filling the space above the yielding part or diaphragm H H' with fresh water drawn past the valve *b* by the expansive or downward tendency of the diaphragm, and of emptying past the valve *a* by the pressure caused by the sudden stoppage of the water within the driving-pipe B, is repeated indefinitely, thereby drawing water from the reservoir to which the pipe B' is attached, and discharging it into the air-chamber A, from whence it is conveyed away through the passage A' and pipe A² to the desired point.

It is obvious that as much water will not be forced into the air-chamber A as if there were no diaphragm intervening, for the reason that a part of the power of the water is expended in forcing up the diaphragm.

It is also obvious that the force exerted to press the diaphragm up may again be utilized (or a great part of it) in sucking the water from a lower elevation, so that in reality nearly the whole power of the water, or so much thereof as in ordinary rams, may be utilized in the two operations of drawing and forcing the liquid.

When the water is required to be drawn from a considerable depth, the rubber H may not expand sufficiently to bring the plate H' entirely down upon the casting D, as is the case when it is raised only a little distance; but the rubber will always expand far enough to reduce its expansive force to a degree about equal to the resistance of the water contained in the pipe B', acting upon the area of the plate H', thereby insuring that the expansive power of the rubber will be but slightly, if any, in excess of the press-

ure due to the height from which the water has been already drawn.

A simple sheet of elastic rubber stretched across the recess G, between the parts D and E, may operate successfully for a time as a diaphragm, but the continual combined stretching and bending action will destroy its utility in a short time.

A sheet of leather, rubber, or other flexible material which will not allow the fluids to pass through it, may be placed, as above, between the parts D and E, and may be strengthened by the addition of a disk or plate near the center, upon which a metal or other spring may press, to form, or assist to form its elastic power; or a diaphragm may be made in the form of a hollow tube, of elastic rubber, attached firmly at one end to a plate, and the other secured to the lower part of the recess G, and allowing the plate to stretch the rubber instead of compressing it; but all such forms in which the material is forced to expand or stretch beyond its natural size I do not consider so desirable as the form represented.

I propose to use the rings or supports *i* on either the interior or exterior of the annular rubber—in some cases on one side, and in some cases on the other, but always opposite to that upon which the pressure is greatest.

I also steady the rings *i*, to insure that the rubber H shall not swing or move laterally in any direction, by a rigid cylinder or other rigid guides placed upon the plate H', or attached to the casting E.

Such guides are shown in red lines in fig. 5. That shown on the right of the figure is attached to the plate alone, and, when used, the casting E above the shoulder *g*, must be recessed, so as to allow the guide to rise with the plate.

The guides shown on the left of the figure are attached both to the plate H' and to the casting E, and slide one within the other like a telescope.

I have represented my diaphragm in a circular form, but any other form may be used with success in which the strip of rubber H and shoulder *g* conform to the plate H', so as to leave a portion of the chamber G inclosed within the rubber.

It is evident that any means which will alternately compress or force upward the diaphragm H H', and in turn alternately release the same, may be made as effective in sucking and forcing up the liquid as the pressure produced by the sudden stoppage of a current of water, as is the case in the operation of a hydraulic ram.

Having now fully described my invention,

What I claim as new therein, and desire to secure by Letters Patent, is as follows:

1. The elastic ring or casing, of rubber or analogous yielding material, H, in combination with the rigid covering part H', and adapted to form therewith a movable side or diaphragm for the fluid-cavity G by the direct compression or expansion of the yielding material, substantially as and for the purposes herein set forth.

2. The valves *a* and *b*, arranged to operate in combination with the diaphragm H H', substantially in the manner and for the purpose herein set forth.

3. The rings *i*, in combination with the diaphragm H H', so as to brace and support the elastic material, substantially in the manner set forth.

4. The double-chambered hydraulic ram above described, having the valves *a b* communicating with the chamber G, and having the valve C and driving-pipe, communicating with the chamber or passage D', and having a suitable diaphragm or yielding partition to separate the chamber G and passage D', and arranged for joint operation substantially as and for the purposes herein set forth.

Witnesses: KIMBALL W. STETSON

S. HOSFORD,

RUFUS BLAKE.