

- (21) Application No. 22855/77 (22) Filed 30 May 1977  
 (31) Convention Application No. 51/070243U (32) Filed 31 May 1976 in  
 (33) Japan (JP)  
 (44) Complete Specification published 23 Jan. 1980  
 (51) INT. CL.<sup>3</sup> F16B 17/00  
 (52) Index at acceptance  
 F2M 203 223 231 232 282 C1



## (54) A JOINT ASSEMBLY

- (71) We, YOSHIDA KOGOYO K.K., a corporation duly organized under the laws of Japan and existing at No. 1, Kanda Izumi-cho, Chiyoda-ku, Tokyo, Japan, do hereby declare the invention, for which we pray that a patent may be granted to us, and the method by which it is to be performed, to be particularly described in and by the following statement:—
- 10 This invention relates to a corner joint structure for balustrades.
- The prior art includes a variety of corner joint structures for balustrades in which a pair of generally horizontally disposed rail members are butt-jointed together at their mitered ends, the rail members being fixedly supported by a vertical corner post or baluster at their miter-jointed ends. Most of these known corner joint structures are somewhat complicated in construction and hence require much time and effort for installation. Another disadvantage is that mitered ends of a pair of horizontal rail members could not always be held in intimate butt-joint relation to each other.
- 25 According to the invention there is provided a joint assembly comprising a pair of rails mitred for butt-jointing together at an angle, a post for supporting the rails in jointed condition, fixing plate means on the top of the post for attachment to both rails, an aperture in the top of the post and plug means on both rails positioned to co-operate mutually together to provide a plug complementary to the aperture in the post to locate the rails in their assembled position.
- The fixing plate means may comprise a plate held with one surface against and fixedly secured to the upper end of the post the rails being held at their bottoms against the other surface of the plate, the plate having a major portion covering the upper end of the post and a pair of mounting portions extending from said major portion in the directions of the lengths of the rails and the plate having a register hole forming the aperture in the top of the post formed through its major portion and the plug means may comprise a pair of register members of identical shape fixedly secured respectively to the bottoms of the rails immediately adjacent to their mitered ends, the register members being held together and snugly fitted in the register hole. Fastening means may be provided for securing the rails to the fixing plate, the fastening means passing through the mounting portions of the plate into the bottom of the rails.
- 50 The invention will now be described in greater detail, by way of example, with reference to the drawings, in which:
- Figure 1 is an exploded, perspective view of a portion of a corner joint assembly provided in accordance with the present invention;
- Figures 2 and 3 are perspective views of a register member incorporated in the corner joint assembly.
- Figure 4 is a vertical cross-sectional view of the corner joint assembly; and
- Figure 5 is a plan view of the corner joint assembly;
- Figure 1 shows a portion of a corner of a balustrade 10 in which a joint assembly 11 of this invention is provided, the balustrade 10 comprising a pair of horizontally disposed rail members 12, 13 having one of their ends 14, 14 miter-jointed together, and a vertical tubular corner post or baluster 16 of a square cross-section having an upper end thereof fixed with respect to the rail members 12, 13 at their miter-jointed ends. The rail members 12, 13 extend substantially at a right angle to each other. Each of the rail members 12, 13 includes a hollow body of generally rectangular cross-section having a downwardly opening channel portion 17 formed

on its bottom 18 and extending along the entire length thereof. The channel portion 17 is defined by a pair of arms 17a,17a and a base 17b interconnecting the arms at their upper edges and is disposed centrally of the width of the rail member.

The angle plate 19 is fixedly secured to the upper end of the vertical tubular post 16 by a plurality of screws 20 passing through the angle plate 19 into the upper peripheral edge of the vertical post 16. The angle plate 19 is of a generally square shape having one corner removed to provide a notch 21 of a L-shaped contour. Adjacent edges 19a,19a of the angle plate 19 lie flush with two adjacent sides 16a,16a of the vertical post 16, respectively, and the edges 21a,21b defining the L-shaped notch 21 lie in planes of the other two adjacent sides 16a,16a, respectively. The angle plate 19 includes a square major portion 19b bounded by the upper peripheral edge of the vertical post 16 and covering the upper end thereof, and a pair of integral mounting portions 19c,19c extending from the major portion 19b in the directions of the lengths of the horizontal rail members 12,13, respectively. Each of the mounting portions 19c,19c has a pair of screw holes 19d,19d therethrough. The angle plate 19 has a register hole 22 of a square shape formed through the major portion 19b, the register hole 22 being disposed coaxially with the vertical tubular post 16, with the four edges 22a defining the register hole 22 disposed in parallel with the four sides 16a of the vertical post 16, respectively.

A pair of register members 23 are provided for holding the mitered ends 14,14 of the rail member 12,13 in intimately butt-jointed condition, the register member 23 being shown upside down in Figures 2 and 3. Each of the register members 23,23 has a hollow body of a triangular cross-section having a base 23a in the shape of a right triangle and a pair of generally square walls 23b,23b extending from right-angled edges of the base 23a, the base 23a having a screw hole 23c therethrough. Each of the walls 23b,23b has its lower edge portion 23d directed inwardly, and has a lug 24 disposed immediately adjacent to the inwardly directed lower edge portion 23d, the lug 24 having the cross-section of a trapezoid having a pair of upper and lower inclined surfaces 24a,24a, and the lower inclined surface 24a merging into the outer surface of the inwardly directed lower edge portion 23d.

An upper half portion of each of the register members 23,23 is snugly received in the channel portion 17 adjacent to the mitered end 14 of the rail member 12, (13) and fixedly secured thereto by a screw 25 passing through the screw hole 23c and the

base 17b of the channel portion 17, with one of the walls 23b,23b held in contact with the arm 17a and with the other wall extending between the arms 17a,17a. The vertical edges 23e,23e of the walls 23b,23b and the edge 23f of the base 23a contiguous thereto lie substantially flush with the mitered end 14 of each of the rail members 12,13, these edges jointly providing a continuous inner edge 23g of the register member 23 having the shape of an inverted U. The height of the register member 23 is so related to the depth of the channel portion 17 that the lug 24 is located below and adjacent to the bottom 18 of the rail member 12,(13), as shown in Figure 4.

As best shown in Figure 4, the lower half portion of each of the register members 23,23 extending downwardly beyond the bottom 18 of the rail member 12 (13) is received in the register hole 22, with the walls 23b,23b disposed in contiguous relation to the adjacent edges 22a,22a of the register hole 22. The width of each of the walls 23b,23b is substantially equal to the length of each of the edges 22a so that the vertical edges 23e,23e are disposed substantially at the diagonally opposed corners 22b,22b of the register hole 22. The register members 23,23 are held together at their continuous inner edges 23g to jointly provide a cup-shaped configuration of a square cross-section with an open bottom, as shown in Figure 5. The lugs 24,24 of each of the register members 23,23 are held in frictional engagement with the mating adjacent edges 22a,22a of the register hole 22. With this arrangement, the register members are urged toward each other to hold the mitered ends 14,14 of the horizontal rail members 12,13 in intimately butt-jointed relation. The inwardly directed lower edge portions 23d,23d of the walls 23b,23b and the lower inclined surfaces 24a,24a of the lugs 24,24 facilitate the insertion of the register member 23 into the register hole 22.

Each of the rail members 12,13 is mated at the bottom 18 thereof with and fixedly secured to the angle plate 19 by a pair of screws 26,26 passing through the screw holes 19d 19d in the mounting portion 19c and the bottom 18.

#### WHAT WE CLAIM IS:—

1. A joint assembly comprising a pair of rails mitred for butt-jointing together at an angle, a post for supporting the rails in jointed condition, fixing plate means on the top of the post for attachment to both rails, an aperture in the top of the post and plug means on both rails positioned to co-operate mutually together to provide a plug complementary to the aperture in the post to locate the rails in their assembled position.
2. A joint assembly according to claim 1, wherein the fixing plate means comprises 130

an angle plate held with one surface against and fixedly secured to the upper end of the post, the rails being held at their bottoms against the other surface of the plate, the  
 5 plate having a major portion covering the upper end of the post and a pair of mounting portions extending from said major portion in the directions of the lengths of the rails and the plate having a register  
 10 hole forming the aperture in the top of the post formed through its major portion and wherein the plug means comprise register members of identical shape fixedly secured respectively to the bottoms of the rails  
 15 immediately adjacent to their mitered ends, the register members being held together and snugly fitted in the register hole.

3. A joint assembly according to claim 2, wherein a pair of fastening means is provided for securing the rails to the fixing  
 20 plate, the fastening means passing through the mounting portions of the plate into the bottoms of the rails.

4. A joint assembly according to claims  
 25 2 and 3, wherein the rails are disposed substantially at a right angle to each other.

5. A joint assembly according to any one of claims 2 to 4, wherein the post and the register hole are disposed substantially  
 30 coaxially with respect to each other.

6. A joint assembly according to any one of claims 2 to 5 wherein each rail has at the bottom thereof a downwardly opening  
 35 channel portion defined by a pair of arms and a base interconnecting the arms at their upper edges, and the channel portion ex-

tending along the entire length of the rail, and in which the register hole has the shape of a square, and each of the register members having a hollow body of triangular  
 40 cross-section defined by a triangular base and a pair of generally square walls extending from the triangular base at adjacent edges thereof, each of the register members being partially received in the channel  
 45 portion with the triangular base thereof fixedly secured to the base of the channel portion, the register members being held together to provide a cup-shaped configuration of a square cross-section with an open  
 50 bottom, and these portions of the joined register members extending downwardly beyond the bottoms of the rails being snugly received in the register hole, with the square walls in frictional engagement with the four  
 55 edges of the square register hole, respectively.

7. A joint assembly according to claim 4, wherein the walls of each register members have a pair of lugs engaging the mating  
 60 adjacent edges of the register hole and urging the mitered end of the associated rail into intimately butt-jointed engagement with the mitered end of the companion rail.

8. A joint assembly substantially as  
 65 herein described with reference to the drawings.

For the Applicants,  
 J. F. WILLIAMS & CO.,  
 Chartered Patent Agents,  
 34 Tavistock Street,  
 London WC2E 7PB.

FIG. 1

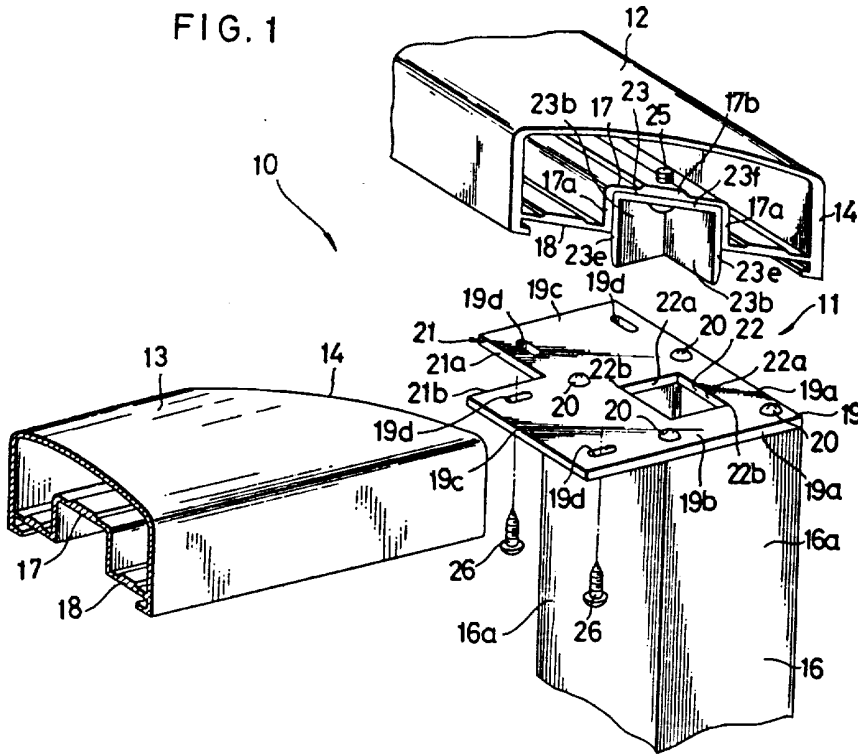

FIG. 2

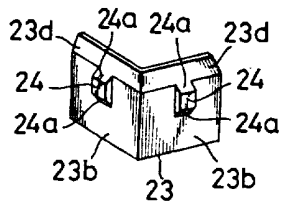

FIG. 3

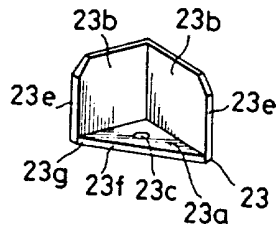

FIG. 5

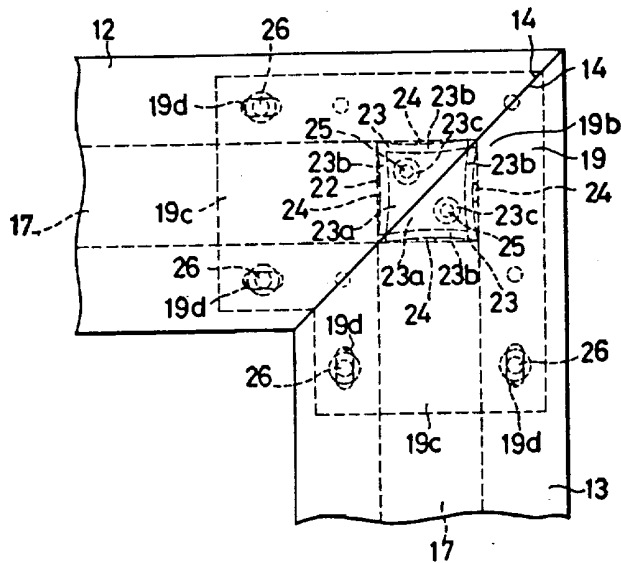

FIG. 4

