

(No Model.)

J. REID.
HOLDER FOR TOILET PAPER.

No. 520,221.

Patented May 22, 1894.

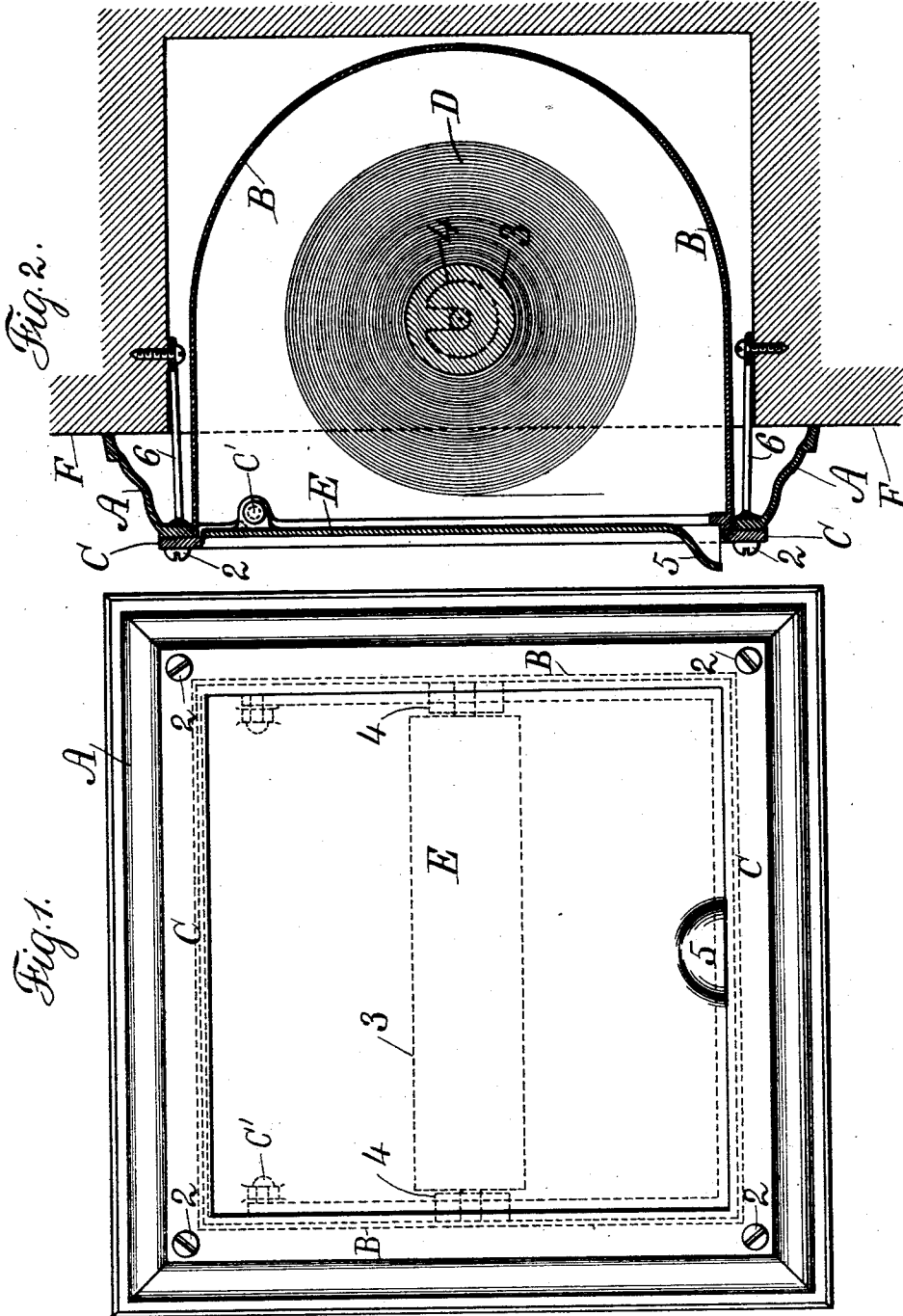

Witnesses:
J. Stait
Chas. Smith

Inventor:
John Reid
per Lemuel M. Terrell

UNITED STATES PATENT OFFICE.

JOHN REID, OF YONKERS, ASSIGNOR TO THE J. L. MOTT IRON WORKS, OF
NEW YORK, N. Y.

HOLDER FOR TOILET-PAPER.

SPECIFICATION forming part of Letters Patent No. 520,221, dated May 22, 1894.

Application filed September 14, 1893. Serial No. 485,460. (No model.)

To all whom it may concern:

Be it known that I, JOHN REID, a citizen of the United States, residing at Yonkers, in the county of Westchester and State of New York, have invented an Improvement in Holders for Toilet-Paper, of which the following is a specification.

In the modern and most approved styles of plumbing, the bath-room is provided with fixtures that are not inclosed with wood-work, in order that all portions of the room may be easy of access for cleaning, and in many instances the walls are covered with vitrified tiles screwed to the plaster and often forming the surface of the brick wall or partition. Holders have been made for rolls of toilet paper, but such holders have projected from the surface of the wall or partition, and have been objectionable in appearance, as well as often inconvenient, as they are liable to be struck by the arm and either loosened from their attaching devices, or the person injured, and where the walls are surfaced with vitrified tiles, it has been very difficult to attach a holder for toilet paper.

The present invention is made to overcome the difficulties before mentioned. I employ a frame of metal, which is fastened permanently to the wall, and in the wall a recess is built and the roll of paper is introduced into a movable case that is attached to the metal frame and sets into the recess in the wall so as to be entirely out of sight, and a swinging cover is provided for the case, so that by lifting this cover the toilet paper can be withdrawn from the roll as required.

In the drawings, Figure 1, is an elevation of the frame and swinging cover, and Fig. 2, is a vertical section of my improved holder.

The frame A, is of metal and preferably nickel plated and polished upon its exterior surface, and the opening in this frame is of a proper size for the reception of a case B, that is advantageously made of sheet metal, connected at its outer edge to a frame C, that is adapted to rest against the surface of the frame A, and to be screwed thereto by the screws 2. And this case B, is of a size and shape adapted to hold a roll D, of toilet paper, the same usually being mounted upon a wooden roll 3, having metal pins at the ends,

forming pivots which pass into notches in the open bearings 4, that are fastened upon the interior surface of the case B in the middle of the end portions of such case. The swinging flap or cover E is pivoted at its upper edges at C' to the frame C, and provided with a lip 5 at the lower edge, by which the finger or thumb can be applied in swinging the cover to open the same, and the surfaces of the cover and the interior surface of the case B are preferably plated or otherwise ornamented so as not to be objectionable in appearance.

The frame A is to be permanently attached to the wall F in any suitable manner. It is usually advantageous to apply wires 6, permanently fastened to the back surfaces of the frame, and adapted to extend into the opening or recess in the wall and to be fastened permanently into the wall for holding the frame A in position. But screws might be employed for holding this frame if the wall or partition contains wood-work, and it will be apparent that in building the wall or fitting up the holder for the toilet paper, the frame A is first screwed in position, and then the case B introduced within the frame so that the same passes into the recess in the wall, and the frame C comes against the surface of the frame A, and is screwed to the same by the screws 2, and the holder is then ready for the reception of the roll of toilet paper, and such roll of paper is out of sight, and there is nothing projecting from the surface of the wall sufficiently to become an inconvenience or to be objectionable in appearance.

I claim as my invention—

1. A holder for a roll of toilet paper, composed of the frame A, permanently fastened to the wall at a recess in the wall; the case B, and frame C, screwed to the frame A by the screws 2, and having bearings 4, for the axis of the roll of toilet paper, substantially as set forth.

2. A holder for a roll of toilet paper, composed of the frame A, permanently fastened to the wall at a recess in the wall; the case B, and frame C, screwed to the frame A, by the screws 2, and having bearings 4, for the axis of the roll of toilet paper, a cover E, hinged

at its upper edge within the frame C, and having a lip 5, at the lower edge, substantially as set forth.

3. A holder for toilet paper composed of an
5 open frame and a closed case permanently
connected at its edges with the frame and extending backwardly therefrom, and having inwardly projecting bearings for the reception of a roll of paper inserted through the
10 open frame, means for securing the frame

and case in position and a pivoted swinging cover acting to close the frame and case, substantially as specified.

Signed by me this 8th day of September,
A. D. 1893.

JOHN REID.

Witnesses:

EDWARD HAMMANN,
HENRY MOSFORD.