



- (51) **International Patent Classification:**  
E04H 4/16 (2006.01)
- (21) **International Application Number:**  
PCT/AU20 11/000800
- (22) **International Filing Date:**  
29 June 2011 (29.06.2011)
- (25) **Filing Language:** English
- (26) **Publication Language:** English
- (30) **Priority Data:**  
2010902875 29 June 2010 (29.06.2010) AU
- (71) **Applicant (for all designated States except US):** POOL-  
RITE RESEARCH PTY LTD [AU/AU]; 415 Creek  
Road, Mt Gravatt, Queensland 4122 (AU).
- (72) **Inventor; and**
- (75) **Inventor/Applicant (for US only):** PALMER, Ross,  
Leslie [AU/AU]; CAPoolrite Research Pty Ltd, PO Box  
520, Mt Gravatt, Queensland 4122 (AU).
- (74) **Agent:** FISHER ADAMS KELLY; Level 29, 12 Creek  
Street, Brisbane, Queensland 4000 (AU).

- (81) **Designated States (unless otherwise indicated, for every kind of national protection available):** AE, AG, AL, AM, AO, AT, AU, AZ, BA, BB, BG, BH, BR, BW, BY, BZ, CA, CH, CL, CN, CO, CR, CU, CZ, DE, DK, DM, DO, DZ, EC, EE, EG, ES, FI, GB, GD, GE, GH, GM, GT, HN, HR, HU, ID, IL, IN, IS, JP, KE, KG, KM, KN, KP, KR, KZ, LA, LC, LK, LR, LS, LT, LU, LY, MA, MD, ME, MG, MK, MN, MW, MX, MY, MZ, NA, NG, NI, NO, NZ, OM, PE, PG, PH, PL, PT, RO, RS, RU, SC, SD, SE, SG, SK, SL, SM, ST, SV, SY, TH, TJ, TM, TN, TR, TT, TZ, UA, UG, US, UZ, VC, VN, ZA, ZM, ZW.
- (84) **Designated States (unless otherwise indicated, for every kind of regional protection available):** ARIPO (BW, GH, GM, KE, LR, LS, MW, MZ, NA, SD, SL, SZ, TZ, UG, ZM, ZW), Eurasian (AM, AZ, BY, KG, KZ, MD, RU, TJ, TM), European (AL, AT, BE, BG, CH, CY, CZ, DE, DK, EE, ES, FI, FR, GB, GR, HR, HU, IE, IS, IT, LT, LU, LV, MC, MK, MT, NL, NO, PL, PT, RO, RS, SE, SI, SK, SM, TR), OAPI (BF, BJ, CF, CG, CI, CM, GA, GN, GQ, GW, ML, MR, NE, SN, TD, TG).

**Published:**

— without international search report and to be republished upon receipt of that report (Rule 48.2(g))

(54) **Title:** A SECURING SYSTEM

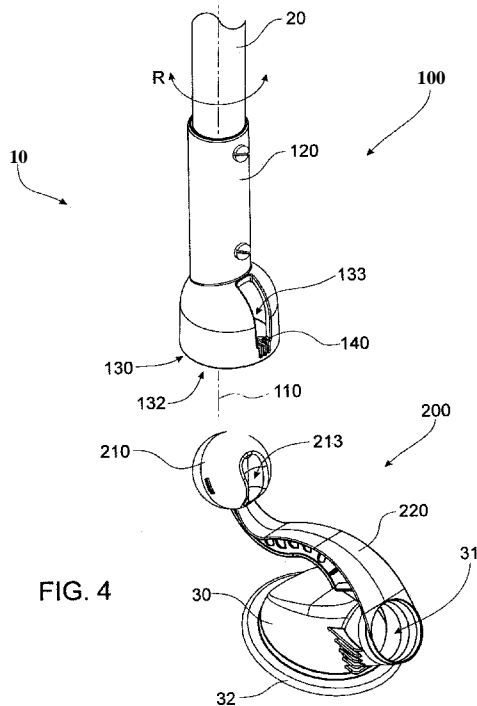

FIG. 4

(57) **Abstract:** A securing system (10) releasably secures a pole (20) to an automated pool cleaner (30) to direct and steer the pool cleaner (30). The securing system (10) comprises a pole attachment (100) and a coupling (200). The pole attachment (100) is fixed to the pole (20) and the coupling (200) is fixed to the pool cleaner (30). The pole attachment (100) includes a lock formation (140). Rotation of the lock formation (140) with respect to the coupling (200) causes the lock formation (140) to move between a locked position where the lock formation (140) is locked to the coupling (200) and an un-locked position wherein the pole (20) is releasable from the coupling (200).





- 2 -

The attachment means of Zell comprises two mating members with one being a fastener attached to the end of the vacuum pole. In order to effectively manoeuvre the pool cleaner from the side of the pool, a joint must be provided between the pool cleaner and the vacuum pole. Zell teaches a universal ball joint between the fastener and the vacuum pole. Some of the attachment means include bayonet type or screw-type connections where torque must be applied to the fastener to connect and disconnect the connections. One of the drawbacks of the invention of Zell is that it does not provide for transmission of torque from the vacuum pole to the fastener due to the universal ball joint being located between the fastener and the vacuum pole. Connection and disconnection of the vacuum pole and the pool cleaner may thus have to be performed above surface by turning the fastener by hand. What is required is a securing system for releasably locking a pole to an automated pool cleaner, wherein the securing system is easily operated from above surface.

#### OBJECT OF THE INVENTION

It is an object of the invention to overcome or at least alleviate one or more of the above problems and/or provide the consumer with a useful or commercial choice.

#### DISCLOSURE OF THE INVENTION

In a first form, although it need not be the only or indeed the broadest form, the invention resides in a securing system for releasably locking a pole to an automated pool cleaner, the securing system including:

- 3 -

a lock formation able to be rigidly coupled to the pole; and  
a coupling able to be fixed to the pool cleaner,  
wherein displacement by rotation of the lock formation with respect  
to the coupling causes the lock formation to move between a locked  
5 position where the lock formation is locked to the coupling and an un-  
locked position wherein the pole is releasable from the coupling.

The securing system preferably further comprises a pole  
attachment including:

the lock formation; and  
10 a mount formation for mounting the pole attachment to the pole, the  
lock formation rigidly coupled to the mount formation.

The coupling preferably includes a mating formation, wherein the  
lock formation and the mating formation are receivable within one another  
when aligned in the un-locked position of the lock formation.

15 The securing system preferably includes a ball of a ball-and-socket  
joint, and a socket of the ball-and-socket joint, the pole attachment  
including one of the ball and socket and the coupling including the other of  
the ball and socket.

The pole attachment preferably includes the socket having the lock  
20 formation projecting into a socket cavity of the socket.

The coupling preferably includes the ball having the mating  
formation.

The mating formation is preferably in the form of a groove or  
channel along the surface of the ball.

- 4 -

In another form, the invention resides in a lock formation of a securing system for releasably locking a pole to an automated pool cleaner, the lock formation able to be rigidly coupled to the pole, wherein displacement by rotation of the lock formation with respect to a coupling of  
5 the securing system causes the lock formation to move between a locked position where the lock formation is locked to the coupling and an unlocked position wherein the pole is releasable from the coupling.

The lock formation is preferably the same as the lock formation defined and described for the securing system in accordance with the first  
10 form of the invention.

In yet another form, the invention resides in a coupling of a securing system for releasably locking a pole to an automated pool cleaner, the coupling preferably including a ball of a ball-and-socket joint and a mating formation for receiving a lock formation fixed in the socket of  
15 the ball-and-socket joint.

The coupling is preferably the same as the coupling defined and described for the securing system in accordance with the first form of the invention

In another form, the invention resides in a method of securing a  
20 pole to an automated pool cleaner, the method including:

manipulating the pole so that a lock formation rigidly coupled to the pole is adjacent a coupling fixed to the pool cleaner;

aligning the lock formation of the pole attachment with a mating formation of the coupling;

- 5 -

introducing the lock formation into the mating formation; and  
rotating the pole to move the lock formation to a locked position  
with respect to the coupling.

The invention extends to an automated pool cleaner including the  
5 coupling as defined and described hereinabove. The invention extends  
also to a pole including the lock formation as defined and described  
hereinabove.

#### BRIEF DESCRIPTION OF THE DRAWINGS

To assist in understanding the invention and to enable a person  
10 skilled in the art to put the invention into practical effect, preferred  
embodiments of the invention will be described by way of example only  
with reference to the accompanying drawings, wherein:

FIG. 1 is a side view of a securing system in accordance with one  
embodiment of the invention, the securing system comprising a pole  
15 attachment fixed to a pole and a coupling fixed to a suction pool cleaner;

FIG. 2 is a perspective view of the pole attachment of FIG. 1;

FIG. 3 is a perspective view of the coupling and suction pool  
cleaner of FIG. 1;

FIG. 4 is a perspective view of the securing system of FIG 1 with  
20 the pole attachment spaced from the coupling;

FIG. 5 is a perspective view of the securing system of FIG 1 having  
a lock formation of the pole attachment in an un-locked position relative to  
the coupling;

FIG. 6 is a perspective view of the securing system of FIG 1

- 6 -

wherein the pole attachment is locked to the coupling with the lock formation of the pole attachment in a locked position;

FIG. 7 is a perspective view of another embodiment of an automated pool cleaner including a coupling in accordance with the invention;

FIG. 8 is a perspective view of yet another embodiment of an automated pool cleaner including a coupling in accordance with the invention;

FIG. 9 is a perspective view of a coupling in accordance with one embodiment of the invention releasably mounted to an automated pool cleaner; and

FIG. 10 is a perspective view of another embodiment of a coupling releasably mounted to a different type of automated pool cleaner.

## 15                    DETAILED DESCRIPTION OF THE INVENTION

In this patent specification, adjectives such as first and second, left and right, top and bottom, etc., are used solely to define one element or method step from another element or method step without necessarily requiring a specific relative position or sequence that is described by the adjectives. Words such as "comprises" or "includes" are not used to define an exclusive set of elements or method steps. Rather, such words merely define a minimum set of elements or method steps included in a particular embodiment of the present invention. In the drawings, like reference numerals refer to like parts.

- 7 -

Referring to FIG. 1, a securing system 10 in accordance with one embodiment of the invention comprises a pole attachment 100 and a coupling 200. The pole attachment 100 is fixed to a pole 20 and the coupling 200 is fixed to a suction-type automated pool cleaner 30. The  
5 securing system 10 releasably secures the pole 20 to the pool cleaner 30 as will be described in more detail hereinbelow.

FIG. 2 shows a perspective view of the pole attachment 100. The pole attachment 100 comprises: a mount formation in the form of a sleeve 120, a socket 130 and a lock formation 140. The pole attachment 100 has  
10 a first end 102 and a second end 104. The pole attachment 100 has rotational axis 110 about which the pole attachment 100 is rotatable. The rotational axis 110 extends from the first end 102 to the second end 104.

The sleeve 120 comprises a cylindrical wall 121 having a bore 122 in which an end of the pole 20 is received for mounting the pole  
15 attachment 100 to the pole 20. The wall 121 is concentric with the rotational axis 110. The sleeve 120 has four spaced holes 123 in the wall 121. The holes 123 are in pairs which are formed opposite each other in the wall 121. The pole 20 is fixed in the sleeve 120 by fasteners which  
20 extend through the holes 123 in the sleeve 120 and corresponding holes in the pole 20 as is well known in the art of vacuum pole accessories for swimming pools. FIG.1 shows fasteners in the form of bolts 40 and wing-nuts 42 fixing the pole 20 in the sleeve 120. Fasteners could also take the form of a quick release pin fitting, inserted inside the sleeve 120, to allow easy attachment and removal of a pole attachment 100 to the pole 20.

- 8 -

The pole 20 is a commonly available vacuum pole.

The socket 130 is integrally formed with the sleeve 120. The socket 130 is cup-shaped having a circumferential wall 131 defining a socket cavity. The socket 130 is eccentric relative to the longitudinal axis 110. A part 138 of the socket 130 thus bulges further away from the sleeve 120 and is spaced further from the rotational axis 110 than the remainder of the socket 130. A slot 133 is formed in the wall 131 of the socket 130. The slot 133 is formed in the part 138 of the socket 130. The slot 133 extends lengthwise parallel to the rotational axis 110. The slot 133 has opposite sides 134 and opposite ends 135, 136. The socket 130 has a mouth opening 132 at the second end 104 of the pole attachment 100, through which the socket cavity is accessed.

The lock formation 140 is in the form of a tab projecting inwardly into the socket cavity of the socket 130. The lock formation 140 projects from adjacent the end 136 of the slot 133. The lock formation 140 has an edge 141 which follows a semi circular profile extending between the sides 134 of the slot 133. The lock formation 140 is integrally formed with the wall 131 of the socket 130 and rigidly coupled to the sleeve 120. Rotation of the sleeve 120 about the rotational axis 110 thus moves the lock formation 140 about the rotational axis 110.

FIG. 3 shows a perspective view of the coupling 200 fixed to the pool cleaner 30. The coupling 200 comprises a ball 210 and an arm 220. The ball 210 is fixed to a distal end of the arm 220. A proximal end of the arm 220 is fixed to the pool cleaner 30. The arm 220 and pool cleaner 30

- 9 -

are integrally formed.

The ball 210 comprises two split halves 211 and 212. The two halves 211,212 are either screwed or clip-locked to each other and may be separated to reveal a hollow chamber in the ball 210. A mating  
5 formation in the form of a groove 213 is formed in a side of the ball 210, along a surface of the halve 212. The groove 213 has the same semi-circular profile, when viewed end-on, as the edge 141 of the lock formation 140. The groove 213 is located opposite the arm 220.

The pool cleaner 30 is of the suction-type having an opening 31 to  
10 which a suction hose (not shown) is connected. Water sucked through the opening 31 is used to drive locomotion of the pool cleaner and suck up debris. The pool cleaner has a foot 32 which is operatively in contact with the floor or walls of the pool.

FIG's 4 to 6 show the sequence, in use, of securing the pole 20 to  
15 the pool suction cleaner 30 using the securing system 10. The pool cleaner 30 roves the floor of a pool and the pole 20 is manipulated from the side of the pool. The pole attachment 100 is fixed to one end of the pole 20 by fasteners as discussed. The pole 20 is nestingly received in the sleeve 120 of the pole attachment 100. Rotation "R" of the pole 20 rotates  
20 the pole attachment 100 about its rotational axis 110.

FIG 4 shows the attachment 100 and the ball 210 spaced from each other. A person wanting to secure the pole 20 to the suction cleaner 30 manipulates the pole 20 so that the socket 130 of the pole attachment 100 is located adjacent the ball 210. The person rotates the pole 20 to

- 10 -

align the lock formation 140 with the groove 213. The slot 133 and arm 220 are visual aids for aligning the lock formation 140 with the groove 213. Aligning the slot 133 with the arm 220 aligns the lock formation 140 with the groove 213. The pole attachment 100 is then brought down on the

5 ball 210 in a spearing motion so that the ball 210 is received in the mouth opening 132 of the socket 130. The spearing motion is in a direction along the rotational axis 110. If the lock formation 140 and the groove 213 are aligned then the lock formation 140 will pass through the groove 213 and the ball 210 fully received in the socket cavity of the socket 130 (as

10 depicted in FIG. 5). If the lock formation 140 and the groove 213 are out of alignment then the lock formation 140 will press against the ball 210 and prevent the ball 210 from being fully received in the socket cavity of the socket 130. The pole 20 has to be rotated, while keeping downward pressure on the pole attachment 100, until the lock formation 140 and the

15 groove 213 are aligned and the lock formation 140 will then pass through the groove 213. Torque applied to the pole 20 when rotating the pole 20 is transferred to the lock formation 140 so that the lock formation 140 moves about the ball 210 until it aligns with the groove 213.

FIG. 5 shows the lock formation 140 in an un-locked position where

20 the lock formation 140 has passed through the groove 213, with the ball 210 received in the socket cavity of the socket 130. The socket 130 and the ball 210 together form a ball-and-socket joint 300 between the pole 20 and the pool cleaner 30. The pole 20 is articulately connected to the pool cleaner 30 via the ball-and-socket joint 300. FIG. 5 shows the lock

- 11 -

formation 140 still in alignment with the groove 213 such that the pole attachment 100 can be disengaged from the ball 210 by pulling back on the pole 20 and so breaking the ball-and-socket joint 300 apart. The lock formation 140 is moved from the un-locked position to a locked position by  
5 rotation of the pole 20. Rotation of the pole 20 rotates the lock formation 140 in an orbital fashion about the ball 210. In the locked position of the lock formation 140, the ball 210 is captured in the socket 130.

The locked position of the lock formation is shown in FIG. 6. Movement of the lock formation 140 from its un-locked position (depicted  
10 in FIG. 5) to its locked position (depicted in FIG. 6) is achieved by rotation of the pole 20. More specifically, FIG. 6 shows the lock formation 140 in a position wherein the lock formation 140 has rotated 90degrees clockwise about the rotational axis 110, relative to its un-locked position. In the locked position, the lock formation 140 is captured below the ball 210.  
15 Pulling back on the pole 20 makes the lock formation 140 engage the ball 210, without the lock formation 140 being able to pass over the ball 210. The attachment 100 is thus secured to the coupling 200 and the ball-and-socket joint 300 can not be broken apart. The ball-and-socket joint 300 provides articulation of the pole 20 relative to the pool cleaner when the  
20 lock formation 140 is in the locked position. The ball-and-socket joint 300 will not break apart when pulling back on the pole 20 whilst the lock formation 140 is in the locked position. The pool cleaner 30 can thus be lifted from the floor of the pool by pulling back on the pole 20 when the lock formation 140 is in the locked position. This is beneficial to lift and

- 12 -

move the pool cleaner 30, or to remove the pool cleaner 30 from the pool.

In order to release the ball 210 from the socket 130, the pole 20 is rotated so that the lock formation 140 is back at its un-locked position (depicted in FIG. 5) and the pole 20 is then translated upwardly away from  
5 the pool cleaner so that the pole attachment 100 is spaced from the ball 210 (depicted in FIG. 4).

The securing system 10 provides for easy locking and un-locking of the pole 20 to the pool cleaner 30 by manipulation of the pole 20. Having the socket 130 fixed at the attachment 100 and the ball 210 fixed at the  
10 coupling 200 allows for rotation of the socket 130 relative to the ball 210 by rotation of the pole 20. Specifically, the attachment 100 rigidly couples the lock formation 140 to the pole 20, enabling the lock formation 140 to rotate with respect to the ball 210 to thereby move the lock formation between the locked position and the un-locked position by rotation of the  
15 pole 20. The ball-and-socket joint 300 allows articulation of the pole 20 where it connects to the pool cleaner 30, which is necessary to redirect and steer the pool cleaner 30.

The ball 210 has a dual function as the ball for the ball-and-socket joint 300 and also as a float. Automatic pool cleaners are usually fitted  
20 with a float to stop them from toppling when they are not in operation. The ball 210 acts as such a float for the pool cleaner 30. The two halves 211,212 of the ball 210 are separable to reveal a chamber as discussed. The Applicant envisages that weights may be placed in the chamber to change the float characteristics of the ball 210.

- 13 -

The above description of pool cleaner 30 is in respect of a suction-type automated pool cleaner. FIG's 7 and 8 show perspective views of other embodiments of automated pool cleaners including the ball 210 as described for the pool cleaner 30.

5           FIG. 7 shows a pressure-type pool cleaner 300 including the ball 210 mounted at the distal end of an arm 302. Pressure-type pool cleaners connect to the return side of the pool filter system. The pool cleaner 300 includes a fine mesh bag 304 in which dirt and debris is deposited.

10           FIG. 8 shows a robotic-type pool cleaner 400. The pool cleaner 400 includes an arm 402 and the ball 210. The ball 210 is mounted at a distal end of the arm 402.

The ball 210 may be mounted to the pool cleaners 300, 400 as shown in FIG's 9 and 10.

15           FIG. 9 shows a coupling 500 which is releasably mounted to a pool cleaner 600. The coupling 500 comprises a releasable mounting member in the form of a screw clamp 502, the ball 210 described above, and an arm 504 extending between the screw clamp 502 and the ball 210. The ball 210 is fixed to a distal end of the arm 504. A proximal end of the arm 504 is fixed to the screw clamp 502. The screw clamp 502 may be fixed  
20           to any annular region of the pool cleaner 600, including being fixed around a suction or return pipe.

FIG. 10 shows a coupling 700 which is releasably mounted to a pool cleaner 800. The coupling 700 comprises a releasable mounting member in the form of a clamp 702, the ball 210 described above, and an arm 704

- 14 -

extending between the clamp 702 and the ball 210. The ball 210 is fixed to a distal end of the arm 704. A proximal end of the arm 704 is fixed to the clamp 702. The clamp 702 may be fixed to any annular region of the pool cleaner 700, including being fixed around a suction or return pipe.

- 5           Throughout the specification the aim has been to describe the invention without limiting the invention to any one embodiment or specific collection of features. Persons skilled in the relevant art may realize variations from the specific embodiments that will nonetheless fall within the scope of the invention.

- 15 -

CLAIMS

1. A securing system for releasably locking a pole to an automated pool cleaner, the securing system including:
  - a lock formation able to be rigidly coupled to the pole; and
  - a coupling able to be fixed to the pool cleaner,wherein displacement of the lock formation with respect to the coupling causes the lock formation to move between a locked position where the lock formation is locked to the coupling and an un-locked position wherein the pole is releasable from the coupling.
2. The securing system of claim 1, wherein the coupling includes a mating formation, and wherein the lock formation and the mating formation are receivable within one another when aligned in the un-locked position of the lock formation.
3. The securing system of claim 1 or claim 2, wherein the securing system includes a pole attachment comprising:
  - the lock formation; and
  - a mount formation for mounting the pole attachment to the pole, the lock formation rigidly coupled to the mount formation.
4. The securing system of claim 3, wherein the securing system includes a ball of a ball-and-socket joint, and a socket of the ball-and-socket joint, the

- 16 -

pole attachment including one of the ball and socket and the coupling including the other of the ball and socket.

5. The securing system of claim 4, wherein the pole attachment includes the socket having the lock formation projecting into a socket cavity of the socket and the coupling includes the ball having the mating formation.
6. The securing system of claim 4 or claim 5, wherein the mating formation is in the form of a groove or channel along the surface of the ball.
7. A pole attachment of a securing system for releasably locking a pole to an automated pool cleaner, the pole attachment comprising:
  - a lock formation, wherein displacement of the lock formation with respect to a coupling of the securing system causes the lock formation to move between a locked position where the lock formation is locked to the coupling and an un-locked position wherein the pole is releasable from the coupling; and
  - a mount formation for mounting the pole attachment to the pole, the lock formation rigidly coupled to the mount formation.
8. The pole attachment of claim 7, including a socket having the lock formation projecting into a socket cavity of the socket.

- 17 -

9. A coupling of a securing system for releasably locking a pole to an automated pool cleaner, the coupling including a ball of a ball-and-socket joint and a mating formation for receiving a lock formation fixed in the socket of the ball-and-socket joint.
10. The coupling of claim 9, wherein the mating formation is in the form of a groove or channel along the surface of the ball.
11. A method of securing a pole to an automated pool cleaner, the method including:
  - manipulating the pole so that a lock formation rigidly coupled to the pole is adjacent a coupling fixed to the pool cleaner;
  - aligning the lock formation of the pole attachment with a mating formation of the coupling by rotating the pole;
  - introducing the lock formation into the mating formation; and
  - rotating the pole to move the lock formation to a locked position with respect to the coupling.
12. An automated pool cleaner including a coupling, the coupling including a ball of a ball-and-socket joint and a mating formation for receiving a lock formation fixed in the socket of the ball-and-socket joint.
13. The automated pool cleaner of claim 12, wherein the mating formation is in the form of a groove or channel along the surface of the ball.

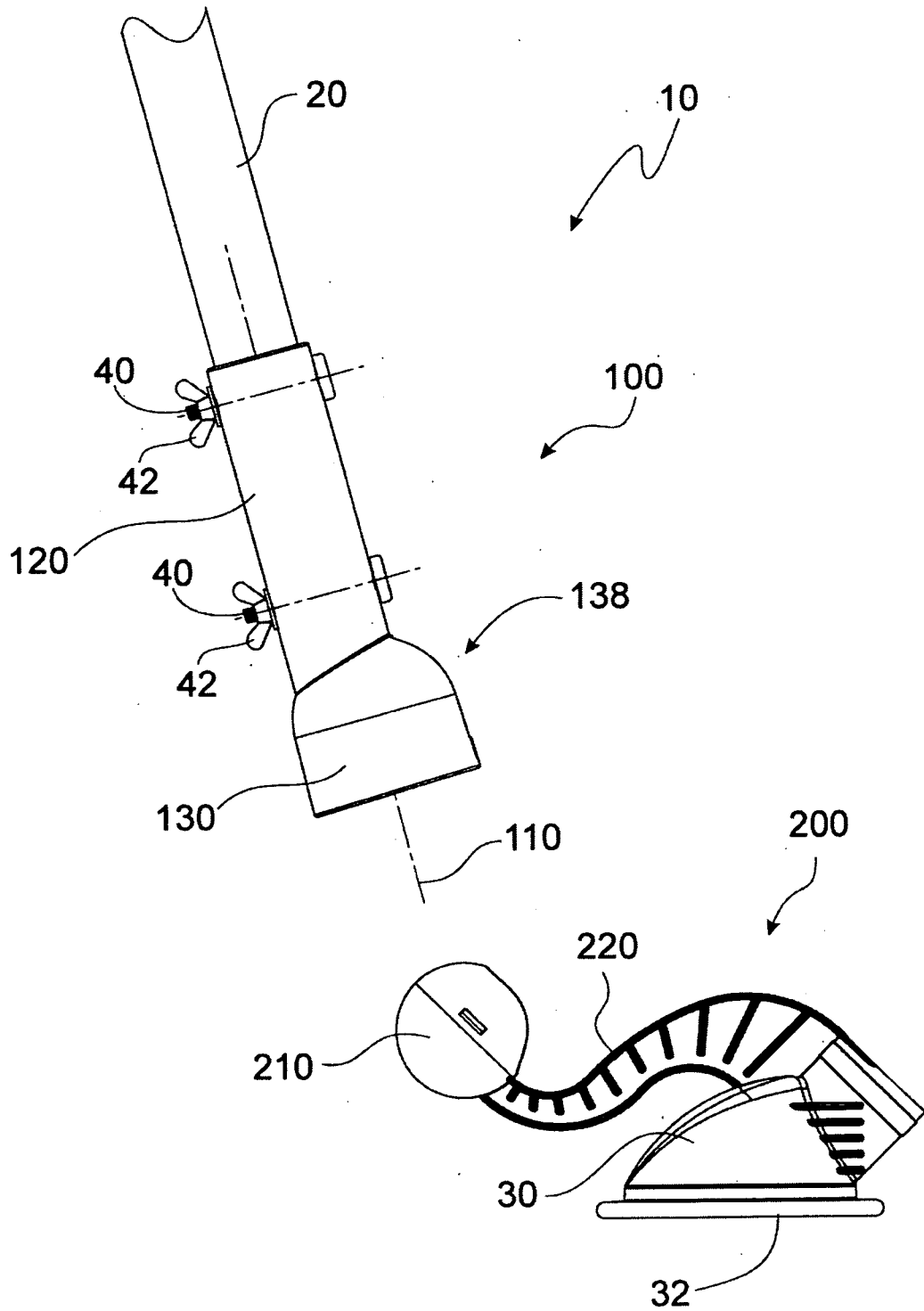

FIG. 1

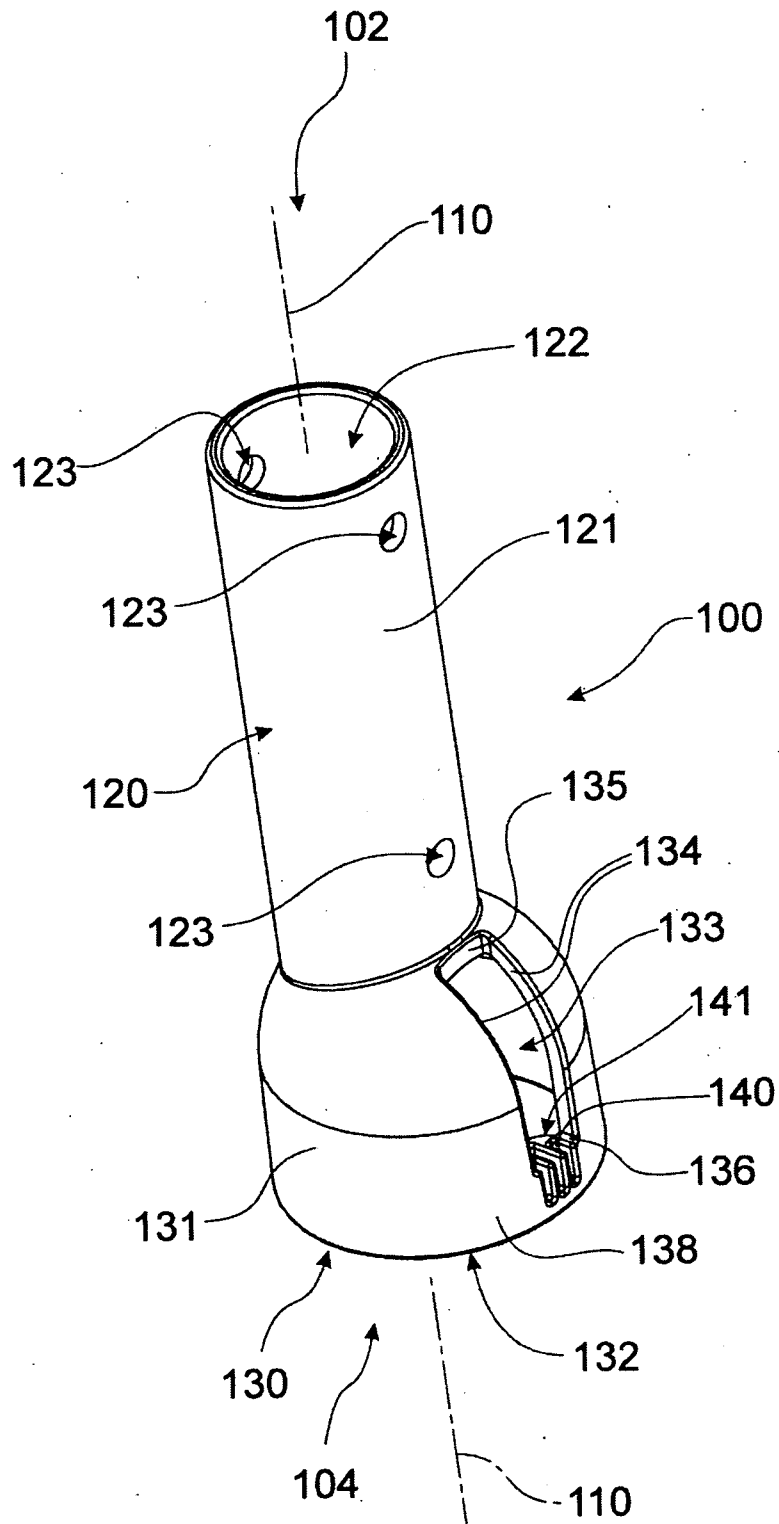

FIG. 2

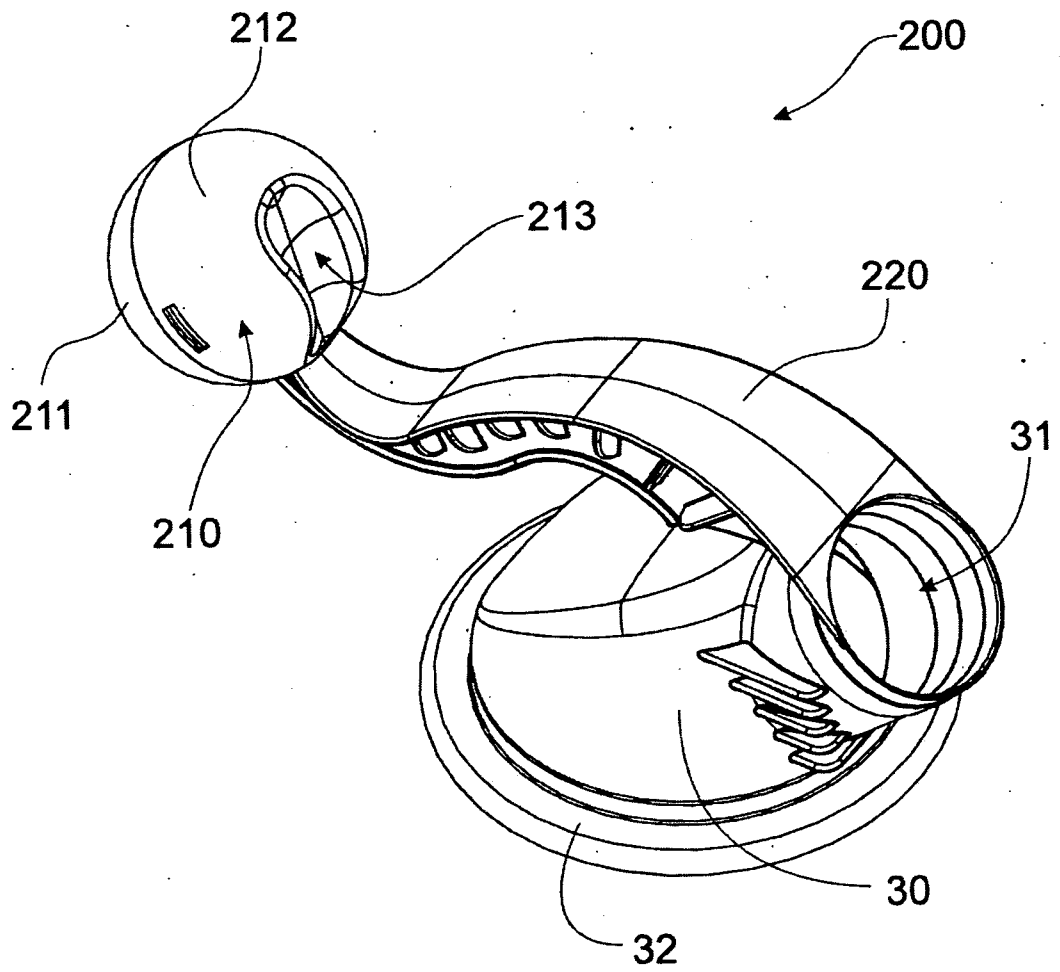

FIG. 3

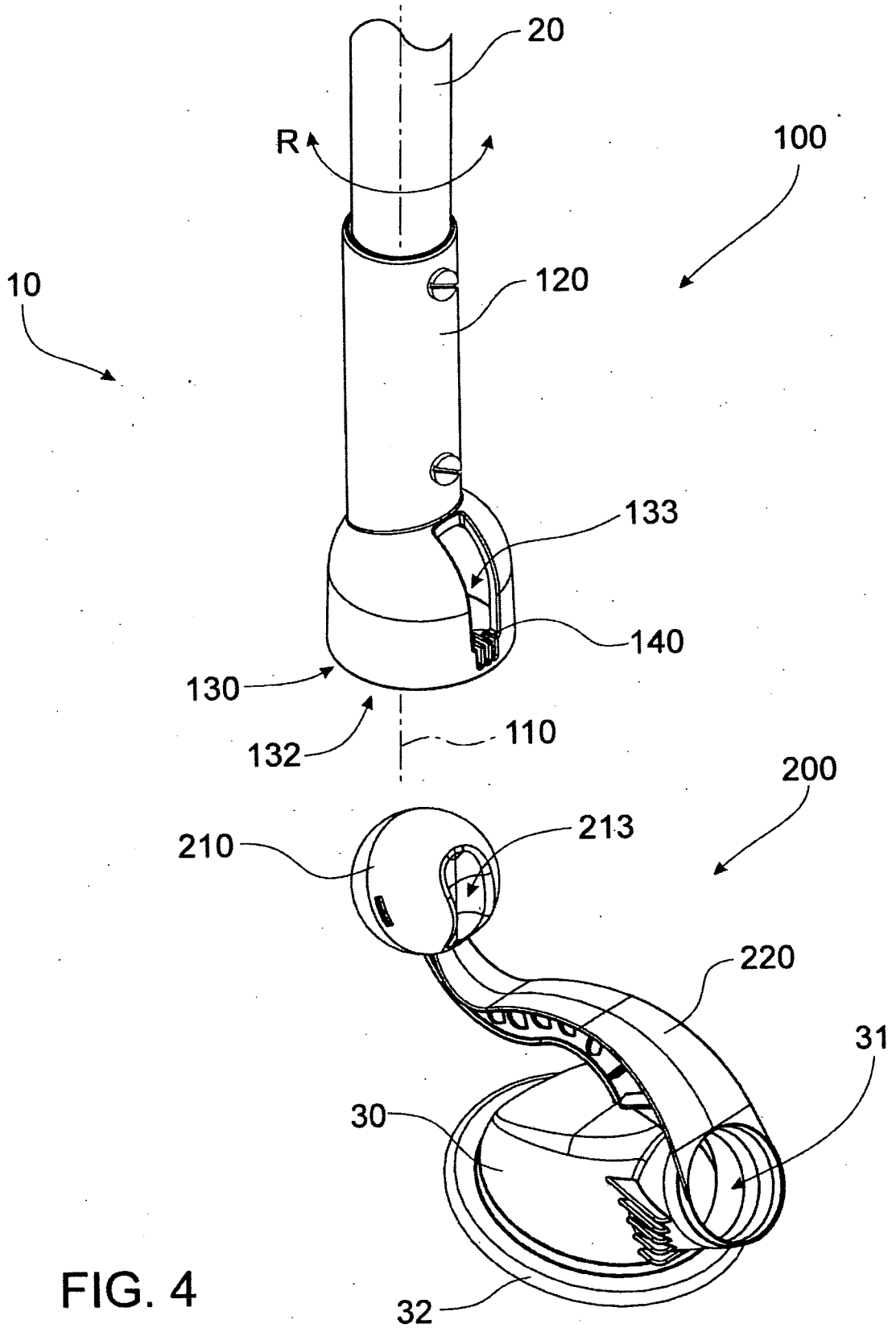

FIG. 4

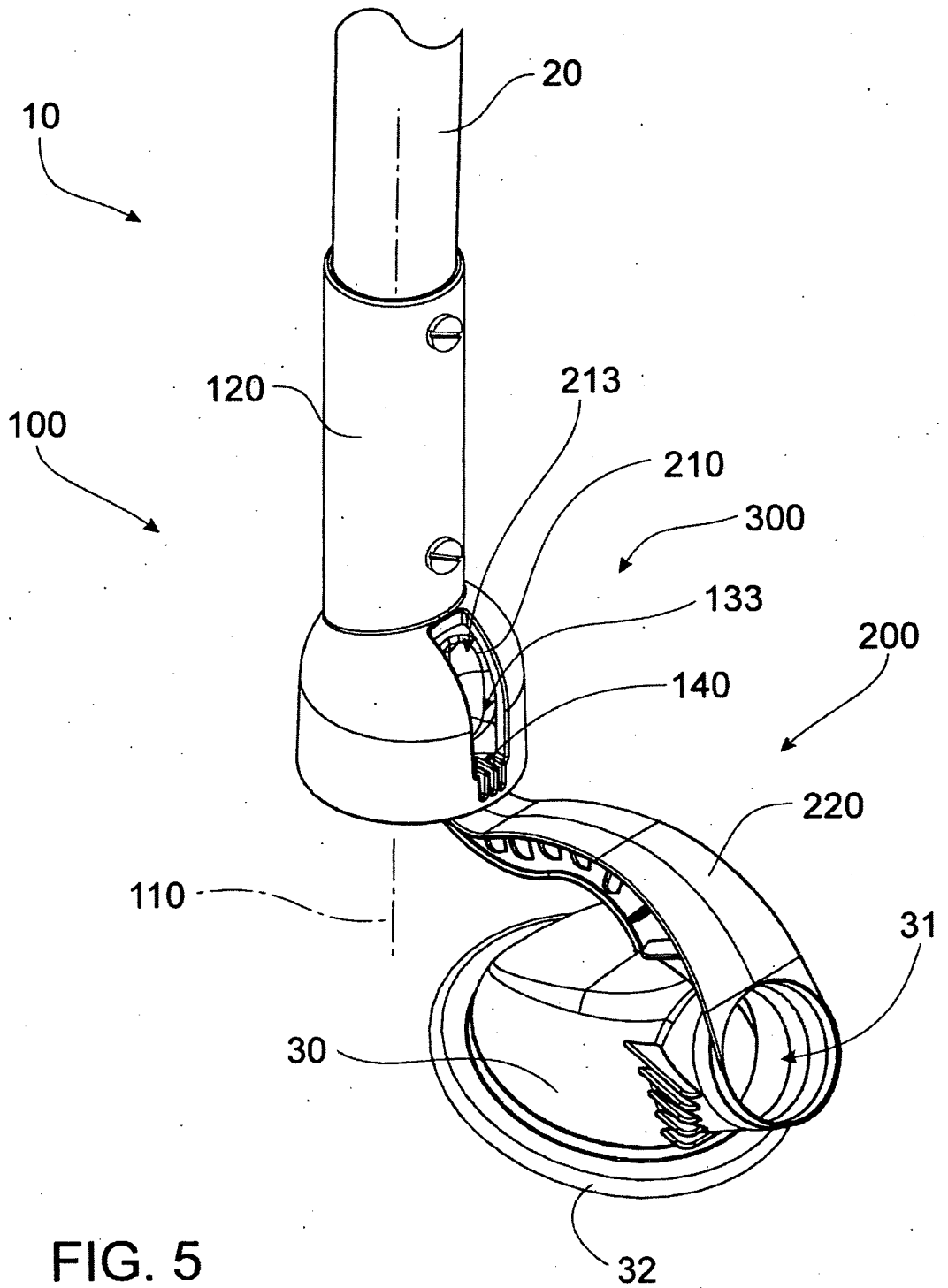

FIG. 5

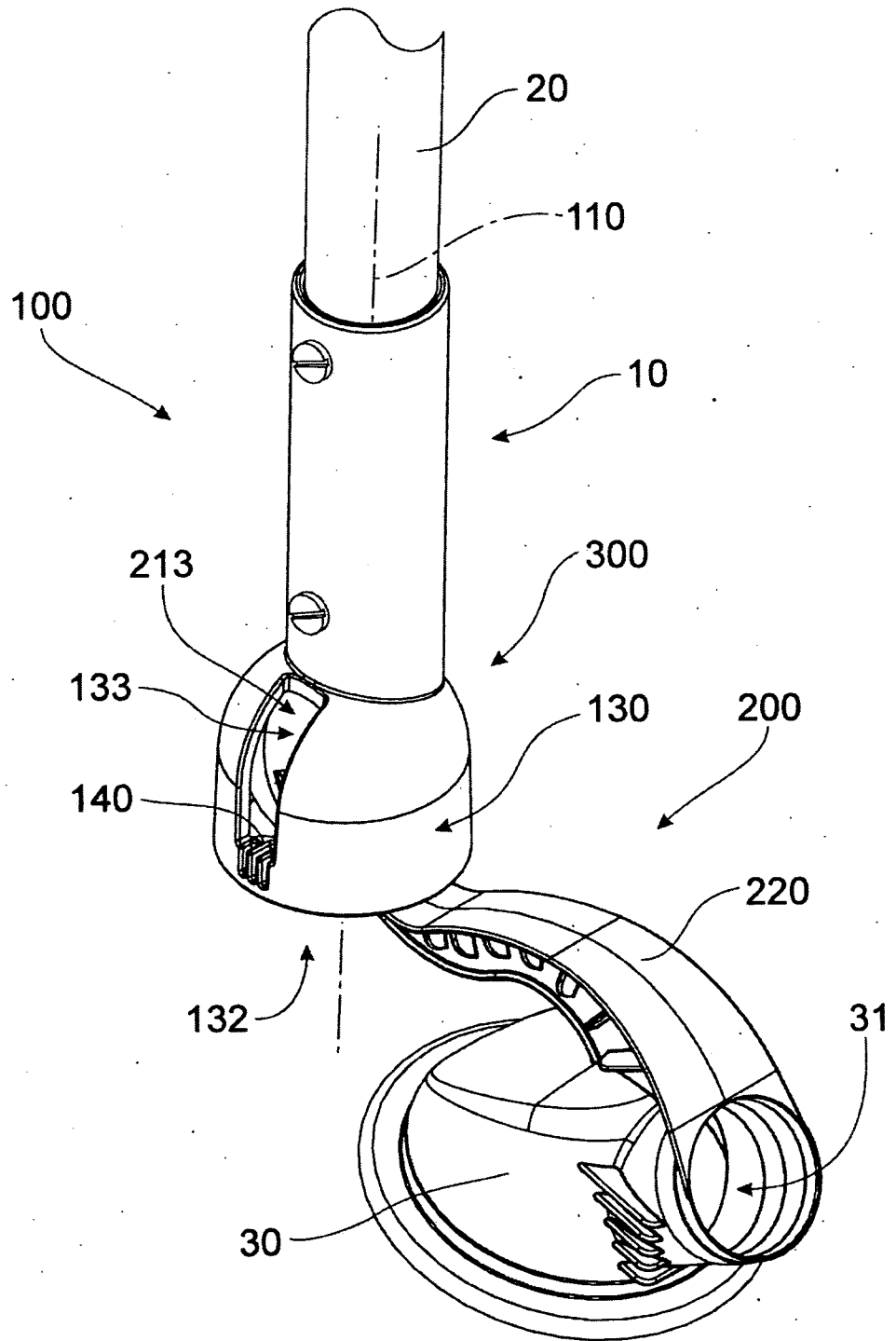

FIG. 6

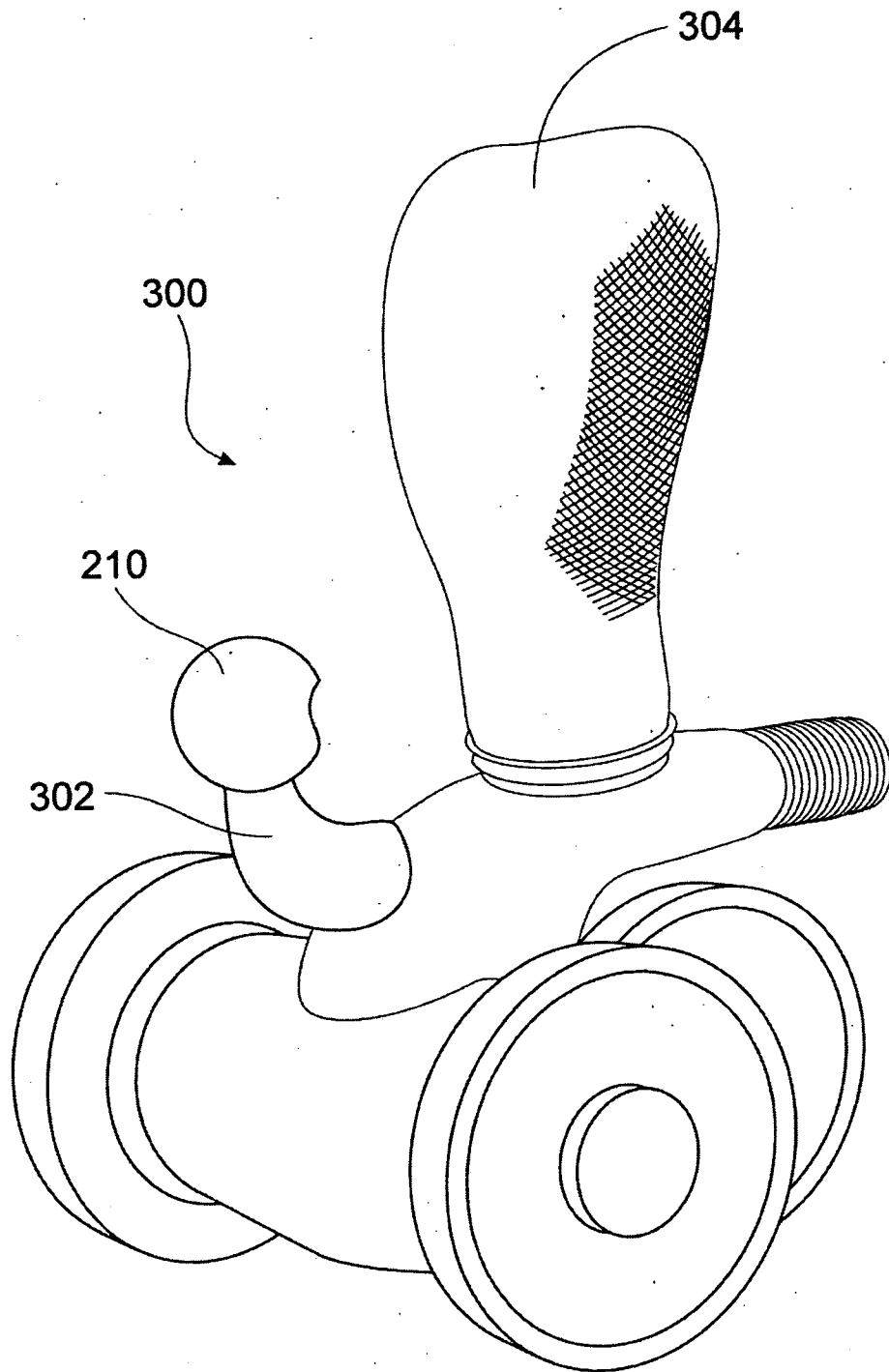

FIG. 7

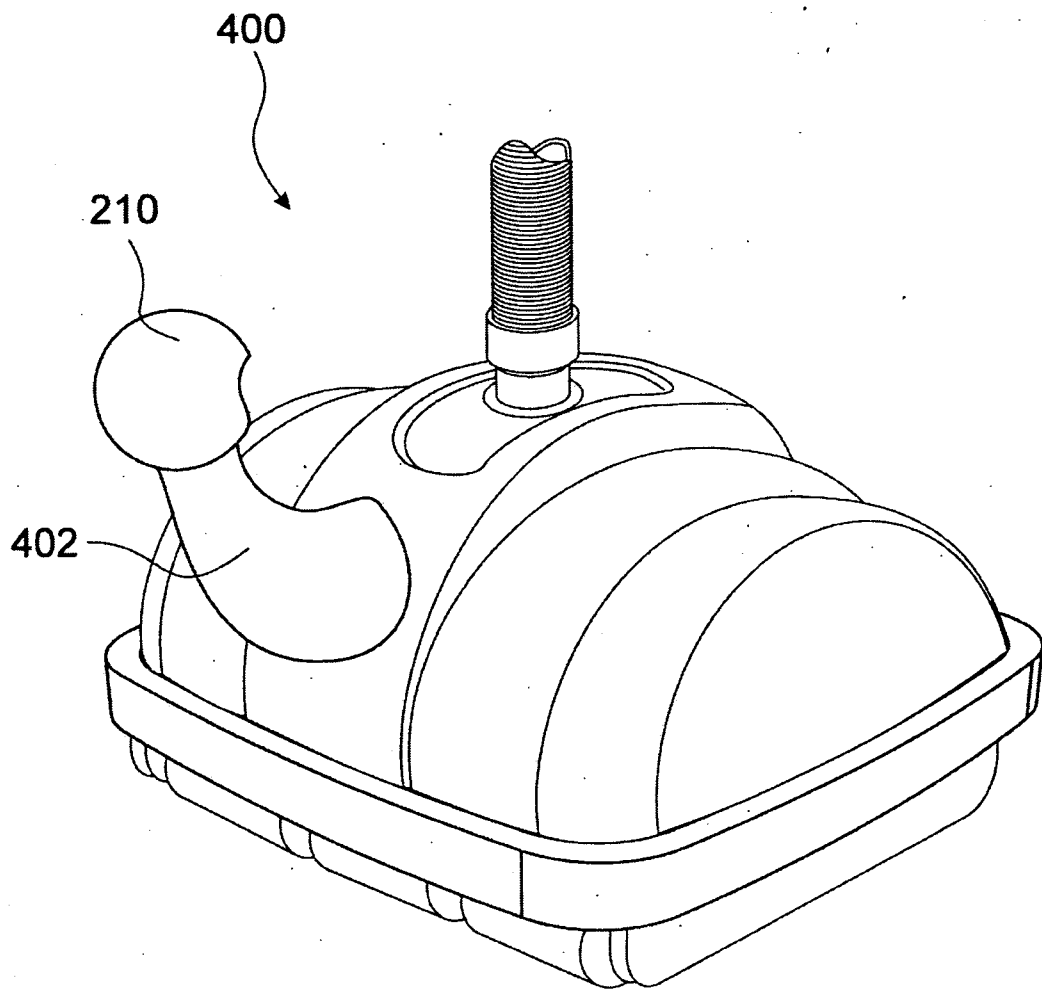

FIG. 8

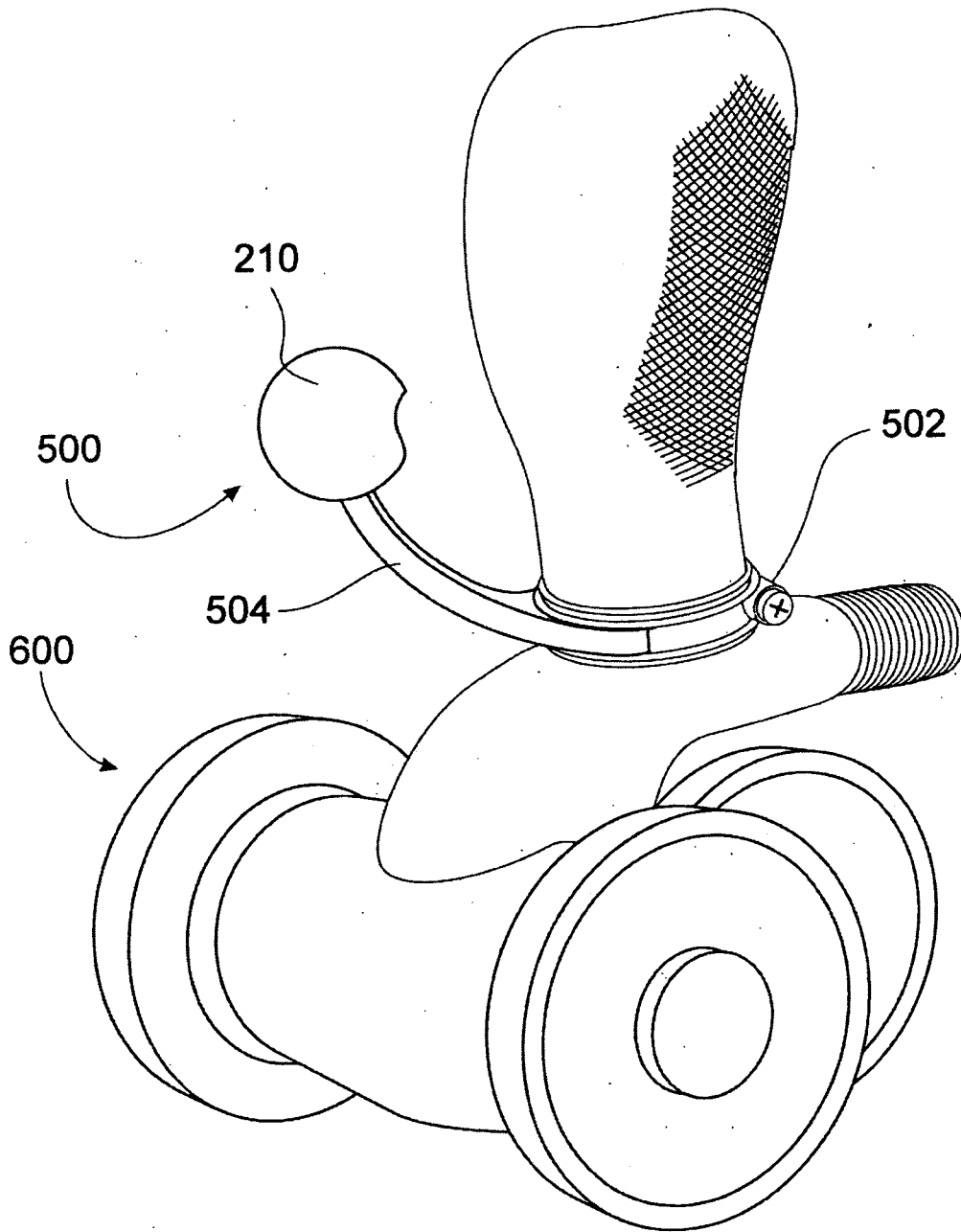

FIG. 9

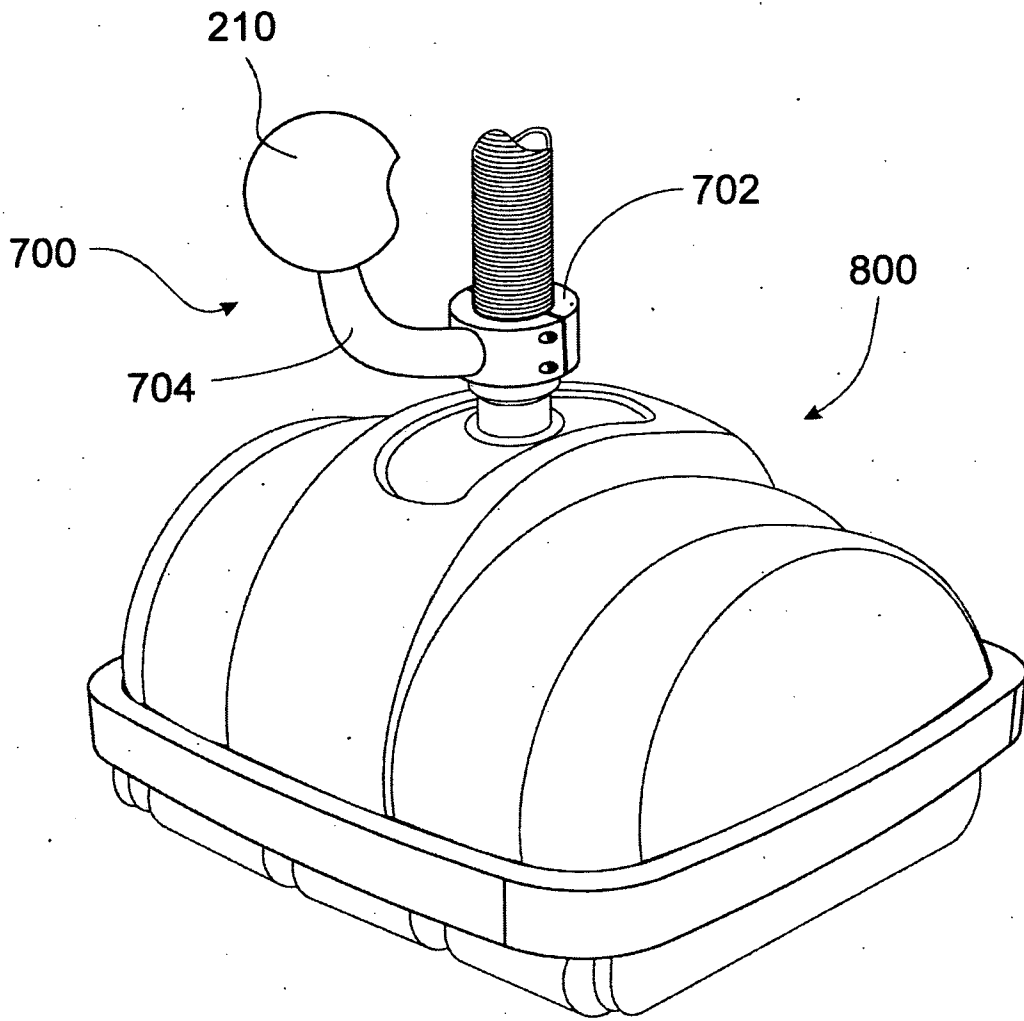

FIG. 10